

GROSS LOAD CAPACITY WHEN USED AS A WEIGHT CARRYING HITCH: 1,000 LBS. TRAILER WEIGHT & 100 LBS. TONGUE WEIGHT.

DO NOT EXCEED VEHICLE MANUFACTURER'S RECOMMENDED TOWING CAPACITY.

WARNING: ALL NON-TRAILER LOADS APPLIED TO THIS PRODUCT MUST BE SUPPORTED BY 18050 STABILIZING STRAPS.

** FAILURE TO PROPERLY SUPPORT NON-TRAILER LOADS WILL VOID PRODUCT WARRANTY**

Parts List			
ITEM	QTY	PART NUMBER	DESCRIPTION
1	2	M10 - 1.25 x 30	HEX BOLT
2	2	7/16	HELICAL LOCK WASHER
3	3	3/8 - 16 x 1 1/4	HEX BOLT
4	3	3/8"	FENDER WASHER
5	3	3/8"	LOCK WASHER
6	3	3/8 - 16	HEX NUT

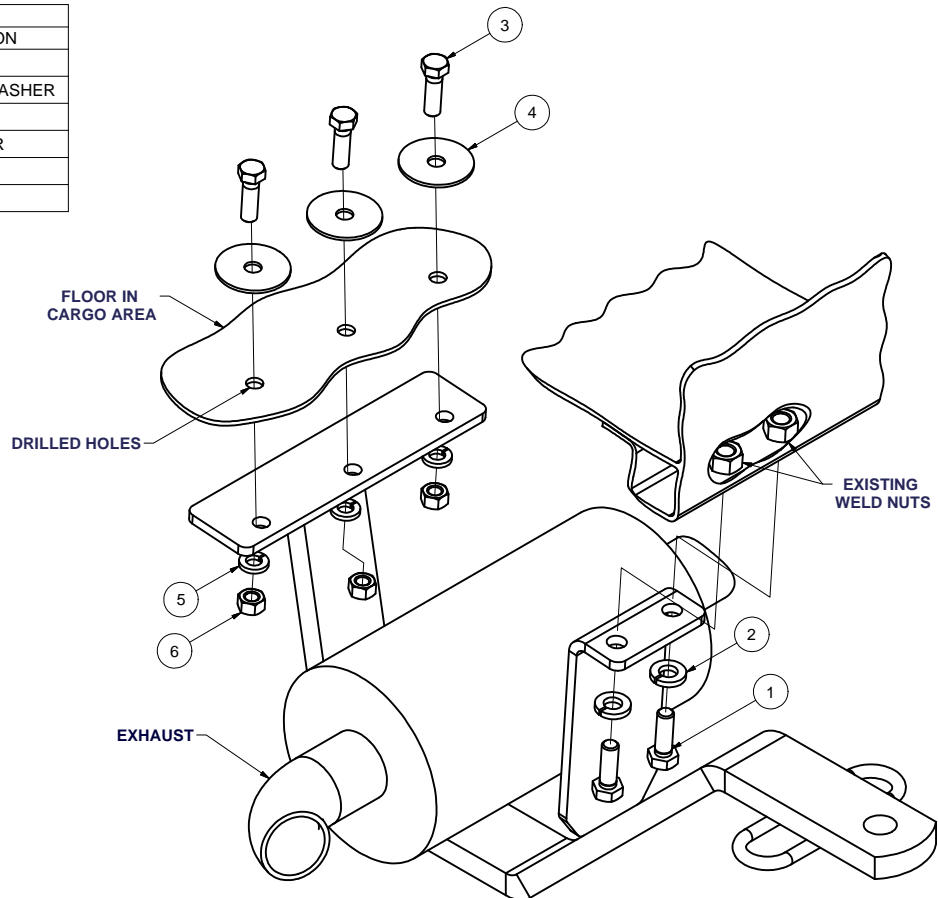

HITCH WEIGHT: 14 LBS.

INSTALL TIME

PROFESSIONAL: 30 MINUTES

NOVICE (DIY): 60 MINUTES

INSTALL NOTES:

- REMOVE HEAT SHIELD
- REMOVE TOW LOOP
- CLEAR CARGO AREA
- DRILLING REQUIRED
- SILICONE SEAL HARDWARE

INSTALLATION STEPS

1. Under the rear of the vehicle, remove the fasteners from the heat shield over the muffler. Shield needs to be removed only enough to reach the (3) fasteners holding the tow loop at the rear center of the vehicle. Remove the tow loop and return it to the vehicle owner. Rear hitch plate will mount to (2) existing weldnuts where tow loop was attached.
2. Remove any carpet and material inside the cargo area of the vehicle. Fasten the hitch temporarily in place using existing weld nuts as shown. Using the hitch as a template, mark the underside of the floor for (3) holes. Centerpunch and drill up through the floor for 3/8" diameter fasteners.
3. Install remaining fasteners provided with the hitch. Be certain to use the fender washers inside the vehicle, opposite the hitch.
4. Torque all 10mm fasteners to 41 lb-ft, and all 3/8" fasteners to 30 lb-ft.
5. Use silicone sealant to seal hardware installed through cargo area floor.
6. Reinstall carpet and other contents removed in Step 2.

PERIODICALLY CHECK THIS RECEIVER HITCH TO ENSURE THAT ALL FASTENERS ARE TIGHT AND THAT ALL STRUCTURAL COMPONENTS ARE SOUND.

Curt Manufacturing Inc., warrants this product to be free of defects in material and/or workmanship at the time of retail purchase by the original purchaser. If the product is found to be defective, Curt Manufacturing Inc., may repair or replace the product, at their option, when the product is returned, prepaid, with proof of purchase. Alteration to, misuse of, or improper installation of this product voids the warranty. Curt Manufacturing Inc.'s liability is limited to repair or replacement of products found to be defective, and specifically excludes liability for incidental or consequential loss or damage.