

INSTALLATION INSTRUCTIONS

WARNING: NEVER EXCEED YOUR VEHICLE MANUFACTURER'S RECOMMENDED TOWING CAPACITY

MULTI-FIT TRAILER HITCH

CLASS 3



PARTS LIST

Item#	Qty	Description
1	1	Fishwire, 1/2"
2	2	Hex bolt, 1/2" - 13 x 3 1/2"
3	8	Lock washer, 1/2"
4	8	Hex nut, 1/2" - 13
5	6	Hex bolt, 1/2" - 13 x 1 1/2"
6	6	Flat washer, 1/2"

WEIGHT RATINGS

Capacity when used as a weight carrying hitch
5,000 lbs. gross trailer weight

Note: Chevrolet / GMC Astrovan has a lesser weight rating.

Capacity when used as a weight carrying hitch
3,500 lbs. gross trailer weight

INSTALLATION NOTES

Hitch weight: 42 lbs.

Install time: 60 minutes

Drilling required

Fishwire fasteners

HOLE SELECTION DIAGRAMS

Measure center-to-center distance of frame rails. See the tables and figures below to determine which holes to use.

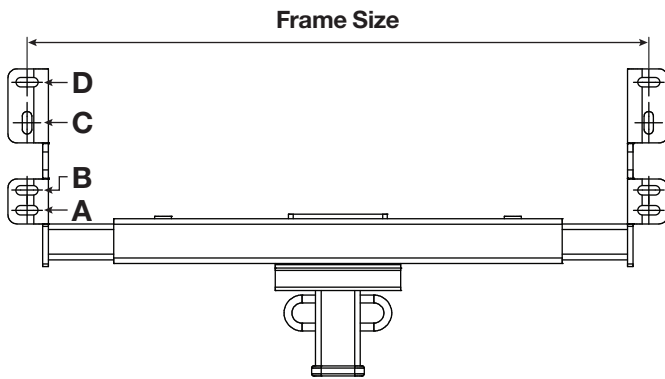

Vehicle Make / Model	Drill Frame Attachment Holes
Chevrolet / GMC	
Astro, extended chassis	Drill hole D Use existing holes B, C
Blazer	Drill hole D Use existing hole A
Blazer, full-size	Drill holes A, C, D
Jimmy, full-size	Drill holes A, C, D
Pickups, full-size, 8' bed, excluding step-side and 1 ton	Drill holes A, C, D
Pickups, full-size, excluding step-side and 1 ton	Drill holes A, C, D
S-10 pickup, short bed 4 x 4	Drill hole C Use existing hole B
S-10 pickup, long bed	Drill hole D Use existing hole B
S-10 pickup, crew cab	Drill hole C Use existing hole B
S-15 pickup, short bed 4 x 4	Drill hole C Use existing hole B
S-15 pickup, long bed	Drill hole D Use existing hole B
S-15 pickup, crew cab	Drill hole C Use existing hole B
Safari (spare tire may need relocating)	Drill holes B, C, D
Safari, extended cab	Drill hole D Use existing holes B,C
Silverado / Sierra 1500, classic body, 8' bed	Drill holes C, D Use existing hole A
Silverado / Sierra 2500HD / 3500, full-size, 8' bed, excluding step-side	Drill holes C, D Use existing hole A
Silverado / Sierra 2500LD, 8' bed	Drill holes C, D Use existing hole A
Suburban	Drill holes C, D Use existing hole A
Tahoe	Drill holes A, C, D
G-Series, full-size van	Drill holes A, C, D
Express / Savana, full-size van	Drill holes C, D Use existing hole A
Venture	Drill holes A, C, D
Yukon, Yukon XL	Drill holes A, C, D

Vehicle Make / Model	Drill Frame Attachment Holes
Chrysler	
Town & Country, excluding Stow-n-go	For years 90 - 95 Use existing holes A, D
Town & Country, excluding Stow-n-go	For years 96 -07 Use existing holes A, B, C
Dodge	
Caravan, excluding Stow-n-go	Drill holes A, D
Dakota	Drill holes B, C, D
Dakota, quad cab	Drill holes B, C, D
Pickups, full-size, excluding 1 ton	Drill holes A, C, D
Ramcharger	Drill holes A, B, D
Ford	
Aerostar, extended cab	Drill holes A, B, D
Bronco, full-size	Drill holes A, C, D
Bronco II	Drill holes A, D
Escape	Drill hole D Use existing holes A, B
F-150 pickups, step sides with 6' bed (spare tire may need relocating)	Drill holes A, C, D
F-150 pickups, 8' bed	Drill holes A, C, D
F-250 pickups, 6' bed	Drill holes A, C, D
F-250 / F-350 pickups, 8' bed, excluding 20" spare tire	Drill holes A, C, D
Pickups, 6' and 8' beds, excluding step sides and 1 ton	Use existing holes B, C, D
Ranger, excluding 98 - 06 flare side	Drill holes C, D Use existing hole A
Ranger, 8' bed only (spare tire needs relocating)	Drill holes C, D Use existing hole A
E-series vans, excluding 1 ton	Drill holes C, D Use existing holes A or B
Windstar	Use existing holes B, C
Isuzu	
Hombre, short bed 4 x 4	Drill hole C Use existing hole B
Jeep	
Cherokee XJ	Use existing holes A, B, D
Grand Cherokee	Use existing holes A, B, C
Liberty	Use existing holes A, C
Mazda	
Pickup, excluding 98 - 06 flare side	For years 90 - 93 Use existing holes B, C
Pickup, excluding 98 - 06 flare side	For years 94 - 09 Use existing holes B, C, D
Tribute	Use existing holes A, B, D
Nissan	
Pickup and Frontier with 56" bed	Use existing holes B, D
Pickup and Frontier with 75" bed	Use existing holes A, B, C
Plymouth	
Trail Duster	Use existing holes B, D
Voyager	Use existing holes A, D
Toyota	
Pickups, 8' bed, excluding T-100	Use existing holes A, C
Tundra	Use existing holes A, C

PARTS LIST

Item#	Qty	Description
1	1	Fishwire, 1/2"
2	2	Hex bolt, 1/2" - 13 x 3 1/2"
3	8	Lock washer, 1/2"
4	8	Hex nut, 1/2" - 13
5	6	Hex bolt, 1/2" - 13 x 1 1/2"
6	6	Flat washer, 1/2"

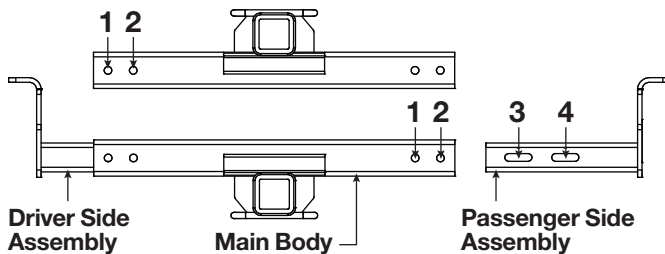
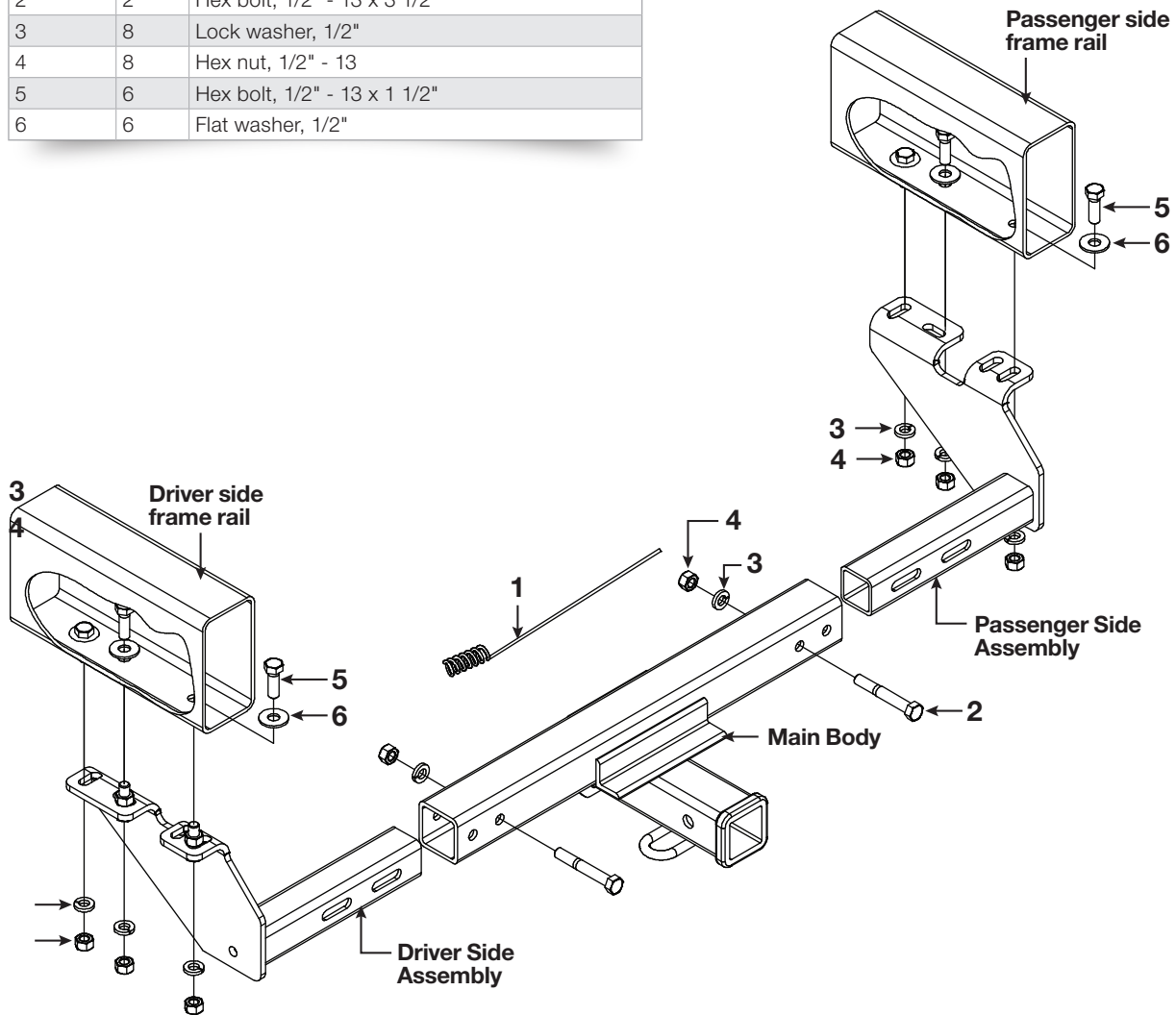

For Frame Size	Use Holes
31" to 33 1/3"	One and four
35"	Two and four
37 1/2"	One and three
39"	One and three
41"	Two and three

FISHWIRE TECHNIQUE

Insert coiled end of fishwire tool through hitch mounting hole in vehicle frame rail and out the access hole. Pass coiled end of fishwire through spacer and thread bolt into coil. Kink wire to keep spacer separate from bolt as shown. Pull fishwire, spacer and bolt through frame and out mounting hole. Use fishwire to guide hitch during mounting and prevent loss of bolt or spacer inside frame rail.

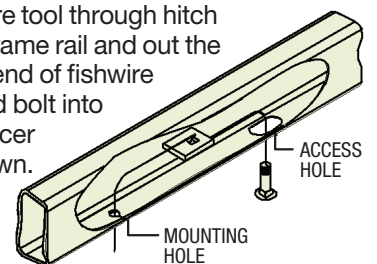

INSTALLATION

Step 1

Measure center-to-center distance of frame rails. See the table and figures below to determine which holes to use.

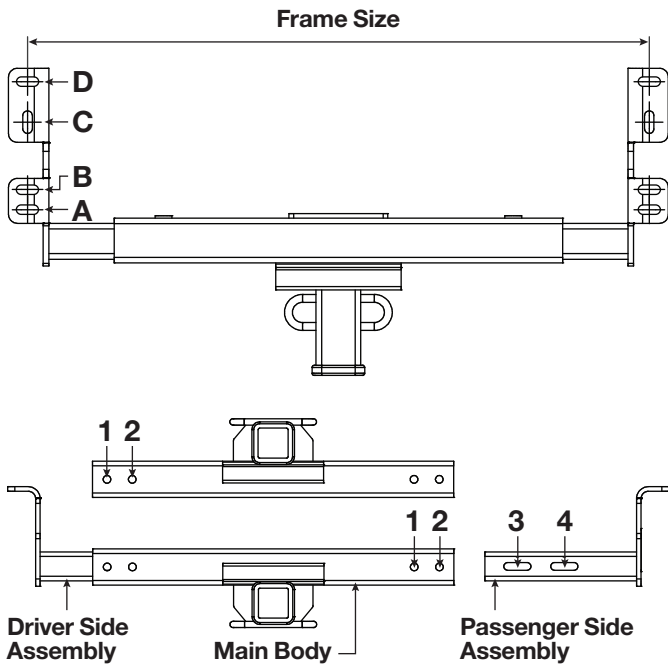

For Frame Size	Use Holes
31" to 33 1/3"	One and four
35"	Two and four
37 1/2"	One and three
39"	One and three
41"	Two and three

Step 2

Some vehicles may have one or two holes in the frame to help locate the hitch. Use the hole(s) in the frame and drill holes A, B, C or D as recommended on the vehicle application listing on page 2.

On vehicles without frame holes, hold the hitch up to the frame using C-clamps, then mark and drill holes in the frame.

On some vehicles (mostly Ford) the frame may have a rivet which interferes with the installation. Remove the rivet and use the hole to bolt the hitch to the frame if desired or bolt to the frame using holes A, C and D.

On Chevy and GMC full-size vans, remove and discard the bumper bracket before installing hitch.

On Chevy and GMC mini-vans, place driver and passenger side frame rails between bumper bracket and frame.

For 1993 - 1997 Chevy Astro van, see diagram in next column.

Note: Installation of some models may be easier if spare tire is removed during installation. On Ford trucks, the spare tire bracket must be removed or adjusted before installing hitch.

Side view of Chevy Astro van installation

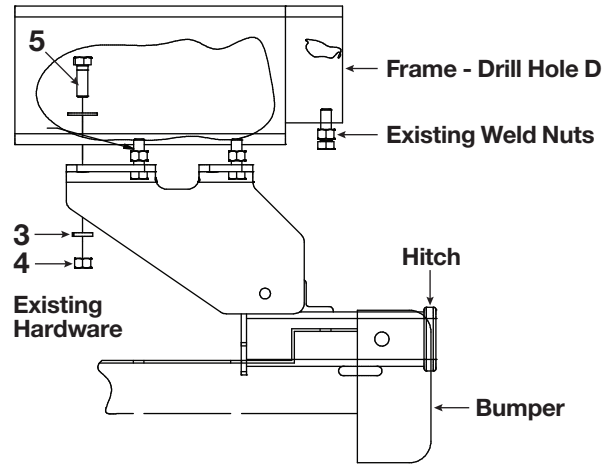

Step 3

Bolt the driver side plate to the frame using 1/2" x 1 1/2" bolts (#5), flat washers (#6), lock washers (#3) and 1/2" nuts (#4), tighten firmly.

Step 4

Slide the main body assembly over the driver side plate insert. Slide the passenger side insert into the main body.

Note: Main body assembly can be reversed for use on Ford vans.

Step 5

Align the holes in driver side plate insert with the holes in the main body assembly and secure with 1/2" x 3 1/2" bolts (#2), lock washers (#3) and 1/2" nuts (#4).

Step 6

Align the holes in the passenger side plate insert with the holes in the main body assembly and secure with 1/2" x 3 1/2" bolts (#2), lock washers (#3) and 1/2" nuts (#4).

Step 7

Hold hitch up to frame and bolt passenger side plate to frame using 1/2" x 1 1/2" bolts (#5), flat washers (#6), lock washers (#3) and 1/2" nuts (#4).

Step 8

Torque all 1/2" fasteners to 110 lb-ft. To ensure proper installation, the driver side and passenger side insert tubes must be drawn together with the main body assembly tube to achieve metal-to-metal contact.