

XED SERIES AMPLIFIERS



XED600.2/600.4/1200.1M

USER MANUAL

Cerwin Vega Mobile Amplifiers

Thank you for purchasing a Cerwin Vega Mobile amplifier for your car audio system. You have chosen Cerwin Vega Mobile because you deserve the best!

Cerwin Vega Mobile amplifiers are designed and engineered to the highest quality standards in the industry to create the ultimate listening experience in your vehicle. For optimal performance of this product, it is highly recommended that you have your new amplifier installed by an authorized Cerwin Vega Mobile dealer. Our authorized dealers have the necessary experience and installation equipment to ensure that your amplifier will deliver maximum performance and explain all the details pertaining to our warranty coverage as well.

If you decide to install the amplifier by yourself, please thoroughly read through this manual before getting started. This manual will help familiarize yourself with this amplifier and guide you through the installation process and procedures.

Thank you for purchasing a Cerwin Vega Mobile product and we hope to provide you with countless hours of listening enjoyment.

Please take a brief moment to register your new product. By registering your new product, you will receive benefits such as:

- Important product notifications that may pertain to your purchase.
- Confirmation and record of ownership in case of loss or theft.
- Knowledgeable customer service and technical assistance pertaining to your product.

Registration is voluntary and failure to register will not diminish your limited warranty rights.

Limited Warranty (U.S.A.)

Cerwin Vega Mobile warrants all of our amplifiers and speakers to be free of defects in materials and workmanship for a period of one (1) year.

This warranty is non-transferable and applies only to the original purchaser from an authorized Cerwin Vega Mobile dealer. If service is required and necessary under this warranty due to manufacturing defect or malfunction, then Cerwin Vega Mobile will repair and/or replace defective product with either new or remanufactured like product at no charge at our discretion.

Damage to product caused by the following will not be covered under this warranty: abuse, accident, misuse, neglect, modifications, repairing attempts, seller/installer misrepresentation.

This warranty does not cover any incidental, consequential, or cosmetic damage due to accidents or normal wear and tear, nor does it cover the cost of removing or reinstallation of the product.

Warranty is void if the product's serial number has been removed, defaced, and/or tampered with.

Warranty Procedure:

We recommend that you contact your Cerwin Vega Mobile authorized dealer where your original purchase was made to initiate all warranty claims. Our authorized dealers can guide you through the warranty procedure to ensure that your claim will be processed in a timely manner. All warranty returns must be accompanied with a proof of purchase (a copy of the original sales receipt) and be shipped freight prepaid to our facility with an RA (Return Authorization) number clearly marked on the outside of the package. Direct returns from consumers or non-authorized dealers will be refused if shipped without a valid RA number authorized by Cerwin Vega Mobile beforehand.

PRODUCT SPECIFICATIONS

	XED600.2	XED600.4	XED1200.1M
RMS Power Rating			
Max Power	600 W MAX	600 W MAX	1200 W MAX
Type			
Topology	Class AB	Class AB	Class AB
Power Supply			
Power Supply	Full PWM	Full PWM	Full PWM
Power Supply Threshold	10.0VDC - 17.0VDC	10.0VDC - 17.0VDC	10.0VDC - 17.0VDC
Idle Current	(0.7A)	(0.7A)	(0.7A)
Distortion			
THD 4 (1KHz @4Ω)	0.1%	0.1%	0.1%
S/N Ratio (A weighted @1W)	-85dBA	-85dBA	-85dBA
S/N Ratio (A weighted @ FP)	-101.1dBA	-101.1dBA	-101.1dBA
Input Sensitivity			
Low Input Level	200mV - 6.0V	200mV - 6.0V	200mV - 6.0V
High Input Level	2.0V->20.0V	2.0V->20.0V	2.8V->20.0V
Input Impedance			
Low Input Level	20 KΩ	20 KΩ	20 KΩ
High Input Level	100 Ω	100 Ω	100 Ω
Output Stage			
Output Impedance	0.011 Ω	0.0297 Ω	0.018 Ω
Damping Factor (50Hz @ 4Ω)	>70	>70	>70
Bandwidth (-3dB)	10Hz-45KHz	10Hz-45KHz	10Hz-250Hz
Crossover (-12dB/Oct)			
Variable High-Pass	50Hz - 250Hz	50Hz - 250Hz	N/A
Variable Low-Pass	50Hz - 250Hz	50Hz - 250Hz	50Hz - 250Hz
Variable Sub-Sonic	N/A	N/A	N/A
Fuse Ratings			
ATC	25A	2 x 25A	2 x 30A
Dimensions			
Length x Width x Height (inches)	10.9" x 8.875" x 2.187"	12.9" x 8.875" x 2.187"	16.8" x 8.875" x 2.187"
Length x Width x Height (mm)	278 x 225.4 x 55.6	328 x 225.4 x 55.6	427 x 225.4 x 55.6

WARNING: Prolonged exposure to sound pressure levels in excess of 100dB can cause permanent hearing loss. Cerwin Vega Mobile amplifiers can exceed that level so please exercise restraint when listening and enjoying your new amplifier.

GENERAL PRECAUTIONS

- This unit is designed for negative ground 12V DC operation only.
- Total system impedance must not be less than 2ohms, in a bridged OR stereo configuration
- Avoid installing the unit where:
 - It would be subject to high temperatures, such as from direct sunlight or hot air from the heater.
 - It would be exposed to rain or moisture.
 - It would be subject to dust or dirt.
- Do not cover the unit with carpet or wires.
- Do not use the unit with a weak auto battery. Optimum performance depends on a normal battery supply voltage.
- For safety reasons, keep the volume of your car audio system moderate while driving your vehicle so that you can still hear normal traffic sounds outside your car.

MOUNTING PRECAUTIONS

Although Cerwin Vega Mobile amplifiers incorporate heat sinks and protection circuits, mounting the amplifier in a tight space without any air movement can still damage internal circuitry over time. Choose a location that provides adequate ventilation around the amplifier. For easy system set-up, mount the amplifier so the side panel controls will be accessible after installation. To increase thermal run times on low impedance loads, an additional fan is recommended, remember any moving air across the amplifier will reduce heat.

In addition, observe the following precautions:

1. Using a felt pen mark the mounting hole locations.
2. Mounting the amplifier on carpet will significantly reduce air flow, resulting in reduced thermal run times.
3. Mount the amplifier on a solid surface. Avoid mounting to sub woofer enclosures or areas prone to vibration. Do not install the amplifier on plastic or other combustible materials.
4. Prior to mounting the amplifier, make sure not to cut or drill into the fuel tank, fuel lines, brake lines (under chassis) or electrical wiring.

WIRING PRECAUTIONS

1. Before installation, make sure the source unit power switch is in the OFF position.
2. Disconnect the negative (-) lead of the battery before making any power connections.
3. When making connections, be sure that each one is clean and secure. Insulate all of your connections. Failure to do so may damage your equipment.
4. A secure clean ground connection is critical to the performance of your amplifier. Connect the ground directly to the car chassis to minimize resistance and avoid any noise problems.
5. Add an external fuse on the amplifier's positive (+) power lead and connect it as close as possible to the vehicle's (+) battery terminal. Use a rating that equals the total current consumption at full output of all amplifiers in the system. This external fuse will protect the vehicle from short circuits that can cause a fire.

VEHICLE ELECTRICAL SYSTEM

Amplifiers (regardless of brand name) will put an increased load on the vehicle's battery and charging system. Cerwin Vega Mobile recommends checking your alternator and battery condition to ensure that the electrical system has enough capacity to handle the increased load of your stereo system. Original equipment electrical systems which are in good condition should be able to handle the extra load of any CVM amplifier without problems, although battery and alternator life can be reduced depending on your individual listening habits. To maximize the performance of your amplifier, we suggest the use of a reserve power "Stiffening" capacitor (1 Farad per 1000W).

WARNING:

Avoid running power wires near the low level input cables, antenna, power leads, sensitive equipment or harnesses. The power wires carry substantial current and could radiate noise into the audio system through the audio cables.

1. Plan the wire routing as described in the "Importance of Pre-Planning" section. Keep RCA cables close together but isolated from the amplifier's power cables and any high power auto accessories, especially electric motors. This is done to prevent coupling the noise from radiated electrical fields into the audio signal. When feeding the wires through the firewall or any metal barrier, protect them with plastic or rubber grommets to prevent short circuits. Leave the wires long at this point to adjust for a precise fit at a later time.
2. Prepare the power wire for attachment to the amplifier by stripping 5/8 inch (15.9mm) of insulation from the end of the wire. Insert the bare wire into the B+ terminal. And tighten the set screw to secure the cable in place.

WARNING:

The B+ cable MUST be fused 18" or less from the vehicle's positive battery post. Choose a location to install a waterproof fuseholder under the hood and ensure connections are water tight. If you do not use the appropriate fuseholder, the connection will eventually suffer corrosion from moisture and heat.

3. Trim the power cable within 18 inches (45.7mm) of the positive battery post and splice in a in-line fuse holder. DO NOT install the fuse at this time.
4. Strip 1/2 inch (12.7mm) from the battery end of the power cable. Crimp and solder a large ring terminal to the cable. Connect the ring terminal to the positive (+) battery post.

FUSE WIRE DIAGRAM

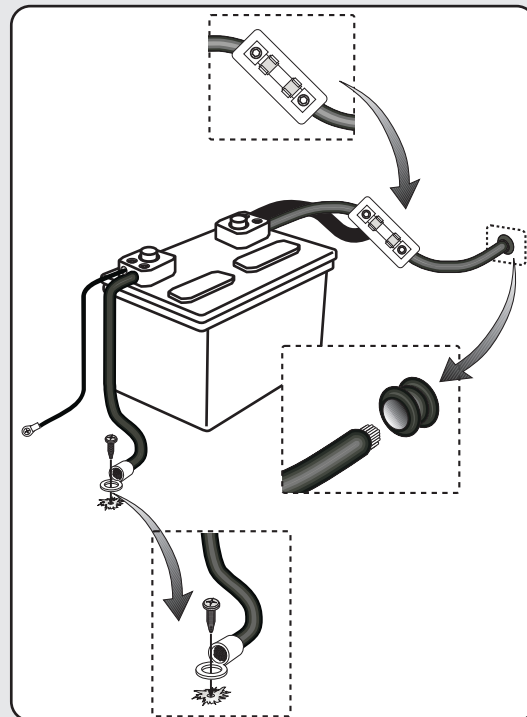

- ① **Status LED's** - These lights indicate when the amplifier is powered up normally and when there is a protection fault. The Protect LED is laminated when there is a problem with your amplifier. Please contact your authorize CVM dealer or call CVM's technical support.
- ② **HPF Crossover Adjustment** - Use this adjustment to select the crossover point. Remember that you must select the High Pass position (HPF) of the crossover adjustment switch first. The range of adjustment is limited between 50-250 Hz.
- ③ **Vega Bass Boost** - This control adds 0 to +9dB of boost at 45Hz. Be cautious when adding boost to some subwoofer systems as they may not be able to handle the additional low frequency boost. In the OdB position, no bass boost is added.
- ④ **LPF Crossover Adjustment** - Use this adjustment to select the crossover point. Remember that you must select the Low Pass position (LPF) of the crossover adjustment switch first. The range of adjustment is limited between 50-250 Hz.
- ⑤ **Crossover Selection Switch** - This switch allows you to select the crossover. Use High Pass for midrange or high frequency speakers. Use Low Pass for subwoofers. In the FLAT position, neither crossover adjustment knob has an affect and all speakers will receive the full frequency range.
- ⑥ **Input Gain Adjustment** - This control matches the preamp stage of the Cerwin-Vega Mobile amplifier to your source unit. This is NOT a volume control. The range is between aprox 200mV and 6V.
- ⑦ **RCA Input** - The RCA jacks allow for a normal Left and Right channel signal input. Simply connect to the source unit using RCA type audio cables, keeping them away from power wiring wherever possible to reduce risk of noise.
- ⑧ **Power Input Connections** - These connections are for input power, chassis ground, and remote turn-on. Use a minimum of 8 gauge wiring for power and ground connections. 4 Gauge is recommended for the mono block. The terminals will handle up to 8 gauge wiring with no problem whatsoever (4 gauge on the mono block). Be sure any wiring that passes through metal has a grommet!
- ⑨ **Power Fuses** - Standard automotive type ATC/ATO fuses are used on Cerwin Vega Mobile amplifiers. Always replace with the correct fuse size. Never insert fuses of higher values. Doing so will void the warranty of your Cerwin Vega Mobile amplifier. Also include a main fuse at the connection to the vehicle battery within 18 inches of the positive battery post. It is also important to upgrade the connection between the negative battery post and the chassis of the vehicle. This greatly reduces possibilities of weak electrical "links" in the circuit.
- ⑩ **Speaker Output Terminals** - Connect your speakers to these terminals. Stereo connections are connected as labeled. Bridged connections use the LEFT + and RIGHT - as the two connections. The 2 and 4 channel amplifiers will perform into 2 Ohm stereo loads or 4 Ohm bridged loads. DO NOT run 2 Ohm bridged loads on these amplifiers! The mono blocks will run 2 ohms mono, BUT NOT 1 ohm mono!
- ⑪ **Remote Level Control** - This port is for the remote level control (included). The control is intended to allow the user to control the level of gain up to the maximum adjustment level set on the amplifier. The control does not add additional boost, it only attenuates the setting that is fixed at the amplifier's control panel.
- ⑫ **High Level Input** - Use these inputs when there is no low-level RCA output available from your source unit. Connecting your Cerwin Vega Mobile amplifier directly to the vehicle's factory radio would be a perfect example of this.

Features

XED600.2

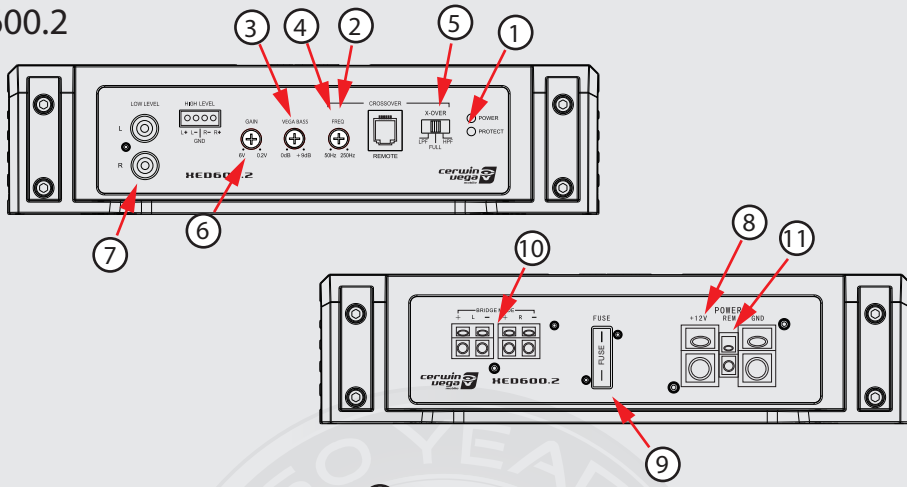

XED600.4

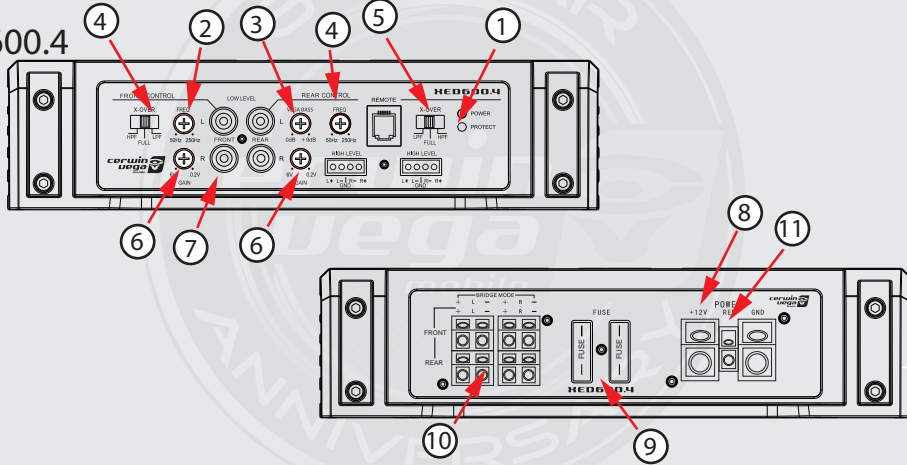

XED1200.1M

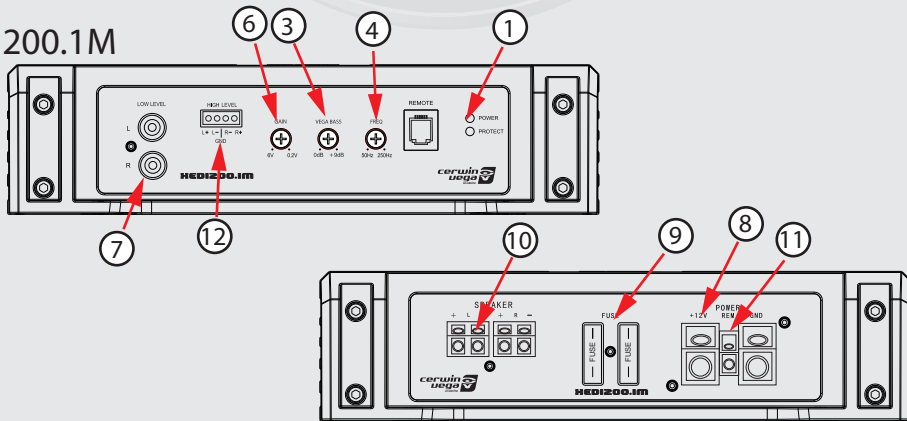

5. Prepare the ground wire for attachment to the amplifier by stripping 5/8" of insulation from the end of the wire. Always use a wire of the same gauge as the power connection, never smaller. Insert the bare wire into the GND terminal and tighten the set screw to secure the cable in place. Prepare the chassis ground by scraping any paint from the metal surface and thoroughly clean the area of all dirt and grease. Strip the other end of the wire, crimp and solder a ring connector. Fasten the cable to the chassis using a non-anodized screw with a star washer and a nut.

WARNING: It is important to upgrade the ground connection between the negative (-) battery post and the vehicle body or chassis to achieve optimum electrical performance.

FUSE CONNECTION DIAGRAM

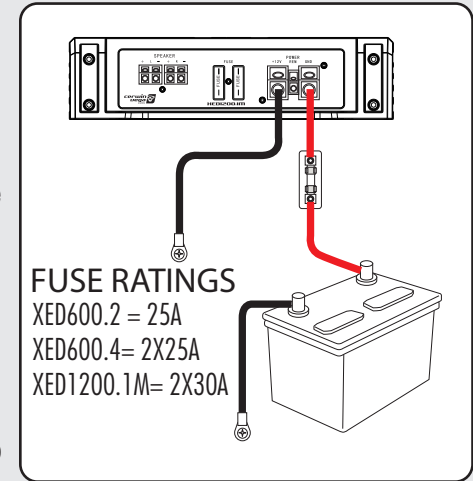

FUSE RATINGS
 XED600.2 = 25A
 XED600.4 = 2X25A
 XED1200.1M = 2X30A

6. Prepare the REM turn-on wire for attachment to the amplifier by stripping 5/8 inch (15.9mm) of insulation from the end of the wire. Insert the bare wire into the REM terminal and tighten the set screw to secure the wire in place. Connect the other end of the REM wire to a switched 12 volt positive source. The switched voltage is usually taken from the source unit's remote amp turn on lead. If the source unit does not have this output available, the recommended solution is to wire to an accessory terminal in the car's fuse block using a relay to isolate the amplifier from the vehicles accessory circuit. This however will turn the amplifier on and off with the ignition key, regardless of whether the car stereo is on or off.

7. Securely mount the amplifier to the vehicle or amp rack. Be careful not to mount the amplifier on cardboard or plastic panels. Doing so may enable the screws to pull out from the panel due to road vibration or sudden vehicle stops.

8. Connect from source by connecting the RCA audio cables to the input jacks at the amplifier.

RCA CONNECTION DIAGRAM

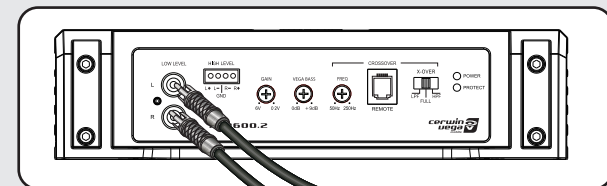

9. Connect the car speakers. Speakers impedance should never be less than 2 Ohms stereo, 4 Ohms bridged (the mono block is stable into 2 ohms). For most applications 18 gauge wire is adequate for the speaker leads. For leads in excess of ten feet, 16 gauge wire is recommended. Strip the speaker wires 1/2" (12.7mm) and insert into the speaker terminal block, then tighten the set screw to secure into place. When wiring the speakers, pay careful attention to the polarity of the terminals on the speakers and make certain they correspond to the polarity on the amplifier. DO NOT chassis ground any of the speaker leads as unstable operation or damage to the amplifier and/or speaker may result.

Placing the x-over switch in the FULL position (XED600.2, & XED600.4) sets the amplifier to Full Range. This setting allows ALL frequencies to pass to the speakers. Placing the switch in the HPF or LPF position activates the crossover. (LPF only on XED1200.1M, and it is always ON).

Placing the switch in the HPF position sets the amplifier to the High Pass Filter mode, enabling frequencies above the cutoff point to pass. For a fullrange speaker system begin tuning with the frequency set between 60Hz and 80Hz.

Placing the switch in the LPF position sets the amplifier to the Low Pass Filter mode, enabling frequencies below the cutoff point to pass. For a subwoofer system begin tuning with the frequency set between 80Hz and 120Hz.

To adjust the gain setting, turn the amplifier gains all the way down (counterclockwise). If using a remote level control (XED600.2, XED600.4(optional), & XED1200.1M) plug the level control into the amplifier and turn it to the "MAX" position. Next turn the source unit volume up to almost full volume (usually about 2/3rds of the way up) or until the output starts to distort on an oscilloscope. This will be NEARLY full volume on most source units, perhaps one or two "clicks" down from maximum volume. Next, increase the amplifier gain setting until adequate volume is achieved, or until distortion is audible and then turn it down a bit until the distortion is inaudible.

NOTE:

Ideal signal to noise and dynamic range are achieved with the gain at minimum. Most users find adequate gain and volume is achieved at less than halfway in the adjustment range. Avoid setting the amplifier gain very high as noise and distortion will increase significantly. For a more in depth level setting (gain adjustment) procedure, visit the CVM website.

The HPF or LPF crossover adjustment can now be fine tuned. If you are using the amplifier in a HPF configuration and would like the system to be a little bit louder you can increase the HP Filter frequency and reset the "Gain" of the amplifier. Raising the HPF frequency up to high however will cause a loss of mid range and bass. If you are using the amplifier in a HPF filter configuration and you hear voice or vocals coming from your subwoofer system you can turn the LP Filter frequency down (lower).

After setting the input gain adjustment and crossover, you may choose to add a small amount of "Vega Bass Boost" in the low frequency region. Remember that the Bass Boost feature will not fix a poorly designed subwoofer enclosure or subwoofers that didn't sound good to begin with.

1. Make sure any bass EQ or low frequency equalization from the source unit is set to OFF or FLAT.
2. While playing the same musical selections used during the gain setting process, slowly increase the level of the Bass EQ. You should be able to notice a obvious change between 0 and +9dB. If you do not notice much difference, then it will not serve any benefit to increase the boost further.
3. If the boost has audible benefits without adding appreciable distortion, find a level that suits your taste. Remember: it's much easier to construct the right subwoofer enclosure for your listening preferences than relying on a bass boost control to do the job!

Three Channel Mode:XED600.4

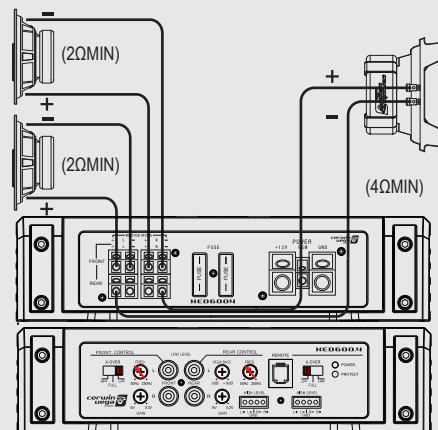

Four Channel Mode:XED600.4

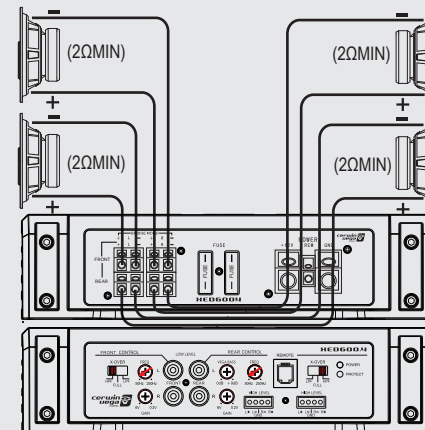

Two Channel Mode:XED600.2

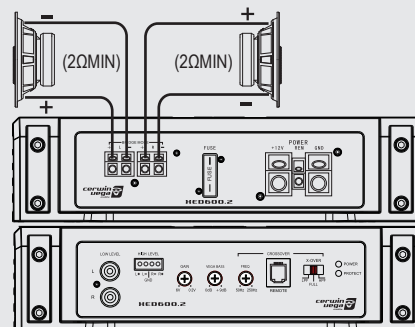

One Channel Mode:XED600.2

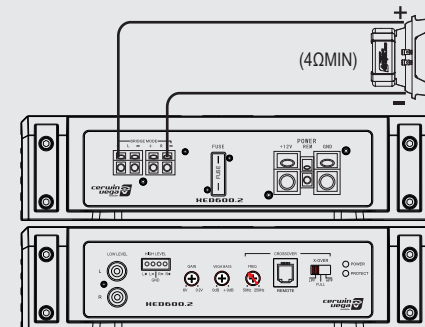

Two Woofers Mono Block:XED1200.1M

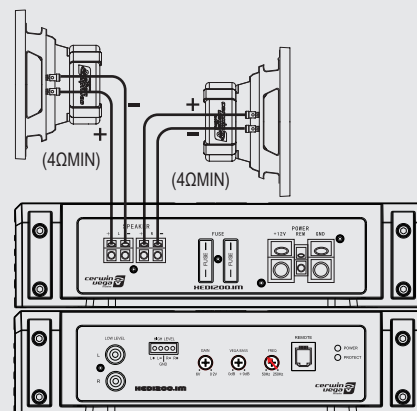

One Woofer Mono Block:XED1200.1M

