



**KIA RIO 5  
2012 and Up  
Roof Rack Installation Guide**

**PART No.**

**59712**

**Carrying Capacity**

**50 kgs  
110 lbs**

**KIT COMPONENTS**

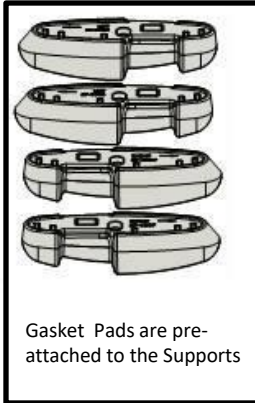
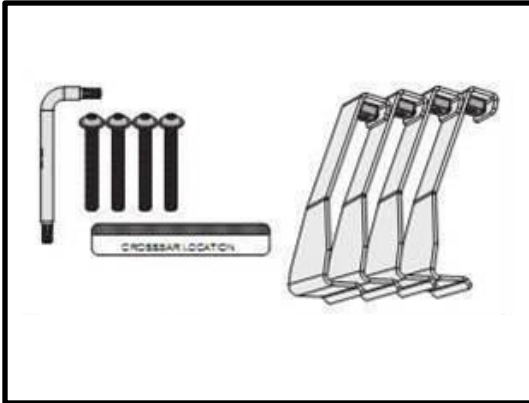

Gasket Pads are pre-attached to the Supports

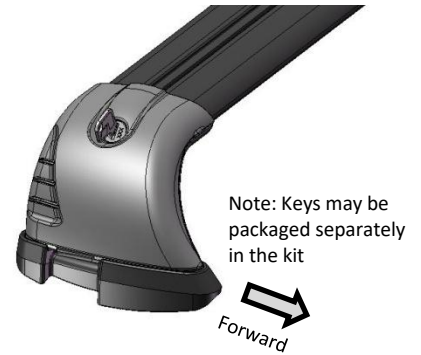

Note: Keys may be packaged separately in the kit

Forward

**Fitting Straps into End Supports**

Prior to Assembly, check that your Roof Rack Box contains all the parts as shown above. Ensure that the vehicle roof is clean and dry.

Please note that some illustrations depicted in these instructions are only representative and your items may look different. Read these instructions carefully before commencing. You can use a protective cloth when installing your racks to protect of vehicle's finish.

Ensure your straps correspond with the mounting positions on the vehicle before installing them into the End Supports. Use strap position labels to identify the correct car position.

1. Un-fasten and rotate the Covers off the End Supports. The Covers can remain attached to the Hinge on the Supports.
2. Remove the Gasket Pads by carefully pulling them off the End Supports (Pads are clipped on by "T" clips).
3. Feed the Strap neck through the cavity in the End Support (Fig 1a). When the Neck is through rotate the Strap down and then push up to align the bolt hole and the cage nut.
4. Use the supplied "L" wrench to feed the bolts into the cage nuts (Fig 1b). The "L" wrench is located inside the support.
5. Leave approximately 1" (25mm) of gap between the top of the Strap and the bolt head. This will aid in installation to the door frame (Fig 1c)

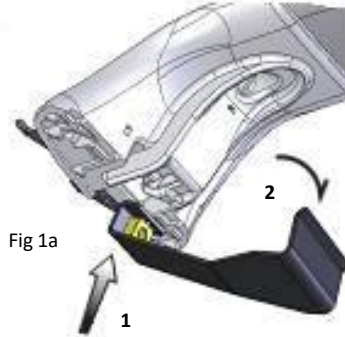

Fig 1a

TIP: Pull the Buffer Strips back approximately 1-1/2" (40mm) to allow good access for the "L" wrench to fit into the bolt head.

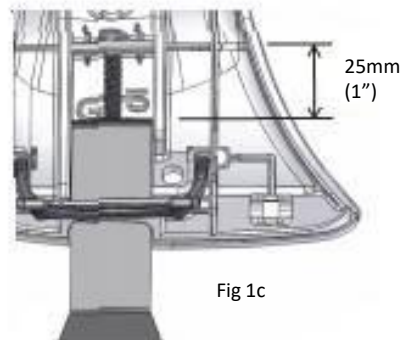

Fig 1c

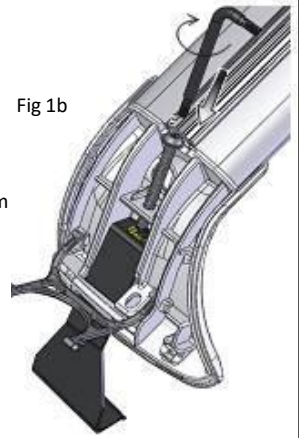

Fig 1b

**Placement of End Supports onto Vehicle Roof**

6. The Gasket Pads all have vehicle roof position text on the top inside surface. Left (Drivers side), Right (Passenger side) These can now be replaced on the end supports. Re-fasten using the T clips
7. Using the vehicles B pillar place the cross bars as specified in ( Fig 2 a & b) Note: Gasket only shown for clarity.

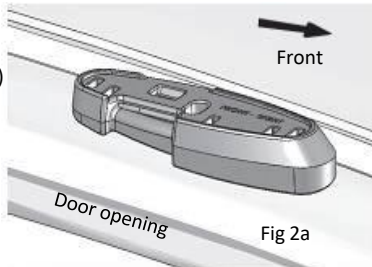

Fig 2a

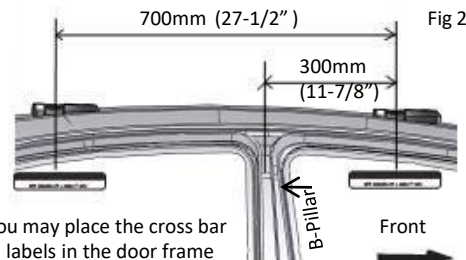

Fig 2b

Note: You may place the cross bar position labels in the door frame below the Straps for future reference.

## Installation Instructions: KIA RIO 5 2012 and Up

8. With one strap loosely mated around the door frame, hold the other side Strap out from the body side and place into the door frame. (Fig 2c)  
Ensure the rubber pads on the straps are in place to avoid paint damage.

9. Using the supplied "L" wrench tighten the bolts to pull the Straps up towards the door frame. (Fig 2d)  
Tip: While tensioning the Straps alternate from side to side to ensure even tension on both sides.

**Ensure bars are parallel and straps are tightened fully. Perform a check by tugging on the cross bars.**

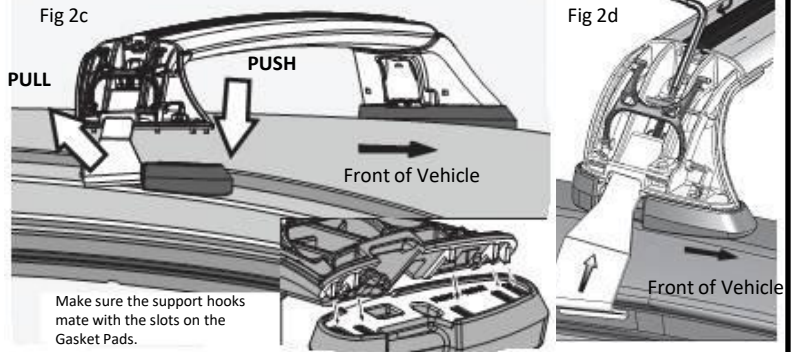

## Attaching Covers to End Supports

Should you need to remove your GTX covers the following describes the replacement and use.

10. Locate the ends of the Hinge with the Cover hinge holes. Flex the Hinge ends in and push through the Cover holes until the capped ends engage (you'll hear and audible click) (Fig 3a & b)

11. To fully extend the Covers away from the Support (to access the Accessory Channel or mounting hardware) Pivot the Cover on the Hinge while pushing down on the top of the Cover (Fig 3c)

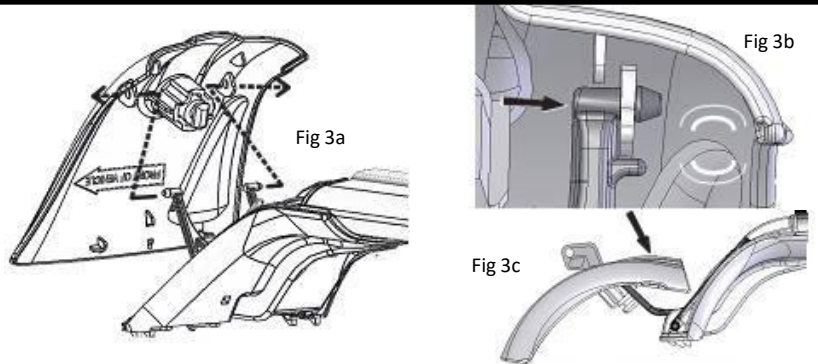

## Locking Covers and Mounting Accessories

12. You are now ready to mount your accessories examples: Bike, Kayak, luggage carriers by using the global channel if applicable. "T" bolts are available to mount accessories (Fig 4a)  
Be sure to cut your buffer strips to size to completely cover your channel once the accessories are mounted.

13. Lock all four covers into place using the keys provided (Fig 4b). Store your keys in a safe place such as the glove box or key ring. Replacement locks and keys are available as service items.

14. Ensure all covers are pushed up hard against the End Supports (Fig 4 c & d). You'll hear an audible "click" when the cover is fully engaged.

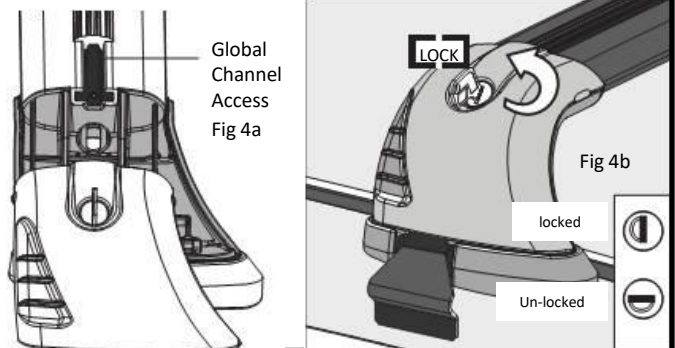

## General Usage Information

\* It is essential for the proper assembly, operation and use of the Roof Rack that the instructions and safety precautions supplied are strictly observed.

\* The maximum permissible load for your roof rack is the lower of the maximum load capacity specified in you owners manual or specified on your roof rack load label. Do NOT exceed the maximum load capacity.

Maximum load capacity equals the weight of the rack + accessories + weight of cargo.  
Ensure your vehicle's function is not impaired before driving.

Any weight carried on the vehicle will adversely affect its handling particularly in cornering or in a cross wind and the vehicle should therefore be driven with increased caution. Check the function of all doors and sunroof before driving.

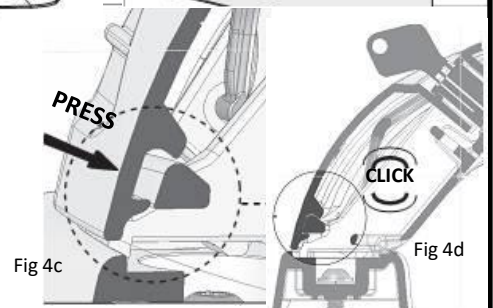

Learn more about roof racks and cargo carriers we have.