



RHINO-RACK

Aerodynamic & Heavy Duty Roof Rack Systems

Landrover Discovery 3 - Rhino Tracks.

Place these instructions in the vehicle's glove box after installation is complete.

Important: Please read these instructions carefully prior to installation. Please refer to your fitting instruction to ensure that the roof racks are installed in the correct locations. Check the contents of kit before commencing fitment and report any discrepancies

Parts List

Maximum carrying capacity: 75kg

Item.	Component Name.	Qty.	Part No.
1	Front left End cap FL.	1	M253
2	Front Right End cap FR.	1	M254
3	Rear Left End Cap RF.	1	M255
4	Rear Right End Cap RR.	1	M256
5	M6 x 20 Security Screws.	6	B062
6	M6 Spring Washer.	6	W003
7	M6 Flat Washer.	6	W004
8	M6 x 16mm Flat Washer.	4	W031
9	M6 Retaining Washer.	4	C461
10	Right Side Track.	1	A314
11	Left Side Track.	1	
12	Self Tapping Screw.	2	B083
13	Rivet	2	H007
14	5mm Security Allen Key.	1	H021
15	Fitting Instruction.	1	RTS-502

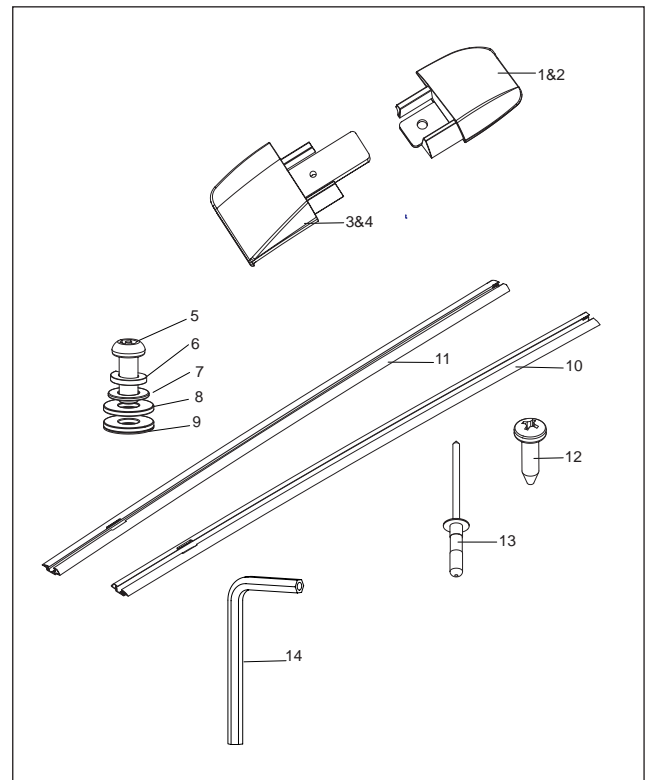

Tools & Materials Required.

- Marking pen.
- 5mm Security Allen key, provided in kit.
- Phillips screw driver.
- Flat Head screw driver.
- Measuring tape.
- Pop rivet gun.
- Drill wth 5mm drill and drill stop.
- Vacuum cleaner.
- Side cutters.
- Cold Gal paint.
- Silicone or Butyl Mastic sealer.

Layout

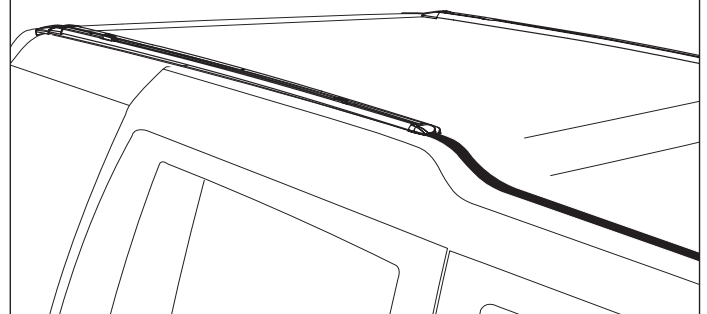

Care Instruction:

Clean vehicle roof prior to fitting Rhino Heavy Duty Racks.

1 Measure from the rear end of the gutter strip 1530mm and mark the strip and remove strip. Cut the strip at the mark, discard the longer piece. Clean the gutter, clip the front shorter piece into the gutter. Repeat other side.

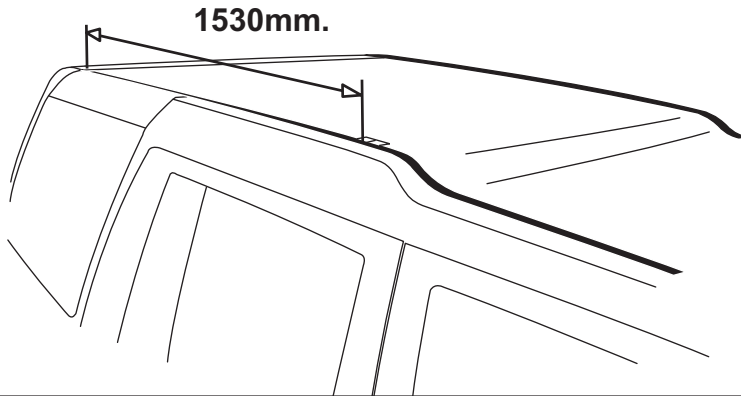

Carefully remove the six plastic plugs from the top of the nutserts in the roof gutter to expose the M6 thread.

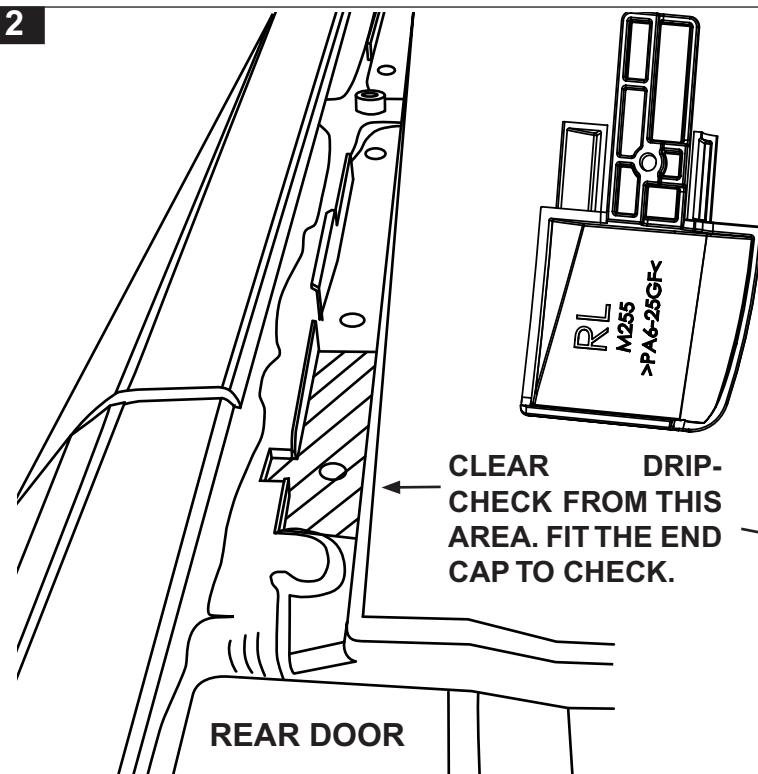
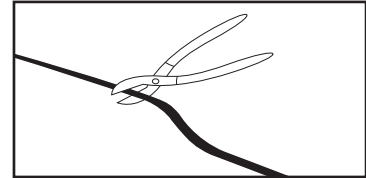
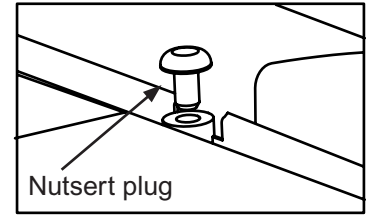

The rear end caps must fit fully down onto the gutter surface, all the drip-check were the end cap fits must be removed, then check that the end caps fit. Cold Gal paint the area were the drip-check has been removed.

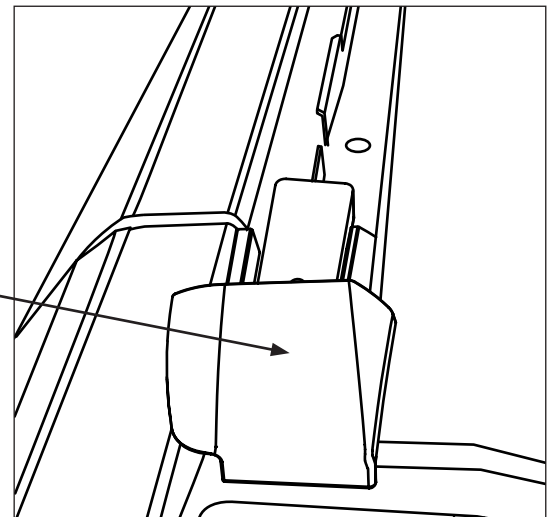

3 Knock the front and rear end caps into the tracks. The end caps are marked on the underside, the RR & RL are the rear end caps, FR & FL are the front end caps. The rear end caps are fitted to the track at the cutout end. **Rear end caps only**, screw the self-tapping screw through the track and into the rear end caps prior to fitting the tracks. **Refer notes on page 4, on riveting the rear end caps to the roof gutter for extended loads.**

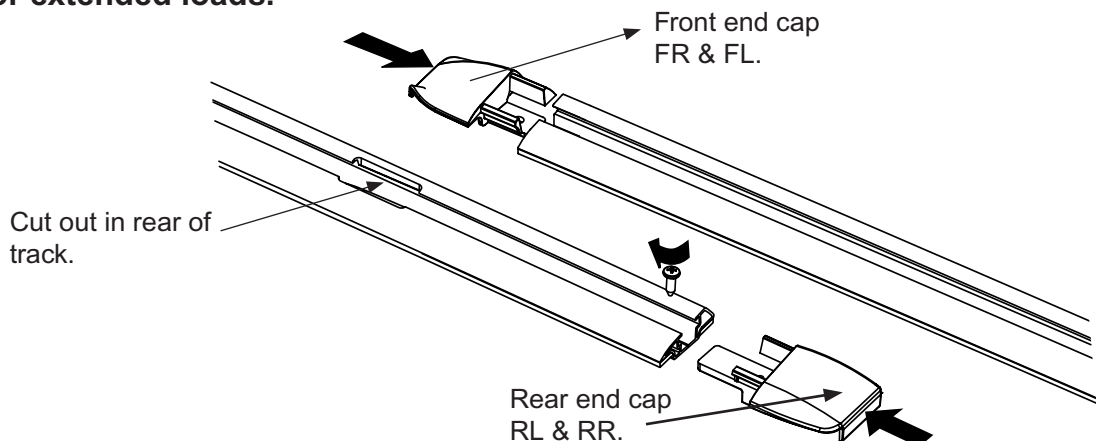

4

Middle two screws only. Assemble the spring washer and smaller flat washer onto the M6 security screws. Insert the screw assemble through the holes in the tracks, turn track over, assemble the larger flat washer and retaining washer onto the screws. Repeat on other track.

M6 x 20 Security screw.
Spring washer.
Flat washer (small).

Flat washer (large).
Retaining washer.

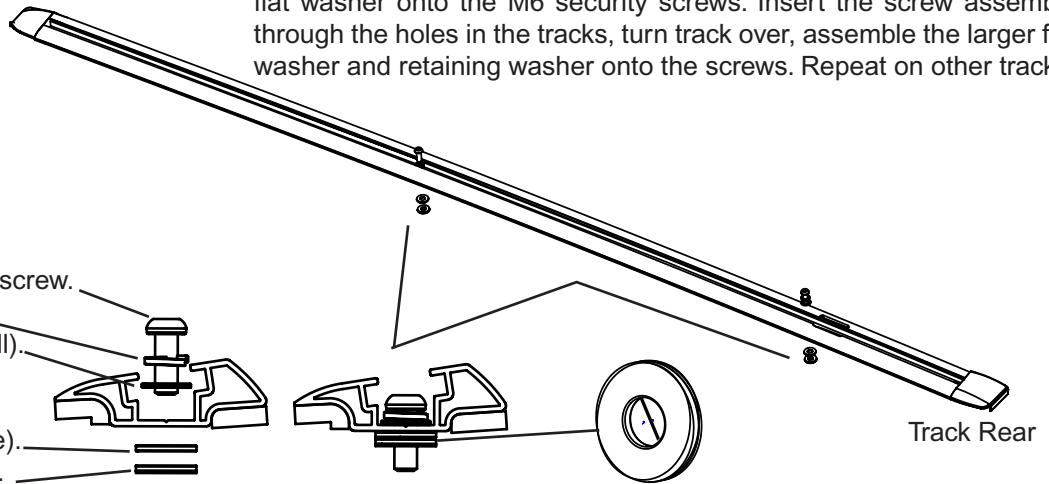

The retaining washer must be assembled last with the rubber pad up against the flat washer (Large).

5

Rear End Cap only.
Apply Silicone or Butyl Mastic to the end cap to roof contact area, prior to fitting the tracks.

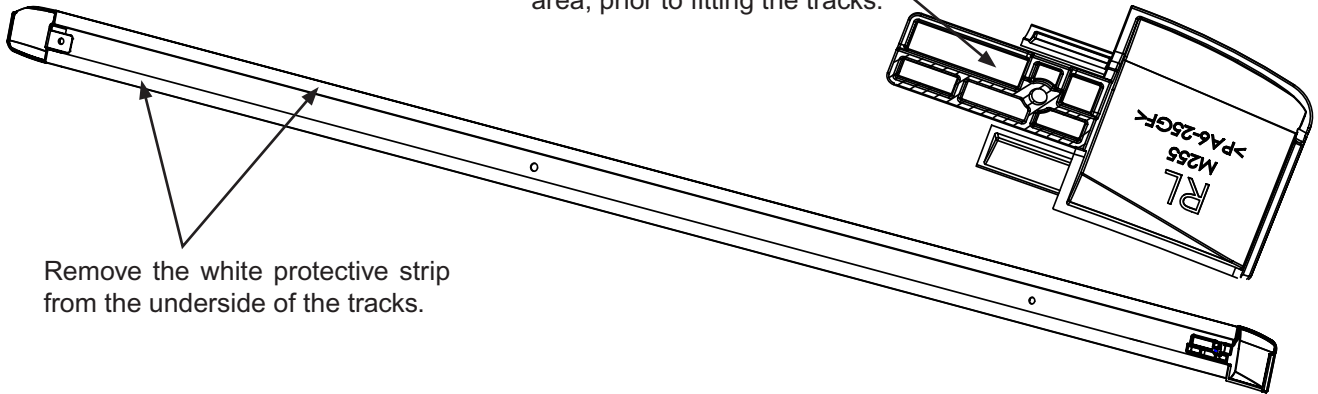

Remove the white protective strip from the underside of the tracks.

6

Place the tracks into the roof gutters, cutout to the rear, pointed edge to the outside of the vehicle. **Front screws only.** Assemble the spring washer and flat washer onto the M6 x 20 security screw, insert into the front track hole and screw into the roof nutserts, leave loose. Engage the middle and rear screws into the remaining nutserts progressively tighten all three screws.

This edge to the outside.

Front Screws only.
M6 x 20 Security screw.
M6 Spring washer.
M6 Flat washer.

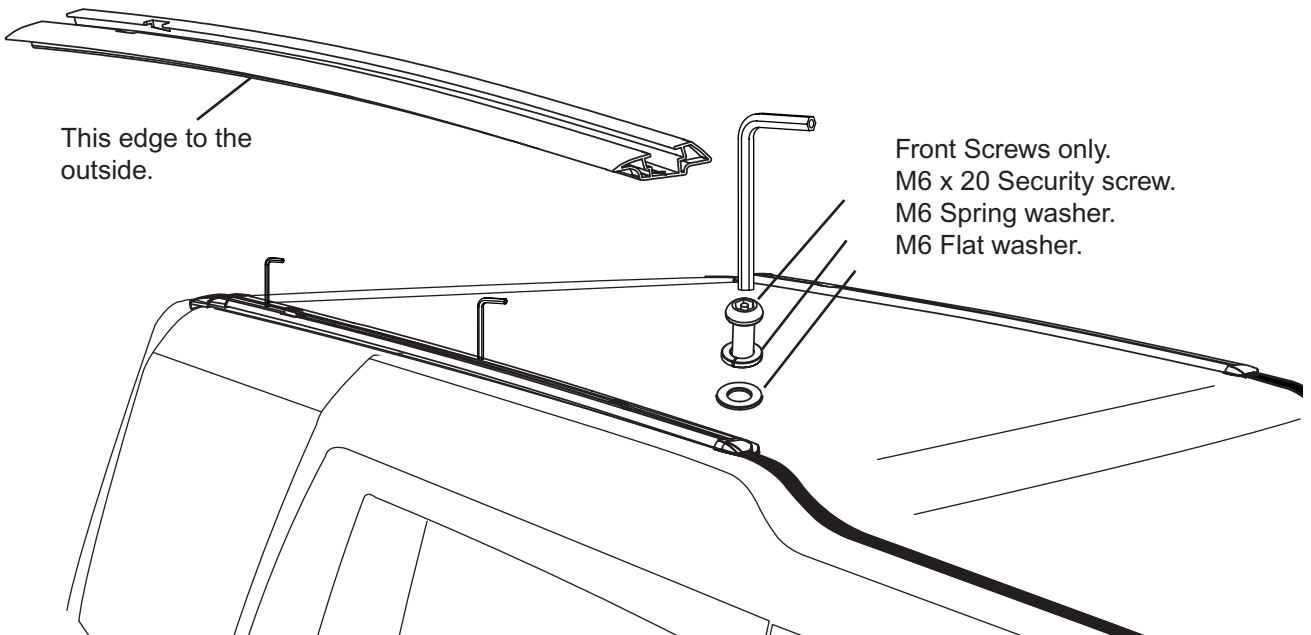

Alternative Instructions for fitting a rivet as an extra attachment point for accessories which require the crossbar to be fitted rearwards of the last mounting screw. Accessories which require this attachment are the boat loader and large roof trays.

- 7** If previously installed remove the self tapping screw from the rear end cap.

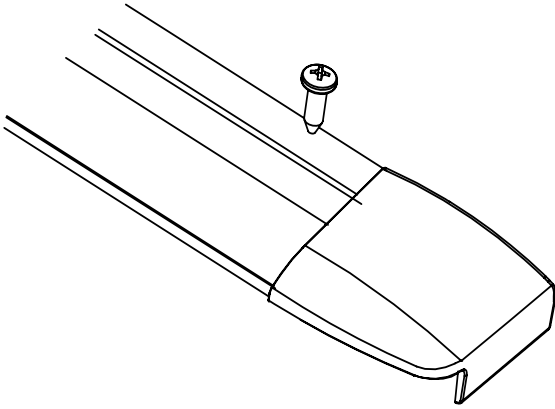

- 8** Using a 5mm drill with a drill stop attached, drill through the track and end cap to mark the gutter.

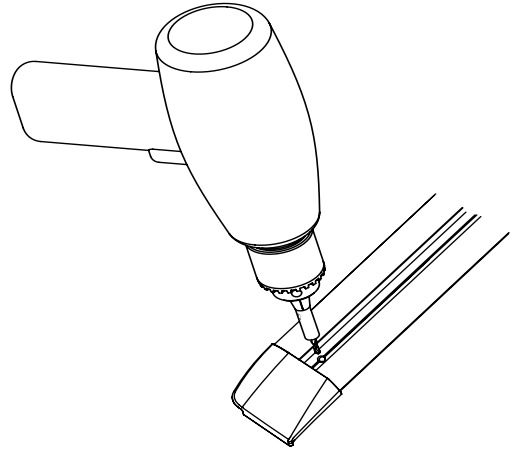

- 9** Remove the track complete and drill the through the gutter roof at the mark, then vacuum the drill swarf from the gutter.

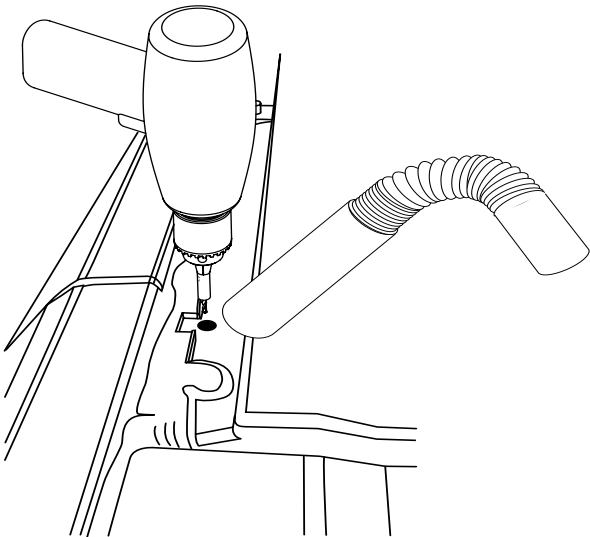

- 10** Apply Silicone or Butyl Mastic sealant Liberally around the drilled hole and the base of the end cap.

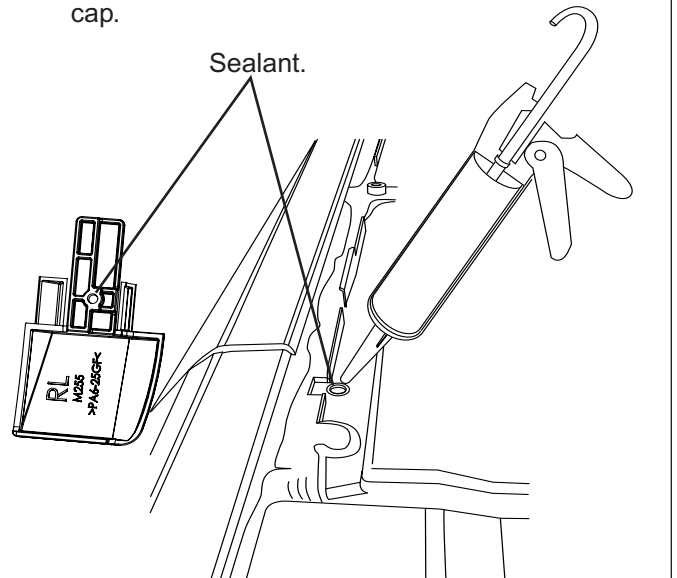

- 11** Place the track into the roof gutter and insert all screw as perviously instructed. Insert the rivet through the track and end cap, Use a pop rivet gun to secure the rivet. Repeat all steps on the other track.

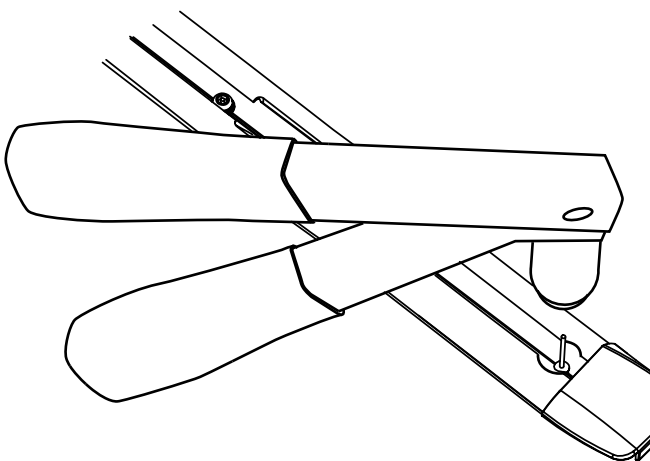

Important Information

Maximum carrying capacity: 75kg

Recommendations:

Do not fit the rear cross bar behind the rear track to roof attachment screw unless the rear of the track is riveted to the roof, refer Page 4.

It is essential that all bolt connections be checked after driving a short distance when you first install your cross bars.

Bolt connections should be checked again at regular intervals (probably once a week is enough, depending on road conditions, usage, loads and distances travelled). You should also check the cross bars each time they are refitted.

Make sure to fasten your load securely. Please ensure that all loads are evenly distributed and that the centre of gravity is kept as low as possible.

Use only non-stretch fastening ropes or straps.

Sensitivity to crosswinds, behaviour in curves and braking.

The handling characteristics of the vehicle, changes when you transport a load on the roof. For safety reasons, we recommend you exercise extreme care when transporting wind-resisting loads; special consideration must be taken into account when braking.

Please remove cross bars when putting vehicle through an automatic car wash.

Load Ratings.

Maximum permissible load is 75kg per pair of cross bars (include the weight of the cross bars, 5kg). When cross bars are to be used in off-road conditions, please build a safety factor of 1.5 into this load limit. Although the cross bars are tested and approved to AS1235-2000, Australian road conditions can be much more rigorous. However, increasing the number of cross bars does not increase the vehicles maximum permissible roof loading.

Note for Dealers and Fitters.

It is your responsibility to ensure instructions are given to the end user or client.

Rhino-Rack
3 Pike Street, Rydalmere,
NSW 2116, Australia.
(Ph) (02) 9638 4744
(Fax) (02) 9638 4822

Document No: RR140
Prepared By: Alan Marshall
Authorised By: Gary England

Issue No: 02
Issue Date: 20/10/2006

These instructions remain the property of Fetovu Pty Ltd T/as Rhino-Rack and may not be used or changed for any other purpose than intended.