

EFR 6758-F(v) 250 - 500 HP Turbo

EFR SERIES



Key Turbo Features

- Gamma-Ti turbine wheel
- Dual ceramic ball bearing assembly with metal cage
- Large internal wastegate
- V-Band Inlet Connection

Not Included with Turbo Assemblies:

- Speed sensor
- Turbine outlet V-Band
- Turbine inlet gasket
- Oil drain gasket or drain port fitting

COMPRESSOR MAP

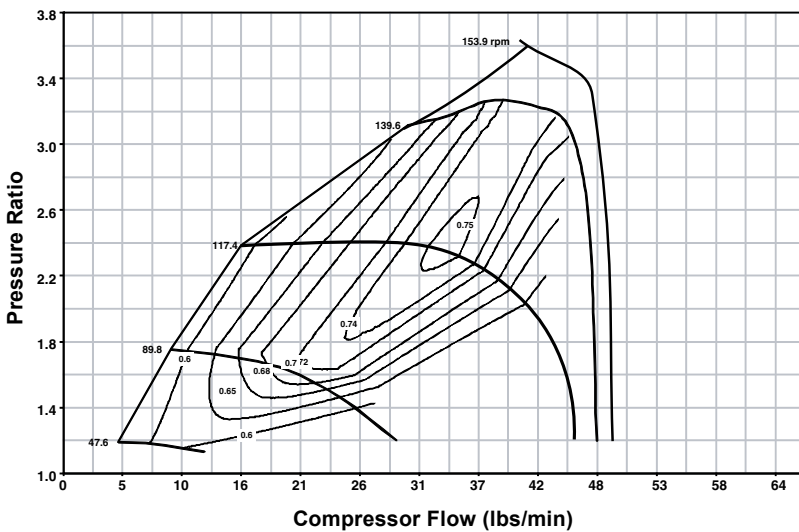

TURBINE HOUSING OPTIONS

Turbine Housing Part Number	A/R	Inlet Flange Shape	Housing Config
11581008000	0.85	T25	Single Scroll WG
11581008002	0.80	T4	Twin Scroll WG
11581008003	0.85	V-Band	V-Band, Non WG
11581009006	0.64	T25	Single Scroll WG

Turbo Part #	Turbo Frame Size	Super Core Part #	Comp. Wheel Outer Dia. (mm)	Comp. Wheel Inducer Dia.	Turbine Wheel Outer Dia.	Turbo A/R	Inlet Flange Config
11589880035	B1	11587105001	67	54	58	0.85	V-Band

TURBO FRAME DIMENSIONS

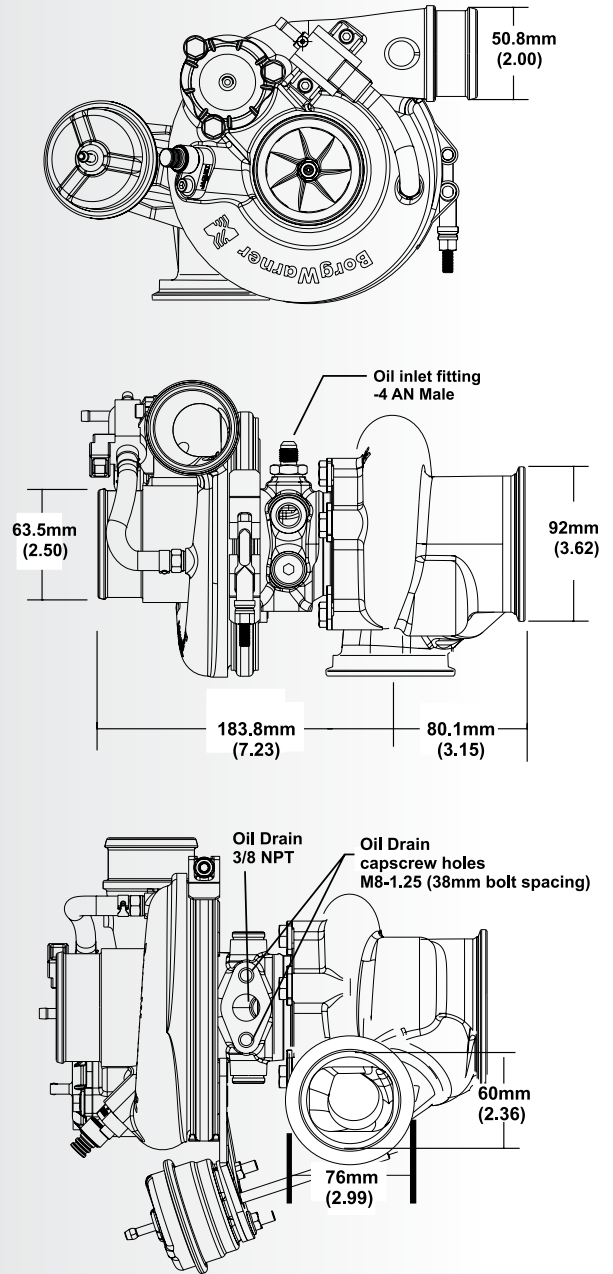

SUPER CORE CONFIGURATION

The following parts are not included as part of the super-core assembly: turbine housing, assembly clamp plate hardware, wastegate parts.