



# BX3839

## 2015 Volkswagen Golf GTI (with ACC) Installation Instructions

**Attachment Tab Height: 12"**

**Attachment Tab Width: 28"**

**Please read BOTH these Installation Instructions and the General Information sheet prior to installing or operating this equipment.**

1. Blue Ox® towing products and accessories are intended to be installed by Blue Ox® Dealers who are familiar with our products and have the equipment and knowledge necessary to do "it work".
2. Many Blue Ox® baseplates are designed to use existing holes and hardware to mount the baseplate to the towed vehicle. Even though bolts are there, do not assume they are adequate for baseplate mounting. Always use the hardware supplied in the hardware kit and existing hardware as specified in the installation instructions.

**Bolt Torque Specifications**  
Torque in Foot-Pounds for Inch Bolts

Bolt Size	Grade 5	Grade 8
1/4"	10	14
5/16"	19	29
3/8"	33	47
7/16"	54	78
1/2"	78	119
5/8"	154	230
3/4"	257	380

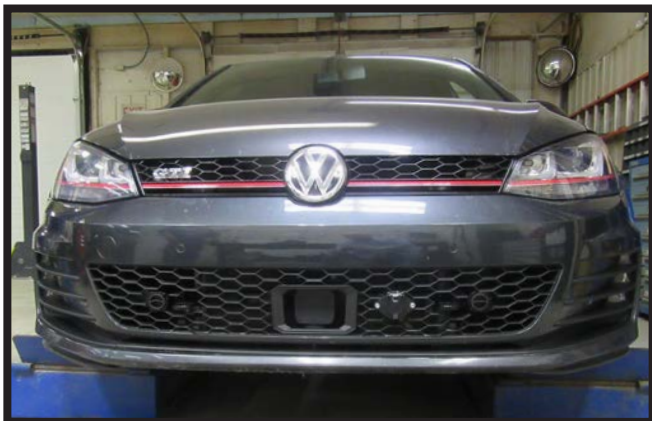

**Bolt Torque Specifications**  
Torque in Foot-Pounds for Metric Bolts

Bolt Size	Grade 8.8	Grade 10.9
6MM	6	8
8MM	16	22
10MM	31	40
12MM	54	70
14MM	89	117
16MM	161	230
18MM	222	318

**Reference your vehicle owner's manual for manufacturer's towing specifications.**

**! WARNING**

Failure to read and follow these instructions could result in separation of the towed vehicle from the tow bar, causing property damage, loss of towed vehicle, personal injury or death.

BX3839  
2015 Volkswagen Golf GTI (with ACC)  
Installation Instructions

**Instruction Notes:** The fascia, windshield washer fluid reservoir, bumper and headlight are removed and reinstalled for the baseplate installation. Some drilling and trimming is required.

Place all components that are removed on a flat, sturdy surface. All items will be reinstalled unless otherwise noted after the baseplate is installed.

The dimensional variations between otherwise identical vehicles can be considerable. While the baseplate was designed for easy installation, it may be necessary to tailor the baseplate slightly to compensate for vehicle manufacturer's tolerances.

The BX8869 Tail Light Wiring Kit is recommended for this vehicle.

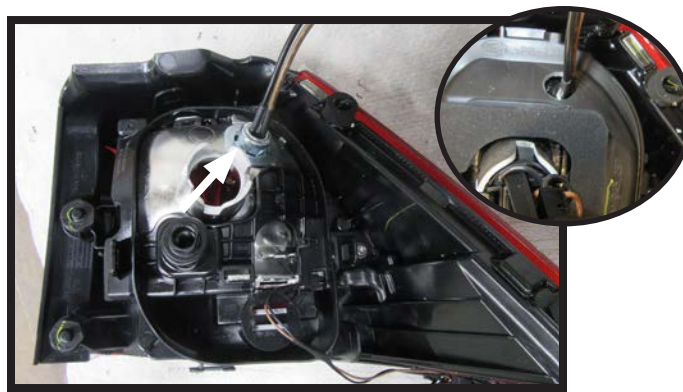

Drill a hole according to the tail  
light wiring kit instructions.

### **NOTICE**

- Handling of some cosmetic parts when installing this product may require the use of protective covers, rags, specialty tools, etc. to prevent damage.
- When using power drills be aware of the dangers of torque and drill bit length.
- When using a reciprocating saw be aware of objects behind the cutting surface.
- Use a good quality paint to spray cut edges of frame to prevent rusting.
- Be sure that **ALL** electrical connections are plugged in and accessories are functioning properly before reinstalling the fascia.
- The baseplate is computer tested to your vehicle's GVWR, exceeding this weight will void the manufacturer's warranty.
- Be sure to use a sufficient amount of Loctite® Red on all bolt threads before tightening. Tighten all bolts according to the torque chart provided unless specified.
- Dealer or installer be certain the user receives these instruction sheets.
- If the baseplate is in an accident, it must be replaced. **DO NOT** use it again! An accident can cause unseen damage and using it again could result in more damage or serious injury. **DO NOT** use the baseplate if it is damaged or missing parts.

# BX3839

## 2015 Volkswagen Golf GTI (with ACC)

### Installation Instructions

#### Tools Required

Large Vise Grip	Flat Screwdriver
Utility Knife	Reciprocating Saw
Torque Wrench	Drill
Tape Measure	Loctite® RED
3/8" Drill Bit	10MM Socket
7/16" Wrench	16MM Socket
9/16" Wrench	7/16" Socket
5/16" Nut Driver	9/16" Socket

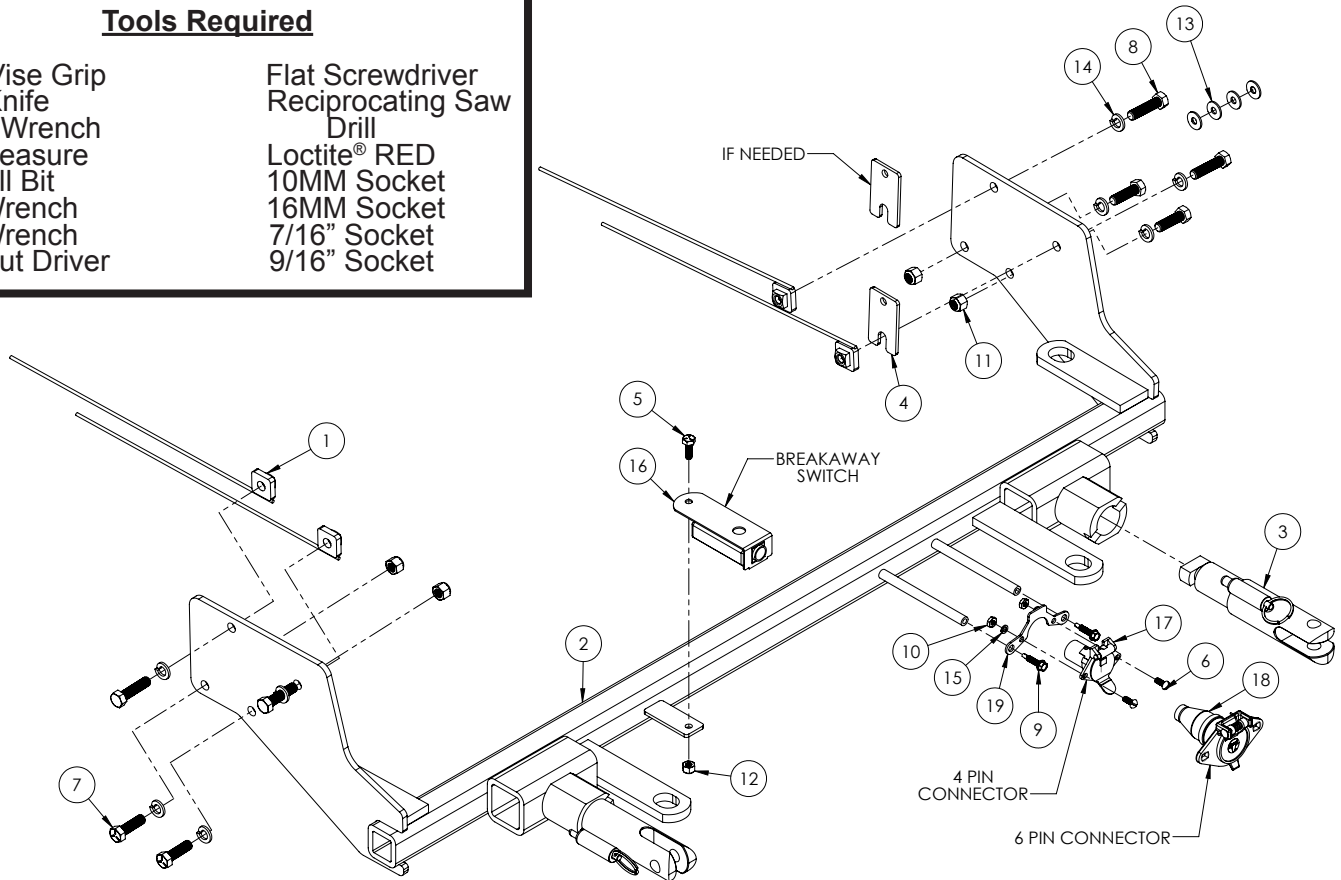

Item No.	Part No.	Description	Qty.
1.....	61-5208 .....	3/8" Nut Plate w/ 14" Wire .....	4
2.....	61-7998 .....	BX3839 Baseplate.....	1
3.....	62-3468 .....	Attachment Tab Assembly with Hole .....	2
4.....	101-9767 .....	10 GA Spacer w/Open 7/16" W x 3/4" LG Slot.....	2
5.....	201-0050 .....	1/4"-20 x 3/4" Hex Head Bolt, Grade 5, ZP .....	1
6.....	201-0192 .....	#10-32 1/2" Round Slotted Head Screw.....	2
7.....	201-0368 .....	3/8"-16 x 1-1/4" Hex Head Bolt, Grade 5, ZP .....	4
8.....	201-0440 .....	3/8"-16 x 1-1/2" Hex Head Bolt, Grade 5, ZP .....	4
9.....	201-0979 .....	#12-14 x 1" Self Drilling Screw, ZP.....	2
10.....	202-0047 .....	#10-32 Hex Nut .....	2
11.....	202-0090 .....	3/8"-16 Hex Nylon Insert Lock Nut, ZP.....	4
12.....	202-0102 .....	1/4"-20 Hex Nylon Nut, ZP .....	1
13.....	203-0001 .....	1/4" Flat Washer, ZP.....	4
14.....	203-0010 .....	3/8" Lock Washer, ZP .....	8
15.....	203-0054 .....	#10 Lock Washer, ZP .....	2
19.....	299-0685 .....	Electrical Bracket, ZP .....	1
20.....	226-0046(not shown) .....	Class III Safety Cables .....	2
21.....	229-0359(not shown) .....	3/8" Quicklink, ZP .....	2
22.....	290-0437(not shown) .....	Black Cap Plug Receiver.....	2

#### **Important:**

Use only genuine factory replacement parts on your baseplate. Do **NOT** substitute homemade or non-typical parts. If a bolt is lost or in need of replacement, for your safety and the preservation of your baseplate, be sure to use a replacement bolt of the same grade (In most cases it will be Grade 5, please reference the parts list above). Replacement parts may be ordered through your nearest Blue Ox® Dealer or Distributor. Failing to follow and/or altering these installation instructions in either installation or required equipment will void the manufacturer's warranty. Towing behind a non-motorized vehicle will void the warranty.

BX3839  
2015 Volkswagen Golf GTI (with ACC)  
Installation Instructions



1. Using a T25 Torx, remove the two (2) bolts from the top edge of the grille. There is one (1) on each side. Unsnap the grille from the vehicle and set aside.



2. Using a T25 Torx, remove the four (4) bolts from the wheel well. There are three (3) along the edge (white) and one (1) at the fascia joint (gray). Do this on both sides of the vehicle.

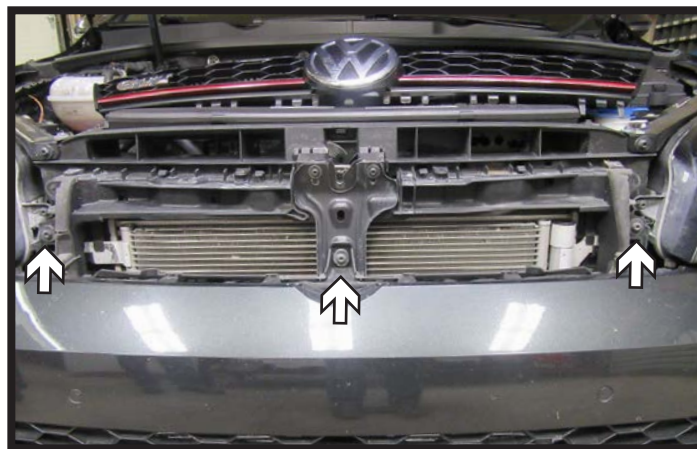

3. Using a T30 Torx, remove the three (3) bolts from the fascia brace.

BX3839  
2015 Volkswagen Golf GTI (with ACC)  
Installation Instructions



4. Using a T25 Torx, remove the seven (7) bolts from the underside of the fascia. There are two (2) on each side in each corner and three (3) across the middle.  
Remove the fascia from the vehicle, disconnecting any electrical connections and set aside.



5. Using a 5/16" Allen socket or wrench, remove the screw from the horn bracket and set the horn assembly aside to be reinstalled later. Do this on both sides of the vehicle.

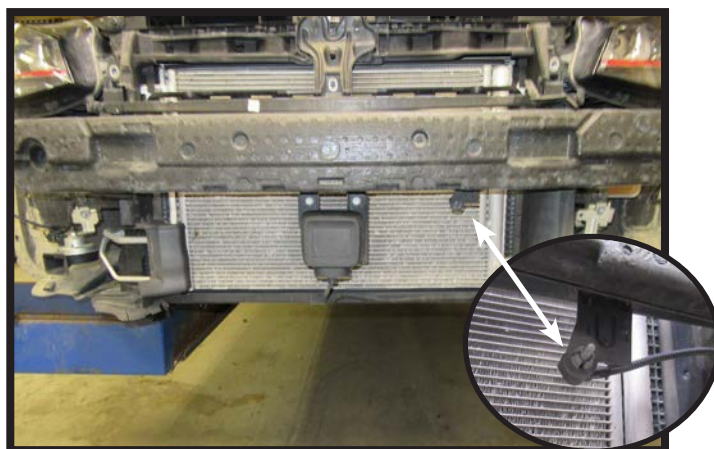

6. Remove the styrofoam support from the face of the bumper.  
Unsnap the temperature sensor from the bottom side of the bumper and set aside.

BX3839  
2015 Volkswagen Golf GTI (with ACC)  
Installation Instructions

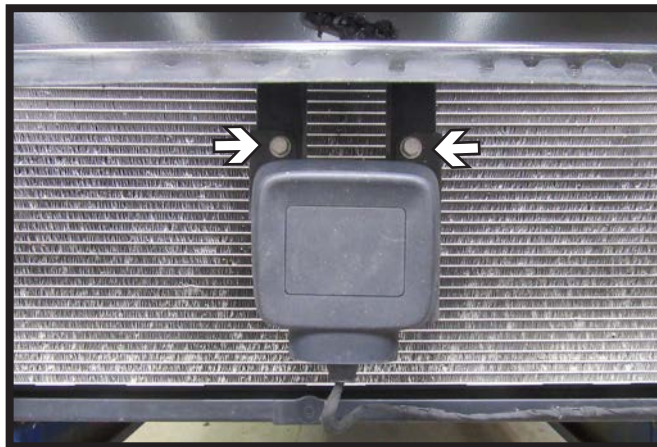

7. Using a 10 MM socket remove the (2) bolts attaching the Adaptive Cruise Control (ACC) to the bumper. Let hang to be reattached later.

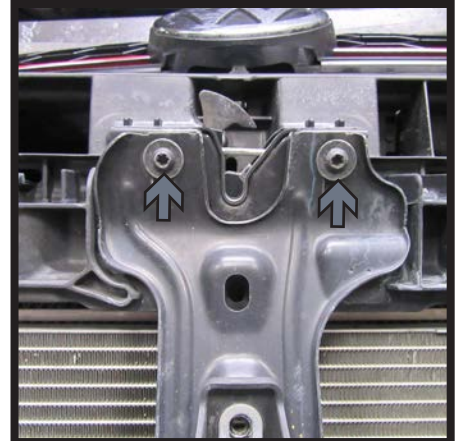
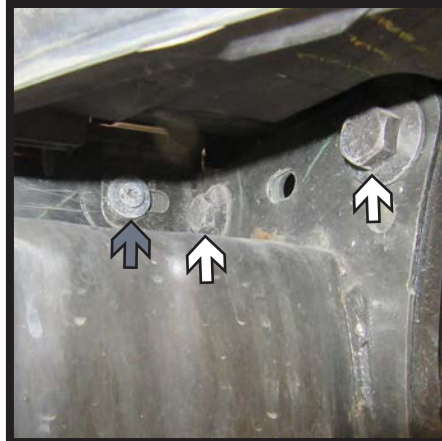
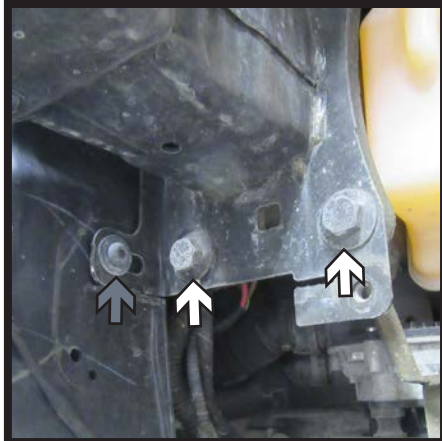

8. Using a 16MM socket, remove the eight (8) bolts from the bumper. There are four (4) on each side, two (2) on top and two (2) on bottom (white).

Using a T30 Torx, remove the six (6) bolts from bumper. There are two (2) on each side, one (1) on top, one (1) on bottom and two (2) on the upper support in the middle (gray).

Remove bumper and set aside to be reinstalled later.

BX3839  
2015 Volkswagen Golf GTI (with ACC)  
Installation Instructions

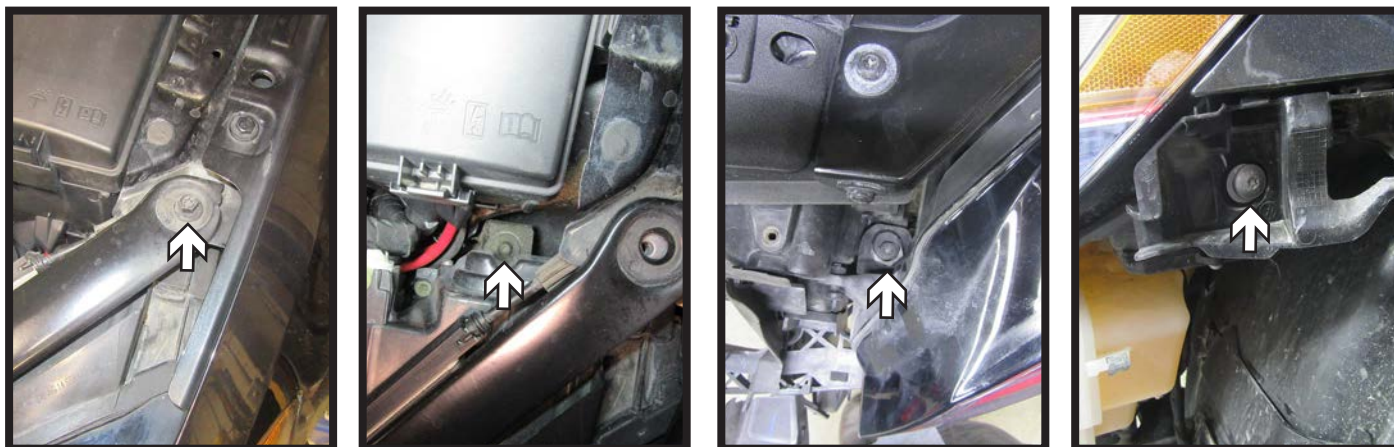

9. Using a T30 Torx, remove the four (4) bolts from the driver side headlight. There are three (3) on the top side and one (1) on the side.

Disconnect any electrical lines and set the headlight aside.

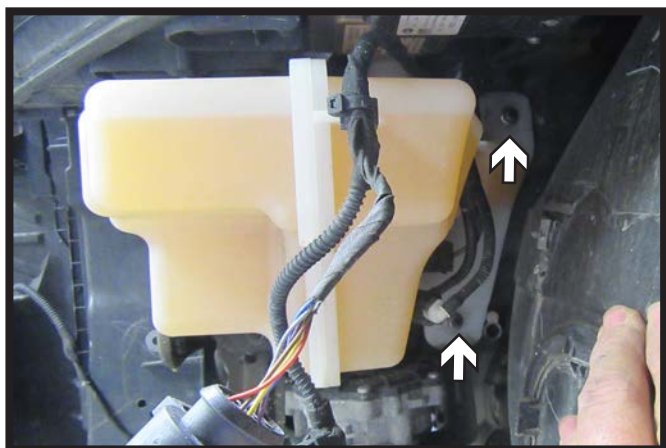

10. Using a 10MM socket, remove the three (3) nuts from the washer reservoir. Disconnect/plug all lines and set the reservoir aside to be reinstalled later.

BX3839  
2015 Volkswagen Golf GTI (with ACC)  
Installation Instructions

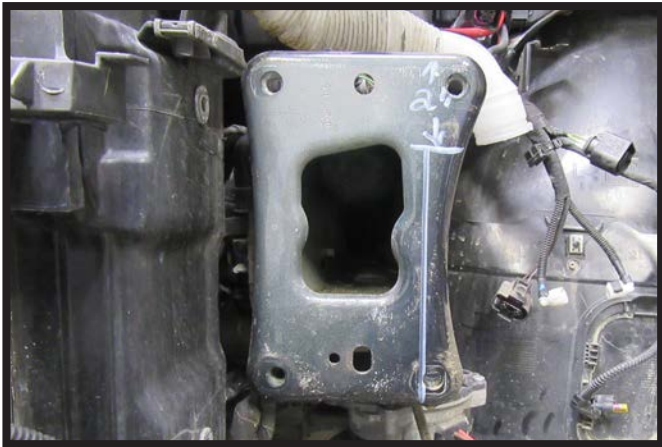

11. Using a reciprocating saw, trim the outer flange of the frame down 2" from the top and back to the face of the frame down thru the bottom lip. Do this on both sides of the vehicle.



12. Temporarily reinstall the bumper. Mark the backside of the mounting flange along the cuts of the frame. Remove and trim these areas on both sides of the bumper with a reciprocating saw. Then fully reinstall the bumper and plastic fascia brace.

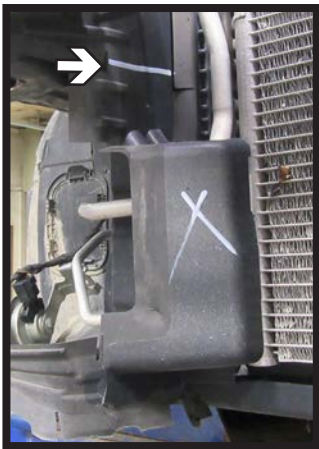

13. Trim the plastic shielding off just below the bumper on both sides of the vehicle. The shielding is not reinstalled.

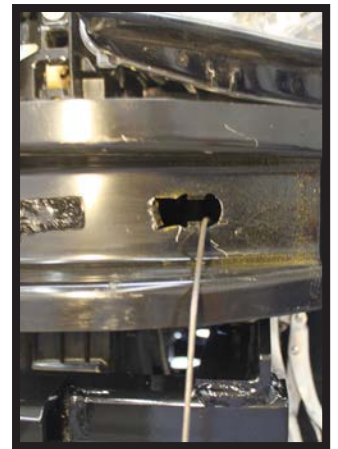

14. Using a 1-1/4" hole saw, drill an access hole on the underside of the bumper on the passenger side only (left).  
Using a reciprocating saw, enlarge the existing hole on the driver side of the bumper (right).



BX3839  
2015 Volkswagen Golf GTI (with ACC)  
Installation Instructions

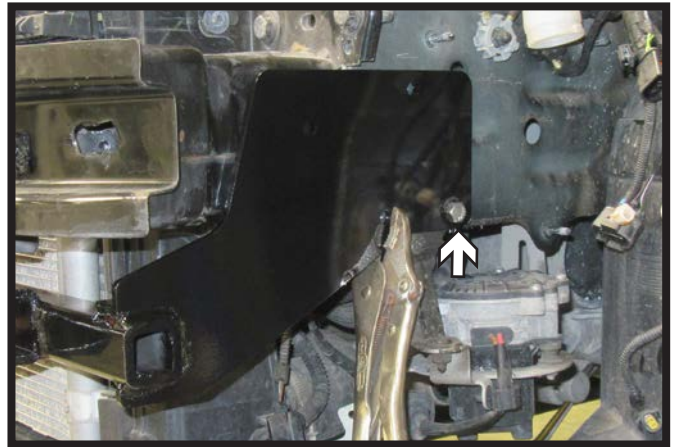
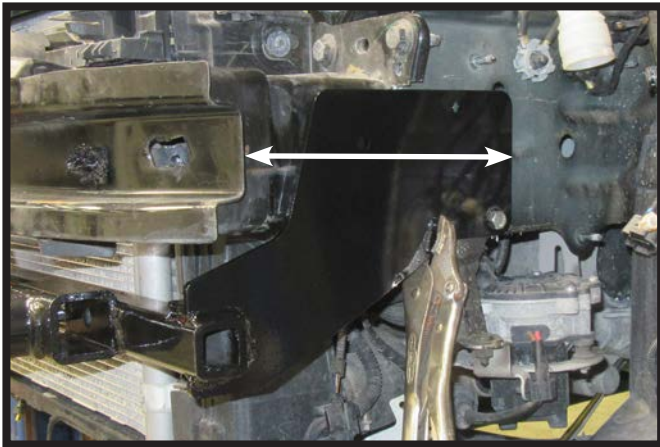

15. Position the baseplate on the vehicle so there is approximately 10-1/4" distance between the back of the baseplate and front of the bumper. Level and clamp the baseplate. Make sure that the baseplate is not hitting radiator lines or the ACC. Do this on both sides of the vehicle.

Using a 3/8" drill bit, drill the back bottom hole thru the frame and install the 3/8" hardware. Do this on both sides of the vehicle. Fully tighten all hardware.

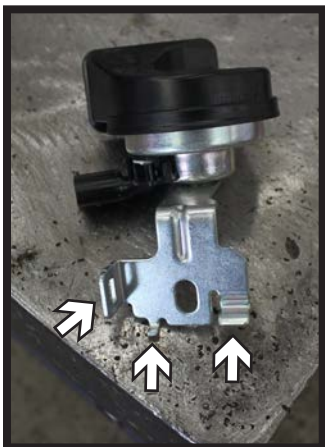

16. Prior to drilling and installing the remainder of the baseplate bolts, flatten the three (3) tabs of the horn brackets (left) so it will sit flat on the face of the side plate. Also it may be necessary to ream out the slot to accommodate the hardware (right).



17. Continue drilling the remaining baseplate holes thru the frame on each side of the vehicle. Install the 3/8" bolts into the top two (2) holes with lock washers and nut plates. Install 3/8" bolts into bottom two (2) holes with nylon lock nut on back side. Attach the horn assemblies to a lower rear hole. Fully tighten all hardware.

**\*\* Use Loctite® Red on all bolt threads and tighten all bolts to the appropriate torque.**

BX3839  
2015 Volkswagen Golf GTI (with ACC)  
Installation Instructions



18. **Optional:** If needed a couple spacer plates have been included. These can be slid down between the baseplate and the frame if there is a gap. Then tighten bolt fully.



19. Attach the permanent baseplate safety cables to the provided convenience link on the baseplate. The photo above shows the recommended installation of the cables to frame of vehicle. Additional options may interfere with suggested mounting; in this case, secure the cables to a solid piece of the frame as described in the General Information sheet. Be sure the safety cables do not rub against any hoses or moving parts. Do this on **BOTH** sides of the vehicle.

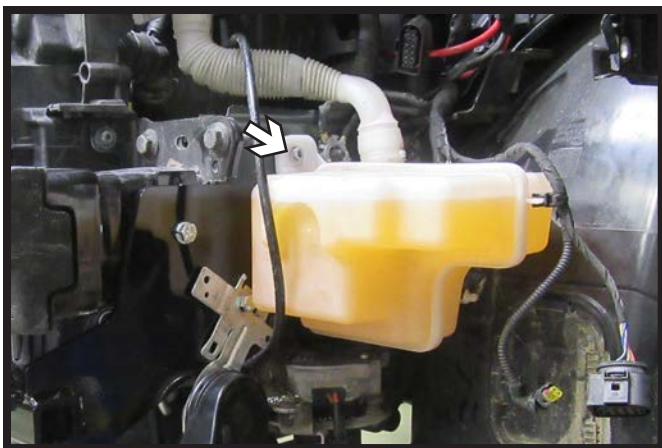

20. Reinstall the windshield washer fluid reservoir using four (4) flat washers on the top left stud in between the tank and the frame. This will space the tank so it clears the baseplate.



21. Reinstall the ACC, temperature sensor and styrofoam to bumper. Then reinstall the driver side head light.

BX3839  
2015 Volkswagen Golf GTI (with ACC)  
Installation Instructions

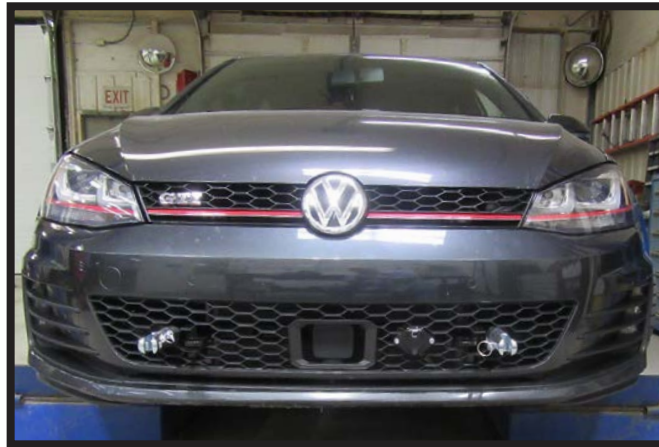

22. Before reinstalling the fascia unclip the plastic pieces on the back of the fascia and remove. These will not be reinstalled.

23. Hold the fascia as close to its original position, mark and trim the fascia around the convenience links and attachment tabs. Reinstall the fascia and grill.



# General Information

1. **It is the owner's responsibility to inspect all towing equipment for cracked welds, missing or worn parts and loose bolts before each towing trip.** Be sure to use Loctite® Red on all bolts and tighten to the recommended specifications.
2. **It is the owner's responsibility to hook up all towing equipment per manufacturer's instructions/ recommendations.**
3. Remove the attachment tabs when not in use (if applicable).

## Notice To Baseplate Installer

### 1. It is YOUR responsibility to watch for:

- Oil cooler and air conditioner lines
- Electrical wires and hoses
- Missing parts or attaching points on the frame

\*\* If the baseplate is improperly installed and is against a wire or hose, it could cause fluid leaks or electrical shorts some time after the actual baseplate installation.

## Permanent Baseplate Safety Cable Installation

Permanent baseplate safety cables are strongly recommended when towing a vehicle with a tow bar. The principle function of the permanent baseplate safety cables is to prevent the towed vehicle from breaking loose in the event the connection between the frame of the towed vehicle and the baseplate fails or becomes disconnected. The cables must be connected from the baseplate to the frame rail or cross member of the vehicle's frame. The illustrations below show the possible arrangements recommended by Blue Ox®. Each permanent baseplate safety cable must have an adequate weight rating for the towing system. The weight rating of the two (2) cables together will not qualify.

***Do not mount the permanent baseplate safety cables against wires, hoses or brake lines.***

These permanent baseplate safety cables should remain installed as long as the baseplate is installed on the vehicle. Permanent baseplate safety cables are to be used in conjunction with, and NOT a replacement for legally required safety cables attaching the towed vehicle to the towing vehicle.

### Option #1

(Baseplates with Convenience Link Tabs)

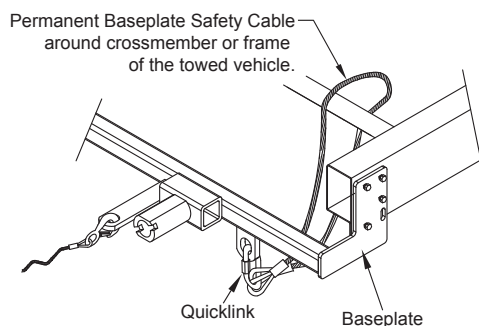

### Option #2

(Baseplates with out Convenience Link Tabs)

