



BX1977

2007-09 Chrysler Aspen 2007-09 Dodge Durango Installation Instructions

Please read BOTH these Installation Instructions and the General Towing Instructions before attempting to install or operate this equipment.

1. Blue Ox® towing products and accessories are intended to be installed by Blue Ox® Dealers who are familiar with our products and have the equipment and knowledge to do “fit work.”
2. Many Blue Ox® Baseplates are designed to use existing holes and hardware to mount the baseplate to the towed vehicle. Even though bolts are there, do not assume they are adequate for baseplate mounting. Always use hardware supplied in the hardware kit or existing hardware specified in the Baseplate Towing Installation Instructions.

Attachment Tab Height: 14 1/2”
Attachment Tab Width: 29”

Bolt Torque Specifications

Torque in Foot-Pounds per Metric Bolts

Bolt Size	Grade 8.8	Grade 10.9
6MM	6	8
8MM	16	22
10MM	31	40
12MM	54	70
14MM	89	117

Confirm the towability and pre-towing procedures for your vehicle with the owner’s manual or contact the vehicle’s manufacturer for specific towing procedures.

Bolt Torque Specifications

Torque in Foot-Pounds per Inch Bolts

Bolt Size	Grade 5	Grade 8
1/4”	10	14
5/16”	19	29
3/8”	33	47
7/16”	54	78
1/2”	78	119
5/8”	154	230



! WARNING

Failure to read and follow these instructions could result in separation of the towed vehicle from the tow bar, causing property damage, loss of towed vehicle, personal injury or death.

BX1977
 2007-09 Chrysler Aspen
 2007-09 Dodge Durango
 Installation Instructions

Parts List

Ref. No.	Qty.	Part #	Description
1	1	61-6382	Weldment, Baseplate, BX1977
2	6	61-4604	Weldment, 1/2" Nut Plate, w/10" Wire
3	6	201-0051	1/2-13 x 1 1/2" Hex Bolt, GRD. 5, ZP
4	6	203-0012	1/2" Lock Washer, ZP
5	2	201-0979	#12-14 x 1" Self Drilling Screw, ZP
6	2	201-0192	#10-32x1/2" Slot, Round Head Screw
7	2	203-0054	#10 Lock Washer
8	2	202-0047	#10-32 Hex Nut
9	2	101-5822	Adapter, 4 Way Connector
10	2	62-3469	Attachment, Assembly, SF/LB, 1 Hole
	2	290-0437	Cap Plug, Black (Not Shown)
	2	229-0512	Quicklink, 1/2", ZP (Not Shown)
	2	226-0049	Baseplate Safety Cable, 36" Class IV (Not Shown)

Tools Required

Loctite® RED
 10MM Socket
 18MM Socket
 17/32" Drill Bit
 Hack Saw Knife
 Vise Grips

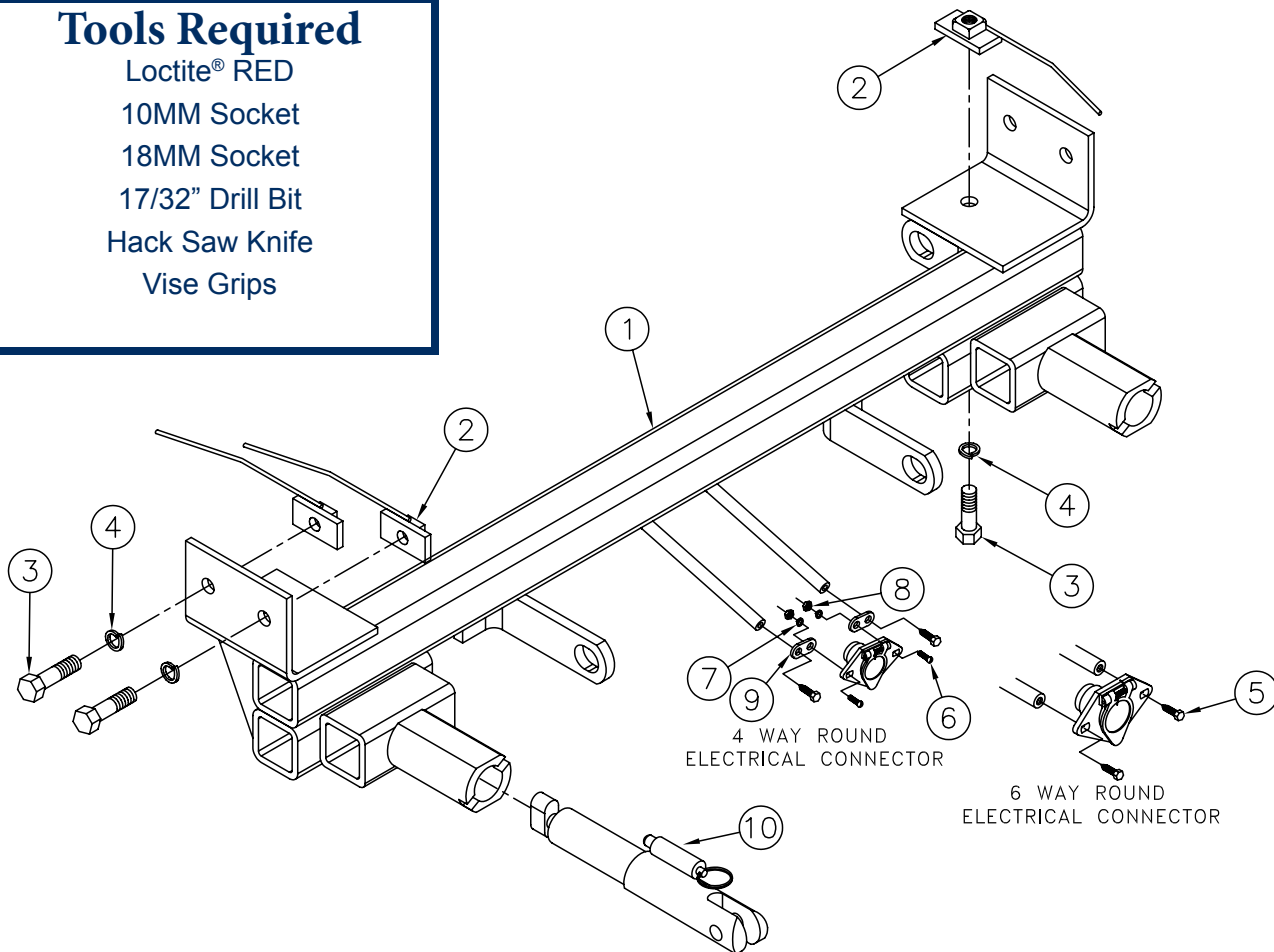

Important:

Use only genuine factory replacement parts on your baseplate. Do **NOT** substitute homemade or non-typical parts. If a bolt is lost or in need of replacement, for your safety and the preservation of your baseplate, be sure to use a replacement bolt of the same grade (In most cases it will be Grade 5, please reference the parts list above). Replacement parts may be ordered through your nearest Blue Ox® Dealer or Distributor.

BX1977
2007-09 Chrysler Aspen
2007-09 Dodge Durango
Installation Instructions

Vehicle Weight:

The weight of this vehicle is near the Class III, 5,000 lb. rating limitations. Some models, depending on options, may well exceed this 5,000 lb. rating. Be sure to confirm the weight of your individual vehicle before towing. As of 1999, the Aventa® II is now 10,000 lbs. and either the Aventa® II or the Aventa® LX tow bar must be used for these applications.

Tow Bar Adapters are NOT to be used with vehicles weighing over 5,000 lbs.

Installation Notes: The fascia and metal bumper are removed and reinstalled during installation of the baseplate. Drilling is required. Trimming of the fascia is required.

The dimensional variations between otherwise identical vehicles can be considerable. While the baseplate was designed for easy installation, it may be necessary to tailor the baseplate slightly to compensate for auto manufacturer's tolerances. These minor adjustments may include filing a hole slightly, bending electrical rods and/ or bending end plates.

The BX8869 Bulb and Socket Wiring Kit is recommended for this vehicle.



Installation Instructions:



1. Using a 10MM socket, remove three metric bolts just forward the front tire, on the wheel well. Once bolts are removed from the wheel well, pull plastic back and remove two metric bolts with a 10MM socket. Set bolts aside to be reinstalled later. Do this to both sides of the vehicle.



2. Using a 10MM socket, remove one metric bolt from the front of the fascia. Set bolt aside to be reinstalled later. Do this to both sides of the vehicle.

BX1977
2007-09 Chrysler Aspen
2007-09 Dodge Durango
Installation Instructions



3. Using a 10MM socket, remove one metric bolt located on the side of the opening in the fascia. Set bolt aside to be reinstalled later. Do this to both sides of the vehicle.



4. Using a 18MM socket, remove three metric nuts from the metal bumper. Set bumper and nuts aside to be reinstalled later. Do this to both sides of the vehicle. Some models may have a tow hook that will need to be removed, if applicable.



5. Lift baseplate straight up and slide forward up to dimple in frame. Baseplate should be straight and clamped into place with vise grips.



6. Using the baseplate as a template, drill two holes into the side of the frame and one hole in the bottom of the frame with a 17/32" drill bit. Place a piece of tubing over drill bit for protection while drilling out holes. Insert the 1/2" nut plates into the frame and align with drilled holes. Insert a 1/2-13X1 1/2" hex bolt and 1/2" lock washer into each hole and tighten down with a 3/4" socket. Do this to both sides of the vehicle.

BX1977
2007-09 Chrysler Aspen
2007-09 Dodge Durango
Installation Instructions

BE SURE TO USE LOCTITE® RED ON ALL BOLTS BEFORE TIGHTENING. TIGHTEN ALL BOLTS ACCORDING TO THE TORQUE CHART ON THE FRONT PAGE OF THESE INSTRUCTIONS OR ON PAGE 3 OF THE BASEPLATE TOWING GENERAL INSTRUCTIONS.



7. Attach permanent baseplate safety cables to the convenience link on the baseplate. The photo above shows recommended installation of the cables to frame of vehicle. If vehicle has additional options (not shown above) which interfere with mounting permanent baseplate safety cables, secure the cables to a solid piece of the vehicle frame as described in instructions included with the permanent baseplate safety cables.

8. Reinstall metal bumper, by just barely starting the two outside nuts (leaving them really loose) and then tip bumper out towards the front to start the back nut. You will then be able to tighten down all three nuts.



9. Using a hack saw knife, mark and trim out opening in the fascia for the attachment tabs, using the photos above as a template. Do this to both sides of the vehicle. Models that have tow hooks will not need to cut out opening in fascia.

BX1977
2007-09 Chrysler Aspen
2007-09 Dodge Durango
Installation Instructions

Be sure that **ALL** electrical connections are plugged in properly and functioning **BEFORE** installing the fascia.



Install the tow bar and safety cables according to the instructions provided in their packages. When demonstrating this to the customer, be sure to include all the contents and packages.

Do **NOT** substitute other devices if the tow bar pins and clips are misplaced.

DEALER or INSTALLER:
Be certain the user receives the instruction sheets for their products.



General Information

1. It is the owner's responsibility to inspect all towing equipment for cracked welds, missing or worn parts and loose bolts before each towing trip. Be sure to use Loctite® Red on all bolts and tighten to the recommended specifications.
2. It is the owner's responsibility to hook up all towing equipment per manufacturer's instructions/ recommendations.
3. Remove the attachment tabs when not in use (if applicable).

Notice To Baseplate Installer

1. It is YOUR responsibility to watch for:

- Oil cooler and air conditioner lines
- Electrical wires and hoses
- Missing parts or attaching points on the frame

** If the baseplate is improperly installed and is against a wire or hose, it could cause fluid leaks or electrical shorts some time after the actual baseplate installation.

Permanent Baseplate Safety Cable Installation

Permanent baseplate safety cables are strongly recommended when towing a vehicle with a tow bar. The principle function of the permanent baseplate safety cables is to prevent the towed vehicle from breaking loose in the event the connection between the frame of the towed vehicle and the baseplate fails or becomes disconnected. The cables must be connected from the baseplate to the frame rail or cross member of the vehicle's frame. The illustrations below show the possible arrangements recommended by Blue Ox®. Each permanent baseplate safety cable must have an adequate weight rating for the towing system. The weight rating of the two (2) cables together will not qualify.

Do not mount the permanent baseplate safety cables against wires, hoses or brake lines.

These permanent baseplate safety cables should remain installed as long as the baseplate is installed on the vehicle. Permanent baseplate safety cables are to be used in conjunction with, and NOT a replacement for legally required safety cables attaching the towed vehicle to the towing vehicle.

OPTION #1

Permanent Baseplate Safety Cables to Cross Member or Frame of Towed Vehicle.

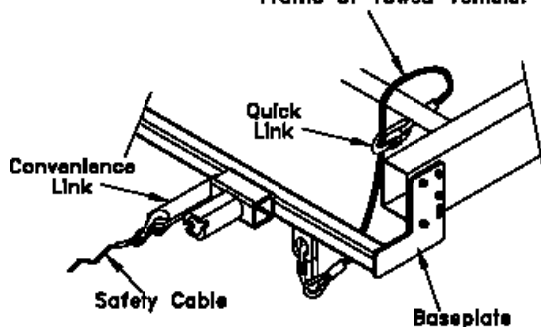

OPTION #2

Permanent Baseplate Safety Cables to Cross Member or Frame of Towed Vehicle.

