



Installation Instructions

HighRock 4x4™ Front Bumper

Vehicle Application: 2007 Jeep® Wrangler and Wrangler Unlimited

•HighRock 4x4™ Front Bumper

Part Number: 42918 / 44918



•HighRock 4x4™ Approach Roller™







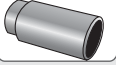

Part Number: 42905 (Sold Separately)

•HighRock 4x4™ Tubular Grill Guard

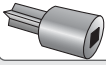
Part Number: 42915 /

44915 (Sold Separately)

| INSTALLATION TIME | SKILL LEVEL |
|---|--|
|  <p>1-1/2 Hours</p> |  <p>3 - Moderately Difficult</p> |

| TOOLS | | | |
|--|---|---|--|
| <p>Socket</p>  <p>15mm, 18mm, 3/8" and 1/2"</p> | <p>Ratchet</p>  | <p>Torx Socket</p>  <p>T55</p> | <p>Wrench</p>  <p>18mm and 3/8"</p> |
| <p>Allen Wrench</p>  <p>3/16" and 6mm</p> | <p>Phillips Screwdriver</p>  | <p>Flat-Head Screwdriver</p>  | <p>Pliers</p>  |
| <p>Safety Glasses</p>  | | | |



! WARNING Do not use Front Bumper to tow vehicle.

! WARNING This product is designed primarily to enhance the appearance of the vehicle. Do not rely in any way on the components of this product to protect against injury or death in the event of an accident. Never operate the vehicle in excess of manufacturer's specifications.

WEAR SEAT BELTS AT ALL TIMES

Read and follow, precisely, all installation instructions provided when installing product. Failure to do so may result in a poor fit and could place occupants of the vehicle in a potentially dangerous situation.

HighRock 4x4™ Front Bumper Installation Instructions

Parts List and Hardware Identification

42918 HighRock 4x4™ Front Bumper

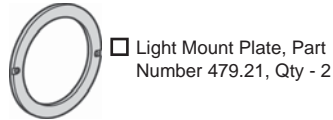
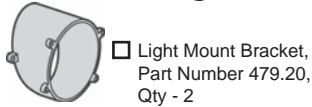
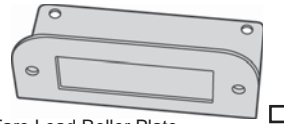
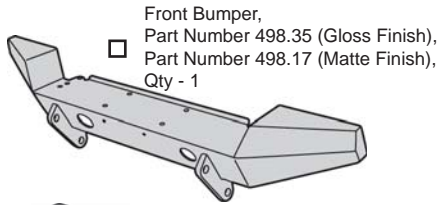

Hardware Kit Part # 485.73

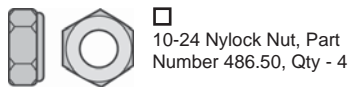
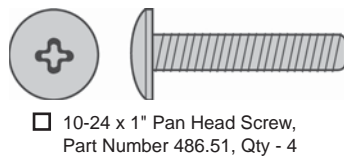
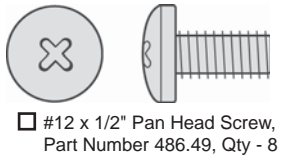

42915 HighRock 4x4™ Tubular Grill Guard – Sold Separately

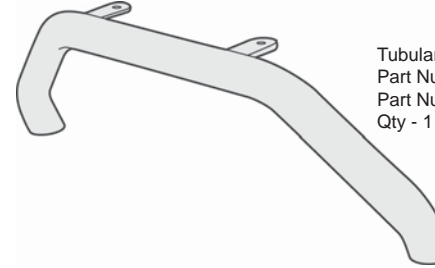

Hardware Kit Part # 498.36

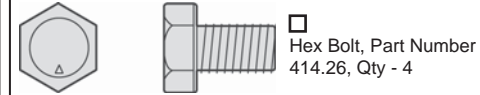

42905 HighRock 4x4™ Approach Roller™ – Sold Separately

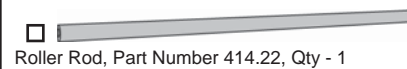
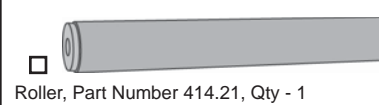

Hardware Kit Part # 498.37

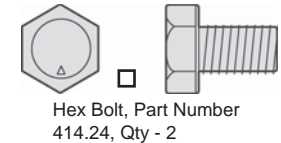

HighRock 4x4™ Front Bumper Installation Instructions

NOTE If you intend to install a fare lead roller and/or a winch on your bumper, you will need to install them on the bumper before you install the bumper on the vehicle.

If you decide at a later date to install a fare lead roller or winch on your vehicle, it will be easiest to remove the bumper from the vehicle before installing.

If you wish to install a winch without a fare lead roller, skip step 3.

If you do not wish to install a fare lead roller or winch at this time, skip steps 3 and 4.

1 Remove the Plastic Skid Plate

Use a flat screwdriver or pliers to pry out the four (4) fasteners that secure the edge of the skid plate. Then use a phillips screwdriver to remove the push fasteners that secure the brackets on the skid plate to the frame.

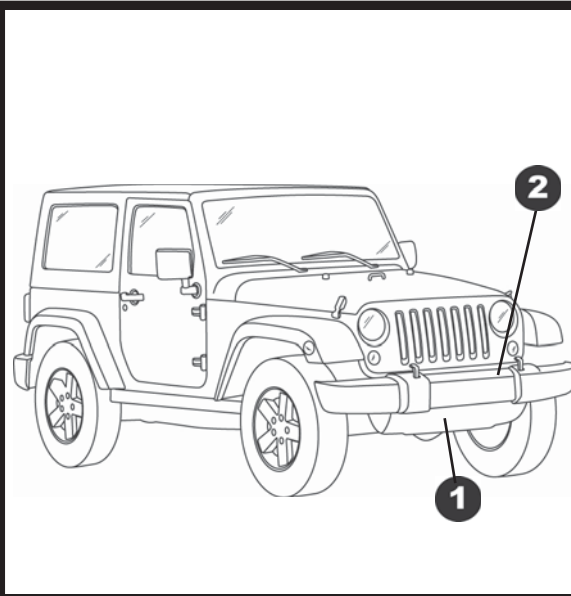
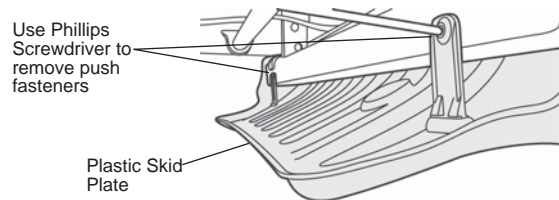
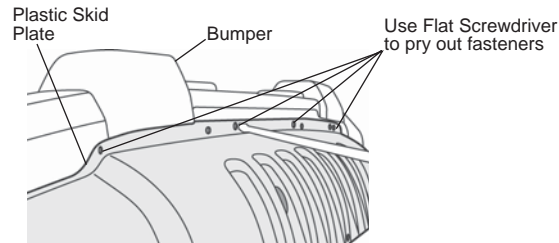

3 Install Fare Lead Roller on Fare Lead Plate

If you have a Fare Lead Roller, use the mounting hardware provided with the roller to install it on the Fare Lead Plate.

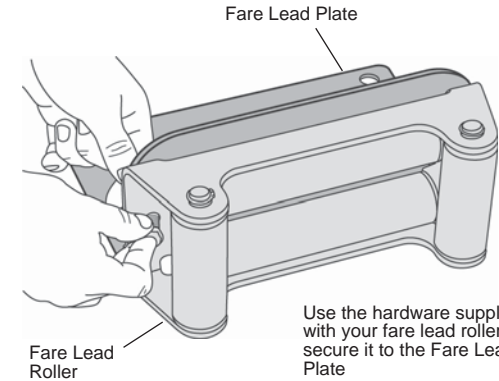

CAUTION If you have a Jeep® Rubicon with Factory Fog Lights, you must disconnect them before removing the bumper.

2 Remove the Original Bumper

Use a socket wrench to remove the four (4) nuts on each side of the bumper that secure the bumper to the frame. Access these nuts from behind the bumper.

Slide the bumper off the studs.

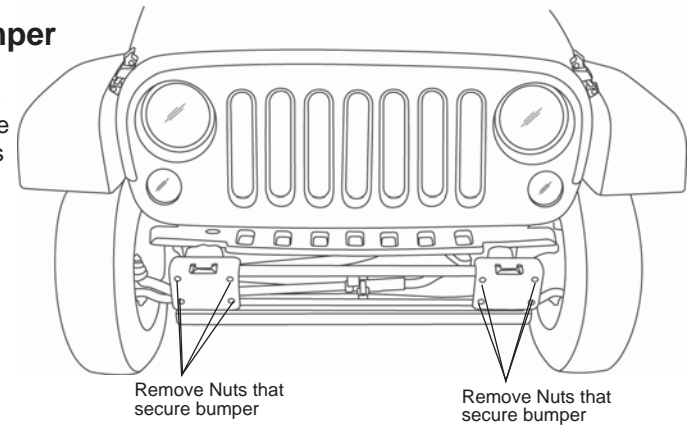

HighRock 4x4™ Front Bumper Installation Instructions

4 Install Light Mount Brackets on Lights

Remove the lights from the original bumper. Set the screws aside to be re-used.

Orient the light with the adjustment screw facing down. Use four (4) #12 x 1/2" Pan Head Screws to secure the light to the Light Mount Bracket. Repeat with both lights.

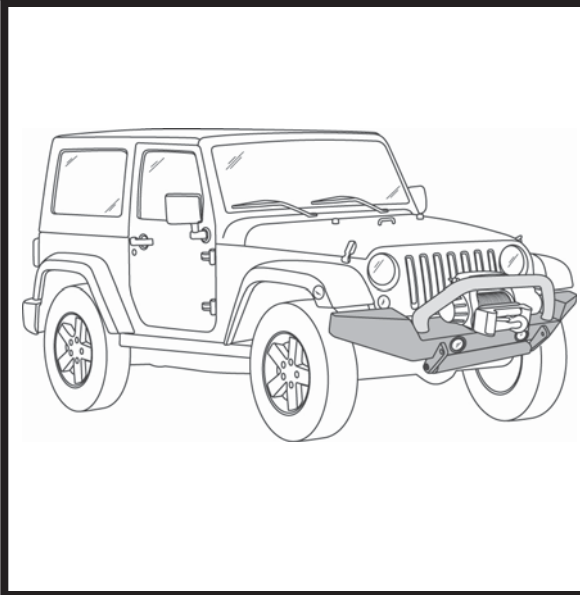
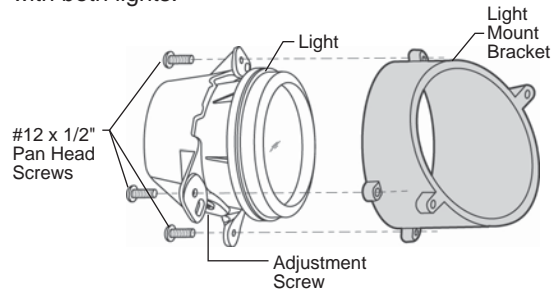

NOTE If you intend to install a winch only, you may install it directly on your bumper and do not need to use the Fare Lead Plate.

6 Install Fare Lead Plate and/or Winch on Bumper

Place the Front Bumper on a flat surface. Place the Fare Lead Plate assembly on the bumper and align the mounting holes. Place the winch on top of the plate and use the hardware provided with the winch to secure it to the bumper.

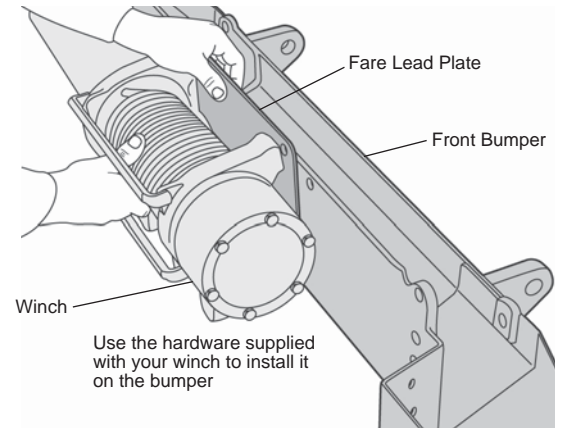

5 Install Lights on Bumper

Use the 10-24 Pan Head Screws and 10-24 Nylock Nuts to secure the Light Assemblies to the Bumper. Mount the assemblies from behind the Bumper to the Light Mount Plates on the front.

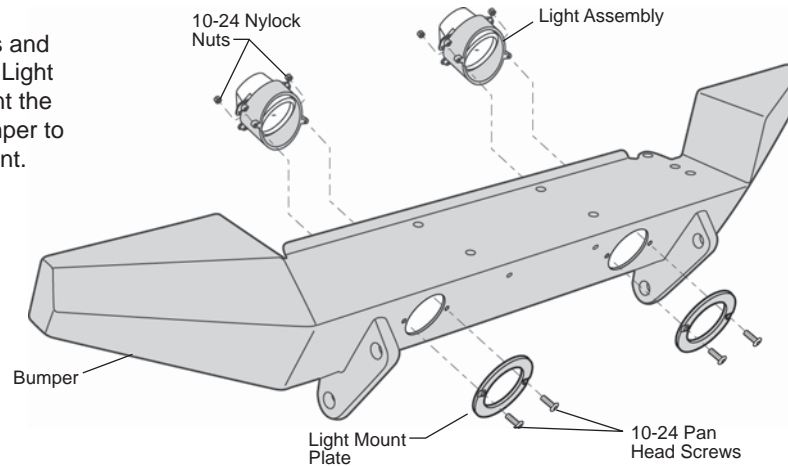

HighRock 4x4™ Front Bumper Installation Instructions

7 Install 42915 HighRock 4x4™ Tubular Grill Guard – Sold Separately

Place the Tubular Grill Guard on the Front Bumper so that the holes in the guard line up with the holes in the bumper. Use two (2) Hex Bolts, Washers, Lock Washers and Lock Nuts to secure each side of the Tubular Grill Guard.

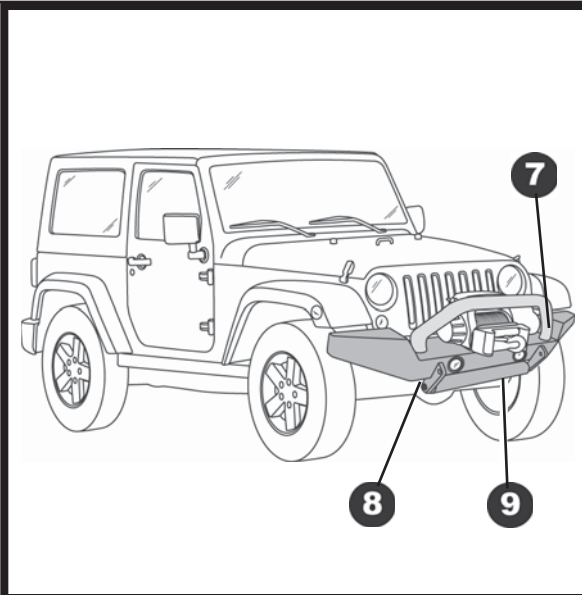
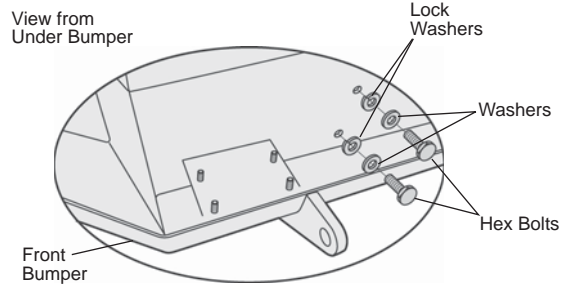
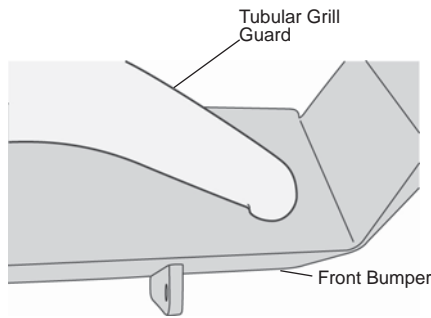

9 Install 42905 HighRock 4x4™ Approach Roller™ – Sold Separately

Place the Roller between the flanges on the Front Bumper and align the holes in the Roller with the holes in the flange. Slide the Rod through the flanges and the Roller. Install a Hex Bolt and a Washer in each end of the Rod to secure it to the flanges.

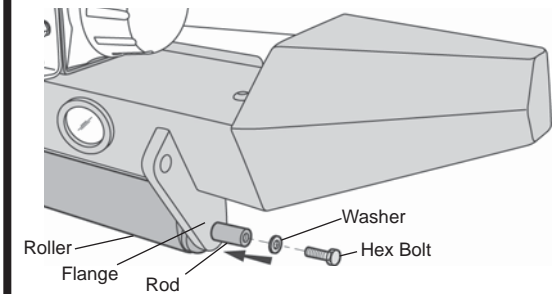

CAUTION Two or more people are required to lift the bumper safely.

8 Install Bumper Assembly

Lift the Front Bumper Assembly onto the front frame rails on the vehicle. Slide the studs in the Bumper through the holes in the frame and install an M10 Washer and M10 Nylock Nut on each stud.

