

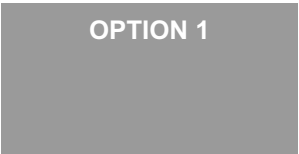

TP4463

FLAT PANEL TV MOUNTING SYSTEM

TRIPLE PLAY™

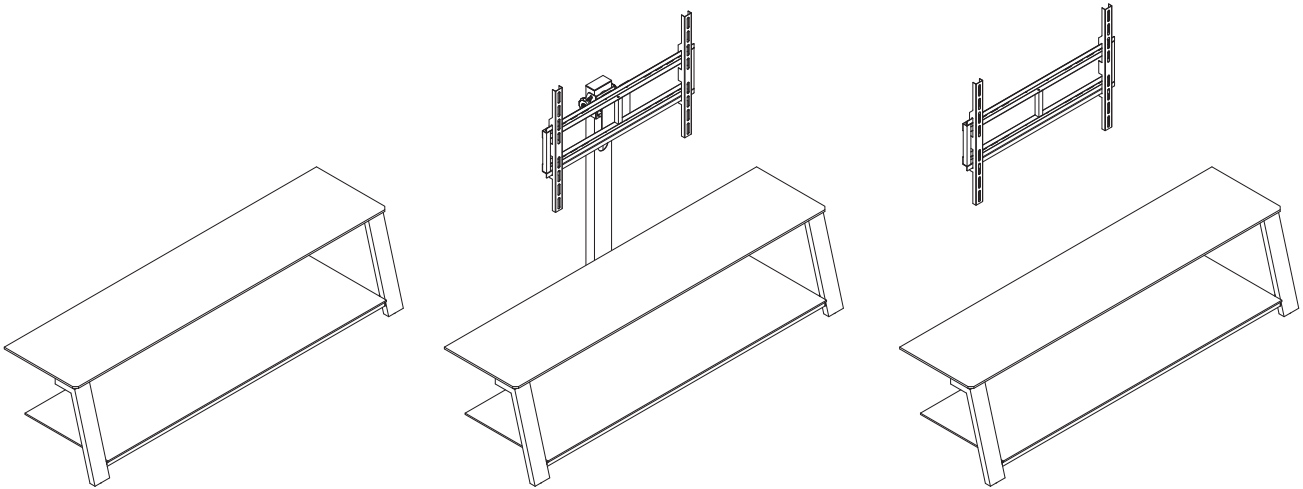

OPTION 1

Flat Panel TV Stand

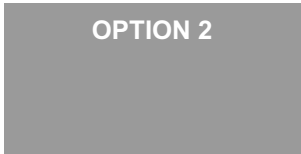

OPTION 2

Stand with TV Mounting System

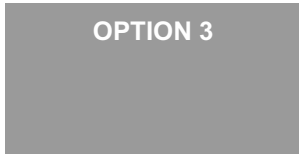

OPTION 3

Stand with Wall Mount











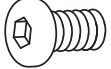
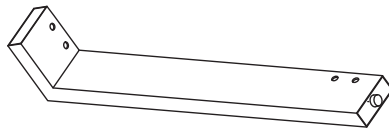
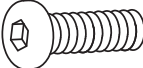
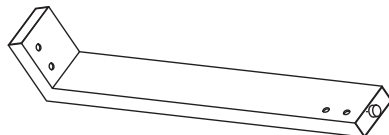
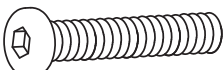

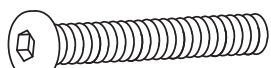
ASSEMBLY INSTRUCTIONS

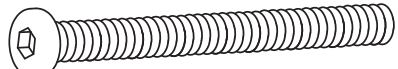
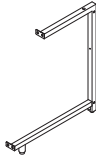

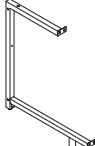
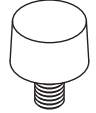
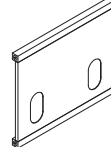
FOR YOUR SAFETY, PLEASE FOLLOW THESE PRECAUTIONS:

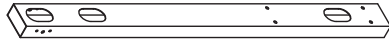

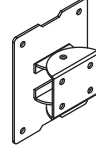
- ! DO NOT PLACE ITEMS ON THE SHELVES (OR TV MOUNT) WHICH EXCEED THE MAXIMUM WEIGHT LIMITS OF 125 LBS. FOR THE TV, AND 75 LBS. FOR BOTTOM SHELF.**
- ! ONLY WALL MOUNT INTO WOOD STUDS OR CONCRETE WALLS. DO NOT ATTEMPT TO WALL MOUNT THE TELEVISION INTO DRYWALL ONLY.**
- ! THE MAXIMUM WEIGHT OF YOUR TELEVISION CANNOT EXCEED THE MAXIMUM WEIGHT RATING OF THE WALL MOUNT.**
- ! ALWAYS REMOVE THE TV AND OTHER EQUIPMENT FROM THE FURNITURE PRIOR TO MOVING THE ASSEMBLED UNIT.**
- ! WHEN IN USE, THIS FURNITURE MUST BE PLACED ON A FLAT, SOLID AND LEVEL SURFACE.**
- ! DO NOT LEAN ON THE TV WHEN IT IS ON THE TV STAND.**
- ! DO NOT CLIMB OR STEP ON THE STAND.**
- ! DO NOT BANG INTO OR PLACE YOUR OWN WEIGHT ON ANY OF THE SHELVES.**
- ! THIS PRODUCT WAS DESIGNED TO BE INSTALLED AND UTILIZED ONLY AS SPECIFIED IN THIS MANUAL. BELL'O INTERNATIONAL CORPORATION WILL NOT BE RESPONSIBLE FOR FAILURE TO ASSEMBLE AS DIRECTED OR FOR THE IMPROPER ASSEMBLY, USE, OR HANDLING OF THIS PRODUCT.**
- ! IMPROPER INSTALLATION OF THIS PRODUCT MAY CAUSE DAMAGE OR SERIOUS INJURY. BELL'O INTERNATIONAL CORPORATION CANNOT BE LIABLE FOR DIRECT OR INDIRECT DAMAGE OR INJURY CAUSED BY INCORRECT MOUNTING, INCORRECT USE, OR INCORRECT ASSEMBLY.**
- ! IF THE MOUNTING BRACKET WILL BE ATTACHED TO ANY STRUCTURE OTHER THAN SPECIFIED IN THIS MANUAL, ONLY A LICENSED PROFESSIONAL CONTRACTOR/INSTALLER SHOULD PERFORM THIS INSTALLATION. THE SUPPORTING STRUCTURE MUST SUPPORT, AT MINIMUM, FOUR TIMES THE COMBINED WEIGHT OF THE MOUNTING BRACKET AND TV. IT IS THE RESPONSIBILITY AND LIABILITY OF THE INSTALLER TO ENSURE THE SUITABILITY OF THE SUPPORTING STRUCTURE.**
- ! THE MOUNT WITH THE INCLUDED HARDWARE IS NOT UL LISTED FOR INSTALLATION INTO METAL STUDS. FOR THE AVAILABILITY OF UL LISTED METAL STUD MOUNTING HARDWARE, MONITOR WEIGHT LIMIT AND INSTALLATION INSTRUCTIONS PLEASE CHECK WITH YOUR RETAILER OR AN INSTALLATION PROFESSIONAL.**



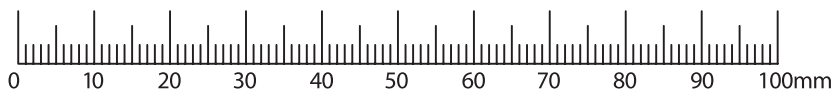

PARTS LIST

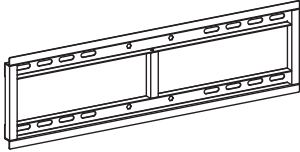
#	Part	Quantity	#	Part	Quantity
YF1	 12 mm	16	YF11		1
YF2	 18 mm	4	YF12		1
YF3	 28 mm	2	YF13-3		1
YF4	 35 mm	4	YF14-3		1
YF5	 54 mm	4	YF15-3		1
YF6	 25 mm	2	YF16-3		1
YF7		4	YF17-3		1
YF8		6	YF18		1
YF9		4	YF19		1
YF10		2	YF20		1

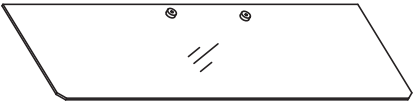





PARTS LIST

#	Part	Quantity
YF21		1
YF22		2
YF23-3		1
YF24-3		1

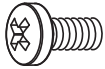
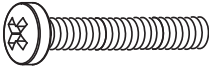
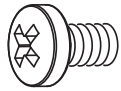
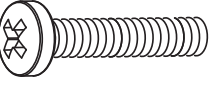
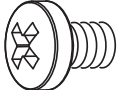
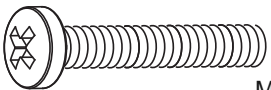
#	Part	Quantity
YF25		4
YF26		4
YF27		1
YF28		1

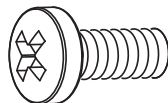
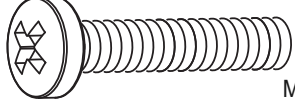
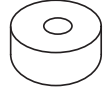
TV MOUNTING SCREWS

#	Part	Quantity
TVY1	 M4 x 12 mm	4
TVY2	 M4 x 28 mm	4
TVY3	 M5 x 12 mm	4
TVY4	 M5 x 28 mm	4
TVY5	 M6 x 14 mm	4
TVY6	 M6 x 35 mm	4

#	Part	Quantity
TVY7	 M8 x 18 mm	4
TVY8	 M8 x 40 mm	4
TVY9	 Short Spacer	4
TVY10	 Long Spacer	4
TVY11	 M4/M5 19mm Washer	4
TVY12	 M6/M8 19mm Washer	4

OPTION 1: FLAT PANEL TV STAND

NOTE: 2 PEOPLE ARE RECOMMENDED TO ASSEMBLE THIS FURNITURE. TO AVOID DAMAGE DURING ASSEMBLY, IT SHOULD BE ASSEMBLED ON A SOFT SURFACE.

Fig. 1-1

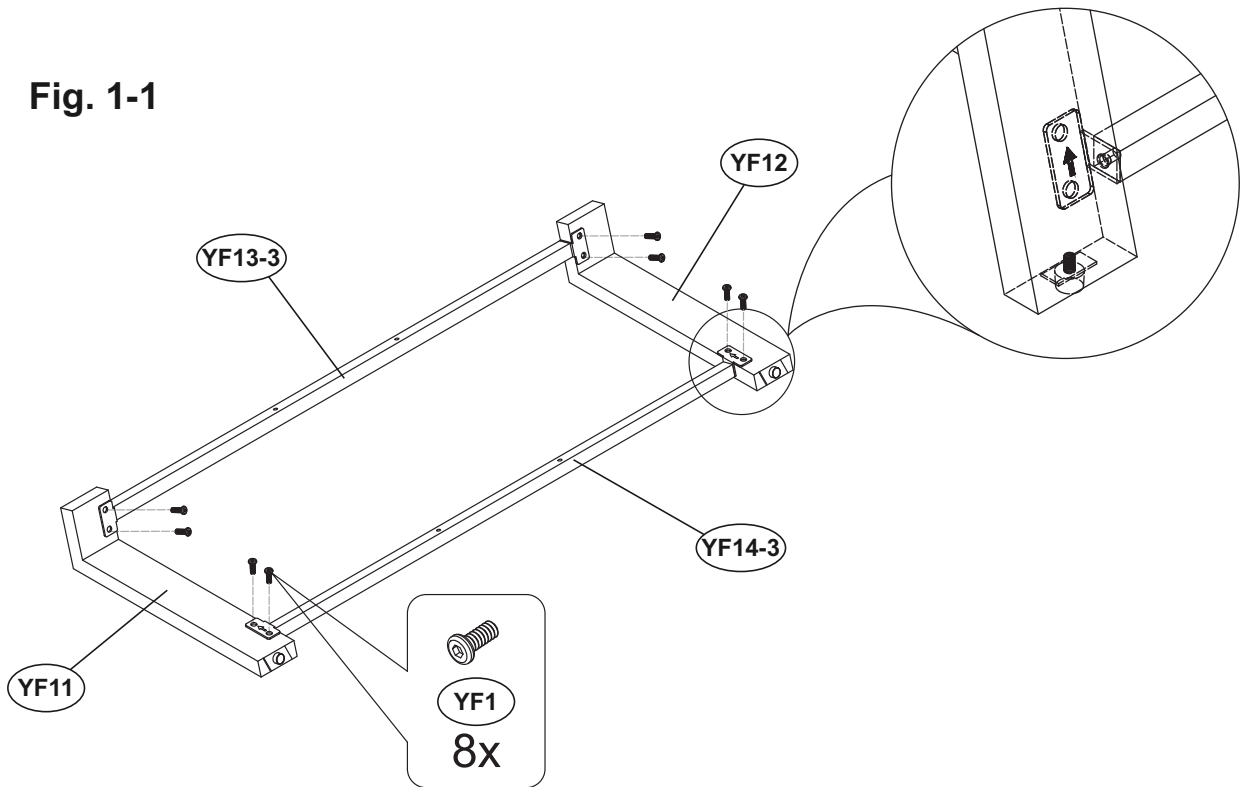

- 1-1. On a soft, flat surface, **ATTACH** the Top Crossbar (YF13-3) to the Right and Left Legs (YF11, YF12) using four 12 mm Screws (YF1) exactly as shown above. **Do not yet fully tighten.**
- 1-2. **ATTACH** the Bottom Crossbar (YF14-3) to the Left and Right Legs (YF11, YF12) using four 12 mm Screws (YF1) as shown.
- 1-3. Make sure all parts are correctly attached and are laying flat on a level surface, then **FULLY TIGHTEN** all eight 12 mm Screws (YF1).

Fig. 1-2

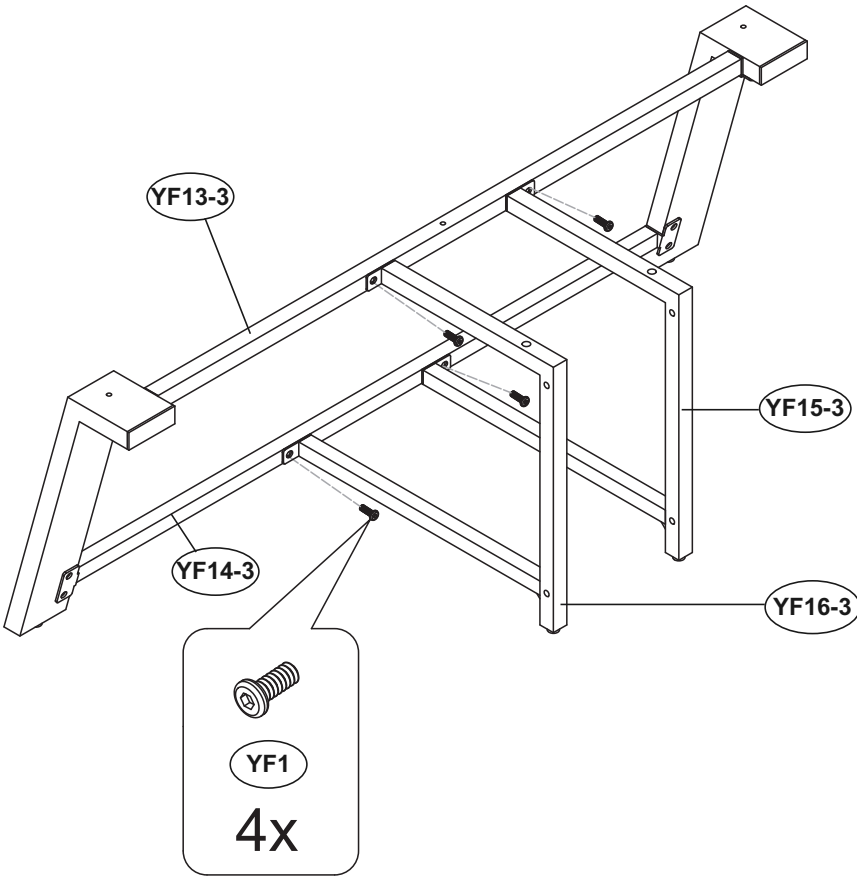

1-4. **LIFT** the front frame upright, and **ATTACH** the Left and Right Rear Support Frames (YF15-3, YF16-3) using four 12 mm Screws (YF1) as shown above. **Fully tighten all Screws.**

Fig. 1-3

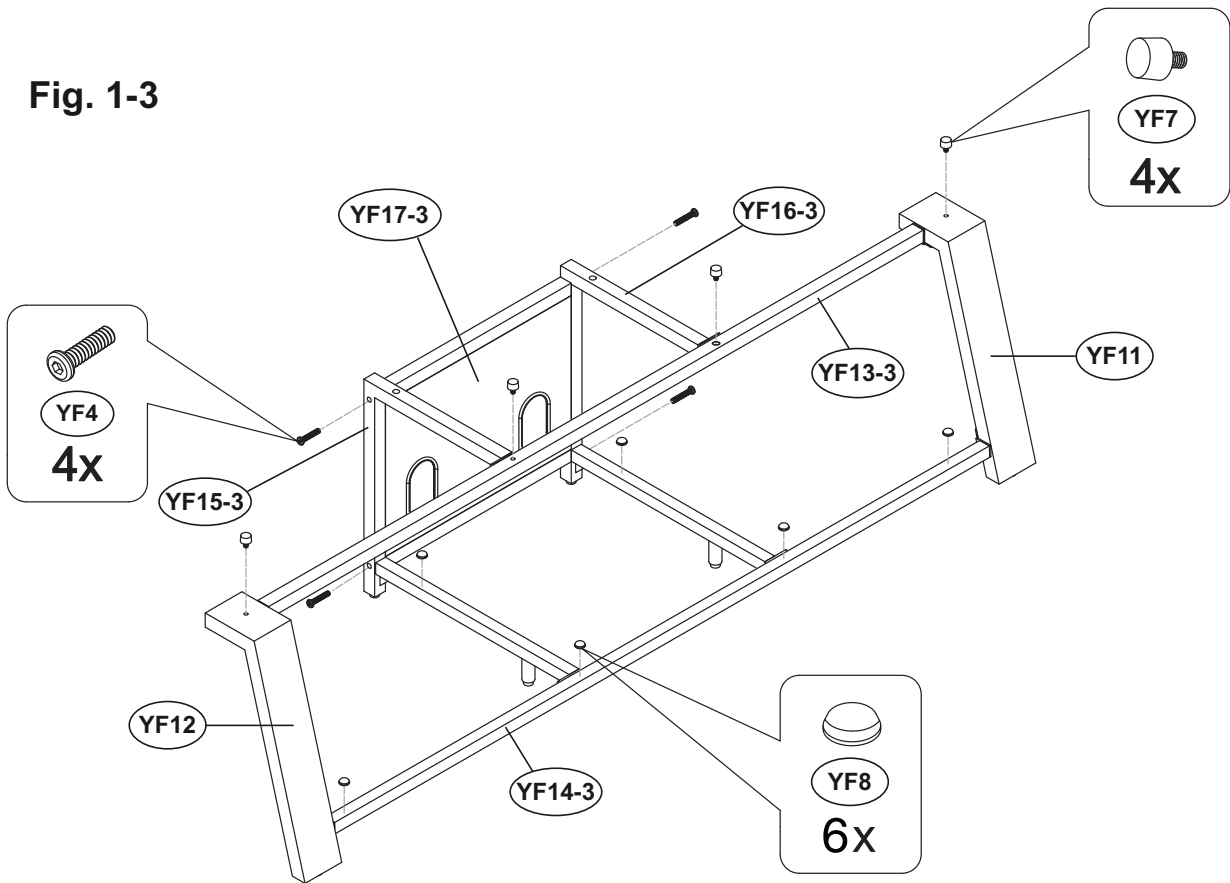

- 1-5. **ATTACH** the CMS® (Cable Management System) Panel (YF17-3) to the Left and Right Rear Support Frames (YF15-3, YF16-3) using four 35 mm Screws (YF4) as shown above. **Tighten Screws fully.**
- 1-6. **SCREW** four Adjustable Glass Pads (YF7) into the threaded holes at the tops of the Top Crossbar (YF13-3) and Right and Left Legs (YF11, YF12).
NOTE: When the Top Glass Shelf is installed later, you can TURN these Adjustable Glass Pads to ensure level support for the Top Shelf.
- 1-7. **APPLY** six Soft Glass Pads (YF8), evenly distributed, along the Bottom Crossbar (YF14-3) and Left and Right Rear Support Frames (YF15-3, YF16-3) as shown.

Fig. 1-4

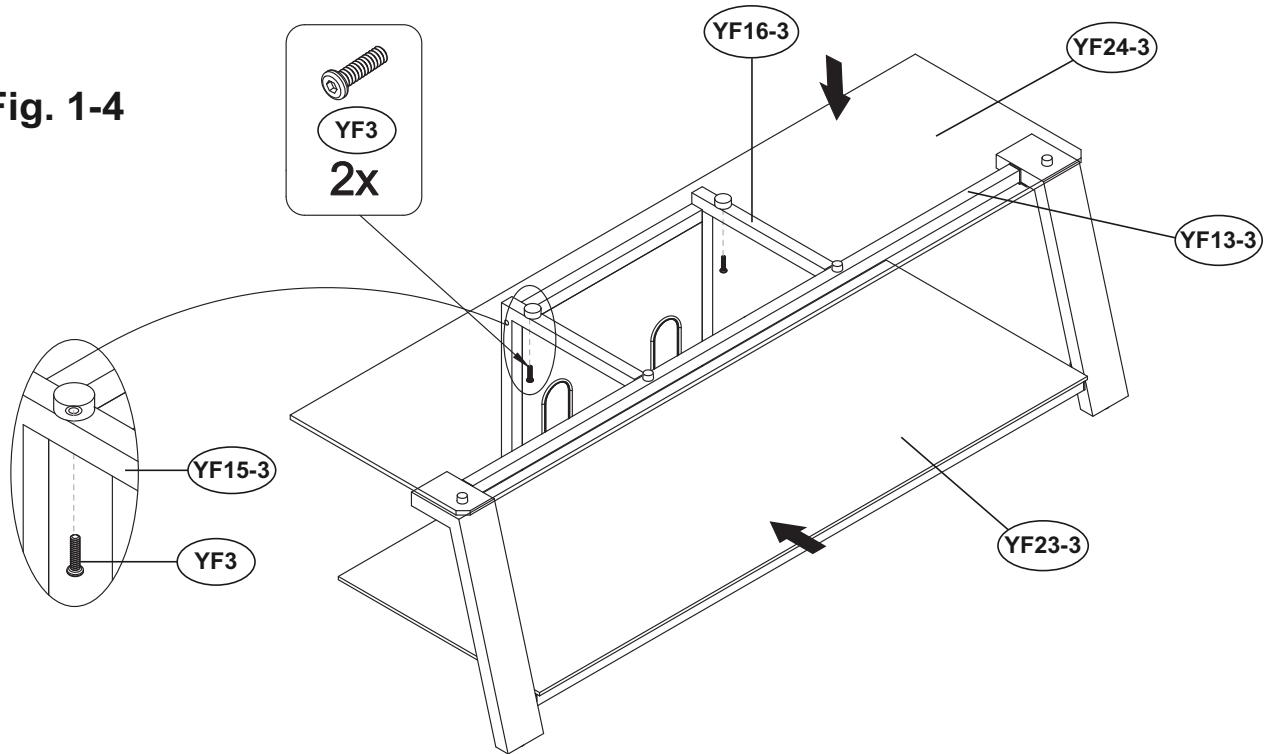

- 1-8. From the front, carefully **PLACE** the Lower Glass Shelf (YF23-3) down onto the Soft Glass Pads (YF8) along the Bottom Crossbar (YF14-3) and the Right and Left Rear Support Frames (YF15-3, YF16-3). Make sure the Glass Shelf is well supported, level, and properly in place.
- 1-9. Carefully **PLACE** the Top Glass Shelf (YF24-3) down onto the Top Crossbar (YF13-3) and Right and Left Rear Support Frames (YF15-3, YF16-3). Make sure the silver discs on the underside of the Top Glass Shelf are properly inserted into the holes at the top of the Right and Left Rear Support Frames. **SECURE** the Top Glass Shelf using two 28 mm Screws (YF3) from underneath as shown above. **Be careful not to overtighten!**

Adjust the Adjustable Glass Pads (YF7) if necessary to properly support the Top Shelf (YF24-3). Always make sure the TV stand and all glass shelves are level and well supported before attempting to place any components on them.

OPTION 2: FLAT PANEL TV MOUNTING SYSTEM

Fig. 2-1

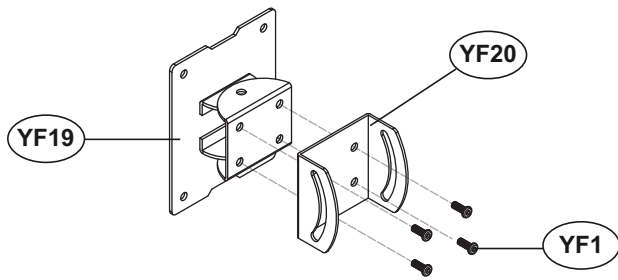
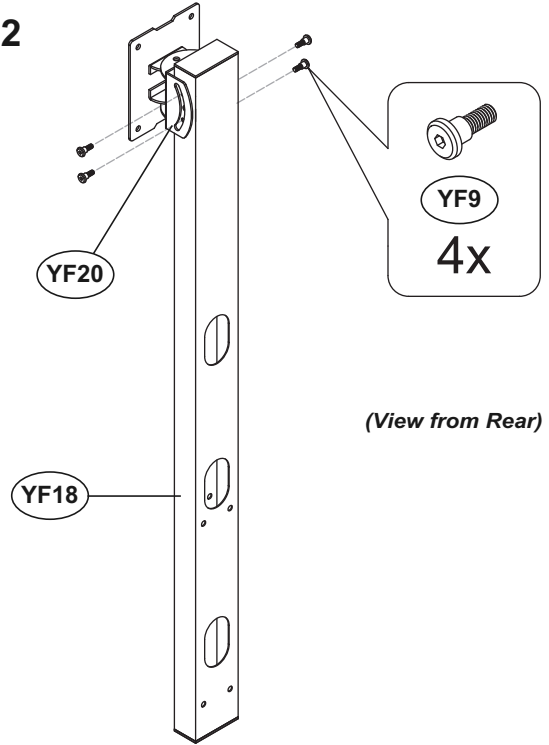

Fig. 2-2



2-1. **ATTACH** the Tilt Bracket (YF20) to the Swivel Bracket (YF19) using four 12 mm Screws (YF1) as shown. **Tighten Screws fully.**

2-2. **ATTACH** the Tilt Bracket (YF20) to the Mounting Pole (YF18) as shown and **SECURE** using four Guide Screws (YF9). **Tighten Guide Screws fully.**

Fig. 2-3

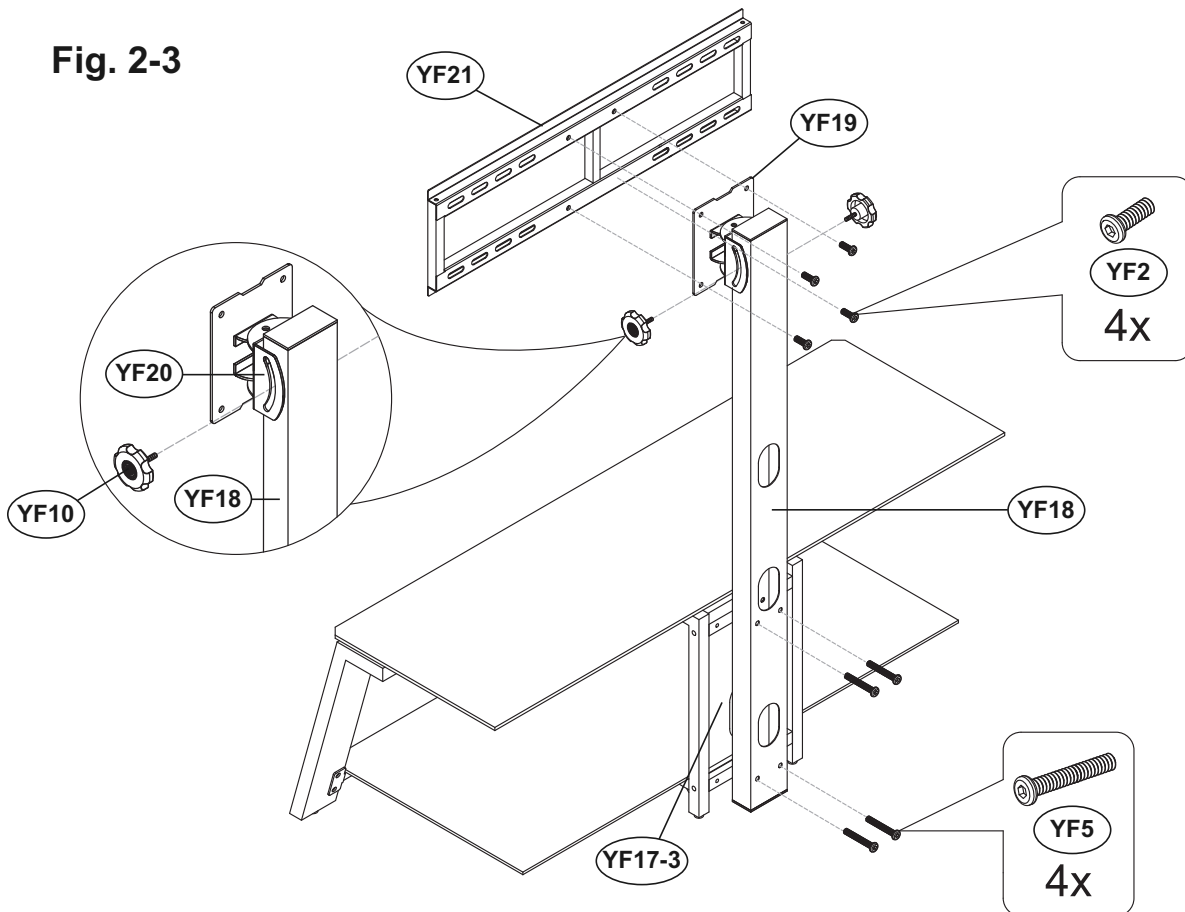

2-3. **ATTACH** the Mounting Pole (YF18) to the back of the CMS® Panel (YF17-3) using four 54 mm Bolts (YF5) as shown. **Tighten Bolts fully.**

2-4. **SCREW** in two Tilt Adjustment Knobs (YF10) through the slots in the Tilt Bracket (YF20) and into the threaded hole in the Mounting Pole (YF18) as shown. Make sure the Tilt Bracket is in a level and upright position, then **fully tighten** both Tilt Adjustment Knobs by hand.

NOTE: The tilt of the TV can be adjusted later by slightly loosening these Knobs, adjusting the tilt, then tightening them again.

2-5. **ATTACH** the Mounting Bracket (YF21) to the Swivel Bracket (YF19) using four 18 mm Screws (YF2) as shown. **Tighten Screws fully.**

MOUNTING THE TELEVISION / POSE DU TÉLÉVISEUR

CAUTION: CAREFULLY DETERMINE THE CORRECT MOUNTING PROCEDURE TO PREVENT DAMAGE TO YOUR TV AND/OR BELL'O® MOUNTING SYSTEM. ALWAYS REMOVE THE TELEVISION & COMPONENTS BEFORE ATTEMPTING TO MOVE THE STAND.

2-6. **SELECT THE CORRECT SCREW.** Before beginning, test several of the Screws in your Hardware Kit to find the correct size and length for your television.

NOTE (!): Use Spacers if Monitor Arms (YF22) do not fit firmly against the back of the television, such as when the back of the television is curved, contains larger recessed mounting holes, or some other obstruction is in the way. Spacers also provide extra room for cables. The Arms must rest securely on the spacers, and should not be loose.

Fig. 2-4

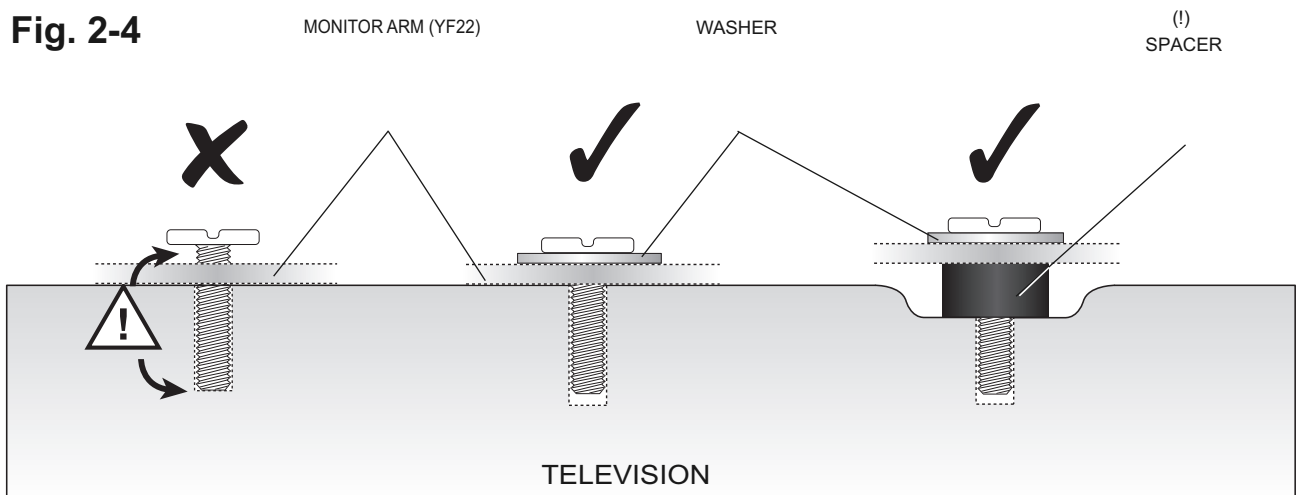
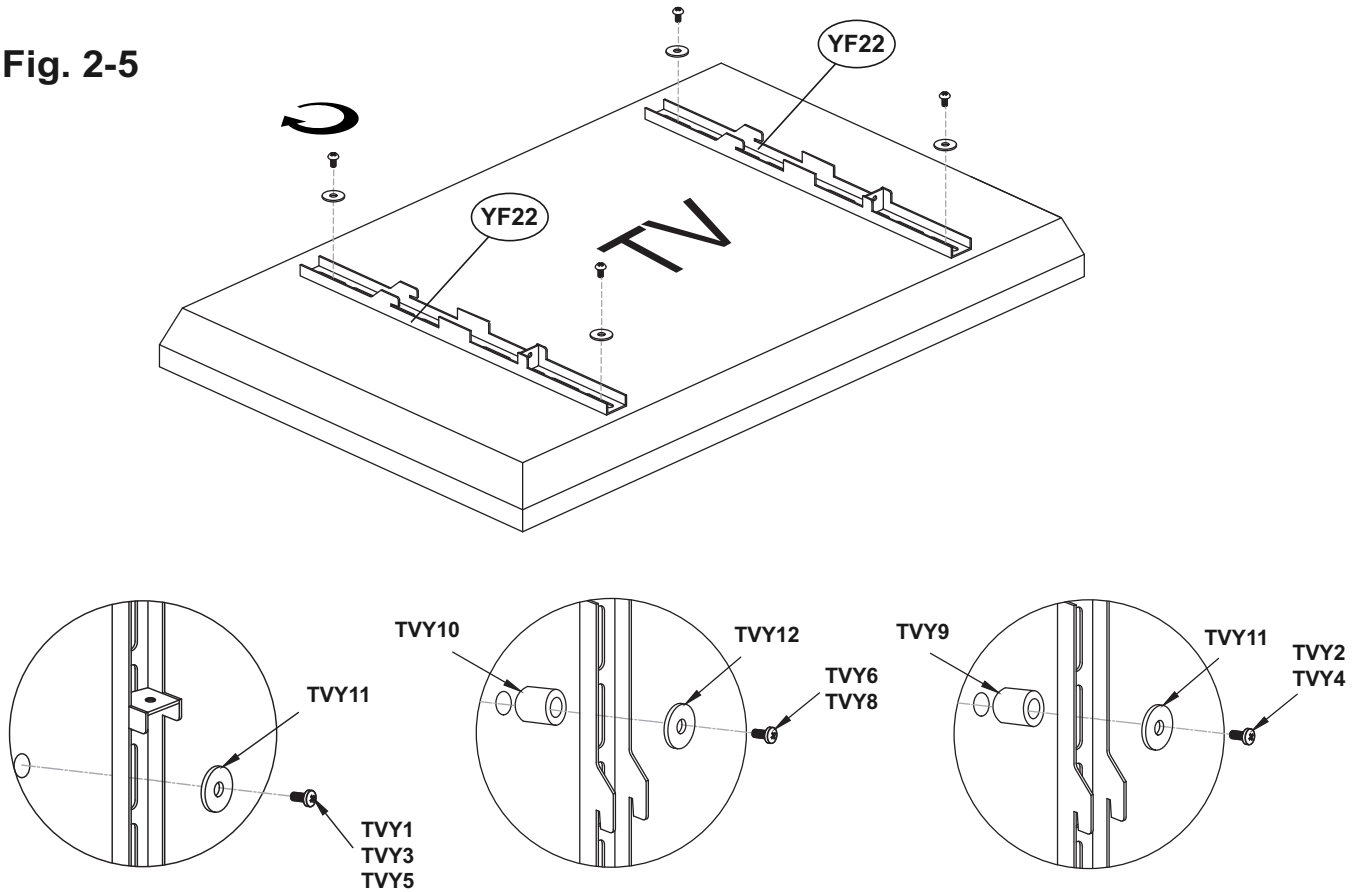

Fig. 2-5



2-7. **PLACE** your TV face-down on a flat, very soft, non-abrasive surface, taking extreme caution to not damage the face of your TV.

2-8. **ATTACH** each Monitor Arm (YF22) to the back of your television as shown with selected Screws and Washers. Make sure that each Washer (TVY11 or TVY12) is placed between the Screw and the Monitor Arm. If a Spacer (TVY9, TVY10) is required, place the Spacer between the television and the Monitor Arm. **DO NOT PLACE THE WASHERS BETWEEN THE ARMS AND THE TELEVISION.**

Fig. 2-6

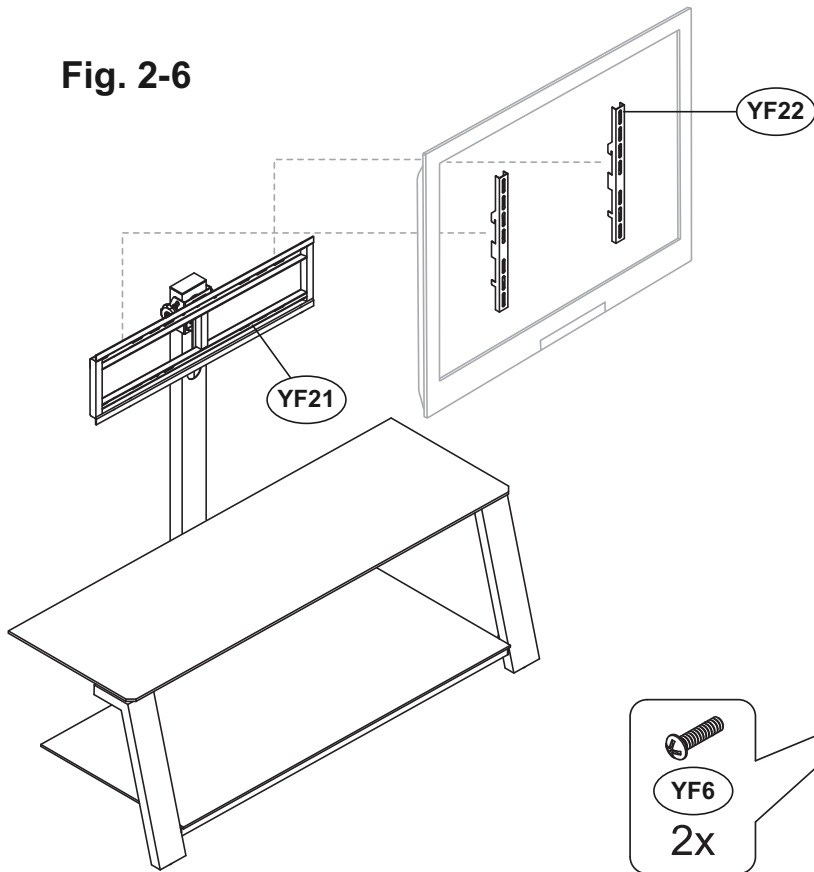
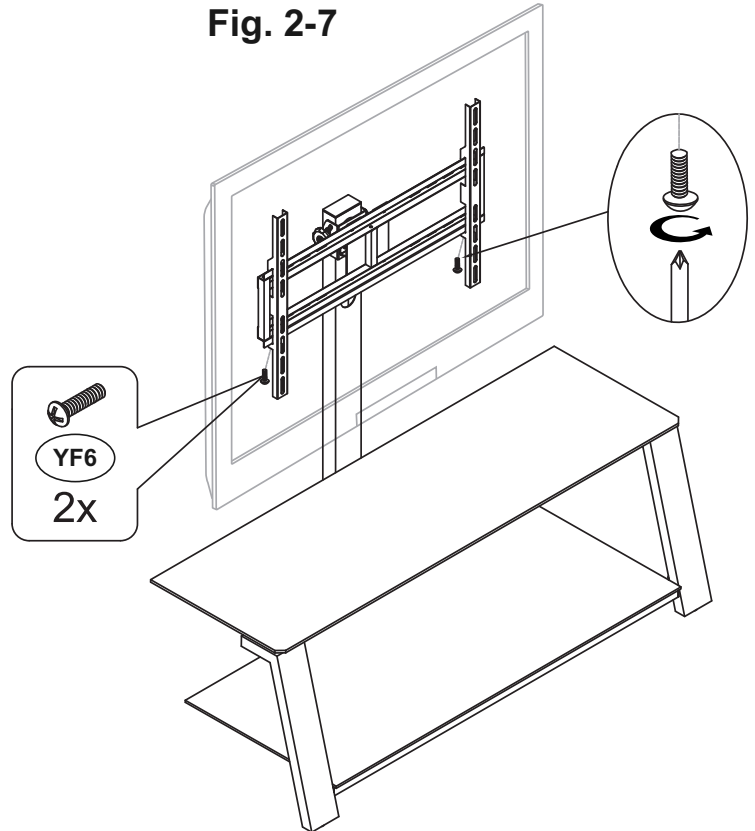

Fig. 2-7



2-9. **With the help of an assistant**, carefully **ATTACH** the TV with Monitor Arms (YF22) to the Mounting Bracket (YF21) and **SECURE** the Monitor Arms using two 25 mm Screw (YF6) as shown in Fig. 2-7. **Tighten Screws fully.**

OPTION 3: STAND WITH WALL MOUNT

CAUTION: NEVER EXCEED THE MAXIMUM LOAD CAPACITY OF 125 LBS (56.7 KG)

Fig. 3-1

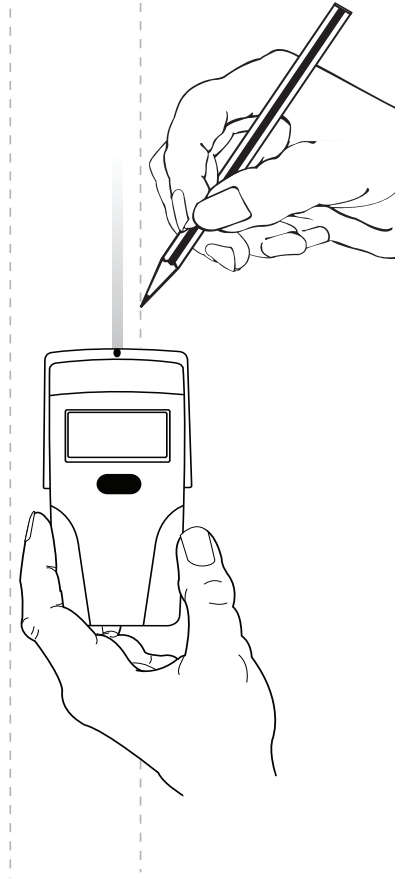

3-1 Using a stud finder, **FIND** the exact location of the studs to which you want to attach the Wall Mount (YF21). **MARK** the right and left side to determine the center of each stud. [FIGURE 3-1]

Fig. 3-2

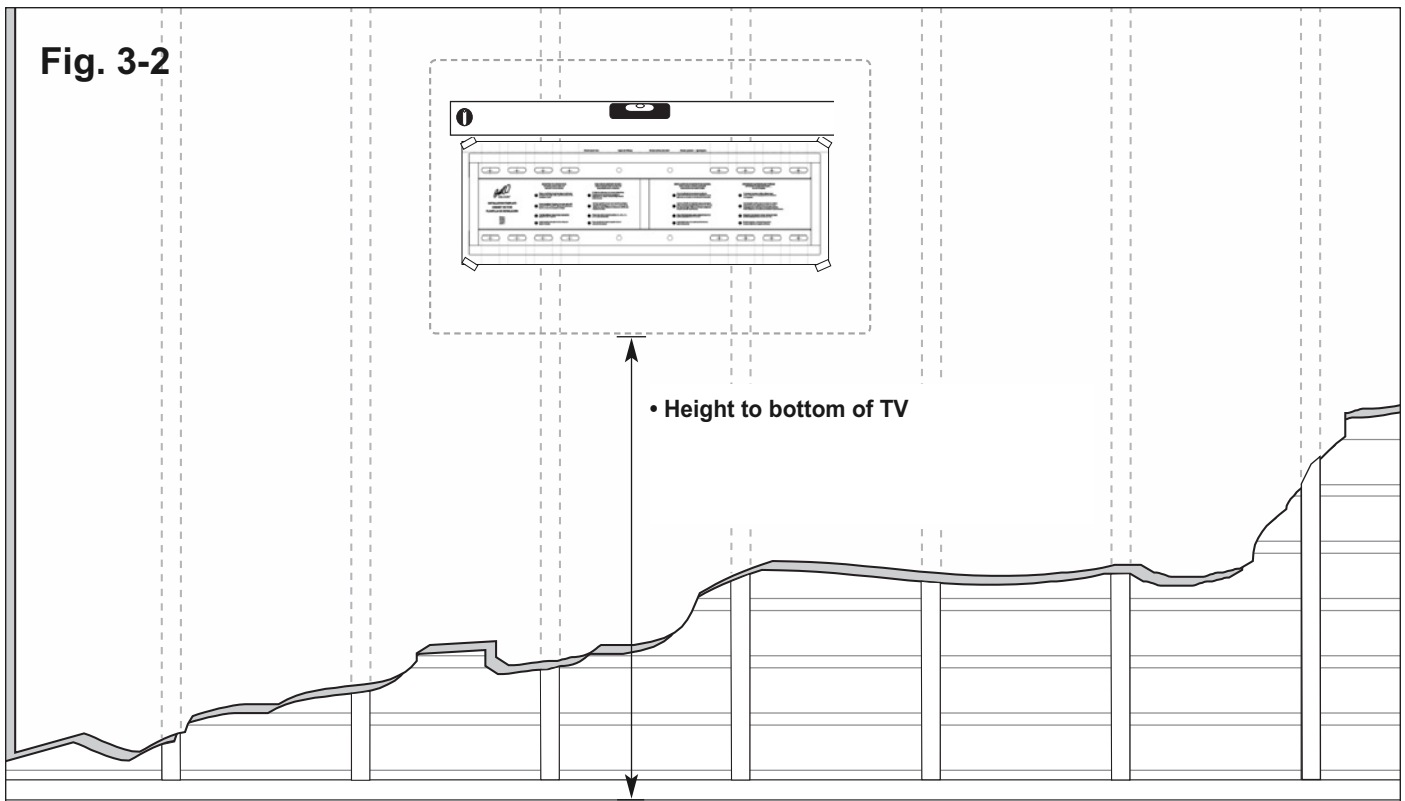

- 3-2. **MEASURE** the distance from the mounting holes on the back of your television to the top and bottom edges of the television to determine the true center of the television once it will be mounted. Many television manufacturers do not place the mounting holes exactly centered in the television.
- 3-3. **MEASURE** from the floor up, and make small marks on the wall to help you determine the desired TV height. Using a level, **LINE UP** the Installation Template with your pencil markings and **TAPE** it into place. [FIGURE 3-2]

Fig. 3-3

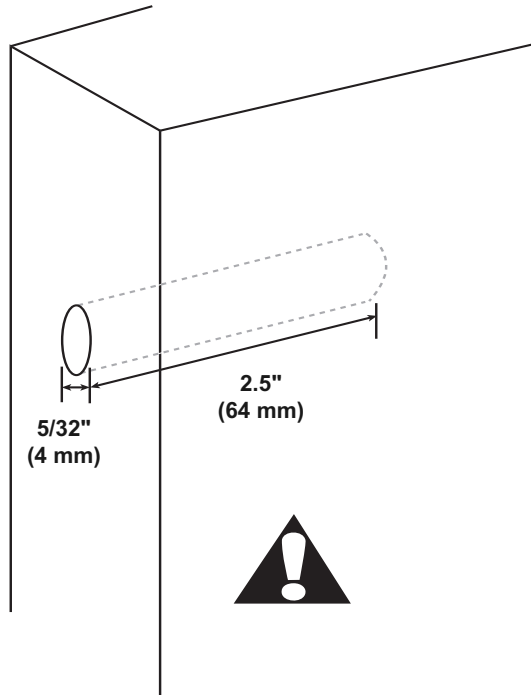

INSTALLING THE WALL MOUNT IN WOOD:

3-4. **DRILL** four holes 2.5" (64 mm) deep using a 5/32" (or 4 mm) size drill bit in the "A", "B", "C", and "D" locations noted on the Installation Template.

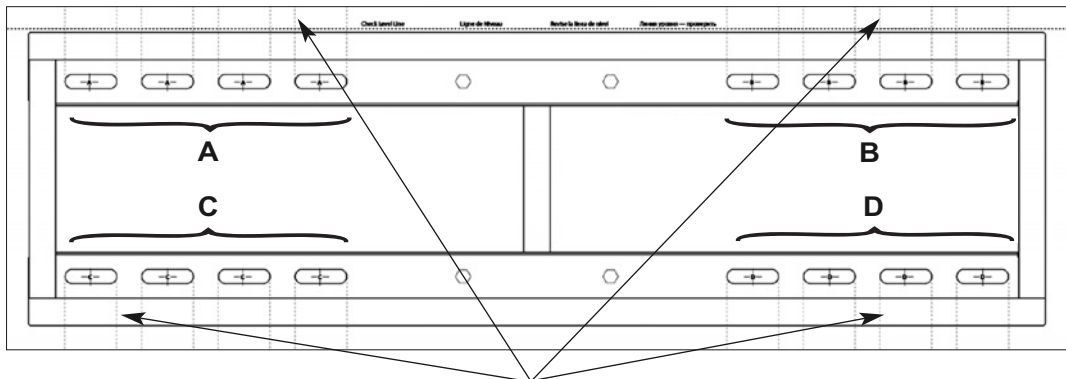
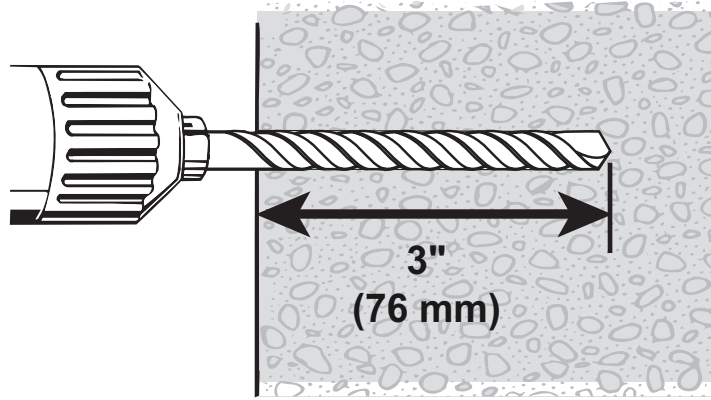

Fig. 3-4

USE LINES ON INSTALLATION TEMPLATE TO ALIGN TEMPLATE WITH STUD PENCIL MARKINGS.

Fig. 3-5



MOUNTING TO SOLID CONCRETE OR CINDER BLOCK:

3-4. Carefully **DRILL** four holes using a 5/16" (or 8mm) masonry drill bit in the "A", "B", "C", and "D" locations noted on the Installation Template. **NOTE: EACH HOLE SHOULD BE AT LEAST 3" (76 MM) DEEP.** [FIGURE 3-5]

IMPORTANT: DO NOT DRILL INTO MORTAR JOINTS! DRILL HOLES AT LEAST 1" (25.4 MM) FROM THE JOINTS.

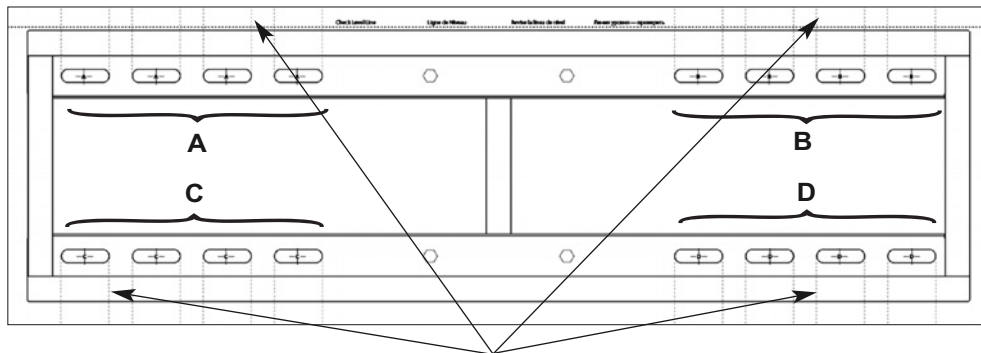

Fig. 3-6

USE LINES ON INSTALLATION TEMPLATE TO ALIGN TEMPLATE WITH STUD PENCIL MARKINGS.

3-5. **REMOVE** the Installation Template.

3-6. If mounting into concrete, **INSERT** four TOGGLER® brand Wall Anchors (YF25) into the drilled holes. [FIGURE 3-9]

3-7. **PLACE** the Wall Plate (YF21) over the holes and **SCREW** in the Lag Bolts (YF26) about half way. Use a **LEVEL** to make sure the Wall Plate is level and make any necessary adjustments. Once straight, **TIGHTEN** all of the Lag Bolts completely (**DO NOT OVER TIGHTEN!**)

Fig. 3-7

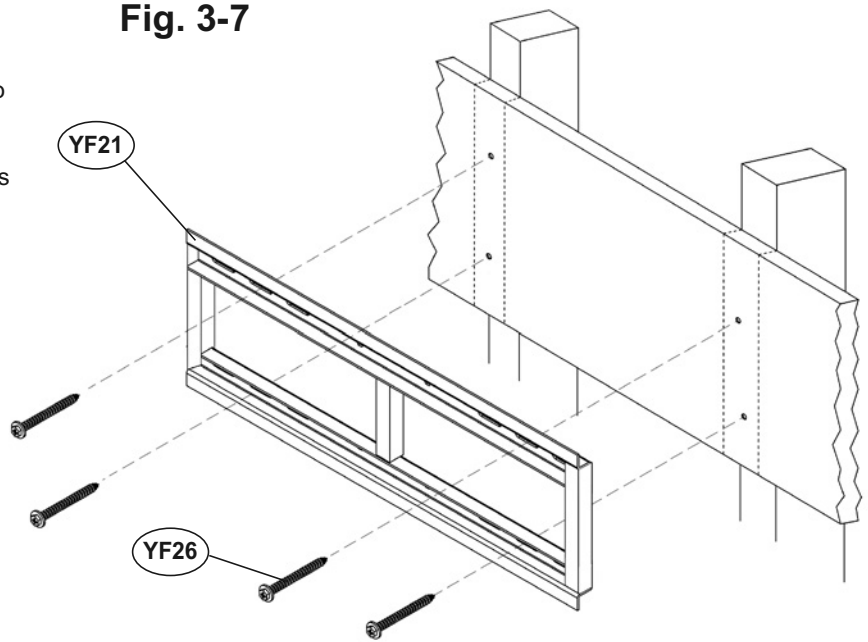

Fig. 3-8

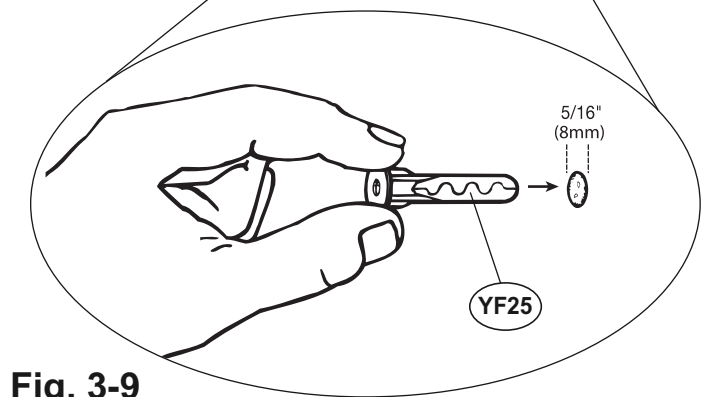
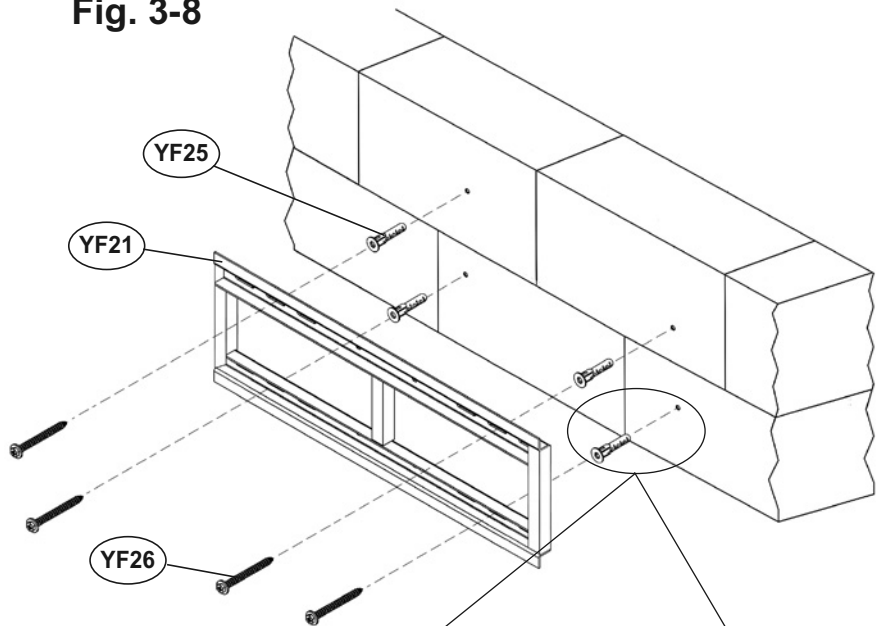
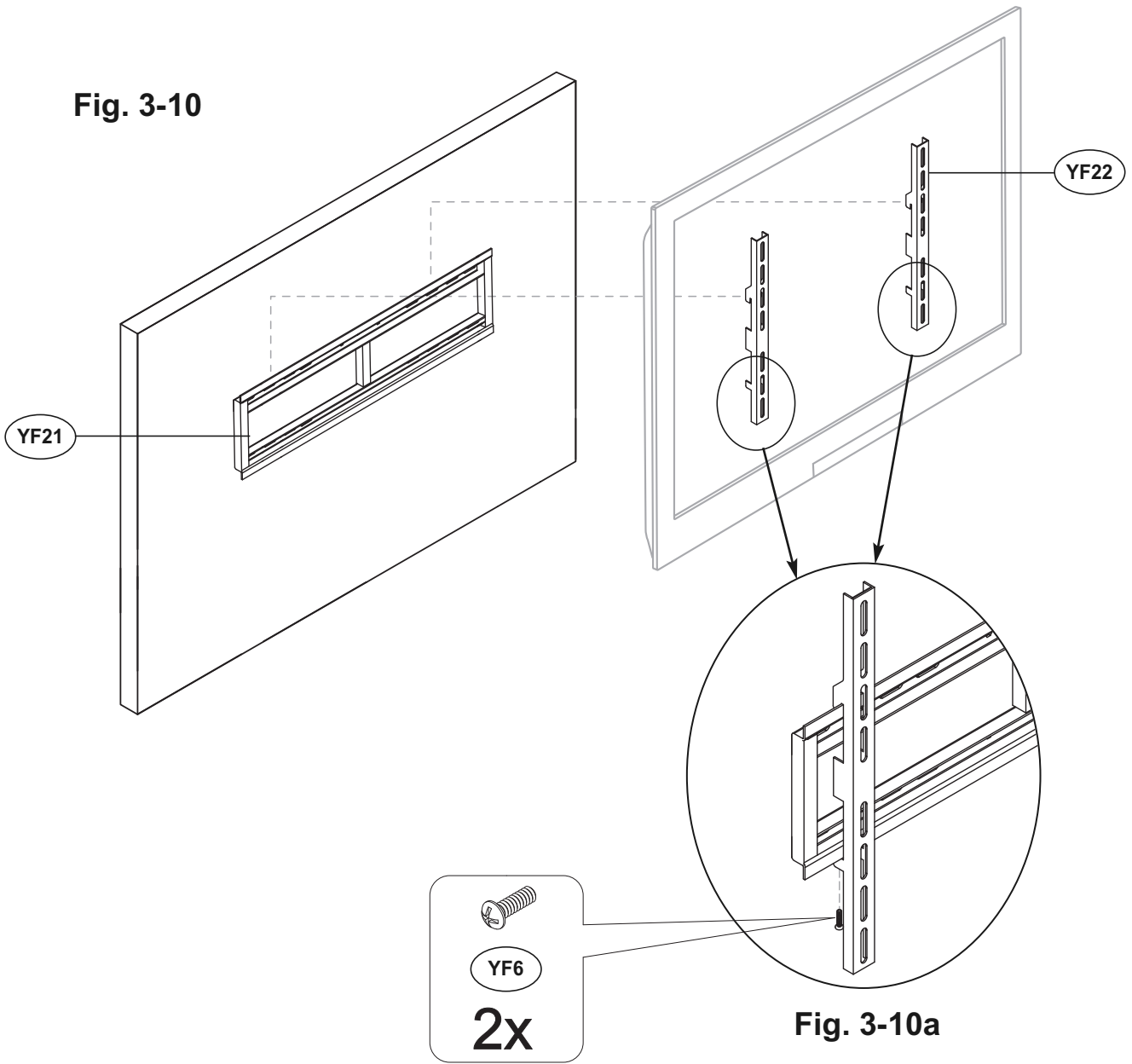

Fig. 3-9

Fig. 3-10



3-8. **With the help of an assistant**, carefully **LIFT** and **ATTACH** the TV with the Monitor Arms (YF22) to the Wall Plate (YF21). **MAKE SURE** both Monitor Arms are correctly attached, then **SECURE** the Monitor Arms using two 25 mm Screws (YF6) as shown in Fig. 3-10a. **Tighten fully.**