

AT306

Bell'O
simply...beautiful®

A/V Tower



27"W X 20"D X 36"H



VIBRANT
ESPRESSO
FINISH

AT306

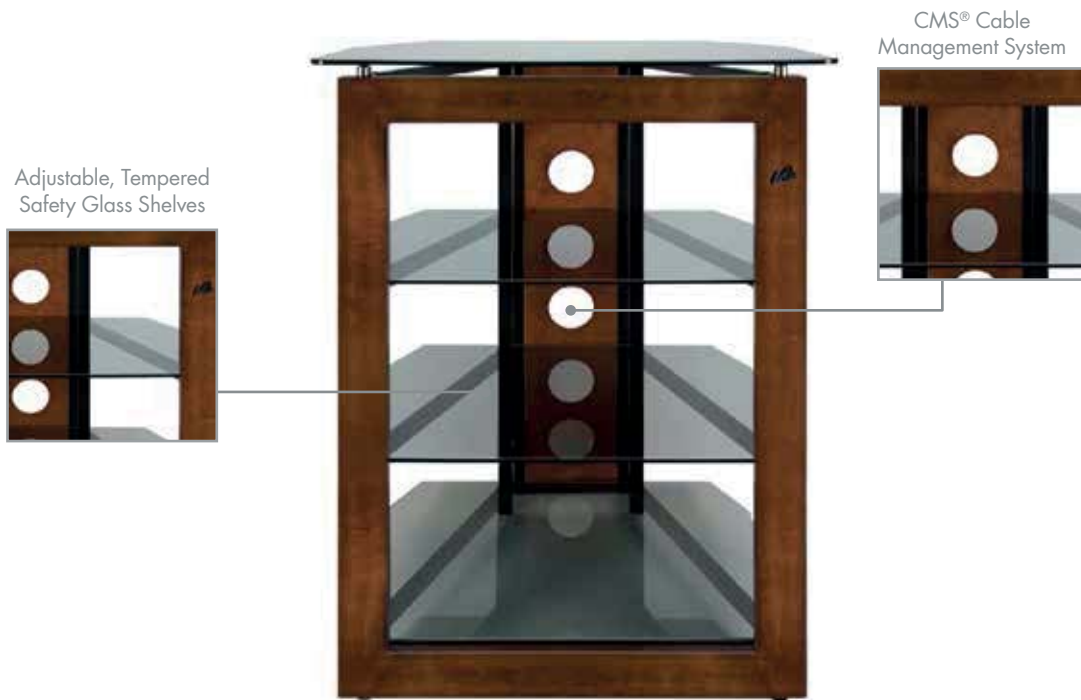

FEATURES

A/V Capacity

Accommodates at least 3 audio/video components

Adjustable Shelves

Shelves can be readjusted or removed completely

CMS® Cable Management System

An integrated CMS® Cable Management system to hide and route unsightly wire and cables

Assembles in Minutes

Assembles in minutes with no tools required.

Real Wood

Real wood frame in a Vibrant Espresso finish provides a polished sheen and brings out the character of the furniture

Contemporary Design

Simple design blends into any setting

Exceptional Quality

Fine furniture quality construction and finish

Warranty

1 year limited warranty

AVAILABLE FINISHES



Vibrant Espresso Finish

ATC402

Bell'O
simply...beautiful®

A/V Cabinet



24"W X 22"D X 42"H



DARK
ESPRESSO
FINISH

ATC402

Tempered Glass-Framed
Door Panels



Adjustable Shelves



Adjustable, Soft Close
European Hinges



CMS® Cable
Management System

FEATURES

A/V Capacity

Accommodates at least 4 audio/video components

Adjustable Shelves

Shelves can be readjusted or removed completely

CMS® Cable Management System

An integrated CMS® Cable Management system to hide and route unsightly wire and cables

Assembles in Minutes

Assembles in minutes with no tools required.

Tinted, Tempered, Safety Glass Door Panels

Display storage with tempered, tinted glass pane doors

Contemporary Design

Simple design blends into any setting

Exceptional Quality

Fine furniture quality construction and finish

Warranty

1 year limited warranty

AVAILABLE FINISHES



Dark Espresso Finish

ATCA90111-M342

Bell'O
simply...beautiful®

Audio Cabinet with Lift Top for Turntable



23.5"W X 22"D X 42"H



ESPRESSO
PINE FINISH

ATCA90111-M342

Flip-Top Storage Ideal for
Record Player Access



Adjustable Shelves

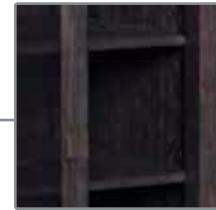

FEATURES

A/V Capacity

Accommodates at least 4 audio/video components

Adjustable Shelves

Shelves can be readjusted or removed completely

CMS® Cable Management System

An integrated CMS® Cable Management system to hide and route unsightly wire and cables

Assembles in Minutes

Assembles in minutes with no tools required.

Tinted Tempered Safety Glass Door Panels

Display storage with tinted, tempered glass pane doors

Contemporary Design

Simple design blends into any setting

Exceptional Quality

Fine furniture quality construction and finish

Warranty

1 year limited warranty

AVAILABLE FINISHES



Espresso Finish

AVSC2155

Bell'O
simply...beautiful®

TV Stand for TVs up to 65"



60"W X 18"D X 22"H



ESPRESSO
FINISH

AVSC2155



Tempered Safety
Glass Shelves



CMS® Cable
Management System

FEATURES

TV Capacity

Accommodates most flat screen TVs up to 65" or up to 90 lbs.

A/V Capacity

Accommodates at least 4 audio/video components

CMS® Cable Management System

An integrated CMS® Cable Management system to hide and route unsightly wire and cables

Assembles in Minutes

Assembles in minutes with no tools required.

Open Storage Shelves

Open display storage with unique hanging component shelf design

Real Wood

Real wood front and sides in an Espresso finish provides a polished sheen and brings out the character of the furniture

Tempered Safety Glass

Elegant, black, tempered safety glass top and shelves

Contemporary Design

Simple design blends into any setting

Exceptional Quality

Fine furniture quality construction and finish

Warranty

1 year limited warranty

AVAILABLE FINISHES



Espresso Finish



AVSC4260

Bell'O
simply...beautiful®

TV Stand for TVs up to 65"



60"W X 20"D X 22"H



MEDIUM
ESPRESSO
FINISH

AVSC4260



Tempered Safety
Glass Shelves

CMS® Cable
Management System

FEATURES

TV Capacity

Accommodates most flat screen TVs up to 65" or up to 90 lbs.

A/V Capacity

Accommodates at least 4 audio/video components

CMS® Cable Management System

An integrated CMS® Cable Management system to hide and route unsightly wire and cables

Assembles in Minutes

Assembles in minutes with no tools required.

Open Architecture Design

Open display storage provides ventilation for components

Real Wood

Real wood frame in a Medium Espresso finish provides a polished sheen and brings out the character of the furniture

Tempered Safety Glass

Elegant black tempered safety glass top and shelves

Contemporary Design

Simple design blends into any setting

Exceptional Quality

Fine furniture quality construction and finish

Warranty

1 year limited warranty

AVAILABLE FINISHES



Medium Espresso Finish



COOPER

BFA50-94892-MDC

Bell'O
simply...beautiful®

TV Stand for TVs up to 55"



50"W X 19"D X 24"H



DARK
CHERRY
FINISH

COOPER

BFA50-94892-MDC



Black Tempered Safety Glass Shelves



Real, Curved Wood with Black Chrome Posts



CMS® Cable Management System

FEATURES

TV Capacity

Accommodates most flat screen TVs up to 55" or up to 55 lbs.

A/V Capacity

Accommodates at least 4 audio/video components

CMS® Cable Management System

An integrated CMS® Cable Management system to hide and route unsightly wire and cables

Easy Assembly

Easy-to-assemble, includes an owner's manual and easy-to-follow instructions

Open Architecture Design

Open architecture design provides plenty of air circulation for convection cooling of components

S-shaped sides

With black chrome posts and a scratch resistant, powder-coated metal frame

Real Wood

Real curved wood in a Dark Cherry finish provides a polished sheen and brings out the character of the furniture

Tempered Safety Glass

Elegant black tempered safety glass top and shelves

Contemporary Design

Simple design blends into any setting

Warranty

1 year limited warranty

AVAILABLE FINISHES



Dark Cherry Finish (MDC)

Bell'O
simply...beautiful®

CHELSEA

BFA50-94898-DE1

Bell'O
simply...beautiful®

TV Stand for TVs up to 55"



50"W X 19"D X 23"H



DARK
ESPRESSO
FINISH

CHELSEA

BFA50-94898-DE1



Tinted Tempered Safety Glass Shelves



Real Curved Wood



Chrome Details



CMS® Cable Management System

FEATURES

TV Capacity

Accommodates most flat screen TVs up to 55" or up to 55 lbs.

A/V Capacity

Accommodates at least 4 audio/video components

CMS® Cable Management System

An integrated CMS® Cable Management system to hide and route unsightly wire and cables

Easy Assembly

Easy-to-assemble, includes an owner's manual and easy-to-follow instructions

Open Architecture Design

Open architecture design provides plenty of air circulation for convection cooling of components

Real Wood

Real curved wood in a Dark Espresso finish provides a polished sheen and brings out the character of the furniture

Tempered Safety Glass

Elegant, tinted, tempered safety glass top and shelves

Contemporary Design

Simple design blends into any setting

Exceptional Quality

Fine furniture quality construction and finish

Warranty

1 year limited warranty

AVAILABLE FINISHES



Dark Espresso Finish (DE1)

Bell'O
simply...beautiful®

CHELSEA

BFA60-94898-DE1

Bell'O
simply...beautiful®

TV Stand for TVs up to 65"



60"W X 18.5"D X 23"H

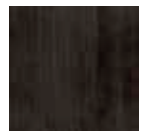

DARK
ESPRESSO
FINISH

CHELSEA

BFA60-94898-DE1



Tinted Tempered Safety Glass Shelves



Chrome Details



CMS® Cable Management System



Real Curved Wood



FEATURES

TV Capacity

Accommodates most flat screen TVs up to 65" or up to 90 lbs.

A/V Capacity

Accommodates at least 4 audio/video components

CMS® Cable Management System

An integrated CMS® Cable Management system to hide and route unsightly wire and cables

Easy Assembly

Easy-to-assemble, includes an owner's manual and easy-to-follow instructions

Open Architecture Design

Open architecture design provides plenty of air circulation for convection cooling of components

Real Wood

Real, curved wood in a Dark Espresso finish provides a polished sheen and brings out the character of the furniture

Tempered Safety Glass

Elegant, tinted, tempered safety glass top and shelves

Contemporary Design

Simple design blends into any setting

Exceptional Quality

Fine furniture quality construction and finish

Warranty

1 year limited warranty

AVAILABLE FINISHES



Dark Espresso Finish (DE1)

Bell'O
simply...beautiful®

LEHIGH

BF58-52900-H371

Bell'O
simply...beautiful®

Triple Play™ Universal Flat Panel A/V System for TVs up to 65"



58"W X 21"D X 55"H



BUXTON BROWN
ON WIRE BRUSHED BIRCH

LEHIGH

BF58-52900-H37



FEATURES

TV Capacity

Accommodates most flat screen TVs up to 65" or up to 90 lbs.

A/V Capacity

Accommodates at least 4 audio/video components

Versatile Design

Versatile design allows user to display a TV in three different ways:

1. On the included wall mount
2. On the included swivel mounting pole
3. Simply placed on the stand

CMS® Cable Management System

An integrated CMS® Cable Management system to hide and route unsightly wire and cables

Easy Assembly

Easy-to-assemble, includes an owner's manual and easy-to-follow instructions

Open Architecture Design

Open architecture design provides plenty of air circulation for convection cooling of components

Tempered Safety Glass Shelf

Buxton brown and safety glass shelves

Warranty

1 year limited warranty

AVAILABLE FINISHES



Buxton Brown on Wire Brushed Birch (H371)

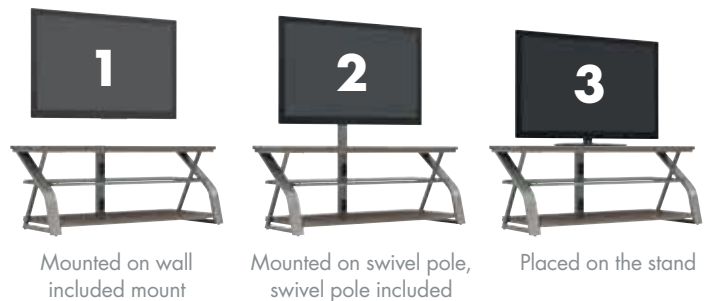

SUTTON

BFA63-94815-UCO

Bell'O
simply...beautiful®

TV Stand for TVs up to 70"



63"W X 20"D X 28"H

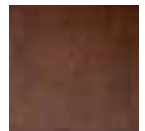

COCOA
FINISH ON
ASH WOOD

SUTTON

BFA63-94815-UCO



Adjustable Shelves



Three Center Storage Drawers



Black Metal Frame and Legs



Wood Frame Doors with Tinted Glass

FEATURES

TV Capacity

Accommodates most flat screen TVs up to 70" or up to 105 lbs.

A/V Capacity

Accommodates at least 4 audio/video components

CMS® Cable Management System

An integrated CMS® Cable Management system to hide and route unsightly wire and cables

Storage Drawers

Three center drawers provide extra storage space

2 Display Cabinets

Display storage with tinted glass doors
Measures: 18.5"W X 17"D

Tinted, Tempered, Safety Glass Doors

Help hide clutter while allowing for operation of remote controls

Adjustable Shelves

Shelves can be readjusted or removed completely for added space

Exceptional Quality

Fine furniture quality construction and finish

Warranty

1 year limited warranty

AVAILABLE FINISHES

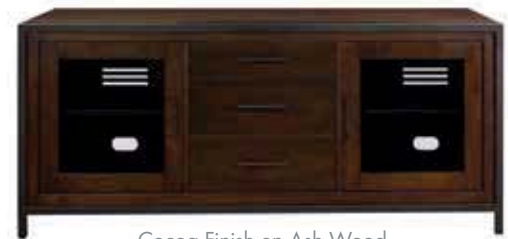

Cocoa Finish on Ash Wood

CW340

Bell'O
simply...beautiful®

TV Stand for TVs up to 47"



40"W X 18"D X 36"H



VIBRANT
ESPRESSO
FINISH

CW340



Tempered Safety Glass Shelves



Real Curved Wood with Black Chrome Posts

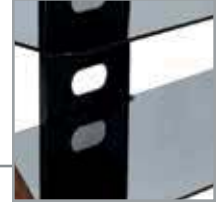

CMS® Cable Management System

FEATURES

TV Capacity

Accommodates most flat screen TVs up to 47" or up to 45 lbs.

A/V Capacity

Accommodates at least 4 audio/video components

CMS® Cable Management System

An integrated CMS® Cable Management system to hide and route unsightly wire and cables

Easy Assembly

Easy-to-assemble, includes an owner's manual and easy-to-follow instructions

Open Architecture Design

Open display storage provides ventilation for components

Real Wood

Real curved wood in a Vibrant Espresso finish provides a polished sheen and brings out the character of the furniture

Tempered Safety Glass

Elegant black tempered safety glass top and shelves

Contemporary Design

Simple design blends into any setting

Exceptional Quality

Fine furniture quality construction and finish

Warranty

1 year limited warranty

AVAILABLE FINISHES



Vibrant Espresso Finish



CW342

Bell'O
simply...beautiful®

TV Stand for TVs up to 70"



65"W X 23"D X 24"H



VIBRANT
ESPRESSO
FINISH

CW342



Tempered Safety
Glass Shelves

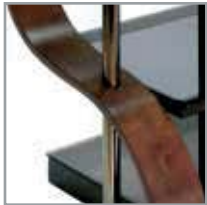

Real, Curved Wood with
Black Chrome Posts



CMS® Cable
Management System

FEATURES

TV Capacity

Accommodates most flat screen TVs up to 70" or up to 105 lbs.

A/V Capacity

Accommodates at least 4 audio/video components

CMS® Cable Management System

An integrated CMS® Cable Management system to hide and route unsightly wire and cables

Easy Assembly

Easy-to-assemble, includes an owner's manual and easy-to-follow instructions

Open Architecture Design

Open display storage provides ventilation for components

Real Wood

Real curved wood in a Vibrant Espresso finish provides a polished sheen and brings out the character of the furniture

Tempered Safety Glass

Elegant black tempered safety glass top and shelves

Contemporary Design

Simple design blends into any setting

Exceptional Quality

Fine furniture quality construction and finish

Warranty

1 year limited warranty

AVAILABLE FINISHES



Vibrant Espresso Finish

CW343

Bell'O
simply...beautiful®

TV Stand for TVs up to 55"



52"W X 18.75"D X 24"H



VIBRANT
ESPRESSO
FINISH

CW343



FEATURES

TV Capacity

Accommodates most flat screen TVs up to 55" or up to 55 lbs.

A/V Capacity

Accommodates at least 4 audio/video components

CMS® Cable Management System

An integrated CMS® Cable Management system to hide and route unsightly wire and cables

Easy Assembly

Easy-to-assemble, includes an owner's manual and easy-to-follow instructions

Open Architecture Design

Open display storage provides ventilation for components

Real Wood

Real curved wood in a Vibrant Espresso finish provides a polished sheen and brings out the character of the furniture

Tempered Safety Glass

Elegant black tempered safety glass top and shelves

Contemporary Design

Simple design blends into any setting

Exceptional Quality

Fine furniture quality construction and finish

Warranty

1 year limited warranty

AVAILABLE FINISHES

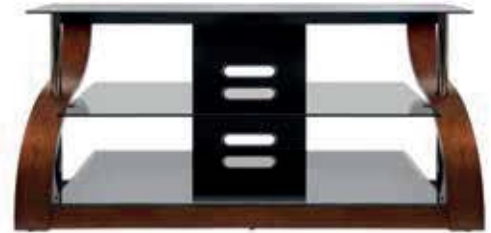

Vibrant Espresso Finish

CW349

Bell'O
simply...beautiful®

TV Stand for TVs up to 55"



52"W X 19"D X 24"H



DEEP
ESPRESSO
FINISH

CW349



FEATURES

TV Capacity

Accommodates most flat screen TVs up to 55" or up to 55 lbs.

A/V Capacity

Accommodates at least 4 audio/video components

CMS® Cable Management System

An integrated CMS® Cable Management system to hide and route unsightly wire and cables

Easy Assembly

Easy-to-assemble, includes an owner's manual and easy-to-follow instructions

Open Architecture Design

Open display storage provides ventilation for components

Real Wood

Real curved wood in a Deep Espresso finish provides a polished sheen and brings out the character of the furniture

Tempered Safety Glass

Elegant black tempered safety glass top and shelves

Contemporary Design

Simple design blends into any setting

Exceptional Quality

Fine furniture quality construction and finish

Warranty

1 year limited warranty

AVAILABLE FINISHES



Deep Espresso Finish

CW356

Bell'O
simply...beautiful®

TV Stand for TVs up to 60"



56"W X 19"D X 24"H



RICH CARAMEL
BROWN FINISH

CW356



FEATURES

TV Capacity

Accommodates most flat screen TVs up to 60" or up to 75 lbs.

A/V Capacity

Accommodates at least 4 audio/video components

CMS® Cable Management System

An integrated CMS® Cable Management system to hide and route unsightly wire and cables

Easy Assembly

Easy-to-assemble, includes an owner's manual and easy-to-follow instructions

Open Architecture Design

Open display storage provides ventilation for components

Real Wood

Real curved wood in a Rich Caramel Brown finish provides a polished sheen and brings out the character of the furniture

Tempered Safety Glass

Elegant black tempered safety glass top and shelves

Contemporary Design

Simple design blends into any setting

Exceptional Quality

Fine furniture quality construction and finish

Warranty

1 year limited warranty

AVAILABLE FINISHES



Rich Caramel Brown Finish

PR45

Bell'O
simply...beautiful®

TV Stand for TVs up to 70"



65"W X 22"D X 28"H



COCOA
FINISH

PR45



FEATURES

TV Capacity

Accommodates most flat screen TVs up to 70" or up to 105 lbs.

A/V Capacity

Accommodates at least 9 audio/video components

CMS® Cable Management System

An integrated CMS® Cable Management system to hide and route unsightly wire and cables

Open Media Shelf

Ideal for large soundbars or for storing electronic media components

Tinted Tempered Safety Glass Doors

Help hide clutter while allowing for operation of remote controls

Adjustable Shelves

Shelves can be readjusted or removed completely for added space

Removable Back Panels

Removable back panels for easy component access

Exceptional Quality

Fine furniture quality construction and finish

Warranty

1 year limited warranty

AVAILABLE FINISHES



Cocoa Finish

PVS3103

Bell'O
simply...beautiful®

TV Stand for TVs up to 55"



47.25"W X 20"D X 22.25"H



DARK
CHERRY
FINISH

PVS3103



Scallop-edged Front



Tempered Safety Glass Shelves



Unique, Wood-Inspired Hand Painted Metal Front

FEATURES

TV Capacity

Accommodates most flat screen TVs up to 55" or up to 55 lbs.

A/V Capacity

Accommodates at least 4 audio/video components

CMS® Cable Management System

Interior slots hide and route unsightly wires and provide proper air circulation for your components

Easy Assembly

Easy-to-assemble, includes an owner's manual and easy-to-follow instructions

Open Architecture Design

Provides ventilation for components and features a unique beautiful, scallop-edged front

Wood-Inspired Metal Front

Unique, wood metal, hand painted in a Dark Cherry finish provides a polished sheen and brings out the character of the furniture

Tempered Safety Glass

Elegant, tinted, tempered safety glass top and shelves

Contemporary Design

Simple design blends into any setting

Exceptional Quality

Fine furniture quality construction and finish

Warranty

1 year limited warranty

AVAILABLE FINISHES



Dark Cherry Finish

PVS4204HG

Bell'O
simply...beautiful®

TV Stand for TVs up to 47"



42"W X 18"D X 22"H



HIGH GLOSS
BLACK FINISH

PVS4204HG



Black Safety Glass Shelves



CMS® Cable Management System



Curved Metal Frame

FEATURES

TV Capacity

Accommodates most flat screen TVs up to 47" or up to 45 lbs.

A/V Capacity

Accommodates at least 4 audio/video components

CMS® Cable Management System

An integrated CMS® Cable Management system to hide and route unsightly wire and cables

Easy Assembly

Easy-to-assemble, includes an owner's manual and easy-to-follow instructions

Open Architecture Design

Provides ventilation for components and features a unique beautiful, scallop-edged front

Sleek and Modern

Curved front legs and a High Gloss Black scratch resistant, powder-coated metal frame

Real Wood

Real curved wood in a High Gloss Black finish provides a polished sheen and brings out the character of the furniture

Tempered Safety Glass

Elegant black tempered safety glass top and shelves

Contemporary Design

Simple design blends into any setting

Warranty

1 year limited warranty

AVAILABLE FINISHES



High Gloss Black Finish



PVS4206HG

Bell'O
simply...beautiful®

TV Stand for TVs up to 55"



52"W X 18"D X 22"H

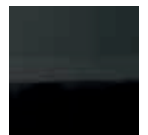

HIGH GLOSS
BLACK FINISH

PVS4206HG



FEATURES

TV Capacity

Accommodates most flat screen TVs up to 55" or up to 55 lbs.

A/V Capacity

Accommodates at least 4 audio/video components

CMS® Cable Management System

An integrated CMS® Cable Management system to hide and route unsightly wire and cables

Easy Assembly

Easy-to-assemble, includes an owner's manual and easy-to-follow instructions

Open Architecture Design

Provides ventilation for components and features a unique beautiful, scallop-edged front

Sleek and Modern

Curved front legs and a High Gloss Black scratch resistant, powder-coated metal frame

Real Wood

Real, curved wood in a High Gloss Black finish provides a polished sheen and brings out the character of the furniture

Tempered Safety Glass

Elegant, tint, tempered safety glass shelves

Contemporary Design

Simple design blends into any setting

Warranty

1 year limited warranty

AVAILABLE FINISHES



High Gloss Black Finish

Bell'O
simply...beautiful®

PVS4208HG

Bell'O
simply...beautiful®

TV Stand for TVs up to 47"



44"W X 18"D X 22"H

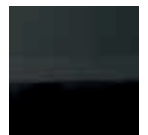

HIGH GLOSS
BLACK FINISH

PVS4208HG



FEATURES

TV Capacity

Accommodates most flat screen TVs up to 47" or up to 45 lbs.

A/V Capacity

Accommodates at least 4 audio/video components

CMS® Cable Management System

An integrated CMS® Cable Management system to hide and route unsightly wire and cables

Easy Assembly

Easy-to-assemble, includes an owner's manual and easy-to-follow instructions

Open Architecture Design

Provides ventilation for components and features a unique beautiful, scallop-edged front

Sleek and Modern

Curved front legs and a High Gloss Black scratch resistant, powder-coated metal frame

Tempered Safety Glass

Elegant, black, tempered safety glass top and shelves

Contemporary Design

Simple design blends into any setting

Warranty

1 year limited warranty

AVAILABLE FINISHES

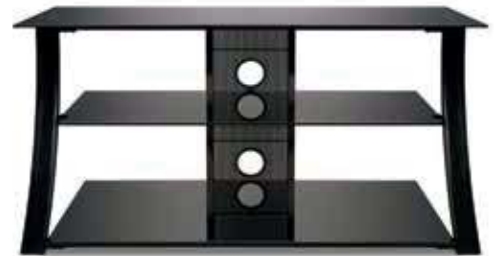

High Gloss Black Finish

PVS4252

Bell'O
simply...beautiful®

TV Stand for TVs up to 55"



52"W X 21"D X 22.5"H



HIGH GLOSS
BLACK FINISH

PVS4252



Black Safety Glass Shelves



Brushed Nickel Base



CMS® Cable Management System

FEATURES

TV Capacity

Accommodates most flat screen TVs up to 55" or up to 55 lbs.

A/V Capacity

Accommodates at least 4 audio/video components

CMS® Cable Management System

An integrated CMS® Cable Management system to hide and route unsightly wire and cables

Easy Assembly

Easy-to-assemble, includes an owner's manual and easy-to-follow instructions

Open Architecture Design

Provides ventilation for components and features a unique beautiful, scallop-edged front

Sleek and Modern

Curved front legs and a High Gloss Black scratch resistant, powder-coated metal frame

Tempered Safety Glass

Elegant, black, tempered safety glass top and shelves

Contemporary Design

Simple design blends into any setting

Warranty

1 year limited warranty

AVAILABLE FINISHES



High Gloss Black Finish

PVS4257

Bell'O
simply...beautiful®

TV Stand for TVs up to 55"



52"W X 17.75"D X 23.5"H



DARK
PEWTER
FINISH

PVS4257



Black Safety Glass Shelves



Picture Frame Front



CMS® Cable Management System

FEATURES

TV Capacity

Accommodates most flat screen TVs up to 55" or up to 55 lbs.

A/V Capacity

Accommodates at least 4 audio/video components

CMS® Cable Management System

An integrated CMS® Cable Management system to hide and route unsightly wire and cables

Easy Assembly

Easy-to-assemble, includes an owner's manual and easy-to-follow instructions

Open Architecture Design

Provides ventilation for components and features a unique beautiful, scallop-edged front

Sleek and Modern

Curved front legs and a High Gloss Black scratch resistant, powder-coated metal frame

Tempered Safety Glass

Elegant, black, Tempered safety glass top and shelves

Contemporary Design

Simple design blends into any setting

Warranty

1 year limited warranty

AVAILABLE FINISHES



Dark Pewter Finish

ENTERPRISE

TC60-9616-NB03

Bell'O
simply...beautiful®

TV Stand for TVs up to 65"



59.5"W X 19.5"D X 21"H



HIGH GLOSS
BLACK FINISH

ENTERPRISE

TC60-9616-NB03

Open Center Media shelf
with CMS® Cable Management System



Adjustable Shelves



Smoked Glass,
Tempered Doors



FEATURES

TV Capacity

Accommodates most flat screen TVs up to 65" or up to 90 lbs.

A/V Capacity

Accommodates at least 4 audio/video components

CMS® Cable Management System

An integrated CMS® Cable Management system to hide and route unsightly wire and cables

Easy Assembly

Easy-to-assemble, includes an owner's manual and easy-to-follow instructions

Two Side Storage Cabinets

Shelves can be readjusted or removed completely for added space

Modern Design

Features smoked glass and graphite metal legs

Exceptional Quality

Fine furniture quality construction and finish

Warranty

3 year limited warranty

AVAILABLE FINISHES



High Gloss Black Finish (NB03)

TC63-50005-Z380

Bell'O
simply...beautiful®

TV Stand for TVs up to 70"



63"W X 19.5"D X 28"H



OLD WORLD
PECAN FINISH

TC63-50005-Z380

Partitioned Media Shelf w/ Wire Management Channels



Plank Top



Black Frame Legs



Side Storage Cabinets

FEATURES

TV Capacity

Accommodates most flat screen TVs up to 70" or up to 105 lbs.

A/V Capacity

Accommodates at least 5 audio/video components

CMS® Cable Management System

An integrated CMS® Cable Management system to hide and route unsightly wire and cables

Easy Assembly

Easy-to-assemble, includes an owner's manual and easy-to-follow instructions

Full Length Media Shelf w/ Recessed Partitions

Ideal for sound bars and media components

Architectural Detailing

Plank top with black frame legs and faux drawer door fronts

Exceptional Quality

Fine furniture quality construction and finish

Warranty

1 year limited warranty

AVAILABLE FINISHES



Old World Pecan Finish (Z380)

FULTON

TC63-9943-O149

Bell'O
simply...beautiful®

TV Stand for TVs up to 70"



63"W X 20"D X 28"H

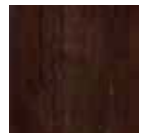

COCOA
FINISH

FULTON

TC63-9943-O149

Black Metal Frame



Wood Frame Doors
with Tinted Glass



CMS® Cable
Management System

FEATURES

TV Capacity

Accommodates most flat screen TVs up to 70" or up to 105 lbs.

A/V Capacity

Accommodates at least 4 audio/video components

CMS® Cable Management System

An integrated CMS® Cable Management system to hide and route unsightly wire and cables

Assembles in Minutes

Quick and easy-to-assemble, includes an owner's manual and easy to follow instructions

Storage Drawers

Three center pull-out drawers provide extra storage space

2 Display Cabinets

Display Storage with tinted glass doors
Measures: 18.5"W X 17"D

Tinted Tempered Safety Glass Door Panels

Help hide clutter while allowing for operation of remote controls

Adjustable Shelving

Shelves can be readjusted or removed completely for added space

Exceptional Quality

Fine furniture quality construction and finish

Warranty

1 year limited warranty

AVAILABLE FINISHES



Cocoa Finish (0149)

PHONIC

TCS55-1372HG

Bell'O
simply...beautiful®

TV Stand with Two Speaker Sound Bar for TVs up to 60"



 **Bluetooth®**
sound by
bell'o digital

54"W X 20.25"D X 24"H

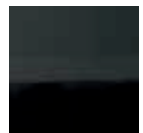

GLOSS
BLACK
FINISH

PHONIC

TCS55-1372HG



 **Bluetooth®**
sound by
bell'o digital®

Bell'O Digital Speakers w/
Bluetooth® Connectivity



Open Architecture Design
w/ CMS® Cable
Management System



Tinted Tempered
Safety Glass Shelves

FEATURES

TV Capacity

Accommodates most flat screen TVs up to 60" or up to 75 lbs.

A/V Capacity

Accommodates at least 4 audio/video components

CMS® Cable Management System

An integrated CMS® Cable Management system to hide and route unsightly wire and cables

Easy Assembly

Easy-to-assemble, includes an owner's manual and easy-to-follow instructions

Built-in-Speakers

Premium Bell'O Digital® speakers provide high quality audio

Bluetooth® Audio Streaming

Stream audio from any Bluetooth® enabled device directly to the speakers

Open Architecture Design

Provides plenty of air circulation for convection cooling of components

Exceptional Quality

Fine furniture quality construction and finish

Warranty

1 year limited warranty

AVAILABLE FINISHES



Gloss Black Finish

simply...beautiful®

The Bluetooth® word mark and logos are registered trademarks owned by Bluetooth SIG, Inc. and any use of such marks by Twin-Star, International is under license. Other trademarks and trade names are those of their respective owners.

TP4444

Bell'O
simply...beautiful®

Triple Play™ Universal Flat Panel A/V System for TVs up to 55"

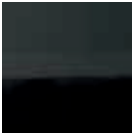

44"W X 19.5"D X 50"H

HIGH GLOSS
BLACK FINISH

TP4444



Tinted Tempered Safety Glass Shelves



CMS® Cable Management System

FEATURES

TV Capacity

Accommodates most flat screen TVs up to 55" or up to 55 lbs.

A/V Capacity

Accommodates at least 4 audio/video components

Versatile Design

Versatile design allows user to display a TV in **three different ways**:

1. On the included wall mount
2. On the included swivel mounting pole
3. Simply placed on the stand

CMS® Cable Management System

An integrated CMS® Cable Management system to hide and route unsightly wire and cables

Easy Assembly

Easy-to-assemble, includes an owner's manual and easy-to-follow instructions

Open Architecture Design

Provides plenty of air circulation for convection cooling of components

Tempered Safety Glass

Elegant, tinted, tempered safety glass top and shelves

Warranty

1 year limited warranty

AVAILABLE FINISHES



High Gloss Black Finish



1
Mounted on wall included mount



2
Mounted on swivel pole, swivel pole included



3
Placed on the stand



TP4452

Bell'O
simply...beautiful®

Triple Play™ Universal Flat Panel A/V System for TVs up to 60"



52"W X 19.5"D X 50"H



HIGH GLOSS
BLACK FINISH

TP4452



Tinted, Tempered Safety Glass Shelves

Pass Through Holes for Easy Wire Management

FEATURES

TV Capacity

Accommodates most flat screen TVs up to 60" or up to 75 lbs.

A/V Capacity

Accommodates at least 4 audio/video components

Versatile Design

Versatile design allows user to display a TV in **three different ways**:

1. On the included swivel mounting pole
2. On the included wall mount
3. Simply placed on the stand

CMS® Cable Management System

An integrated CMS® Cable Management system to hide and route unsightly wire and cables

Easy Assembly

Easy-to-assemble, includes an owner's manual and easy-to-follow instructions

Open Architecture Design

Provides plenty of air circulation for convection cooling of components

Tempered Safety Glass

Elegant, tinted, tempered safety glass top and shelves

Warranty

1 year limited warranty

AVAILABLE FINISHES



High Gloss Black Finish



Mounted on wall included mount



Mounted on swivel pole, swivel pole included



Placed on the stand

TP4463

Bell'O
simply...beautiful®

Triple Play™ Universal Flat Panel A/V System for TVs up to 70"



63"W X 19.5"D X 50"H



HIGH GLOSS
BLACK FINISH

TP4463



Tinted Tempered Safety Glass Shelves



CMS® Cable Management System

FEATURES

TV Capacity

Accommodates most flat screen TVs up to 60" or up to 75 lbs.

A/V Capacity

Accommodates at least 4 audio/video components

Versatile Design

Versatile design allows user to display a TV in **three different ways**:

1. On the included wall mount
2. On the included swivel mounting pole
3. Simply placed on the stand

CMS® Cable Management System

An integrated CMS® Cable Management system to hide and route unsightly wire and cables

Easy Assembly

Easy-to-assemble, includes an owner's manual and easy-to-follow instructions

Open Architecture Design

Provides plenty of air circulation for convection cooling of components

Tempered Safety Glass

Elegant, tinted, tempered safety glass top and shelves

Warranty

1 year limited warranty

AVAILABLE FINISHES



High Gloss Black Finish



1
Mounted on wall included mount

2
Mounted on swivel pole, swivel pole included

3
Placed on the stand

TP4501

Bell'O
simply...beautiful®

Triple Play™ Universal Flat Panel A/V System for TVs up to 55"



42"W X 20"D X 59"H



DARK
CHERRY
FINISH

TP4501



Tinted Tempered Safety Glass Shelves



CMS® Cable Management System

FEATURES

TV Capacity

Accommodates most flat screen TVs up to 55" or up to 55 lbs.

A/V Capacity

Accommodates at least 4 audio/video components

Versatile Design

Versatile design allows user to display a TV in **three different ways**:

1. On the included wall mount
2. On the included swivel mounting pole
3. Simply placed on the stand

CMS® Cable Management System

An integrated CMS® Cable Management system to hide and route unsightly wire and cables

Easy Assembly

Easy-to-assemble, includes an owner's manual and easy-to-follow instructions

Open Architecture Design

Provides plenty of air circulation for convection cooling of components

Tempered Safety Glass

Elegant, tinted, tempered safety glass top and shelves

Warranty

1 year limited warranty

AVAILABLE FINISHES



Dark Cherry Finish



1
Mounted on wall included mount

2
Mounted on swivel pole, swivel pole included

3
Placed on the stand

Bell'O
simply...beautiful®

TPC2133

Bell'O
simply...beautiful®

Triple Play™ Universal Flat Panel A/V System for TVs up to 60"



52"W X 22"D X 59"H



DARK
ESPRESSO
FINISH

TPC2133



Tinted Tempered Safety Glass Shelves



CMS® Cable Management System

FEATURES

TV Capacity

Accommodates most flat screen TVs up to 60" or up to 75 lbs.

A/V Capacity

Accommodates at least 4 audio/video components

Versatile Design

Versatile design allows user to display a TV in **three different ways**:

1. On the included wall mount
2. On the included swivel mounting pole
3. Simply placed on the stand

CMS® Cable Management System

An integrated CMS® Cable Management system to hide and route unsightly wire and cables

Easy Assembly

Easy-to-assemble, includes an owner's manual and easy-to-follow instructions

Open Architecture Design

Provides plenty of air circulation for convection cooling of components

Tempered Safety Glass

Elegant, tinted, tempered safety glass top and shelves

Warranty

1 year limited warranty

AVAILABLE FINISHES



Dark Cherry Finish



Mounted on wall included mount

Mounted on swivel pole, swivel pole included

Placed on the stand



WAVS99144

Bell'O
simply...beautiful®

TV Stand for TVs up to 47"



44"W X 20"D X 28"H



DARK
ESPRESSO
FINISH

WAVS99144



FEATURES

TV Capacity

Accommodates most flat screen TVs up to 47" or up to 45 lbs.

A/V Capacity

Accommodates at least 6 audio/video components

CMS® Cable Management System

An integrated CMS® Cable Management system to hide and route unsightly wire and cables

Assembles in Minutes

Assembles in minutes with no tools required

2 Display Cabinets

Display storage with tinted glass doors

Measures: 17.5"W X 16.75"D

Tinted Tempered Safety Glass Door Panels

Help hide clutter while allowing for operation of remote controls

Adjustable Shelves

Shelves are slotted for ventilation and can be readjusted or removed completely for added space

Exceptional Quality

Fine furniture quality construction and finish

Warranty

1 year limited warranty

AVAILABLE FINISHES



Dark Espresso Finish

WAVS99152

Bell'O
simply...beautiful®

TV Stand for TVs up to 55"



52"W X 20"D X 28.25"H



DARK
ESPRESSO
FINISH

WAVS99152



FEATURES

TV Capacity

Accommodates most flat screen TVs up to 55" or up to 55 lbs.

A/V Capacity

Accommodates at least 6 audio/video components

CMS® Cable Management System

An integrated CMS® Cable Management system to hide and route unsightly wire and cables

Assembles in Minutes

Assembles in minutes with no tools required

2 Display Cabinets

Display storage with tinted glass doors

Measures: 21.375"W X 16.75"D

Tinted Tempered Safety Glass Door Panels

Help hide clutter while allowing for operation of remote controls

Adjustable Shelving

Shelves are slotted for ventilation and can be readjusted or removed completely for added space

Exceptional Quality

Fine furniture quality construction and finish

Warranty

1 year limited warranty

AVAILABLE FINISHES



WAVS99163

Bell'O
simply...beautiful®

TV Stand for TVs up to 70"



63"W X 20"D X 28"H



DARK
ESPRESSO
FINISH

WAVS99163



Tinted Glass Wood
Frame Doors



CMS® Cable
Management System



Adjustable Wood
Shelves

FEATURES

TV Capacity

Accommodates most flat screen TVs up to 70" or up to 105 lbs.

A/V Capacity

Accommodates at least 6 audio/video components

CMS® Cable Management System

An integrated CMS® Cable Management system to hide and route unsightly wire and cables

Assembles in Minutes

Assembles in minutes with no tools required

2 Display Cabinets

Display storage with tinted glass doors

Measures: 21.375"W X 16.75"D

Tinted, Tempered, Safety Glass Door Panels

Help hide clutter while allowing for operation of remote controls

Adjustable Shelving

Shelves are slotted for ventilation and can be readjusted or removed completely for added space

Exceptional Quality

Fine furniture quality construction and finish

Warranty

1 year limited warranty

AVAILABLE FINISHES



Dark Espresso Finish

WMFC503

Bell'O
simply...beautiful®

TV Stand for TVs up to 55"



50"W X 19"D X 28"H

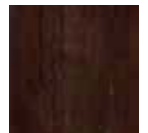

DEEP
MAHOGANY
FINISH

WMFC503



FEATURES

TV Capacity

Accommodates most flat screen TVs up to 55" or up to 55 lbs.

A/V Capacity

Accommodates at least 6 audio/video components

CMS® Cable Management System

An integrated CMS® Cable Management system to hide and route unsightly wire and cables

Assembles in Minutes

Assembles in minutes with no tools required

2 Display Cabinets

Display storage with tinted glass doors

Measures: 48.5"W X 16.5"D

Tinted, Tempered, Safety Glass Doors

Help hide clutter while allowing for operation of remote controls

Tempered, Safety Glass

Elegant, black tempered safety glass top and shelves

Exceptional Quality

Fine furniture quality construction and finish

Warranty

1 year limited warranty

AVAILABLE FINISHES



Deep Mahogany Finish

WMFC504

Bell'O
simply...beautiful®

TV Stand for TVs up to 50"



46"W X 19"D X 24"H



COCOA &
BLACK MATTE
FINISH

WMFC504



FEATURES

TV Capacity

Accommodates most flat screen TVs up to 50" or up to 45 lbs.

A/V Capacity

Accommodates at least 4 audio/video components

CMS® Cable Management System

An integrated CMS® Cable Management system to hide and route unsightly wire and cables

Assembles in Minutes

Assembles in minutes with no tools required

2 Display Cabinets

Display storage with tinted glass doors
Measures 44.75"W x 16.75"D

Tinted, Tempered, Safety Glass Doors

Help hide clutter while allowing for operation of remote controls

Tempered Safety Glass

Elegant black tempered safety glass top and shelves

Exceptional Quality

Fine furniture quality construction and finish

Warranty

1 year limited warranty

AVAILABLE FINISHES



Cocoa & Black Matte Finish

WMFC505

Bell'O
simply...beautiful®

TV Stand for TVs up to 55"



50"W X 19"D X 28"H

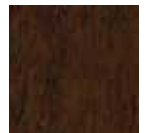

CHOCOLATE
FINISH

WMFC505



FEATURES

TV Capacity

Accommodates most flat screen TVs up to 55" or up to 100 lbs.

A/V Capacity

Accommodates at least 4 audio/video components

CMS® Cable Management System

An integrated CMS® Cable Management system to hide and route unsightly wire and cables

Assembles in Minutes

Assembles in minutes with no tools required

2 Display Cabinets

Display storage with tinted glass doors
Measures 44.75"W x 16.75"D

Tinted Tempered Safety Glass Doors

Help hide clutter while allowing for operation of remote controls

Tempered Safety Glass

Elegant black tempered safety glass top and shelves

Exceptional Quality

Fine furniture quality construction and finish

Warranty

1 year limited warranty

AVAILABLE FINISHES



Chocolate Finish

WMFC602

Bell'O
simply...beautiful®

TV Stand for TVs up to 70"



63"W X 20"D X 28"H

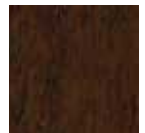

CHOCOLATE
FINISH

WMFC602



Slotted Doors
with Tinted Glass



Pass Through Holes
for Easy Wire
Management



Tinted Tempered
Safety Glass Shelves

FEATURES

TV Capacity

Accommodates most flat screen TVs up to 70" or up to 105 lbs.

A/V Capacity

Accommodates at least 4 audio/video components

CMS® Cable Management System

An integrated CMS® Cable Management system to hide and route unsightly wire and cables

Assembles in Minutes

Assembles in minutes with no tools required

2 Display Cabinets

Display storage with tinted glass doors
Measures 44.75"W x 16.75"D

Tinted Tempered Safety Glass Door Panels

Help hide clutter while allowing for operation of remote controls

Tempered Safety Glass

Elegant black tempered safety glass top and shelves

Exceptional Quality

Fine furniture quality construction and finish

Warranty

1 year limited warranty

AVAILABLE FINISHES



Chocolate Finish

ENTERPRISE

COLLECTION

Bell'O
simply...beautiful®

Furniture Collection



sound by
bell'o digital

BELL'O DIGITAL SPEAKERS

Built-in Bell'O Digital® sound system provides premium audio to fill even the largest rooms with stunning audio

Bluetooth®

WIRELESS AUDIO STREAMING

Wirelessly stream audio from any Bluetooth® enabled device directly to the sound bar

AVAILABLE WITH & WITHOUT SOUND BAR



HIGH GLOSS
BLACK FINISH



HIGH GLOSS
WHITE FINISH



HIGH GLOSS
CHERRY FINISH

ENTERPRISE

COLLECTION

COMBINE TO CREATE YOUR OWN PIER



ClassicFlame® **A-ELECTRIC FIREPLACE + SOUND**



D-DISPLAY CABINET TOP UNIT



ClassicFlame® **B-ELECTRIC FIREPLACE**



ClassicFlame® **C-TV STAND**



E



F

BASE UNIT OPTIONS



YOUR COMPLETE PIER

FEATURES

A. TV Stand w/ Electric Fireplace + Sound

26MMS9856 | 26MMS9864 | 26MMS9872

Bell'O Digital speakers, Bluetooth® audio streaming, A/V hookups, 2 side cabinets w/ adjustable shelving and touch-latch smoked glass doors, integrated wire management

B. TV Stand w/ Electric Fireplace

26MM9856 | 26MM9864 | 26MM9872

Partitioned full length media shelf, 2 side cabinets w/ adjustable shelving and touch-latch smoked glass doors, integrated wire management

C. TV Stand TC60-9616-NB03

Partitioned full length media shelf, 2 side cabinets w/ adjustable shelving and touch-latch smoked glass doors, integrated wire management

D. Left or Right Display Cabinet (Top) EC9822-US22

Storage cabinet, touch-latch Smoked glass doors, 3-level LED touch lighting, adjustable shelving

E. Beverage Cooler (Base) EC9822-LC22

Thermoelectric beverage cooler, vibration-free thermoelectric cooling, whisper quiet operation

F. Left or Right Storage Cabinet (Base) EC9822-LS22

Storage cabinet, adjustable shelving, integrated wire management

Easy Assembly

Simple, hassle-free assembly with just a Phillips head screwdriver,

includes an owner's manual and easy-to-follow instructions



AVAILABLE FINISHES



High Gloss Black Finish (NB03)



High Gloss White Finish (NT01)



High Gloss Cherry Finish (NC10)

POSSIBLE PIER COMBINATIONS

BEVERAGE PIER | EC9822LC22 + EC9822US22

STORAGE PIER | EC9822LS22 + EC9822US22

The Bluetooth® word mark and logos are registered trademarks owned by Bluetooth SIG, Inc. and any use of such marks by Twin-Star, International is under license. Other trademarks and trade names are those of their respective owners.

ENTERPRISE

EC9822-US

Bell'O
simply...beautiful®

Universal Upper Storage Unit



21.5"W X 22.5"D X 47.75"H



HIGH GLOSS
BLACK FINISH



HIGH GLOSS
WHITE FINISH



HIGH GLOSS
CHERRY FINISH

ENTERPRISE

EC9822-US



Display Cabinet with
Tempered Glass Framed
Door Panels



Interior LED Lighting



Adjustable Shelving

FEATURES

Easy Assembly

Simple, hassle-free assembly with just a Phillips head screwdriver, includes an owner's manual and easy-to-follow instructions

3-Level LED Touch Lighting

LED touch lighting top illuminates contents and provides attractive display lighting

CMS® Cable Management System

An integrated CMS® Cable Management system to hide and route unsightly wire and cables

Touch-Latch, Smoked Glass Door

Sleek, minimalistic door open with just a touch

Adjustable Shelves

Shelves can be readjusted or removed completely for added space

Reversible Door

Door can be mounted on the left or right side

Soft Close European Hinges

Concealed, soft close, 3-way adjustable euro hinges

Architectural Detailing

Contemporary style with high gloss finish

AVAILABLE FINISHES



High Gloss Black Finish
(NB03)



High Gloss White Finish
(NT01)



High Gloss Cherry Finish (NC10)

Bell'O
simply...beautiful®

ENTERPRISE

EC9822-LC22

Bell'O
simply...beautiful®

Beverage Cooler



21.5"W X 22.5"D X 30"H



HIGH GLOSS
BLACK FINISH



HIGH GLOSS
WHITE FINISH



HIGH GLOSS
CHERRY FINISH

ENTERPRISE

EC9822-LC22



Can & Bottle Storage

Adjustable Shelf

FEATURES

Easy Assembly

Simple, hassle-free assembly with just a Phillips head screwdriver; includes an owner's manual and easy-to-follow instructions

Architectural Detailing

Contemporary style with high gloss finish and metal base

Beverage Cooler

Thermoelectric beverage cooler, vibration-free cooling, whisper-quiet operation

Door Storage

Store bottles and cans on the door for easy access

AVAILABLE FINISHES



High Gloss Black Finish (NB03)



High Gloss White Finish (NT01)



High Gloss Cherry Finish (NC10)

Bell'O
simply...beautiful®

ENTERPRISE

EC9822-LS22

Bell'O
simply...beautiful®

Lower Storage Unit



21.5"W X 22.5"D X 30"H



HIGH GLOSS
BLACK FINISH



HIGH GLOSS
WHITE FINISH



HIGH GLOSS
CHERRY FINISH

ENTERPRISE

EC9822-LS22



Soft Close Euro Hinges

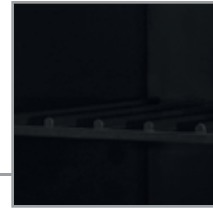

Adjustable, Reversible Shelving

FEATURES

Easy Assembly

Simple, hassle-free assembly with just a Phillips head screwdriver, includes an owner's manual and easy-to-follow instructions

Architectural Detailing

Contemporary style with high gloss finish and metal base

Adjustable, Reversible Shelving

Reversible shelves (slotted for bottle storage or flat for display) can be readjusted or removed completely for added space

Soft Close European Hinges

Concealed, soft close, 3-way adjustable euro hinges

AVAILABLE FINISHES



High Gloss Black Finish



High Gloss White Finish



High Gloss Cherry Finish

WESLEYAN

COLLECTION - EC6449

Bell'O
simply...beautiful®

Furniture Collection



MERIDIAN
CHERRY
FINISH

WESLEYAN

COLLECTION 6449

COMBINE TO CREATE YOUR OWN PIER

sound by
bellódigital®



ClassicFlame™ **ELECTRIC FIREPLACE + MEDIA**



C-TOP UNIT



TV STAND



D F E
BASE UNIT OPTIONS



YOUR COMPLETE PIER

FEATURES

A. TV Stand w/ Electric Fireplace 32MM6449-C247

Full length media shelf w/ recessed partition for sound bar installation, 2 side cabinets, adjustable wood shelving, soft close european hinges, integrated wire management

B. TV Stand TC60-6449-C247

Full length media shelf w/ recessed partition for sound bar installation, CMS® Cable Management System. 2 display cabinets, adjustable wood shelving

C. Display Cabinet EC6449US22-C247

Wood-framed glass door, 3-level LED touch lighting, flip-down work surface, adjustable glass shelving

E. Beverage Cooler (Base) EC6449LC22-C247

Thermoelectric beverage cooler, vibration-free thermoelectric cooling, whisper quiet operation, storage drawer

F. Left or Right Storage Cabinet (Base) EC6449LS22-C247

Wood-framed glass door, adjustable wood shelving, soft close european hinges, CMS® Cable Management System

G. Wine Cooler (Base) EC6449RW22-C247

18-bottle, dual-zone wine cooler; vibration-free, thermoelectric cooling; whisper quiet operation; secure lock & key wine storage; slide-out, chrome-plated wine racks

Easy Assembly

Simple, hassle-free assembly with just a Phillips head screwdriver, includes an owner's manual and easy-to-follow instructions

AVAILABLE FINISHES



Meridian Cherry Finish (C247)



POSSIBLE PIER COMBINATIONS

BEVERAGE PIER | EC6449LC22-C247 + EC6449US22-C247

STORAGE PIER | EC6449LS22-C247 + EC6449US22-C247

WINE PIER | EC6449RW22-C247 + EC6449US22-C247

WESLEYAN

TC60-6449-C247

Bell'O
simply...beautiful®

TV Stand for TVs up to 65"



59.5"W X 19"D X 35.75"H



MERIDIAN
CHERRY
FINISH

WESLEYAN

TC60-6449-C247



Partitioned Media Shelf w/
CMS® Cable Management
System



Cabinets with
Adjustable Shelves



Display Cabinet with
Wood-Framed Glass Doors

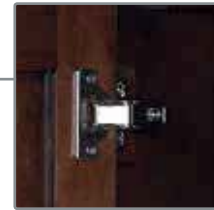

Soft Close Euro Hinges

FEATURES

TV Capacity

Accommodates most flat screen TVs up to 65" or up to 90 lbs

A/V Capacity

Accommodates at least 4 audio/video components

CMS® Cable Management System

An integrated CMS® Cable Management system to hide and route unsightly wire and cables

Easy Assembly

Simple, hassle-free assembly with just a Phillips head screwdriver includes an owner's manual and easy-to-follow instructions

Architectural Detailing

Contemporary style with framed glass panel doors and metal base

Full Length Media Shelf with Recessed Partition

A perfect solution for media components and storage

Cabinets with Adjustable Shelves

Functional display storage with adjustable shelves

Soft Close European Hinges

Concealed, soft close, 3-way adjustable euro hinges

AVAILABLE FINISHES



Meridian Cherry Finish (C247)

WESLEYAN

EC6449LC22-C247 + EC6449US22-C247

Bell'O
simply...beautiful®

Beverage Pier



TOP: 21.5"W X 22.5"D X 44.5"H

BASE: 21.5"W X 22.5"D X 35.75"H

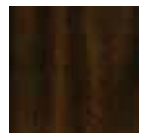

MERIDIAN
CHERRY
FINISH

WESLEYAN

EC6449LC22-C247 + EC449US22-C247



FEATURES

Easy Assembly

Simple, hassle-free assembly with just a Phillips head screwdriver; includes an owner's manual and easy-to-follow instructions

CMS® Cable Management System

An integrated CMS® Cable Management system to hide and route unsightly wire and cables

Architectural Detailing

Contemporary style with metal base

Display Cabinet with Adjustable Shelves (Top)

EC6449LC22-C247

Functional storage with adjustable glass shelves

Flip-Down Work Surface

Convenient, flip-down shelf with black glass insert

Interior LED Lighting

Concealed, interior LED lighting

Soft Close European Hinges

Concealed, soft close, 3-way adjustable euro hinges

Beverage Cooler (Base)

EC6449LC22-C247

Thermoelectric beverage cooler, vibration-free cooling, whisper quiet operation, storage drawer

AVAILABLE FINISHES



Meridian Cherry Finish (C247)

WESLEYAN

EC6449LC22-C247 + EC449US22-C247

Bell'O
simply...beautiful®

Wine Pier



TOP: 21.5"W X 22.5"D X 44.5"H
BASE: 21.5"W X 22.5"D X 35.75"H



MERIDIAN
CHERRY
FINISH

WESLEYAN

EC6449LC22-C247 + EC449RW22-C247



FEATURES

Easy Assembly

Simple, hassle-free assembly with just a Phillips head screwdriver; includes an owner's manual and easy-to-follow instructions

CMS® Cable Management System

An integrated CMS® Cable Management system to hide and route unsightly wire and cables

Architectural Detailing

Contemporary style with metal base

Display Cabinet with Adjustable Shelves (Top)

EC6449LC22-C247

Functional storage with adjustable glass shelves

Flip-Down Work Surface

Convenient, flip-down shelf with black glass insert

Interior LED Lighting

Concealed, interior LED lighting

Wine Cooler (Base)

EC6449RW22-C247

18-bottle dual-zone wine cooler; vibration-free cooling; whisper quiet operation; secure lock & key wine storage; slide-out, chrome-plated wine racks

Soft Close European Hinges

Concealed, soft close, 3-way adjustable euro hinges

AVAILABLE FINISHES



Meridian Cherry Finish (C247)

Bell'O
simply...beautiful®

WESLEYAN

EC6449LS22-US22

Bell's
simply...beautiful®

Beverage Cooler



21.5"W X 22.5"D X 35.75"H

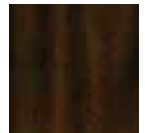

MERIDIAN
CHERRY
FINISH

WESLEYAN

EC6449LS22-US22



FEATURES

Easy Assembly

Simple, hassle-free assembly with just a Phillips head screwdriver, includes an owner's manual and easy-to-follow instructions

Architectural Detailing

Contemporary style with a metal base

Beverage Cooler

Thermoelectric beverage cooler, vibration-free cooling, whisper quiet operation

Storage Drawer

Smooth glide storage drawer

Door Storage

Store bottles and cans on the door for easy access

AVAILABLE FINISHES



Meridian Cherry Finish (C247)

WESLEYAN

EC6449RW22-C247

Bell'O
simply...beautiful®

Wine Cooler



21.5"W X 22.5"D X 35.75"H

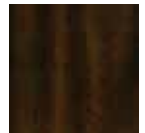

MERIDIAN
CHERRY
FINISH

WESLEYAN

EC6449RW22-C247



FEATURES

Easy Assembly

Simple, hassle-free assembly with just a Phillips head screwdriver; includes an owner's manual and easy-to-follow instructions

Architectural Detailing

Contemporary style with metal base

Wine Cooler

EC6449RW22-C247

18-Bottle dual-zone wine cooler, vibration-free thermoelectric cooling, whisper quiet operation

Secure Lock and Key

Locking cooler to safeguard beverages

Chrome Plated Wine Racks

Slide out chrome-plated wine racks

AVAILABLE FINISHES



Meridian Cherry Finish (C247)

METRO

BC2426-E451-31

Bell'O
simply...beautiful®

Bar Cabinet



31.5"W X 16"D X 55"H



ESPRESSO
FINISH

METRO

BC2426-E451-31

Extra Tall, Mirror-Backed
Cabinets w/ Cork Shelf Lining



Secure Lock & Key



In-Door Bottle Storage



Cabinets Rotate Open
in One Motion

FEATURES

Extra-Tall Liquor Bottle Storage

Shelves are designed to fit extra tall/ bottles

3-Tiered Center Shelving

Half-round, display shelving for bottle storage

3-Tiered In-Door Storage

In-door storage provides extra space

Secure Lock & Key

Cabinet locks to safeguard your beverages

Revolving Doors

Center and side cabinets simultaneously rotate open for full display with a gentle pull

Architectural Detailing

Mirror-backed cabinets, brushed stainless steel bottle guards, cork shelf lining, shadow-line details, Brushed Nickel hardware

Easy Assembly

Simple, hassle-free assembly with just a Phillips head screwdriver, includes an owner's manual and easy-to-follow instructions

AVAILABLE FINISHES



Espresso Finish (E451)

LOUIE

CC30-9643

Bell'O
simply...beautiful®

Curio Cabinet



30"W X 15"D X 78.5"H



BLACK
FINISH



CHERRY
FINISH

LOUIE

CC30-9643

3-Level LED
Touch Lighting



Adjustable Glass
Display Shelving



Touch-Latch, Glass
Side-Access Doors



Hidden Storage
Compartment

FEATURES

Mirror-Backed Cabinet

Mirror-backed display cabinet adds a touch of sparkle and creates the illusion of more space
Measures: 25.75"W X 12"D X 64.5"H

Adjustable Glass Display Shelves

5 glass display shelves can be readjusted or removed completely for added space

Touch-Latch Side Doors

4 glass doors open with just a touch allowing convenient access from both sides

Hidden Storage Compartment

Concealed storage space in the base of the curio
Measures: 25.5"W X 10.5"D X 2.5"H

3-Level LED Touch Lighting

LED touch lighting inside top cabinet illuminates contents and provides attractive display lighting

Architectural Detailing

5mm glass display cabinet with magnetic door catches

Easy Assembly

Easy-to-assemble with just a Phillips head screwdriver includes an owner's manual and easy-to-follow instructions

Exceptional Quality

Fine furniture quality construction and finish

Warranty

1 year limited warranty

AVAILABLE FINISHES



Black Finish (X334)



Cherry Finish (X331)

Bell'O
simply...beautiful®

MAYFIELD

CC30-9654-X332

Bell'O
simply...beautiful®

Curio Cabinet



30"W X 14"D X 78"H



CHERRY
FINISH

MAYFIELD

CC30-9654-X332



FEATURES

Mirror-Backed Cabinet

Mirror-backed display cabinet adds a touch of sparkle and creates the illusion of more space
Measures: 27"W X 11.25"D X 65.25"H

Adjustable Glass Display Shelving

4 glass display shelves can be readjusted or removed completely for added space

Wood-Framed Sliding Glass Door

Wood-framed glass door slides left or right on steel ball bearing glides for full frontal access

Hidden Storage Compartment

Concealed storage space in the base of the curio
Measures: 25.5"W X 10.5"D X 2.5"H

3-Level LED Touch Lighting

LED touch lighting inside top cabinet illuminates contents and provides attractive display lighting

Architectural Detailing

5mm glass display cabinet and exposed metal accents

Easy Assembly

Easy-to-assemble with just a Phillips head screwdriver includes an owner's manual and easy-to-follow instructions

Exceptional Quality

Fine furniture quality construction and finish

Warranty

1 year limited warranty

AVAILABLE FINISHES



Cherry Finish (X332)

Bell'O
simply...beautiful®

THORNTON

CC34-3861-1622

Bell's
simply...beautiful®

Curio Cabinet with Wine Storage



34"W X 14"D X 78"H



WAXY WEATHERED
GRAY FINISH

THORNTON

CC34-3861-I622

3-Level LED
Touch Lighting



Adjustable Glass
Display Shelving



16 Bottle Storage



FEATURES

Adjustable Glass Display Shelving

5 glass display shelves can be readjusted or removed completely for added space

Reversible Shelving

Use slotted side for bottle storage or flat side for display

Touch-Latch Side-Access Doors

Glass doors open with just a touch allowing convenient access

Wine Storage

16 wine bottles with beveled glass

Side Storage

Easily read labels and store up to 16 wine bottles on the side storage racks

3-Level LED Touch Lighting

LED touch lighting inside top cabinet illuminates contents and provides attractive display lighting

Architectural Detailing

5mm glass display cabinet and magnetic door catches

Easy Assembly

Easy-to-assemble with just a Phillips head screwdriver includes an owner's manual and easy-to-follow instructions

Exceptional Quality

Fine furniture quality construction and finish

Warranty

1 year limited warranty

AVAILABLE FINISHES



Waxy Weathered Gray Finish (I622)

Bell's
simply...beautiful®

BOOMERANG

CC32-6989-X144

Bell'O
simply...beautiful®

Curio Cabinet



31.5"W X 15.5"D X 78"H

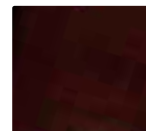

DEEP
ESPRESSO
FINISH

BOOMERANG

CC32-6989-X144



FEATURES

Mirror-Backed Cabinet

Mirror-backed display cabinet adds a touch of sparkle and creates the illusion of more space
Measures: 25.75"W X 12"D X 64.5"H

Adjustable Glass Display Shelving

4 glass display shelves can be readjusted or removed completely for added space

Touch-Latch Side-Access Doors

4 glass doors open with just a touch allowing convenient access from both sides

Hidden Storage Compartment

Concealed storage space in the base of the curio
Measures: 24"W X 9.5"D X 2"H

3-Level LED Touch Lighting

LED touch lighting inside top cabinet illuminates contents and provides attractive display lighting

Architectural Detailing

5mm glass display cabinet and magnetic door catches

Easy Assembly

Easy-to-assemble with just a Phillips head screwdriver includes an owner's manual and easy-to-follow instructions

Exceptional Quality

Fine furniture quality construction and finish

Warranty

1 year limited warranty

AVAILABLE FINISHES



Deep Espresso Finish (X144)

Bell'O
simply...beautiful®

CD8841

Bell'O
simply...beautiful®

Computer Desk



47"W X 24"D X 30"H



VIBRANT
ESPRESSO
FINISH

CD8841



FEATURES

Vibrant Espresso Finish

Elegant black chrome posts with curved sides in Vibrant Espresso

Tempered Safety Glass

Elegant clear tempered safety glass top and shelves

CMS® Cable Management System

An integrated CMS® Cable Management system to hide and route unsightly wire and cables

Easy Assembly

Easy-to-assemble with just a Phillips head screwdriver includes an owner's manual and easy-to-follow instructions

Exceptional Quality

Fine furniture quality construction and finish

Warranty

1 year limited warranty

AVAILABLE FINISHES



Vibrant Espresso Finish

CD8855

Bell'O
simply...beautiful®

Computer Desk



31.5"W X 21.75"D X 30.25"H



HIGH GLOSS
BLACK FINISH

CD8855

Sleek and
Modern Design



Tinted Tempered
Safety Glass Shelves



High Gloss
Black Finish



Slide-Out
Keyboard Tray

FEATURES

High Gloss Black

Scratch resistant, powder-coated metal frame

Tempered Safety Glass

Elegant, clear, tempered safety glass top and shelves

Easy Assembly

Easy-to-assemble with just a Phillips head screwdriver
includes an owner's manual and easy-to-follow instructions

Pull-Out Keyboard Tray

Keyboard tray slides out for easy access

Exceptional Quality

Fine furniture quality construction and finish

Warranty

1 year limited warranty

AVAILABLE FINISHES



High Gloss Black Finish

TECH

OD10205-48

Bell'O
simply...beautiful®

Office Desk



47.25"W X 23.75"D X 28.75"H



WHITE
FINISH



BLACK
FINISH

TECH

OD10205-48

Pencil Drawer with
Partitions for Organization



6mm Glass Desktop



Brushed Nickel
Mounting Supports



Anodized Aluminum
Construction

FEATURES

Glass Desktop

6mm glass desktop provides even writing surface and protects against transfer from pens and pencils

Pullout Pencil Drawer

Features partitions for easy organization of office supplies

Anodized Aluminum

Contemporary style, lasting durability and simple upkeep with mild soap and water to clean

Easy Assembly

Easy-to-assemble with just a Phillips head screwdriver, includes an owner's manual and easy-to-follow instructions

Exceptional Quality

Fine furniture quality construction and finish

Warranty

1 year limited warranty

AVAILABLE FINISHES



White Finish (WHT)



Black Finish (BLK)

ENTERPRISE

ODS4915-48

Bell'O
simply...beautiful®

Office Desk



 **Bluetooth®**
sound by
bell'o digital

47.5"W X 23.5"D X 33.75"H

HIGH GLOSS
BLACK FINISH

HIGH GLOSS
WHITE FINISH

HIGH GLOSS
CHERRY FINISH

ENTERPRISE

ODS4915-48



FEATURES

Glass Desktop

5mm glass desktop provides even writing surface and protects against transfers from pens or pencils

Stereo Speakers w/Aux Input

Left and right stereo speakers (56 watts), angled up toward the user, provide optimal audio; auxiliary input for direct audio playback

Bluetooth® Audio Streaming

Stream audio from any Bluetooth® enabled device directly to the speakers

2-Outlet & 2-Port USB Power Supply

Provides direct power with 2 outlets and 2 USB power ports

Touch-Latch Pencil Drawer

Features partitions for easy organization of office supplies

Side Storage Cabinet

Functional storage with a fixed shelf and filing drawer
Measures: 12.5"W X 20"D X 25.5"H

Touch-Latch Smoked Glass Door

Sleek, minimalistic smoked glass door opens with just a touch

Easy Assembly

Easy-to-assemble with just a Phillips head screwdriver, includes an owner's manual and easy-to-follow instructions

Exceptional Quality

Fine furniture quality construction and finish

Warranty

1 year limited warranty

AVAILABLE FINISHES



High Gloss White Finish (NT01)



High Gloss Black Finish (NB03)



High Gloss Cherry Finish (NC10)

Bell'O
simply...beautiful®

TPC2143

Bell'O
simply...beautiful®

Triple Play™ Universal Flat Panel A/V System for TVs up to 55"



44"W X 21.25"D X 56.5"H



VIBRANT
ESPRESSO
FINISH

TPC2143



Tinted Tempered Safety Glass Shelves

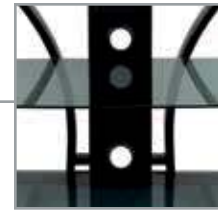

CMS® Cable Management System

FEATURES

TV Capacity

Accommodates most flat screen TVs up to 55" or up to 55 lbs.

A/V Capacity

Accommodates at least 4 audio/video components

Versatile Design

Versatile design allows user to display a TV in **three different ways**:

1. On the included wall mount
2. On the included swivel mounting pole
3. Simply placed on the stand

CMS® Cable Management System

An integrated CMS® Cable Management system to hide and route unsightly wire and cables

Easy Assembly

Easy-to-assemble, includes an owner's manual and easy-to-follow instructions

Open Architecture Design

Provides plenty of air circulation for convection cooling of components

Tempered Safety Glass

Elegant, tinted, tempered safety glass top and shelves

Warranty

1 year limited warranty

AVAILABLE FINISHES



Vibrant Espresso Finish



Mounted on wall included mount



Mounted on swivel pole, swivel pole included



Placed on the stand

WMFC602

Bell'O
simply...beautiful®

TV Stand for TVs up to 70"



63"W X 20"D X 28"H



CHOCOLATE
FINISH

WMFC602



Tinted Glass
Slotted Doors



CMS® Cable
Management System



Tinted Tempered Safety
Glass Shelves

FEATURES

TV Capacity

Accommodates most flat screen TVs up to 70" or up to 105 lbs.

A/V Capacity

Accommodates at least 4 audio/video components

CMS® Cable Management System

An integrated CMS® Cable Management system to hide and route unsightly wire and cables

Assembles in Minutes

Assembles in minutes with no tools required

2 Display Cabinets

Display storage with tinted glass doors
Measures 44.75"W x 16.75"D

Tinted, Tempered Safety Glass Doors

Help hide clutter while allowing for operation of remote controls

Tempered Safety Glass

Elegant black tempered safety glass top and shelves

Exceptional Quality

Fine furniture quality construction and finish

Warranty

1 year limited warranty

AVAILABLE FINISHES



Chocolate Finish

2015



Audio Video Accessories

Surround Sound Shelves

Headphones

TV Wall Mounts

Power Surge Protectors

HDMI & A/V Cables

Audio Video Accessories



Surround Sound Shelves



Features

- Bluetooth® wireless technology
- 4 Professionally tuned speaker drivers
- Learning remote capability
- Amplifier - Voice boost, bass boost & surround sound
- Easy wall mounting - All mounting hardware is included



At first glance it's an attractive wooden shelf, but what meets the eye can be deceiving. Discretely hidden behind it's beautiful exterior is a professionally engineered sound system. The high-output, Class-D amplifier, professionally tuned speaker drivers and large sound cavity provides the perfect dynamic for a rewarding listening experience. Add the optional Bell'O Digital wireless subwoofer to pump it up to an earth-shattering, cinema style experience.

Available in 3 sizes



4 Professionally tuned speaker drivers



MODEL	DESCRIPTION	COLOR	SIZE
BDS4012-40-E474	40" Surround Sound Shelf	Dark Espresso	40"L x 12"D x 7-3/4"H
BDS4012-50-E474	50" Surround Sound Shelf	Dark Espresso	50"L x 12"D x 7-3/4"H
BDS4012-60-E474	60" Surround Sound Shelf	Dark Espresso	60"L x 12"D x 7-3/4"H

Headphones

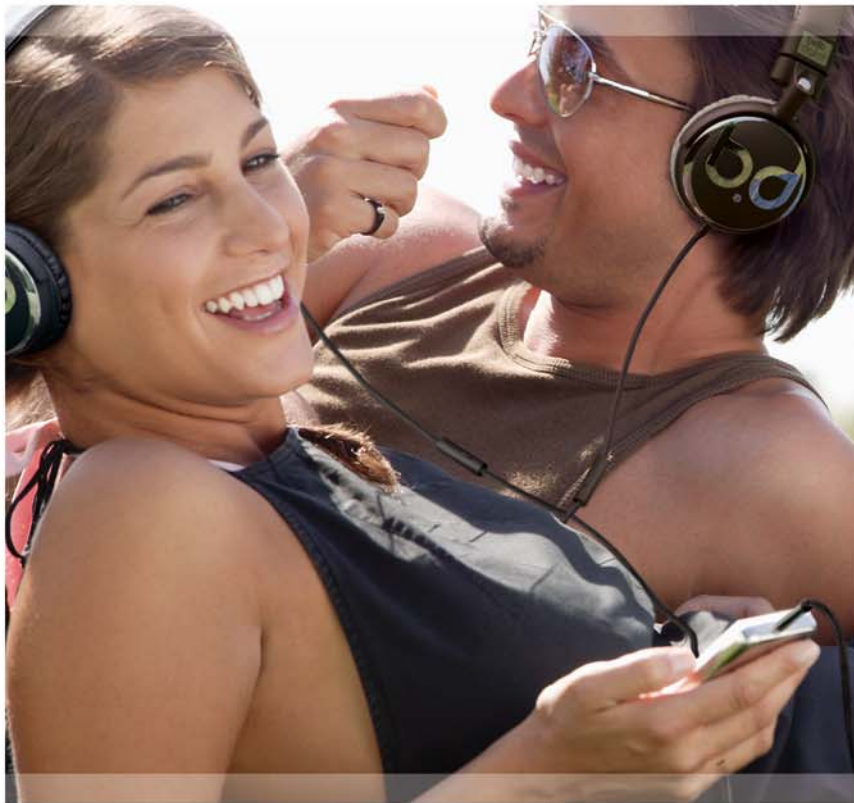



What's included

- One pair of in-ear headphones
- 3 sizes of soft, durable silicone ear buds - providing a custom fit and noise isolation

Features

- Dynamic bass
- Lightweight design using low mass polymer construction
- Tangle resistant cable engineered to be durable, flexible and lightweight
- 99% Oxygen free copper wire provides extraordinary signal transfer resulting in amazing sound
- 24K Gold-plated plug assures optimal connectivity
- Strain relief and internal fabric support



Color options



Frequency Response:
20Hz to 20,000Hz
Cable Type: TPE
Cable Length: 4 Ft. (1.2m)
Plug Type: 3.5 mm

Compatible with iPod®, iPhone® and iPad®.
Also compatible with Android™ Devices and other electronic devices using a 3.5mm headphone port.



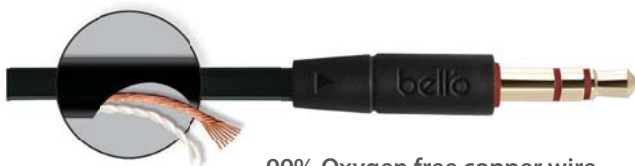

99% Oxygen free copper wire with fabric reinforced cable

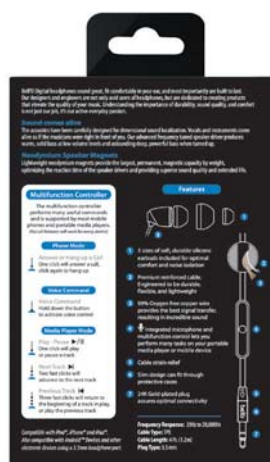

What's Included

- One pair of in-ear headphones
- 3 sizes of soft, durable silicone ear buds - providing a custom fit and noise isolation

Features





- In-line multifunction controller with microphone*
- Precision bass
- Lightweight design using low mass metal and polymer construction
- Premium flat cable engineered to be durable, flexible, lightweight, and tangle-free
- 99% Oxygen free copper wire provides extraordinary signal transfer resulting in amazing sound
- 24K Gold-plated plug assures optimal connectivity
- Strain relief and fabric reinforced cable for strength

In-line multifunction controller with microphone*

The integrated microphone provides superb sound quality for your listener. The bonus one-touch button lets you accept and hang up phone calls, play and pause music, access and use the voice control function and track advance/track back on most Apple, Blackberry, Android phones and portable media players.



Color Options

<p>Deep Red & Chrome</p>  <p>BDH441RD</p>	<p>Chrome & Matte Black</p>  <p>BDH441CHR</p>
<p>Piano White & Chrome</p>  <p>BDH441WH</p>	<p>Matte Black & Chrome</p>  <p>BDH441BK</p>

Frequency Response: 20Hz to 20,000Hz
 Cable Type: TPE
 Cable Length: 4 Ft. (1.2m)
 Plug Type: 3.5 mm

*Works with most Apple®, Android™, and BlackBerry® devices. Compatible with iPod®, iPhone® and iPad®. Also compatible with other electronic devices using a 3.5mm headphone port.



99% Oxygen free copper wire with fabric reinforced cable



Soft travel bag

Protects and stores your headphones



What's included

- One pair of in-ear headphones
- 3 sizes of soft, durable silicone ear buds - providing a custom fit and noise isolation
- Soft, protective travel bag

Features

- In-line multifunction controller with microphone*
- Precision bass
- Lightweight design using low mass metal and polymer construction
- Premium flat cable engineered to be durable, flexible, lightweight, and tangle-free
- 99% Oxygen free copper wire provides extraordinary signal transfer resulting in amazing sound
- 24K Gold-plated plug assures optimal connectivity
- Strain relief and fabric reinforced cable for strength

In-line multifunction controller with microphone*

The integrated microphone provides superb sound quality for your listener. The bonus one-touch button lets you accept and hang up phone calls, play and pause music, access and use the voice control function and track advance/track back on most Apple, Blackberry, Android phones and portable media players.



Color options

Black Chrome & Copper



BDH641BCCP

Matte Black & Chrome



BDH641BK

Chrome & Midnight Blue



BDH641CHR

Piano White & Black Chrome



BDH641WH

Frequency Response: 20Hz to 20,000Hz
 Cable Type: TPE
 Cable Length: 4 Ft. (1.2m)
 Plug Type: 3.5 mm

*Works with most Apple®, Android™, and BlackBerry® devices. Compatible with iPod®, iPhone® and iPad®. Also compatible with other electronic devices using a 3.5mm headphone port.



Color options

Black Chrome & Copper



Piano White & Black Chrome



Dark Chrome & Matte Black



Black Chrome & Copper



Piano White & Black Chrome



Frequency Response: 20Hz to 20,000Hz
 Cable Type: TPE
 Cable Length: 4 Ft. (1.2m)
 Plug Type: 3.5 mm

*Works with most Apple®, Android™, and BlackBerry® devices. Compatible with iPod®, iPhone® and iPad®.

Also compatible with other electronic devices using a 3.5mm headphone port.

- What's included**
- One pair of in-ear headphones
 - 3 sizes of soft, durable silicone ear buds - providing a custom fit and noise isolation
 - Thin profile protective hard case

- Features**
- In-line multifunction controller with microphone* (BDH654 features Apple® remote control with microphone**)
 - In-line volume control
 - Precision bass
 - Lightweight design using low mass metal construction
 - Premium flat cable engineered to be durable, flexible, lightweight, and tangle-free
 - 99% Oxygen free copper wire provides extraordinary signal transfer resulting in amazing sound
 - 24K Gold-plated plug assures optimal connectivity
 - Strain relief and fabric reinforced cable for strength

In-line volume control
 A convenient sliding volume control is integrated into the cable. Engineered non-slip surface on the back for easy volume adjustment.



In-line multifunction controller with microphone

The integrated microphone provides superb sound quality for your listener. The bonus one-touch button lets you accept and hang up phone calls, play and pause music, access and use the voice control function and track advance/track back on most Apple, BlackBerry, Android phones and portable media players.



Apple® Remote Control With Microphone Features
 (Applies to BDH654 models only)

- Pause a song or video
- Skip to the next song
- Return to previous song
- Fast-forward or rewind
- Adjust the volume
- Answer an incoming call
- End the current call
- Decline an incoming call
- Switch to an incoming or on-hold call and put the current call on hold
- Switch to an incoming or on-hold call and end the current call
- Use Siri or Voice Control



**The remote and mic are supported only by iPod nano (4th generation or later), iPod classic (120GB, 160GB), iPod touch (2nd generation or later), iPhone 3GS or later, and iPad. The remote is supported by iPod shuffle (3rd generation or later). Audio is supported by all iPod models and iPad.

iPod®, iPhone®, iPad® are trademarks of Apple Inc., registered in the U.S. and other countries.



BDH251BK



Soft ear hook bends to fit around your ear

Adjustable slider for tangle prevention & removable shirt clip



Frequency Response: 20Hz to 20,000Hz
 Cable Type: TPE
 Cable Length: 4 Ft. (1.2m)
 Plug Type: 3.5 mm 24K Gold plated



What's included

- One pair of in-ear sport headphones
- 3 sizes of soft, durable silicone ear buds - providing a custom fit and noise isolation
- Removable shirt clip

Features

- Soft ear hook bends to fit around your ear
- Sweat resistant
- In-line multifunction controller with microphone*
- Precision bass
- Lightweight design using low mass metal construction
- Weight balanced, tangle resistant cable
- 99% Oxygen free copper wire provides extraordinary signal transfer resulting in amazing sound
- 24K Gold-plated plug assures optimal connectivity
- Strain relief and fabric reinforced cable for strength

In-line multifunction control with microphone*

The integrated microphone provides superb sound quality for your listener. The bonus one-touch button lets you accept and hang up phone calls, play and pause music, access and use the voice control function and track advance/track back on most Apple, Blackberry, Android phones and portable media players.



Color options

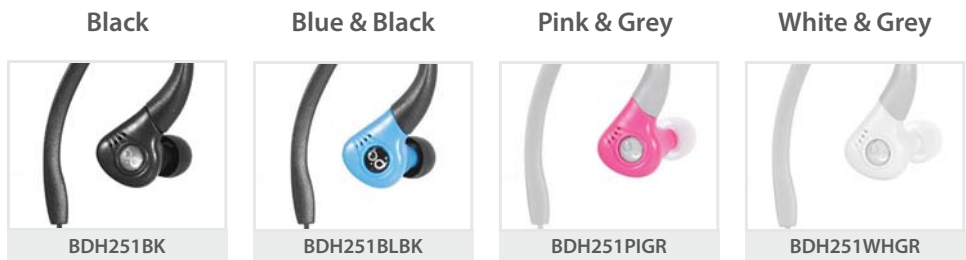

*Works with most Apple®, Android™, and BlackBerry® devices. Compatible with iPod®, iPhone® and iPad®. Also compatible with other electronic devices using a 3.5mm headphone port.



Soft ear hook bends to form a custom fit around your ear, and stays in place



Soft travel bag & removable shirt clip



What's included

- One pair of in-ear sport headphones
- 3 sizes of soft, durable silicone ear buds - providing a custom fit and noise isolation
- Soft protective travel bag
- Removable shirt clip

Features

- Soft ear hook bends to a custom fit around your ear
- Sweat resistant
- In-line multifunction controller with microphone*
- Precision bass
- Lightweight design using low mass metal construction
- Weight balanced, tangle resistant cable
- 99% Oxygen free copper wire provides extraordinary signal transfer resulting in amazing sound
- 24K Gold-plated plug assures optimal connectivity
- Strain relief and fabric reinforced cable for strength

In-line multifunction control with microphone*

The integrated microphone provides superb sound quality for your listener. The bonus one-touch button lets you accept and hang up phone calls, play and pause music, access and use the voice control function and track advance/track back on most Apple, Blackberry, Android phones and portable media players.



99% Oxygen free copper wire with fabric reinforced cable

Color options

Black & Dark Chrome



BDH751BDGP

Lime Green/Black & Chrome

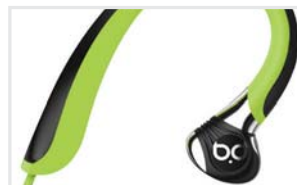

BDH751GDGP

Pink/Black & Chrome



BDH751PICP

*Works with most Apple®, Android™, and BlackBerry® devices. Compatible with iPod®, iPhone® and iPad®. Also compatible with other electronic devices using a 3.5mm headphone port.



Headphones fold flat or fold in for easy storage



What's included

- One pair of over-the-head headphones

Features

- In-line multifunction controller with microphone*
- Precision bass
- Premium flat cable is lightweight, durable, and tangle resistant
- Soft comfortable ear cushions
- Durable padded headband
- Lightweight design using low mass metal construction
- 99% Oxygen free copper wire provides extraordinary signal transfer resulting in amazing sound
- 24K Gold-plated plug assures optimal connectivity
- Strain relief and fabric reinforced cable for strength

In-line multifunction control with microphone*

The one button control performs many useful commands and is supported by most mobile phone and portable media players. Some devices may require you to click two times or to hold the button down for a few seconds to activate some commands. Not all features will work for every device. Refer to the user's manual for your device to see which features are supported. Please note that not all manuals list the one-touch button features, even though they are supported.



Frequency Response: 20Hz to 20,000Hz
 Cable Type: Flat, TPE
 Cable Length: 4' 4" (1.32 M)
 Plug Type: 3.5 mm

Color options



Black	White	Blue	Pink	Red
BDH806BK	BDH806WH	BDH806BL	BDH806PI	BDH806RD

*Works with most Apple® and Android™ devices. Compatible with iPod®, iPhone® and iPad®. Also compatible with other electronic devices using a 3.5mm headphone port.



What's included

- One pair of over-the-head headphones
- Microfiber travel bag

Features

- In-line multifunction controller with microphone*
- Precision bass
- Tangle-free fabric covered cable
- Soft, comfortable ear cushions
- Durable padded headband
- Lightweight design using low mass metal construction
- 99% Oxygen free copper wire provides extraordinary signal transfer resulting in amazing sound
- 24K Gold-plated plug assures optimal connectivity
- Strain relief and fabric reinforced cable for strength
- Headphones fold flat for storage

In-line multifunction control with microphone*

The one button control performs many useful commands and is supported by most mobile phone and portable media players. Some devices may require you to click two times or to hold the button down for a few seconds to activate some commands. Not all features will work for every device. Refer to the user's manual for your device to see which features are supported. Please note that not all manuals list the one-touch button features, even though they are supported.







Microfiber travel bag

Protects your headphones and doubles as a cleaner for your smartphone or media player

Frequency Response: 20Hz to 20,000Hz
 Cable Type: Fabric covered
 Cable Length: 4' 4" (1.32 M)
 Plug Type: 3.5 mm



Color options

<p>Black & Dark Chrome</p>  <p>BDH821BDGP</p>	<p>White & Dark Chrome</p>  <p>BDH821WH</p>	<p>Black, Blue & Dark Chrome</p>  <p>BDH821BKBL</p>	<p>Black, Graphite & Chrome</p>  <p>BDH821BKGP</p>
--	---	--	---

*Works with most Apple®, Android™, and BlackBerry® devices. Compatible with iPod®, iPhone® and iPad®. Also compatible with other electronic devices using a 3.5mm headphone port.



What's included

- One pair of over-the-ear headphones
- Soft protective storage case
- Black, red, and blue color covers

Features

- In-line multifunction controller with microphone*
- High definition sound & precision bass
- Tangle-free, fabric covered removable cable
- Soft, comfortable memory foam ear cushions
- Comfortable EVA foam padded headband
- Lightweight design using low mass metal construction
- 99% Oxygen free copper wire provides extraordinary signal transfer resulting in amazing sound
- 24K Gold-plated plug assures optimal connectivity
- Strain relief and fabric reinforced cable for strength

In-line multifunction control with microphone*

The one button control performs many useful commands and is supported by most mobile phone and portable media players. Some devices may require you to click two times or to hold the button down for a few seconds to activate some commands. Not all features will work for every device. Refer to the user's manual for your device to see which features are supported. Please note that not all manuals list the one-touch button features, even though they are supported.



Soft protective case included

Protects and stores your headphones. Plush inner lining and pockets for additional storage.



Frequency Response: 20Hz to 20,000Hz
 Cable Type: Fabric covered
 Cable Length: 4' 4" (1.32 M)
 Plug Type: 3.5 mm

Included color options



Interchangeable black, red, and blue color covers included

*Works with most Apple®, Android™, and BlackBerry® devices. Compatible with iPod®, iPhone® and iPad®. Also compatible with other electronic devices using a 3.5mm headphone port.

TV Wall Mounts





Low profile:
Mounts TV only .7" from wall

Features

- Heavy duty steel construction
- Durable baked-on piano black powder-coated finish
- Expandable to 200 x 100 mm or 200 x 200mm with *included* adapter plates
- Simply lift the TV on or off the wall mount; security screw locks the TV into place
- Complete TV mounting hardware included
- Low profile

Specifications

Measurements:	5" x 5" (127 x 127 mm)
For TV Sizes:	12" - 37"
Weight Capacity:	40 lbs (18 kg)
Mounting Configurations:	75 x 75 mm - 200 x 200 mm
Mount Type:	Fixed Low Profile



Adapter plates Included
for larger mounting
configurations





**Adapter plates included
for larger mounting
configurations**

Features

- Tilts from -3° to $+10^{\circ}$
- Heavy duty steel construction
- Durable baked-on piano black powder-coated finish
- Expandable to 200 x 100 mm or 200 x 200mm with *included* adapter plates
- Simply lift the TV on or off the wall mount; security screw locks the TV into place
- Complete TV mounting hardware included
- Low profile

Specifications

Measurements:	5" x 5.3" (127 x 134 mm)
For TV Sizes:	12" - 37"
Weight Capacity:	40 lbs (18 kg)
Mounting Configurations:	75 x 75 mm - 200 x 200 mm
Mount Type:	Tilting





Arm extends to 16.1" from wall



Cable management



Adapter plates Included for larger mounting configurations

Features

- Tilts from -3° to +15°
- Easy tilt lever mechanism
- Pans right to left
- Heavy duty steel construction
- Arm extends from 2.1" to 16.1" from wall
- Durable baked-on piano black powder-coated finish
- Expandable to 200 x 100 mm or 200 x 200mm with *included* adapter plates
- Attractive wall plate covers
- Cable Management
- Complete TV mounting hardware included



Specifications

Measurements:	5" W x 11" H x 16.2" L (extended)
For TV Sizes:	12" - 37"
Weight Capacity:	40 lbs (18 kg)
Mounting Configurations:	75 x 75 mm - 200 x 200 mm
Mount Type:	Tilt/Pan/Articulating





Arms swing away from wall



Padlock not included

Padlock feature

Features

- Low profile mounts TV less than 0.75" from wall
- Arms swing away from wall for easy TV & cable access
- Easy TV height and level adjustment feature
- Hanging arm design makes installation simple
- Heavy duty steel construction
- Durable baked-on piano black powder-coated finish
- Optional padlock feature for extra security
- Complete TV mounting hardware included



Leveling feature

Specifications

Measurements:	23.6" x 15.3" (599 x 389 mm)
For TV Sizes:	26" - 42"
Weight Capacity:	125 lbs (56.7 kg)
Mounting Configurations:	Up to 500 x 300 mm
Mount Type:	Fixed Ultra Low Profile





Features

- Mount extends from 3.25" up to 11.25" from wall
- Tilts from -3° to +15° forward
- Solid heavy-gauge steel construction
- Durable baked-on piano black powder-coated finish
- Mounts to just one stud
- Cable management
- Decorative wall plate covers
- Complete TV mounting hardware included



Cable management

Specifications

Measurements:	17.25" W x 17.37" H x 10.8" L (extended)
For TV Sizes:	32" - 55"
Weight Capacity:	60 lbs (27 kg)
Mounting Configurations:	Up to 400 x 400 mm
Mount Type:	Tilt/Pan/Articulating





Tilt lever



Cable management

Features

- Mount extends from 2.2" up to 13.25" from wall
- Tilts from -3° to +15° forward with easy to reach tilt lever
- Heavy duty steel and aluminum construction
- Durable baked-on piano black powder-coated finish
- Mounts to just one stud
- Cable management
- Decorative wall plate and end caps
- Complete TV mounting hardware included

Specifications

Measurements: 28.4" x 17.5" (720 x 445 mm)

For TV Sizes: 32" - 55"

Weight Capacity: 80 lbs (36 kg)

Mounting Configurations: Up to 600 x 400 mm

Mount Type: Tilt/Pan/Articulating

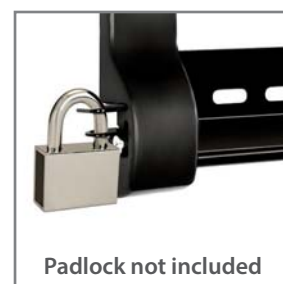

Tilt mechanism

Padlock not included

Padlock feature

Features

- Tilts from -5° to $+15^{\circ}$
- Unique locking system
- Heavy duty steel construction
- Durable baked-on piano black powder-coated finish
- Decorative end caps
- Optional padlock feature for extra security
- Complete TV mounting hardware included

Specifications

Measurements:	34.25" x 18.6" (870 x 472 mm)
For TV Sizes:	37" - 90"
Weight Capacity:	200 lbs (91 kg)
Mounting Configurations:	Up to 700 x 440 mm
Mount Type:	Tilting



Tilt lever

Easy TV leveling feature

Features

- Tilts from -5° to $+15^{\circ}$
- Can mount into 1 or 2 studs; can be offset mounted to 1 stud*
- Heavy duty steel construction
- Easy TV height and leveling adjustment
- Adjustable TV height and leveling feature
- Unique pull string arm locking/release mechanism
- Durable baked-on piano black powder-coated finish
- Decorative end caps
- Complete TV mounting hardware included

Specifications

Measurements:	21.1" x 18.5" (536 x 470 mm)
For TV Sizes:	37" - 70"
Weight Capacity:	130 lbs (59 kg) / 80 lbs (36.3 kg)
Mounting Configurations:	100 x 100 mm to 400 x 400 mm
Mount Type:	Tilting
Patent pending	

* Never exceed the maximum load capacity of: 130 lbs. (59 kg) when installed into 2 studs or masonry installations; or 80 lbs. (36.3 kg) when installed into 1 stud.





Arms swing away from wall



Padlock not included

Padlock feature



Easy TV leveling feature

Features

- Low profile - mounts TV less than 0.75" from wall
- Arms swing away from wall for easy TV & cable access
- Easy TV height and level adjustment feature
- Hanging arm design makes installation simple
- Heavy duty steel construction
- Durable baked-on piano black powder-coated finish
- Optional padlock feature for extra security
- Complete TV mounting hardware included

Specifications

Measurements:	31.2" x 19.25" (792 x 489 mm)
For TV Sizes:	37" - 70"
Weight Capacity:	150 lbs (68 kg)
Mounting Configurations:	Up to 700 x 400 mm
Mount Type:	Fixed Low Profile



7835B

Tilt/Pan/Articulating TV Wall Mount
For TV Sizes 37" - 70"



Cable management

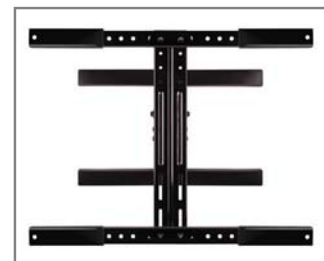

Adapter plates included for larger mounting configurations

Features

- Mount extends from 2.75" up to 12.6" from wall
- Tilts from -3° to +15°
- Heavy duty steel construction
- Durable baked-on piano black powder-coated finish
- Cable management
- Decorative wall plate covers
- Complete TV mounting hardware included

Specifications

Measurements: 28.375" x 17.5" (720.7 x 444.5 mm)

For TV Sizes: 37" - 70"

Weight Capacity: 80 lbs (36 kg)

Mounting Configurations: Up to 600 x 400 mm

Mount Type: Tilt/Pan/Articulating





Simple tilt system



Cable management

Features

- Mount extends from 2.3" up to 21.3" from wall
- Tilts from -3° to +15°
- Simply pull to tilt, then release to lock in place
- Heavy duty steel construction
- Durable baked-on piano black powder-coated finish
- Cable management
- Decorative wall plate and end caps
- Complete TV mounting hardware included

Specifications

Measurements:	27.5" x 17.8" (699 x 452 mm)
For TV Sizes:	32" - 70"
Weight Capacity:	130 lbs (59 kg)
Mounting Configurations:	Up to 600 x 400 mm
Mount Type:	Tilt/Pan/Articulating



Mounts most Soundbars above or below TVs 37" - 90"

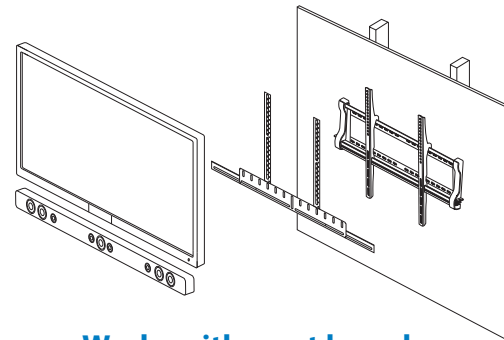

Works with most brands
of wall mount



Mount Soundbar below TV



Mount Soundbar above TV



Mount Soundbar on post mount



Features

- Ultra low profile - only 3/8" (9.5 mm) thick
- Universal - All parts included to accommodate most brands of Soundbars & TVs
- Soundbar can be mounted above or below most flat panel TVs, or with most TV mounting systems
- Fits standard TV mounting configurations from 100 X 100 mm to 600 X 400 mm
- Heavy duty steel construction
- Fully adjustable mounting

Specifications

Weight Capacity: 30 lbs (13.6 kg)

TV Mounting Configurations: 100 x 100 mm -
600 x 400 mm

Soundbar mounting configurations:

Fits soundbars with mounting hole configurations up to 41" wide (with included extensions) and up to 30 lbs in weight.

Surge Protectors



Features

- 3 Outlets
- 3.4 Amp Shared USB charging ports (for phone and tablet)
- USB auto device detection
- 540 Joules
- RF & EMI advanced noise filtration
- Protected light
- Security outlet screw
- Fireproof MOV



Specifications

Electrical Rating:	15A, 120V, 60Hz, 1800 Watts
Surge Lines Protected:	3-Line (L-N, L-G, N-G)
UL Clamping Voltage:	L-N 400V, L-G 400V, N-G 400V
Surge Energy Joule Rating:	540 Joules
Maximum Spike Current:	72,000 Amps (3 Line Total)
Response Time:	< 1 Nanosecond
Maximum Spike Voltage:	6 kV
EMI/RFI Noise Filter:	Frequency:150KHz - 100MHz
Attenuation:	Up to 40dB
Breakdown Volts:	< 75V
Insertion Loss:	< 0.1 dB



Features

- 2 Outlets
- 3.4 Amp Shared USB charging ports (for phone and tablet)
- USB auto device detection
- 306 Joules
- RF & EMI advanced noise filtration
- Protected indicator
- Convenient for travel
- Fireproof MOV
- Universal Travel Adapter



Specifications

Electrical Rating:	110/220V, 50/60Hz
Surge Lines Protected:	3-Line (L-N, L-G, N-G)
UL Clamping Voltage:	L-N 400V, L-G 400V, N-G 400V
Surge Energy Joule Rating:	306 Joules
Maximum Spike Current:	72,000 Amps (3 Line Total)
Response Time:	< 1 Nanosecond
Maximum Spike Voltage:	6 kV
EMI/RFI Noise Filter:	Frequency:150KHz - 100MHZ
Attenuation:	Up to 40dB
Breakdown Volts:	< 75V
Insertion Loss:	< 0.1 dB





Features

- 7 outlets
- 1080 Joules
- Slim compact design
- Power switch with circuit breaker
- Protected light
- Coax Protection
- Fireproof MOV

- 6 Ft. Power Cord
- Angled, Flat Plug for Tight Spaces



Specifications

Electrical Rating:	15A, 120V, 60Hz, 1800 Watts
Surge Lines Protected:	3-Line (L-N, L-G, N-G)
UL Clamping Voltage:	L-N 400V, L-G 500V, N-G 400V
Surge Energy Joule Rating:	1080 Joules
Maximum Spike Current:	72,000 Amps (3 Line Total)
Response Time:	< 1 Nanosecond
Maximum Spike Voltage:	6 kV
EMI/RFI Noise Filter:	Frequency:150KHz - 100MHz
Attenuation:	Up to 40dB
DSS/Coax Cable Line Protection:	Surge Arrestor: Gas Tube
Breakdown Volts:	< 75V
Insertion Loss:	< 0.1 dB



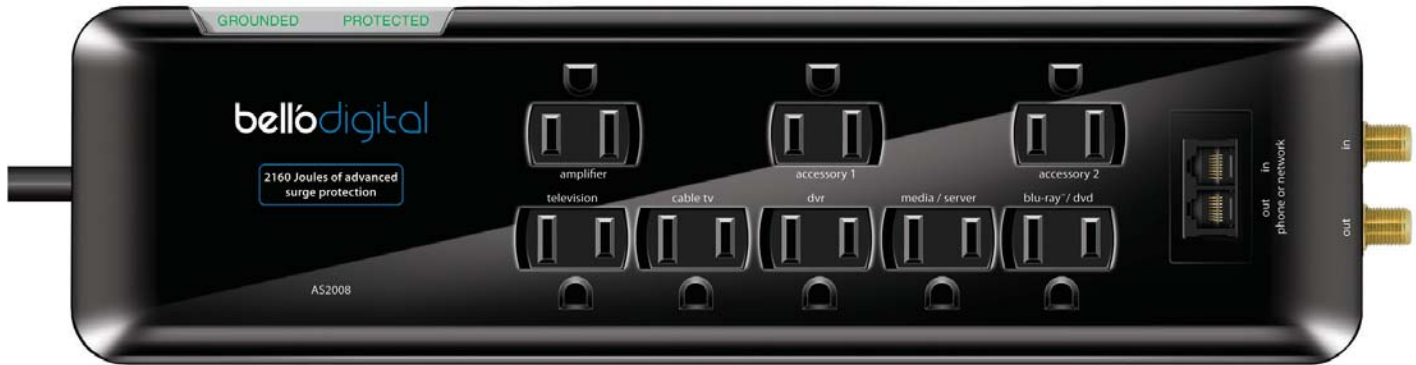

Features

- 8 outlets
- 2160 Joules
- Slim compact design
- Power switch with circuit breaker
- Grounded light
- Protected light
- Phone/Network Protection
- Coax Protection
- Fireproof MOV
- 6 Ft. Power Cord
- Angled, Flat Plug for Tight Spaces
- 24K Gold-Plated Plug Connectors



Specifications

Electrical Rating:	15A, 120V, 60Hz, 1800 Watts
Surge Lines Protected:	3-Line (L-N, L-G, N-G)
UL Clamping Voltage:	L-N 400V, L-G 400V, N-G 500V
Surge Energy Joule Rating:	2160 Joules
Maximum Spike Current:	144,000 Amps (3 Line Total)
Response Time:	< 1 Nanosecond
Maximum Spike Voltage:	6 kV
EMI/RFI Noise Filter:	Frequency:150KHz - 100MHz
Attenuation:	Up to 40dB
DSS/Coax Cable Line Protection:	Surge Arrestor: Gas Tube
Breakdown Volts:	< 75V
Insertion Loss:	< 0.1 dB



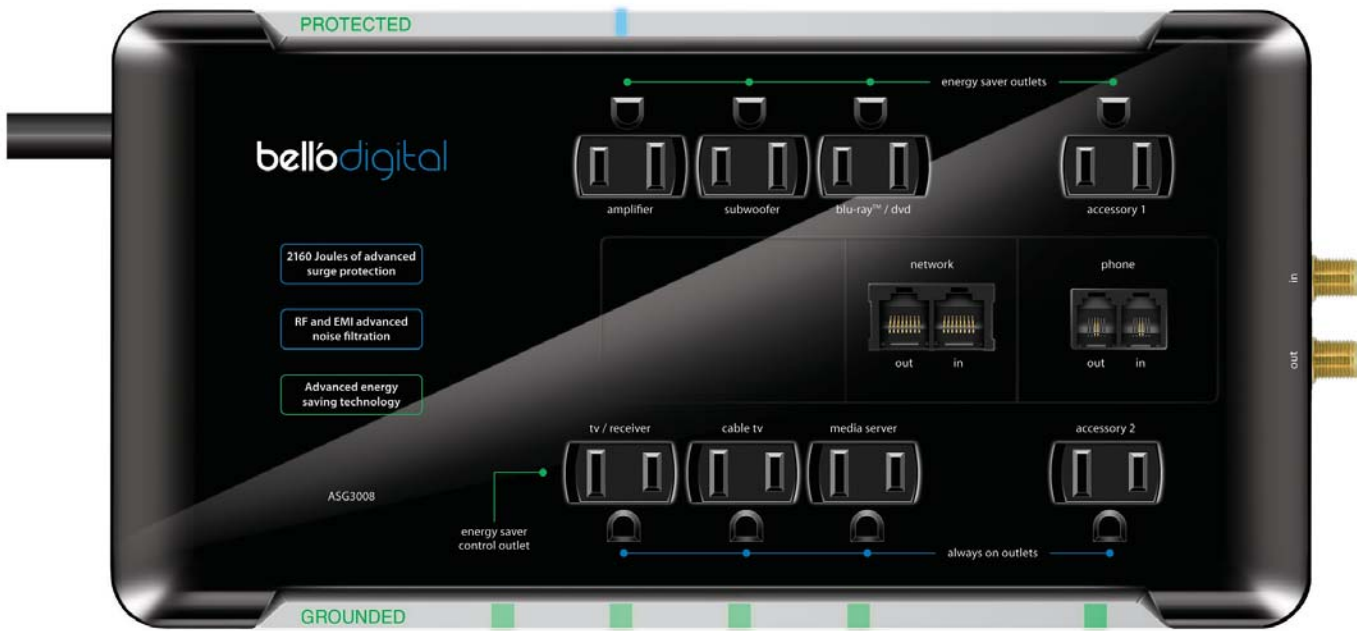

Features

- 8 outlets
- 2160 Joules
- Slim compact design
- Energy Saver Function
- Energy Saving/ Always On Switch
- Protected Light
- Grounded Light
- Phone Protection
- Network Protection
- Coax Protection
- Fireproof MOV
- 8 Ft. Power Cord
- Angled, Flat Plug for Tight Spaces
- 24K Gold-Plated Plug Connectors



Specifications

Electrical Rating:	15A, 120V, 60Hz, 1800 Watts
Surge Lines Protected:	3-Line (L-N, L-G, N-G)
UL Clamping Voltage:	L-N 330V, L-G 400V, N-G 400V
Surge Energy Joule Rating:	2160 Joules
Maximum Spike Current:	144,000 Amps (3 Line Total)
Response Time:	< 1 Nanosecond
Maximum Spike Voltage:	6 kV
EMI/RFI Noise Filter:	Frequency:150KHz - 100MHz
Attenuation:	Up to 48dB
DSS/Coax Cable Line Protection:	Surge Arrestor: Gas Tube
Breakdown Volts:	< 75V
Insertion Loss:	< 0.1 dB



Audio/Video Cables





1080p/4K

Highest Definition Video

Maximum Hz™

Supports All TV Enhanced Refresh Rates

Flexible Cable

Premium Ultra Thin and Flexible Cable for Today's Thinnest HDTVs



Actual Size

Features

- Premium Ultra Thin and Flexible Cable
- 10.2 Gbps High Speed Data Rate
- 1080p/4K Highest Definition Video
- 99.99% Oxygen Free Copper
- Maximum Hz Refresh Rate
- HDMI Ethernet Channel
- Audio Return Channel
- Content Type
- Life Jacket® protective cable covering is UL CMG listed for in-wall installation.

Available lengths

1 m (3.3 Ft)	HD3101
2 m (6.6 Ft)	HD3102
4 m (13.1 Ft)	HD3104
7.6 m (25 Ft)	HD3125





1080p/4K
Highest Definition Video

Maximum Hz™
Supports All TV
Enhanced Refresh Rates

Flexible Cable
Premium Ultra Thin
and Flexible Cable for
Today's Thinnest HDTVs



Features

- Premium Flexible Cable
- 10.2 Gbps High Speed Data Rate
- 1080p/4K Highest Definition Video
- Ethernet
- 3D Ready
- 99.99% Oxygen Free Copper
- Maximum Hz Refresh Rate
- HDMI Ethernet Channel
- Audio Return Channel
- Content Type
- Life Jacket® protective cable covering is UL CMG listed for in-wall installation

Cable length

15.2 m (50 Ft) HD3150





Includes

- 2M (6.6 Ft.) Thin High Speed HDMI Cable with Ethernet
- Mini/Micro to HDMI Adapter
- Bonus Travel Carry Case

HDMI cable features

- 10.2 Gbps TruSpeed™ Tested Speed Rating
- 3D Ready
- Ethernet
- LifeJacket®
- 99.99% Oxygen Free Copper
- 1080p / 4K / Maximum Hz™



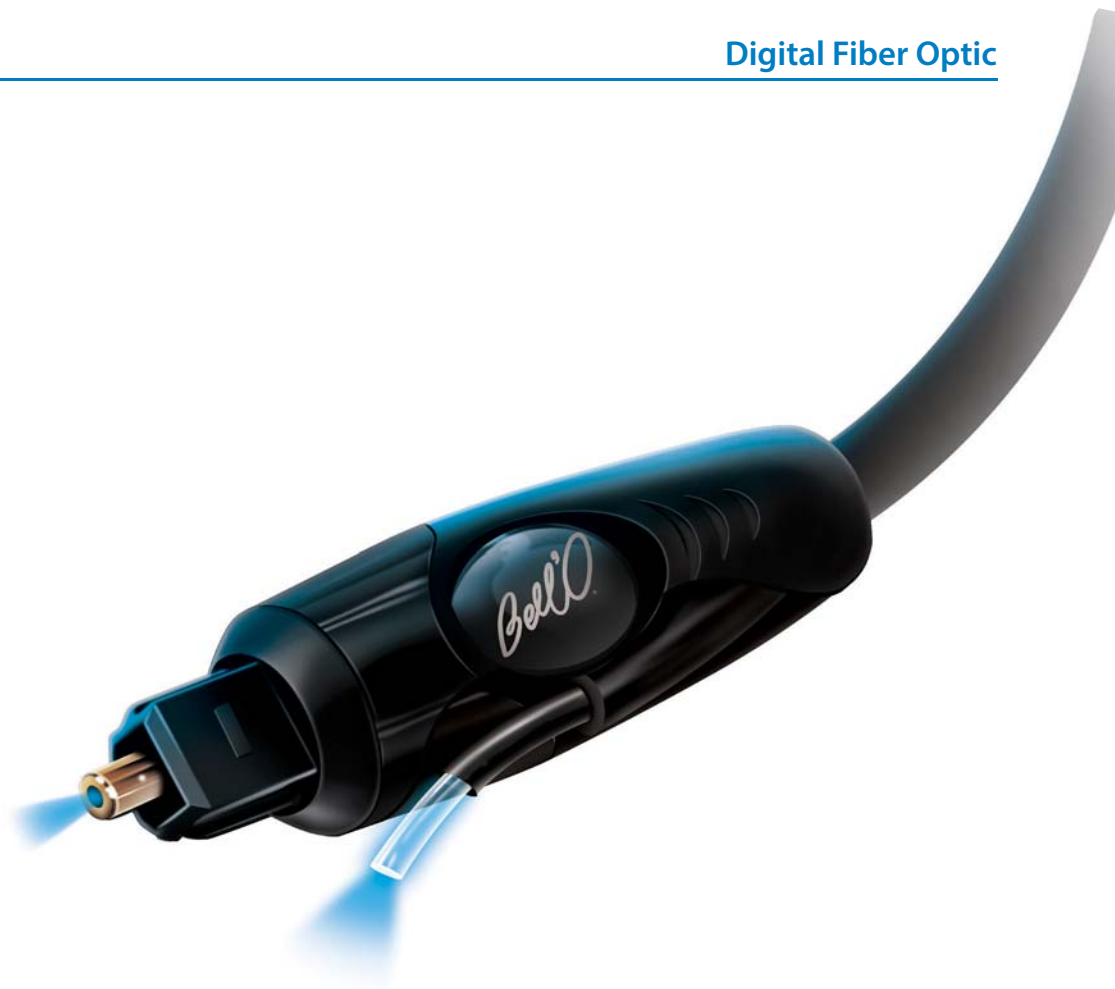

Features

- LifeJacket® OFNG Listed for In-Wall Installation
- Spring Loaded Connector Ends
- Precision Finished Fiber Optic End
- Multi-Layer Insulation
- 99.99% Oxygen Free Copper

Available lengths

1 m (3.3 Ft)	DF3201
2 m (6.6 Ft)	DF3202
4 m (13.1Ft)	DF3204



Accessories



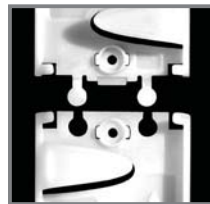

Includes

- Two 3" x 18" Cable Management Channels
- Adjustable Cable Management Channel
- 90° Corner Channel
- 3 Decorative End Caps
- 3M™ Double-Sided Tape
- Mounting Screws
- Dry Wall and Masonry Anchors

Features

- No cutting required - unique sliding panel cover design adjusts in length from 18" to 59"
- Holds 6 to 9 cables
- Wall mounted track restrains cables quickly and easily
- Attractive, painted linen white surface
- Looks great on most walls or can be easily painted with household paints to match
- Decorative end caps
- Locks the covers to the wall track
- Precise interlocking components
- Connectable components make installation simple and ensures a straight channel
- Mounting screws and wall anchors included for installation into wood, drywall and masonry surfaces
- 3M™ brand double-sided mounting tape included when drilling is not desired



Includes

- 10 Travel Size Wipes - 6" x 5.25"

Screen cleaner features

Great for use with:

- | | |
|---|--|
| <ul style="list-style-type: none"> • Smartphones • Tablets • Laptop & computer screens • Eyeglasses | <ul style="list-style-type: none"> • LCD & Plasma televisions • Camera lenses • CDs & DVDs • Blu-ray discs™ • MP3 players |
|---|--|



Wipe packets are compact and convenient for travel
Wipe size: 6" x 5.25"

Blu-ray disc and the Blu-ray disc logo are trademarks of the Blu-ray Disc Association.



Includes

- 100 Travel Size Wipes - 6" x 5.25"

Screen cleaner features

Great for use with:

- Smartphones
- Tablets
- Laptop & computer screens
- Eyeglasses
- LCD & Plasma televisions
- Camera lenses
- CDs & DVDs
- Blu-ray discs™
- MP3 players



Wipe packets are compact and convenient for travel
Wipe size: 6" x 5.25"

Blu-ray disc and the Blu-ray disc logo are trademarks of the Blu-ray Disc Association.

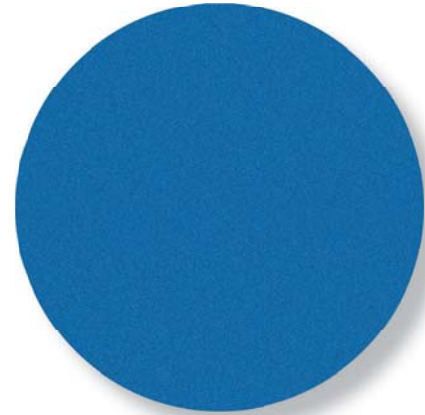

9" MicroFilament™
cleaning cloth

Includes

- 9 oz. (270 ml) cleaner
- 9" (228 mm) diameter MicroFilament™ cleaning cloth

Screen Cleaner Features

- Vented cap assures dry, clean storage of the included MicroFilament™ cleaning cloth
- Specially developed to gently clear harmful finger oils and dust from your screen surface
- Great for cleaning LCD & Plasma TV screens, personal devices, DVDs & CDs, smart phones, tablets, computer monitors, eyeglasses, laptop screens, cameras, MP3 players, and more
- Large MicroFilament™ cloth is optical quality to clean and protect delicate surfaces safely
- Alcohol/Ammonia free
- Residue free
- Anti-static
- Safe for daily use