

banks

with Installation Instructions
Owner's Manual

**Banks Monster[®]
Exhaust Rear
Quads System**

**2007-2008 Chevy/GMC 1500 Silverado, 6.0L V-8
Gas, Vortex Max**

THIS MANUAL IS FOR USE WITH MONSTER EXHAUST SYSTEMS 48347

banks

General Installation Practices

- 1.** Before starting work, familiarize yourself with the installation procedure by reading all of the instructions.
- 2.** The exploded view (**Figure 1**) provides only general guidance. Refer to each step and section diagram in this manual for proper instruction.
- 3.** Throughout this manual, the left side of the vehicle refers to the driver's side, and the right side to the passenger's side.
- 4.** Disconnect the negative (ground) cable from the battery (or batteries, if there are two) before beginning work.
- 5.** Route and tie wires and hoses a minimum of 6" away from exhaust heat, moving parts and sharp edges. Clearance of 8" or more is recommended where possible.
- 6.** When raising the vehicle, support it on properly weight-rated safety stands, ramps or a commercial hoist. Follow the manufacturer's safety precautions. Take care to balance the vehicle to prevent it from slipping or falling. When using ramps, be sure the front wheels are centered squarely on the topsides. When raising the front of the vehicle, put the transmission in park, set the parking brake, and block the rear wheels. When raising the back of the vehicle, be sure the vehicle is on level ground and the front wheels are blocked securely. **Caution! Do not use floor jacks to support the vehicle while working under it. Do not raise the vehicle onto concrete blocks, masonry or any other item not intended specifically for this use.**
- 7.** During installation, keep the work area clean. Do not allow anything to be dropped into intake, exhaust, or lubrication system components while performing the installation, as foreign objects will cause immediate engine damage upon start-up.

Tools Required:

- 1/2" and 3/8" drive ratchets with standard and metric sockets and 1/2" and 3/8" drive extension
- Standard and metric combination or open-end wrenches
- Standard screwdriver
- Clean shop towels or rags
- Pry-bar

Highly recommended tools and supplies:

- Foot-pound torque wrench
- Penetrating oil or light lubricant spray

General Assembly

Figure 1

Item #	Description	P/N	QTY
1	Intermediate Pipe	53639	1
2	Monster Muffler	54005	1
3	Y-Pipe	53648	1
4	Tailpipe Left	53646	1
5	Tailpipe Right	53647	1
6	Dual Tip Assembly	53645	2
7	Front Muffler Hanger Clamp	53640	1
8	Rear Muffler Hanger Clamp	53642	1
9	3" Exhaust Saddle Clamp	52465	2
10	3" Exhaust Band Clamp	52466	2
11	Rubber Insulator	53732	1
12	Frame Hanger Bracket	53605	1
13	Bolt, 7/16"	91629	1
14	Washer, SAE Flat, 7/16"	91602	1
15	Hanger Plate, 2x2"	53291	1
16	Washer, SAE Flat, 1/2"	91902	1
17	Nut, Crimp Lock	91619	1
18	Factory 10mm Nuts	Stock	2
19	Banks Urocal	96009	2

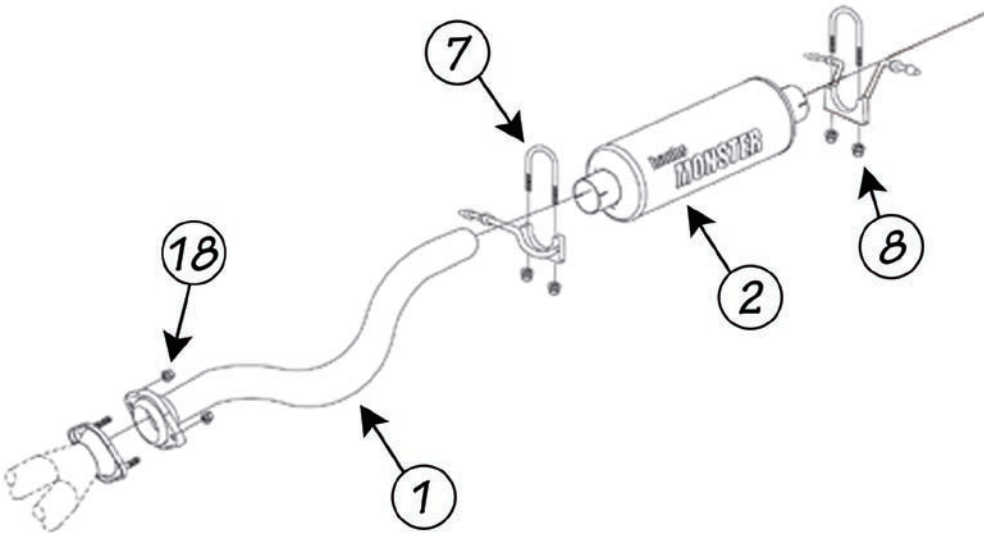

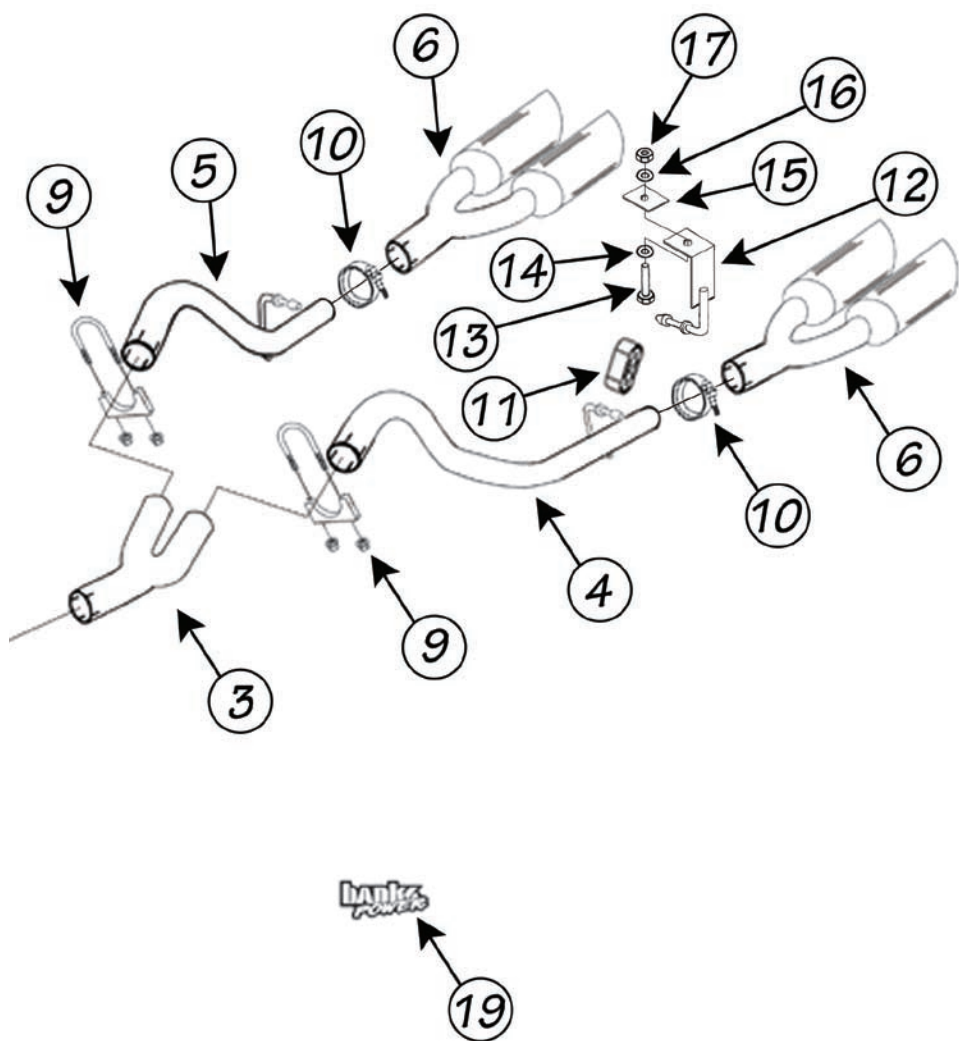

Monster Exhaust System Installation

1. Disconnect the negative (ground) cable from the battery (if there is more than one battery, disconnect both negative cables). Secure the cable so it cannot accidentally come in contact with the post.

2. Raise the vehicle and support it securely with properly weight-rated safety stands, ramps or a commercial hoist. Take care to balance the vehicle to prevent it from slipping or falling. When using ramps, be sure the wheels are centered squarely on the topsides. Place the transmission in park (automatic), set the parking brake and securely block the wheels that are on the ground.

CAUTION: DO NOT WORK UNDER ANY VEHICLE SUPPORTED ONLY BY A JACK. SEVERE INJURY MAY RESULT.

3. Loosen and remove the two (2) nuts on the 2-bolt flange, retain for reassembly. Remove the tailpipe hanger pin from the rubber hanger. Remove the rear muffler hanger pin from the rubber hanger. Remove the front muffler hanger pins from the rubber hangers.

NOTE: Spray lubricant may assist in hanger pin removal. Rubber hangers can also be removed from the vehicle to assist in tailpipe / muffler removal.

4. Remove the tailpipe, muffler and intermediate pipe assembly from the vehicle

5. Install the 2-bolt flange on the inlet of the Banks intermediate pipe to the factory flange. Loosely install the two (2) factory 10mm nuts onto the factory 2-bolt flange studs.

6. Install the front hanger clamp onto the intermediate pipe outlet. Insert the hanger pin into the vehicles rubber hanger (see **Figure 2**).

7. Install the Monster Muffler inlet (Note the inlet labeling of the muffler) onto the intermediate pipe outlet. Orient the Monster logo such that is visible from the passenger side and parallel with the frame rail. Align the clamp onto the muffler inlet (see **Figure 2**).

NOTE: Once the pipe / muffler has been completely engaged in the slip joint, mark the pipe with a scribe or tape for reference when tightening the clamps later in the installation. Mark each slip joint in this fashion.

8. Install the rear muffler hanger clamp onto the Monster Muffler outlet. Insert the hanger pin into the vehicles rubber hanger (see **Figure 2**).

NOTE: All clamps should be positioned at the beginning of the slots (on the 1/2 circle punch).

9. Install the Banks Y-Pipe into the muffler outlet such that the outlets are pointing up. Install the 3" Exhaust clamps onto each Y-Pipe outlet.

10. Install the Banks hanger brackets onto the rear of the frame rail. Be sure the hanger pin is align parallel to the frame rail and torque the hardware to 48ft-lb. See **Figure 3**.

11. Install the supplied rubber insulators onto the Banks hanger bracket.

12. Install the driver-side tailpipe onto the left Y-pipe outlet. Install the driver-side tailpipe hanger into the Banks rubber insulator. See **Figure 4**.

13. Install the passenger-side tailpipe onto the right Y-pipe outlet. Install the passenger-side tailpipe hanger into the vehicle rubber insulator. See **Figure 4**.

Figure 2

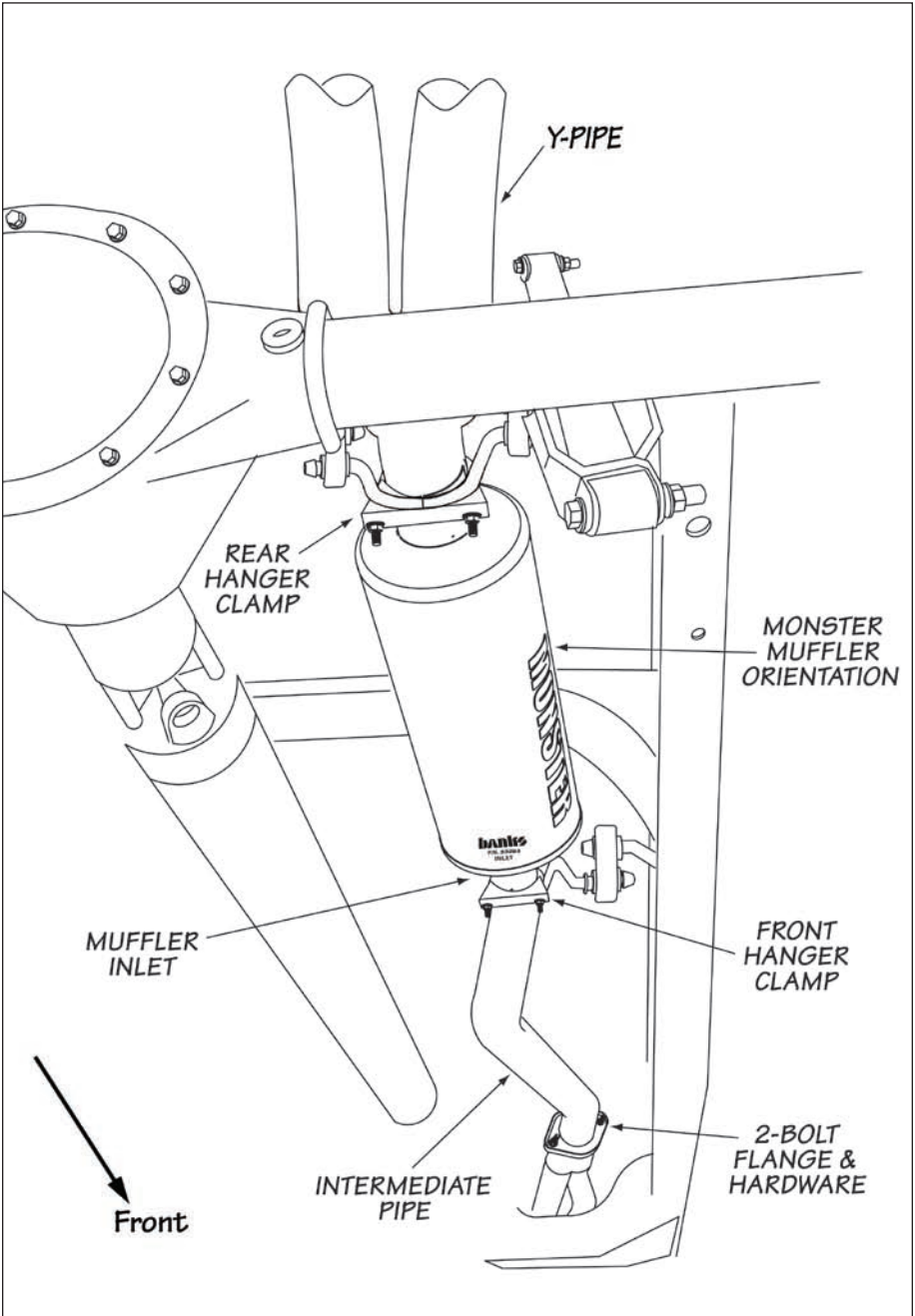

Figure 3

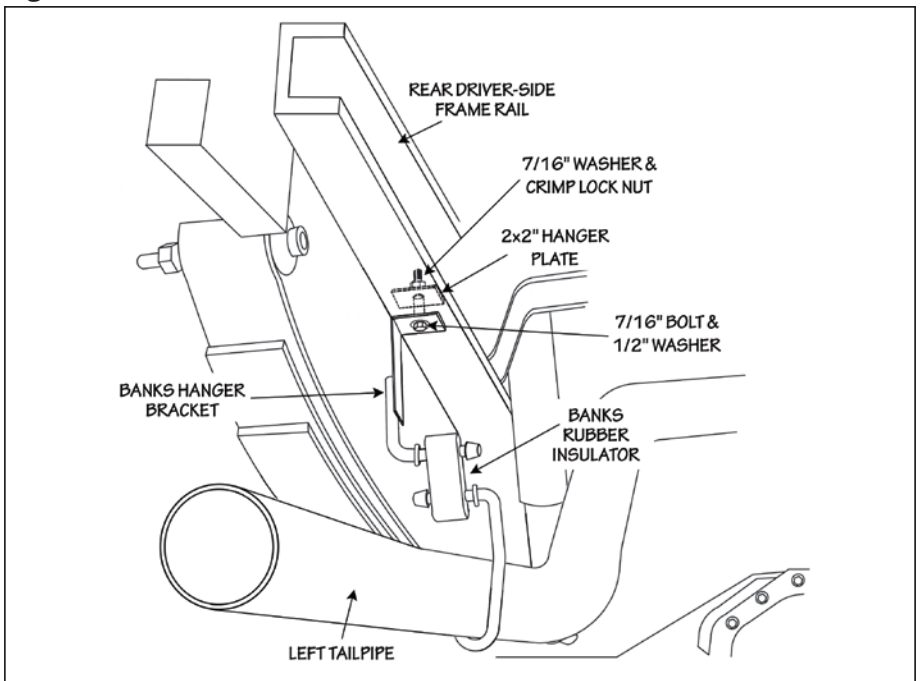

Figure 4

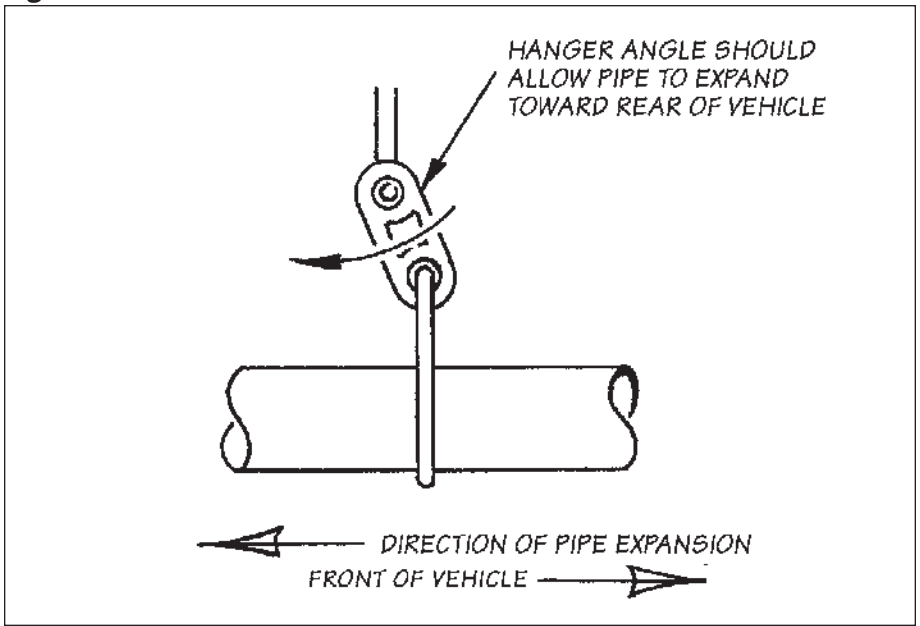
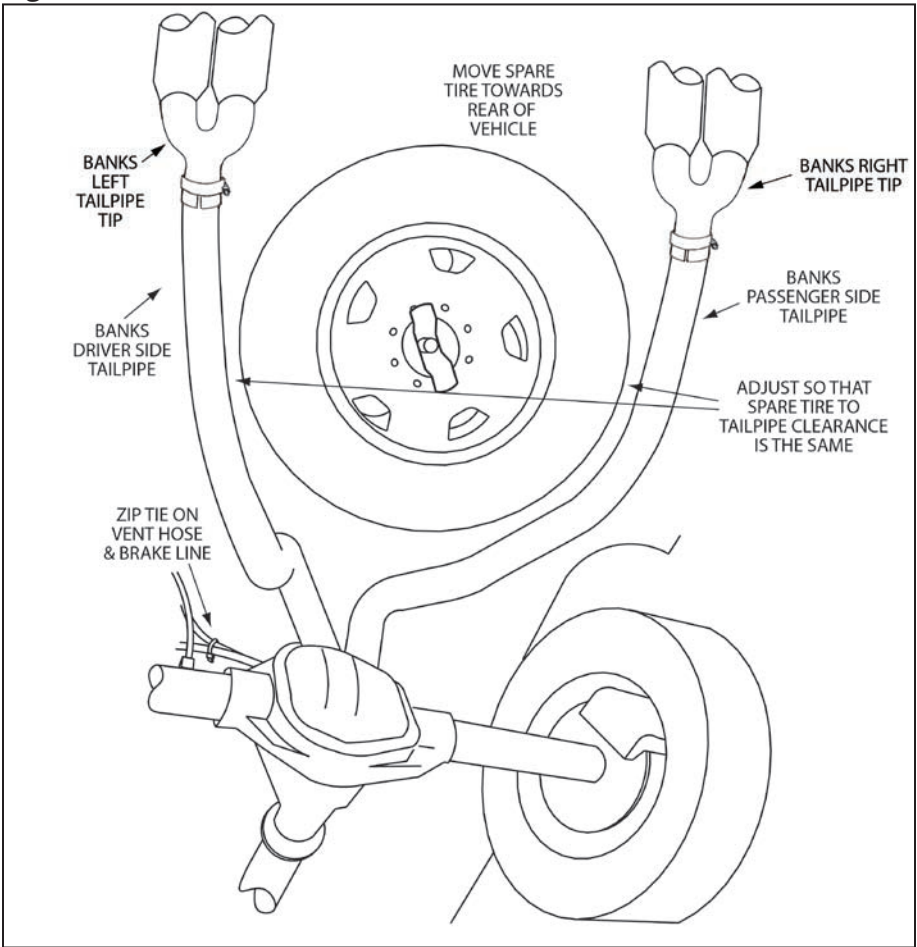

Figure 5



14. Move the spare-tire to the rear of the vehicle and center between the dual tailpipes. Tighten the spare tire with the manufacture tire tool so that it is retained into place (see **Figure 5**).

15. Install the 3" Band clamp onto the outlet of the left tailpipe and install the Dual tip assembly onto the left tailpipe. Keep the wrapping on until installation is complete. The tip and the clamp should be rotated so the clamp nut is pointing down. Repeat this process for the right side tailpipe tip installation.

16. Be sure that the two (2) tailpipes are completely engaged into the Y-pipe. Adjust your tailpipes so that the tips are symmetrical and 1" below the rear bumper. The hanger pins should be parallel with the frame-mounted pin and the rear rubber hangers are all slightly positioned forward.

NOTE: Recommended distance between exhaust tip and body is half (1/2") inch to one (1") inch.

Figure 5



17. Beginning with the clamps closest to the catalytic converters, and working your way back, align the saddle clamps to the radius of the corresponding pipe slots. Torque the nuts on each of the exhaust clamps and 2-bolt flange to 35 ft-lb.

18. Remove the protective covering from the tailpipe tips.

Caution: the protective covering may ignite and burn if not removed prior to running the engine.

19. Your system includes two (2) Banks Power logos designed to complement the Chevy/GMC emblems on the vehicle's front doors. See **Figure 5** for recommended logo placement.

20. Re-connect the negative battery cable. Start the engine and listen for exhaust leaks. Tighten the exhaust clamps as necessary. Whenever possible, tack weld slip connections to prevent disengagement is recommended. The Banks Monster Exhaust installation is now complete.