

Part Number: TTU-301



Kit Contents

Item #	Quantity Req'd.	Description
1	2	Fog Lamps w/bezel
2	1	Switch Assembly
3	1	Fog light operation guide
4	1	Hardware bag

Hardware Bag Contents

Item #	Quantity Req'd.	Description
1	1	Wire harness
2	1	Switch harness
3	2	Relays
4	25	Wire ties
5	3	2 Black & 1 Yellow T-taps

Conflicts

-

General Applicability





Models:

Recommended Tools

Safety Tools	
Safety Glasses	
Electrical Tape	
Installation Tools	
10mm Wrench	
Phillips Screw Driver	
Pliers	
Side Cutters	
Torque wrench	
Special Chemicals	
3M Silicon Sealant	

Mandatory

Legend

	STOP: Damage to the vehicle may occur. Do not proceed until process has been complied with.
	OPERATOR SAFETY: Use caution to avoid risk of injury
	CRITICAL PROCESS: Proceed with caution to ensure a quality installation. These points will be audited on a completed vehicle installation
	TOOLS & EQUIPMENT: This calls out the specific tools and equipment required for this process
	REVISION MARK: This mark highlights a change in installation with respect to previous issue.

Care must be taken when installing this accessory to ensure damage does not occur to the vehicle. The installation of this accessory should follow approved guidelines to ensure quality installation.

Preparation



Disconnect the negative terminal of the battery

Installation

1. Secure the relay to the wire loom next to the Battery with wire ties. Secure top and bottom with wire ties (see picture 1). Note: It is suggested to loosen the battery from the base and move it to allow extra working room.



Picture 1

2. Attach the ring terminal with 2 black wires to the 10mm ground bolt next to the battery (see picture 2)



Picture 2

3. Locate the large vehicle harness grommet on the left side. Cut the auxiliary wiring access nipple off the grommet and push the two red and gray/white wires through firewall. Seal with 3M Silicone sealant (see picture 3)



Picture 3

4. Run the fog light wire harness on the driver side of the car. Use wire ties as needed

Vehicle Disassembly

- 5. Remove the left front door scuff plate: detach the 6 claws and 3 clips (picture 6)

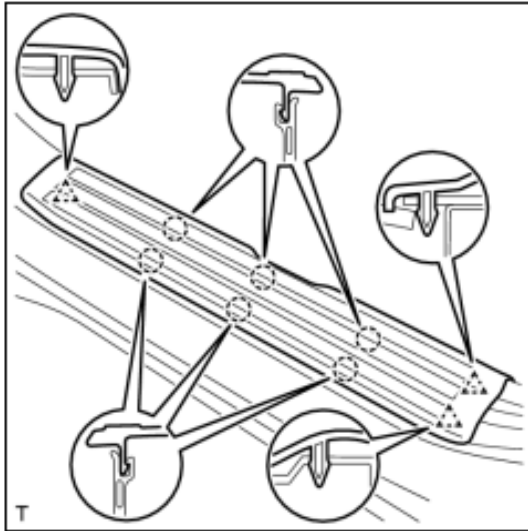

Picture 6

- 6. Remove the cowl side trim: remove the clip, then detach the 2 clips (picture 7)

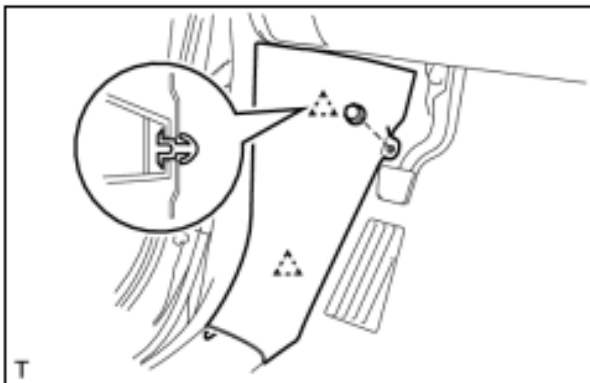

Picture 7

- 7. Remove the screws on the lower part of the instrument panel. Remove lower instrument panel (picture 8)

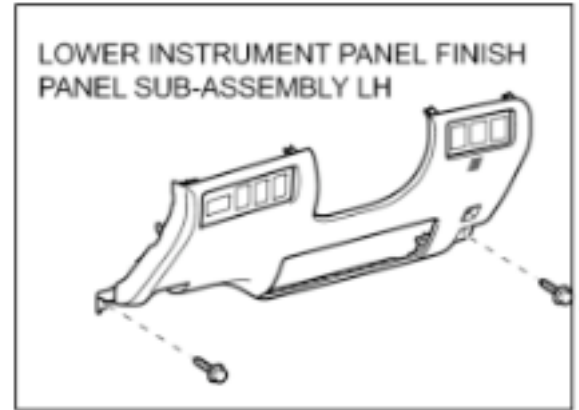

Picture 8

- 8. Mount switch into switch knockout on left side of dash (picture 9)



Picture 9

- 9. From inside the cabin, locate the wires that were pushed through in step 4. It will be the grommet above the gas pedal (picture 10)

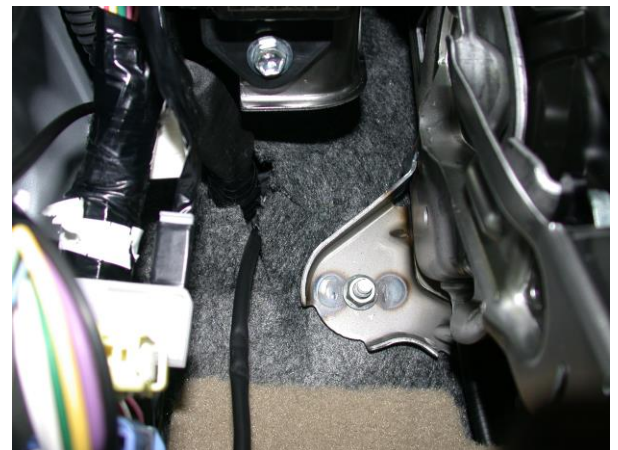

Picture 10

- 10. Install switch harness (picture 11)



Picture 11

- 11. Locate the junction box behind the lower instrument panel (picture 12)



Picture 12

- 12. T-tap green/black wire from fog light harness to connector DB pin 16, red wire. Connector DB is in the driver's side junction box, located on the left side of the steering column (pic. 13, 13A & 13B)
- 13. T-Tap orange/black wire from fog light harness to connector DB pin 18, blue wire, right side third pin up from bottom (picture 13, 13A, 13B, 13C and 13D)

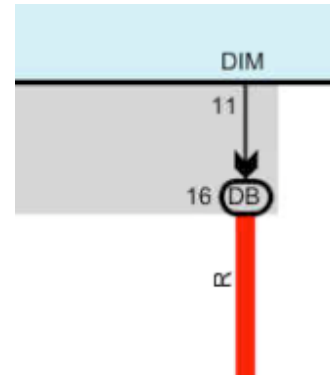

Picture 13: Connector DB, pin 16

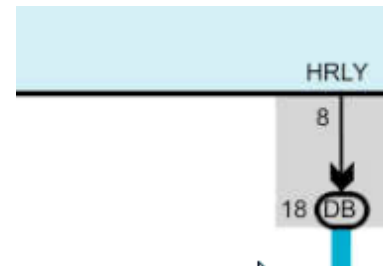

Picture 13A: Connector DB, pin 18

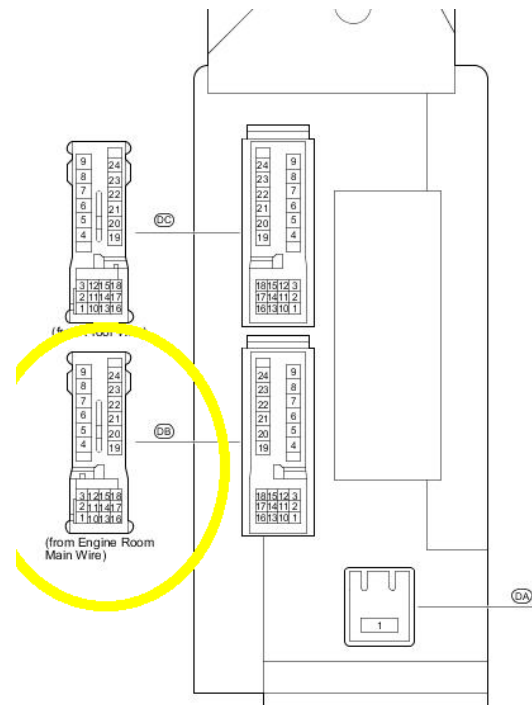

Picture 13B

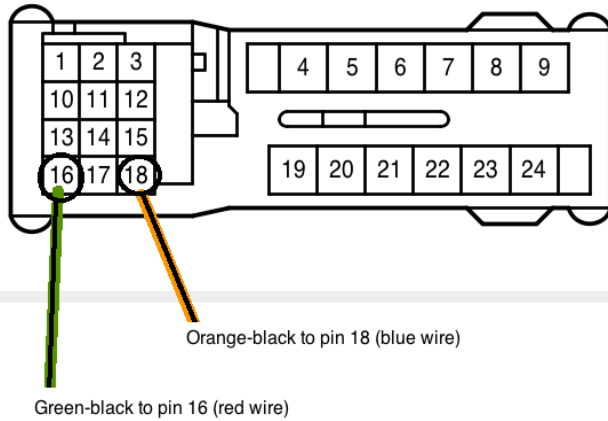

Picture 13C

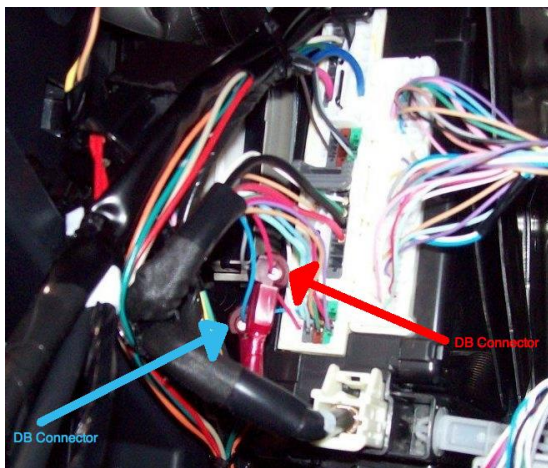

Picture 13D

- Secure the supplied yellow T-Tap to the black wire of connector DB, pin 7. Connector DB is located at the wiper motor circuit (picture 14, 14A and 14B)

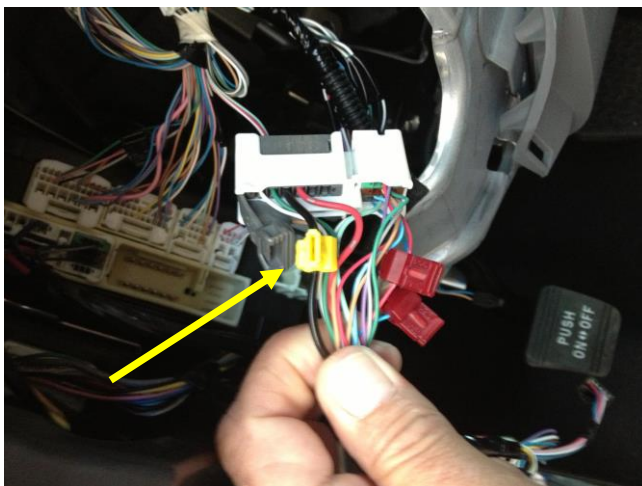

Picture 14: showing yellow t-tap

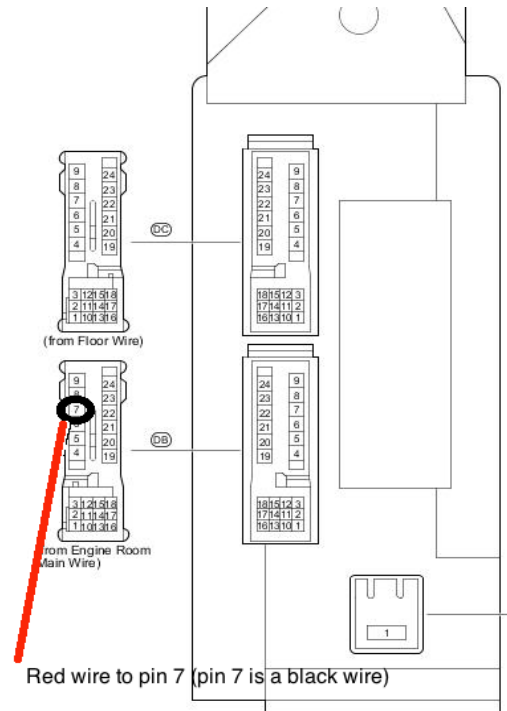

Picture 14A

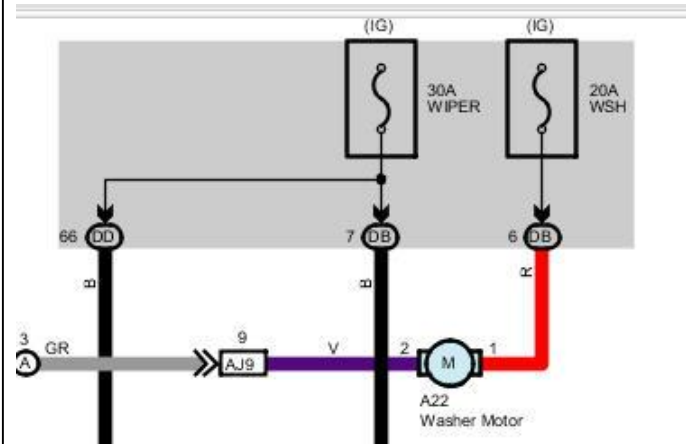

Picture 14B

- Connect the red and gray/white wires with bullet connectors from outside harness to inside harness red and gray/white wires. Connect the 14 gage red wire from fog light harness to the supplied fuse. Connect the other end of the fuse to the yellow t-tap installed in step 14 (pictures 14 and 15)

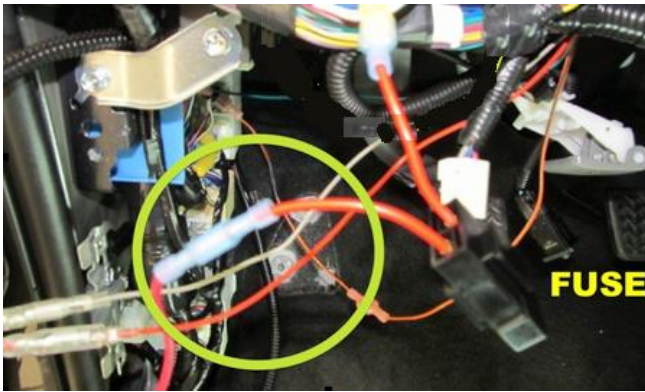

Picture 15

- 16. Secure with wire ties.
- 17. Reinstall dash panels
- 18. Route the fog light wire under car.
- 19. Remove splash shields
- 20. Remove both front bumper hole covers. Detach wire harness clamps and release the 3 claws and remove (picture 16)

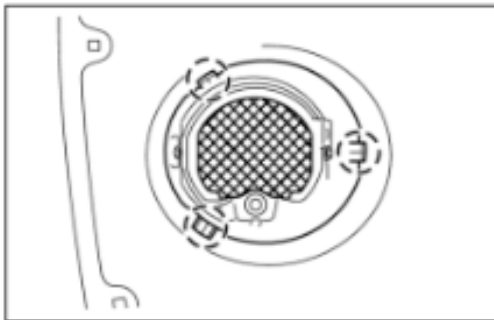

Picture 16

- 21. Re-secure detached wire harness and plug in left side fog light into harness plug and secure with wire ties. Snap fog light bezel into bumper hole (picture 17)



Picture 17

- 22. Run right side of wire harness through bumper sub frame to right fog lamp opening (picture 18)

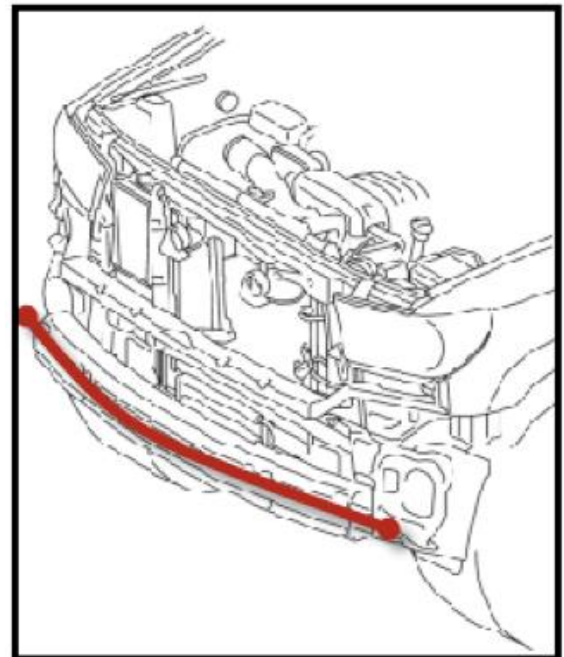

Picture 18: Fish passenger side harness through bumper sub assy

- 23. Plug harness into right fog light. Install wire ties to secure to vehicle. Snap fog light bezel into bumper hole
- 24. Reattach the lower splash shields

25. Re-connect battery. Make sure battery is properly secured to its base. Torque terminals to 36 in-lb

Check System for Operation

1. Reconnect battery negative terminal
2. Turn on headlamp low beams, then press fog light switch to "ON" position. Fog lights should be working. Fog lights will only work when the low beam headlamps are "ON". Fog lights will NOT work when the high beam headlamps are "ON"

Fog Light Aiming

Traditional fog lights are usually mounted in the front bumper about 10-24 inches from the ground. There are two important issues to address when installing fog lights: the first is to minimize the amount of return glare into the drivers eyes, and the other is to minimize the glare into oncoming eyes. Both of these issues must be accomplished while putting as much light as possible on the road.

These fog weather light aiming instructions are suggestions taken from common practice and the S.A.E. standard J583. Some modifications to these instructions may be necessary to minimize glare.

Visual aim is made with the top of the beam 4 inches below the lamp center at 25 feet with the lamp facing straight forward (see picture 18)

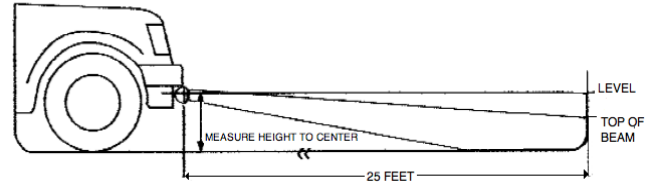

Picture 18

Check

Accessory Functions Checks

- Fog Lights function
- All Panels snapped into place.....
- Fog Lights.....
- Battery Terminal.....

Vehicle Function checks

- Check functions all switch functions

Look For:

.....

Loose panels and switches

Visually confirm lights are straight forward

Re-torque negative battery terminal to 36 in-lb

Place fog light operation guide inside glove

box