



# **FITTING INSTRUCTIONS**

**Part Number: 3468010 / 3468020 F/KIT: 6172336 BOLT PACK 6172337**

**Product Description: H3 HUMMER COMBINATION BAR**

**Suited to vehicle/s: GM H3 HUMMER APRIL 2007 ONWARDS**

## **WARNING**

### **REGARDING VEHICLES EQUIPPED WITH SRS AIRBAG;**

**When installed in accordance with these instructions, the front protection bar does not affect operation of the SRS airbag.**

### **ALSO, NOTE THE FOLLOWING:**

- ◆ **This product must be installed exactly as per these instructions using only the hardware supplied.**
  - ◆ **In the event of damage to any bull bar component, contact your nearest authorised ARB stockist. Repairs or modifications to the impact absorption system must not be attempted.**
  - ◆ **Do not use this product for any vehicle make or model, other than those specified by ARB.**
  - ◆ **Do not remove labels from this bull bar.**
  - ◆ **This product or its fixing must not be modified in any way.**
  - ◆ **The installation of this product may require the use of specialized tools and/or techniques**
  - ◆ **It is recommended that this product is only installed by trained personnel**
  - ◆ **These instructions are correct as at the publication date. ARB Corporation Ltd. cannot be held responsible for the impact of any changes subsequently made by the vehicle manufacturer**
  - ◆ **During installation, it is the duty of the installer to check correct operation/clearances of all components**
  - ◆ **Work safely at all times**
  - ◆ **Unless otherwise instructed, tighten fasteners to specified torque**
-

# GENERAL CARE AND MAINTENANCE

By choosing an ARB Bar, you have bought a product that is one of the most sought after 4WD products in the world. Your bar is a properly engineered, reliable, quality accessory that represents excellent value. To keep your bar in original condition it is important to care and maintain it following these recommendations.

- Prior to exposure to the weather your bar should be treated to a Canuba based polish on all exposed surfaces. It is recommended that this is performed on a six monthly basis or following exposure to salt, mud, sand or other contaminants.
- As part of any Pre Trip Preparation, or on an annual basis, it is recommended that a thorough visual inspection of the bar is carried out, making sure that all bolts and other components are torqued to the correct specification. Also check that all wiring sheaths, connectors, and fittings are free of damage. Replace any components as necessary.
- Please contact local Authorised ARB Stockist if you would like to have this service carried out on your behalf.

## HAVE AVAILABLE THESE SAFETY ITEMS WHEN FITTING PRODUCT:

**BASIC TOOL KIT**

**JIG SAW OR KEY HOLE SAW**

**Small drill, 8mm,10mm and (13mm drill bit if fitting winch )**

Protective eyewear



Hearing protection



**NOTE:** *'WARNING' notes in the fitting procedure relate to OHS situations, where to avoid a potentially hazardous situation it is suggested that protective safety gear be worn or a safe work procedure be employed. If these notes and warnings are not heeded, injury may result.*

## FASTENER TORQUE SETTINGS:

SIZE	Torque Nm	Torque lbft
M6	9Nm	4lbft
M8	22Nm	16lbft
M10	44Nm	32lbft
M12	77Nm	57lbft

USE	PART No	QTY	DESCRIPTION
MOUNTING SYSTEM	3757629LHS	1	BRACKET MOUNT ASSEMBLY LHS
	3757629RHS	1	BRACKET MOUNT ASSEMBLY RHS
	4584297	2	WASHER STEPPED
	6151255	2	BOLT M12 X 40 X 1.75
	4581288	2	WASHER FLAT ½" HD GOLD
	4581050	2	WASHER SPRING ½"
	6151189	2	NUT M12 X 1.75
	4581049	2	WASHER FLAT ½"
BULL BAR TO MOUNTING SYSTEM	6151357	8	BOLT M10 x 30mm SEMS ASSY
	6151304	6	NUT CAGED M10
	6151321	2	NUT FLANGE M10 X 1.5
CONTROL BOX BRACKET	6151021	2	BOLT M8 x 20mm
	4581044	2	WASHER FLAT M8
	6151132	2	NUT FLANGE M8
	3751564	1	CONTROL BOX BRACKET
	3756499	1	CONTROL BOX BRACKET (9.5 XP WINCH)
NUMBER PLATE BRACKET	6151180	4	BOLT M6 x 20mm (BRACKET TO BAR)
	6151046	4	WASHER FLAT M6 x 13mm
	6151128	4	NUT FLANGE M6
	3751634	1	NUMBER PLATE BRACKET
INDICATORS TO BAR	3163015	1	COMBINATION LIGHT SURROUND KIT
	6821151L	1	TURN SIGNAL / CLEARANCE LIGHT LHS
	6821151R	1	TURN SIGNAL / CLEARANCE LIGHT RHS
	6821152	2	TURN SIGNAL / CLEARANCE LIGHT LOOM
	180701	6	SCOTCH LOK
PANEL WINCH COVER	6522696	1	PANEL WINCH COVER
	6151256	2	SCREW M6 X 16MM BUTTON HEAD S/S
	6151128	2	NUT FLANGE M6
	6191006	1	EXTRUSION WINCH COVER
WINCH FITMENT	BLB 600	1	BATTERY LEAD 600MM BLACK
	180302	8	CABLE TIES
	6151073	2	BOLT 3/8" X 1 ½"
	6151074	2	BOLT 3/8" X 1 ¾"
	4581040	4	WASHER FLAT M10
	EG50	2	GROMMET RUBBER
STONE SHIELD	4581032	2	WASHER PACKER STONESHIELD
TO REFIT RADIATOR AIR INTAKE	6151416	6	XMAS TREE CLIPS

**TO FIT OPTIONAL FOG LIGHTS TO BAR, USE KIT NO. 6821201 AND WIRING HARNESS PART NO. MD02**

**FACTORY FOG LIGHTS DO NOT FIT INTO THE BAR**

**ASSEMBLY SEQUENCE FOR BULL BAR INSTALLATION.  
PLEASE READ AND UNDERSTAND FITTING INSTRUCTIONS BEFORE  
ATTEMPTING TO FIT BAR TO VEHICLE**



**1. To fit a bar to vehicle, the bumper and grill panel has to be removed from vehicle.**



**2. To Remove grill from vehicle, undo nuts from under hood as per photo.**



**3. Next step is to undo bolts in grill opening as per photo using 1/4" drive extension plus 10mm socket.**





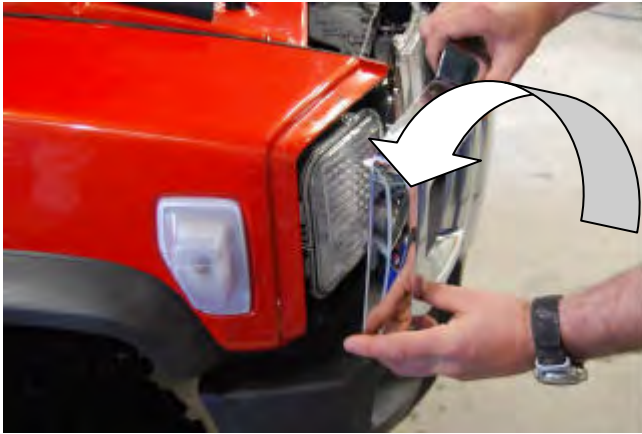

**4. Gently pull grill from around headlight assembly to release from push in retainer clips**



**5. Remove bolts that hold the skid pan to the bumper bar.**



**6. Undo bolts from inside bumper assembly.  
7. Remove recovery hook assemblies from bumper and unplug fog light loom from bumper before removing bumper from vehicle .**





OUTER BRACKETS

**8. Once the vehicle is up to this stage, remove skid pan from vehicle, then remove the outer brackets.**

**( Discard the outer brackets )**



**9. When the skid pan is removed from vehicle, the lower radiator tank protector pipe assembly has to be removed, as it has to be modified for the bull bar to be fitted to vehicle.**

**PHOTO IS OF REMOVED PIPE ASSEMBLY.**



**10. Using a cut off disc grinder, remove section where the arrow is pointing too in paragraph 9.**





**11. Once the sections are cutoff from both sides of the assembly, clean up the sharp edges with a file etc, and paint with black paint to protect against rust.**

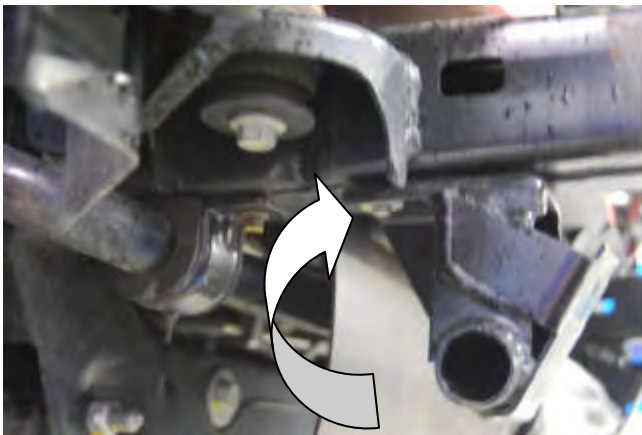

**12. Refit assemble back to vehicle using the rear bolts, finger tighten only.**

**PHOTO FROM RHS OF VEHICLE**



**13. If a winch is going to be fitted to the vehicle, the plastic radiator air dam assembly has to be removed from the front of the vehicle and modified for winch fitment, this requires the plastic push in Christmas tree clips to be removed. In most cases they have to be cut off using a wood chisel etc.**

**( New clips are provided in fitting kit for refittment. )**





**14. The white marked out section in photo, which runs along the tangent line of the lower profile, has to be cut out using a jig saw or a key hole saw.**  
**15. This is to give clearance for the winch.**

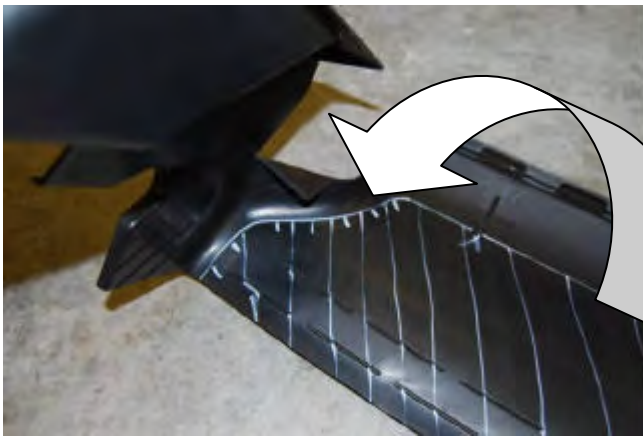

**16. The arrow shows a close up of the drawn line to be cut.**



**17. Photo shows the two separate parts.**



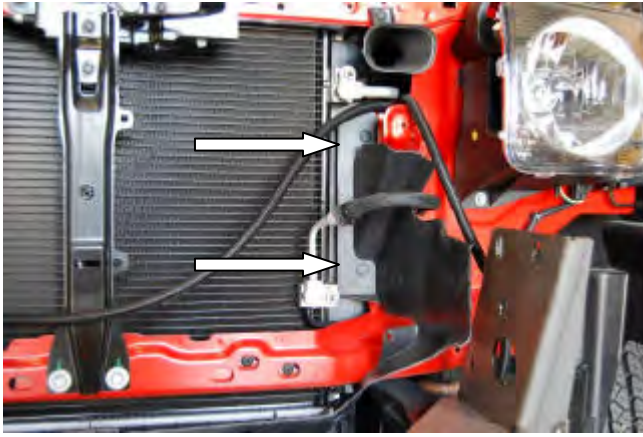

**18. When the part has been cut out to suit a winch, refit back to vehicle using new xmas tree clips supplied in bolt kit.**



**19. The next step is to fit bull bar mount assembly to vehicle chassis.**  
**20. These assemblies are left / right handed.**  
**21. Fit to vehicle using the two bolts that hold the tow hooks to the front of the chassis plates.**  
**22. Fit one side at a time temporarily using stone shield packers to fit brackets against chassis plates.**  
**( Finger tighten only ).**

**PHOTO IS OF RHS OF VEHICLE**



**23. Fit stepped washer inside of chassis rail and align hole in chassis rail and chassis bracket, then fit stepped washer into both holes.**



**24. Fit 12mm bolt and flat washer into stepped washer from outside of chassis bracket, into chassis rail of vehicle**



**25. To the inside of the vehicle chassis rail, secure using 12mm spring washer and 12mm nut, finger tighten only, then tighten the two front bolts firmly first, then tighten the rear 12mm bolt.**

**26. Carry out the same fitting procedure on the opposite side.**

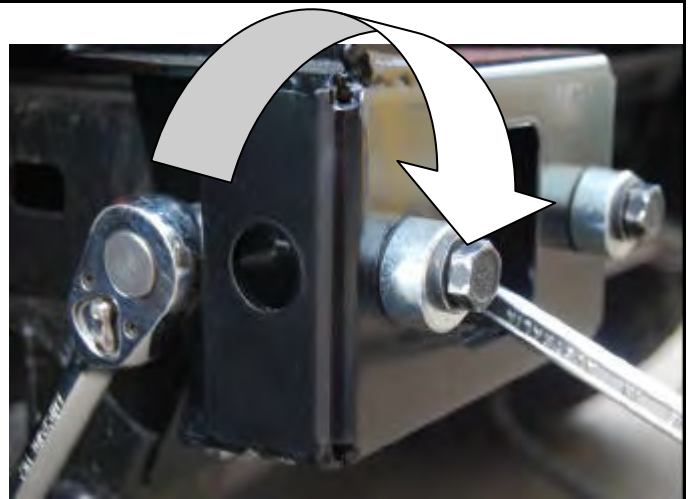



**27. When both brackets are fitted to vehicle, remove the front bolts.**

**ABOVE ARROW INDICATES FRONT BOLTS.**



**28. Using 8mm hole in underside of mounting bracket as a template, drill a 8mm hole (5/16") into lower radiator protector assembly flange.**

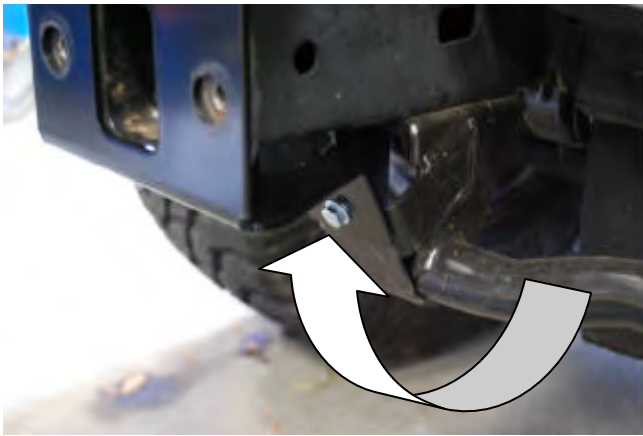

**29. Secure using 8mm hardware, then tighten previously fitted 8mm bolt in paragraph 12.**







- 30.** After fitting the brackets to the vehicle's chassis, the next step is to splice the bar' indicator / packer loom to the vehicle's wiring loom.
- 31.** To remove the headlight from vehicle, undo the four screws indicated by the arrows.



- 32.** Using a pair of pliers, squeeze the plastic clip and remove the metal bracket from vehicle.



- 33.** Gently pull the headlight assembly from vehicle and support whilst splicing to the bar loom.



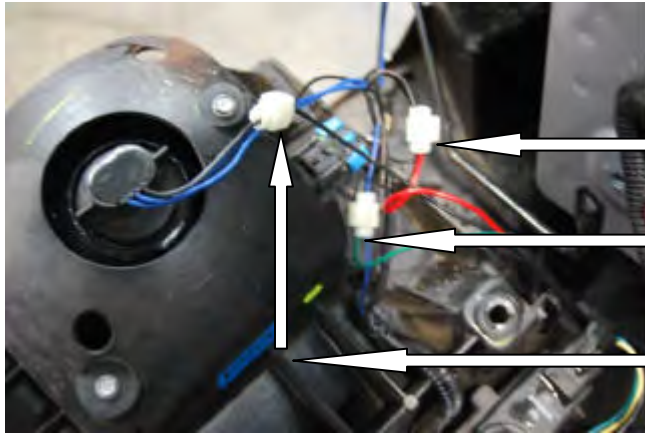

**34. By using scotch loks, connect**

**RED TO BROWN WIRE**

**GREEN TO BLUE WIRE  
FROM THE MAIN LOOM**

**BLACK TO BLACK WIRE**

**PHOTO IS RHS LIGHT ASSEMBLY**



**35. Carry out the same function to both sides of the vehicle, then refit light assemblies back to vehicle.**

**36. Arrows point to bar indicator / clearance light plugs.**

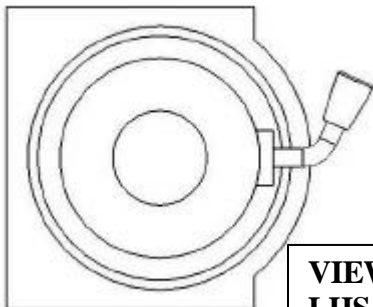

**ORIGINAL**

**VIEWED FROM  
LHS OF**

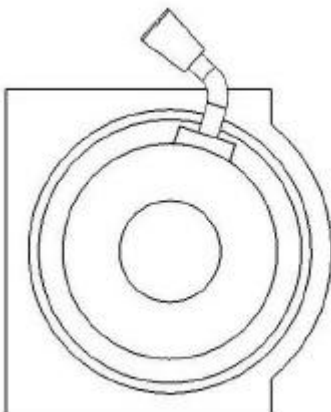

**ROTATED**

**TO FIT A WINCH BAR**

**37. To fit an 8/9/9.5/000lb winch, rotate gearbox 72° counterclockwise.**

**Stand winch upright and undo the capped head screws and by lifting the gearbox only a couple of millimeters, rotate the gearbox. Once in position, refit all screws and tighten firmly.**

**WARNING: Do not lift gearbox more than a couple of millimeters.**

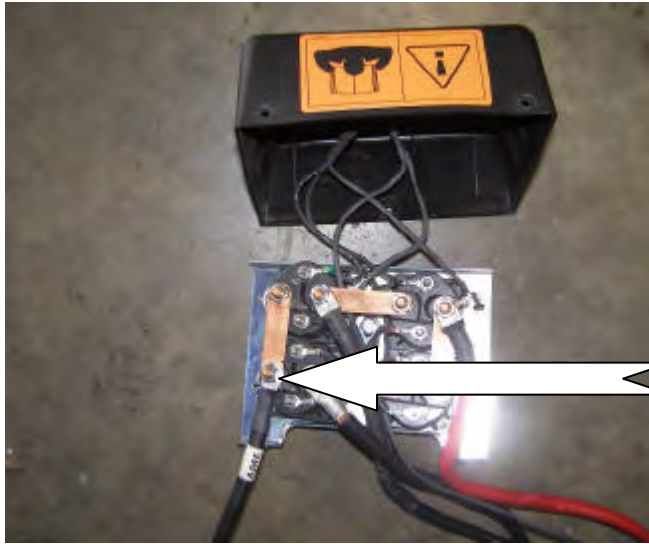

**38. To fit control box to bar, you must change the arrowed lead (yellow tagged) in photo with the longer lead that is supplied in fitting kit. When all is fitted, screw plastic cover back onto control box.**



**39. To fit winch into bar you must pack winch up on a bench to enable you to lower bar down on winch, then fit four 3/8" square nuts into winch lugs .**

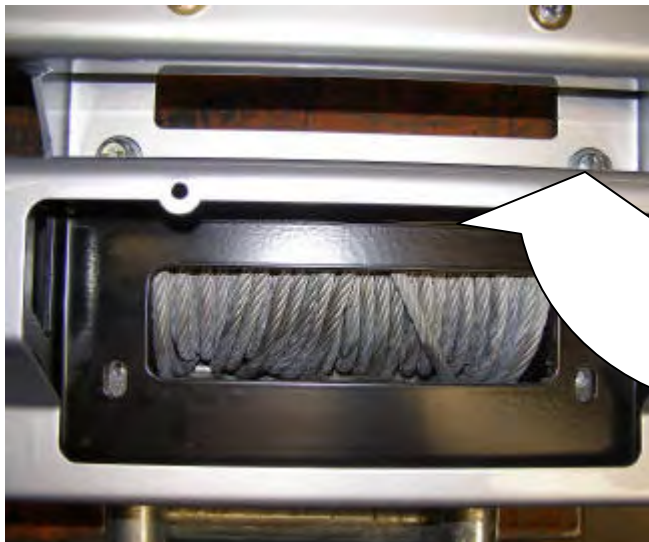

**40. Lower bar down over winch, line up top holes first and secure using 3/8" hardware (1 1/2" x 3/8" bolts) flat and spring washers. ( finger tighten only )**

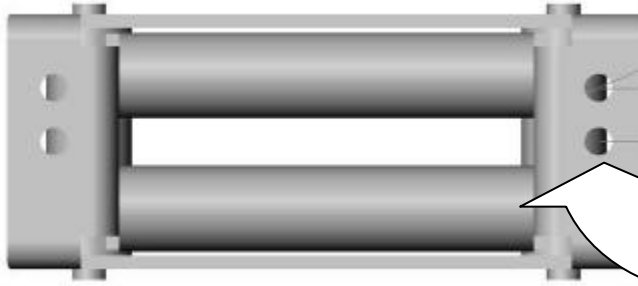

**41. Drill two new 13mm holes in the roller fairlead provided in the kit, as shown on the adjacent picture.**

Use new drill holes to bolt to bar.



**42. Place roller fairlead over lower holes and again secure using 3/8" hardware (1 3/4" x 3/8" bolts) flat and spring washers.**  
**43. Using circlip pliers, remove lower circlips and push shaft upwards to be able to move rollers sideways.**  
**44. Fit number plate bracket to bar using 6mm hardware.**



**45. Using screwdriver move vertical rollers sideways and tighten all bolts using socket and extension.**  
**46. Refit rollers and circlips.**







**47. If you are going to fit a 8000lb or a 9000lb winch use the low profile zinc plated control box bracket; but if you are going to fit a 9000lb XP winch, use the black powder coated angled control box bracket.**

**48. Fit control box bracket to bar using 8mm hardware.**

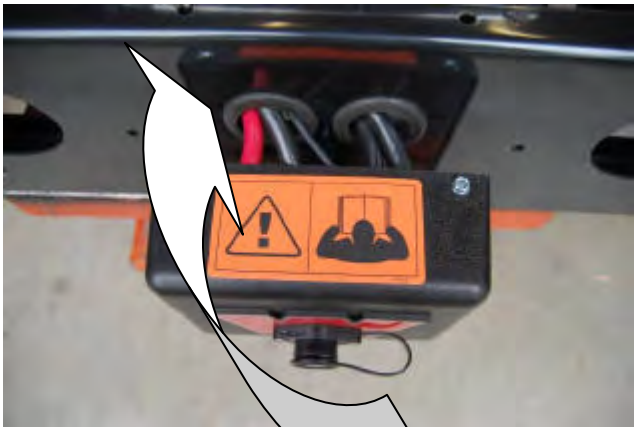

**49. Fit rubber grommets into round holes in top of bar, then fit control box to control box bracket and pass cables through rubber grommet.**

**ARROW INDICATES RUBBER GROMMETS.**

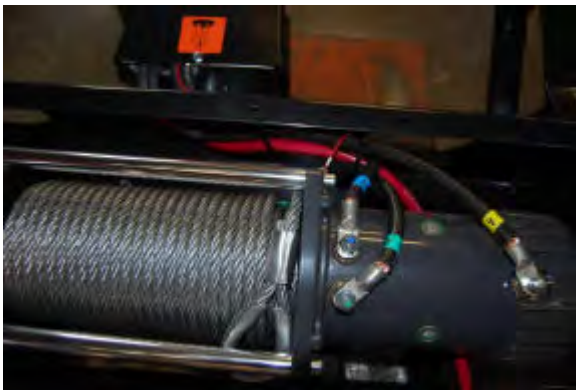

**50. Fit all 3 cables to their correct terminals and tighten. Refer to Warn installation instruction when wiring up winch. Fit plastic boots over terminals. Cable tie cables to bar as per photo to clear of all moving parts.**

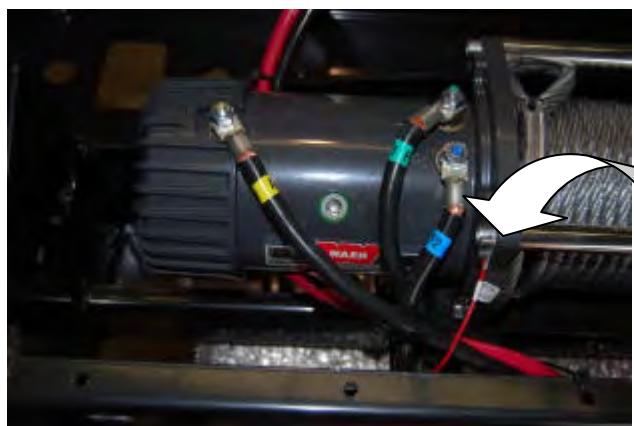

**51. Fit ground wire under winch tie rod. ( See Photo )**

**GROUND WIRE**



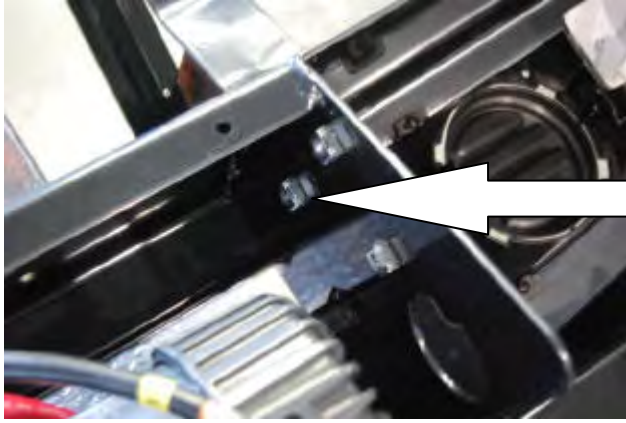

**52. Fit 10mm caged nuts into each side of bar. ( 3 per side )**

RHS SHOWN

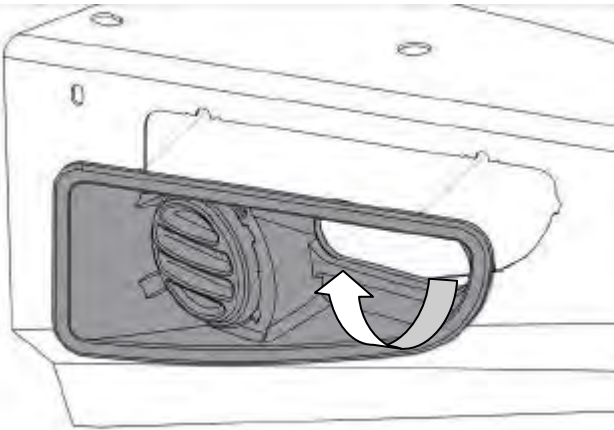

**Assemble and install combination light surrounds (p/n 3163015) as per instructions no. 3786421 supplied with surround kit. Note: Optional fog lamps can be installed at this point as per fitting instruction no. 3783315 supplied with fog lamp kit no. 6821201.**

**Wire the combination lamp to the vehicles indicator and clearance lamps.**

**Caution: Cable tie all cables together and keep all cables clear of sharp edges and moving parts.**

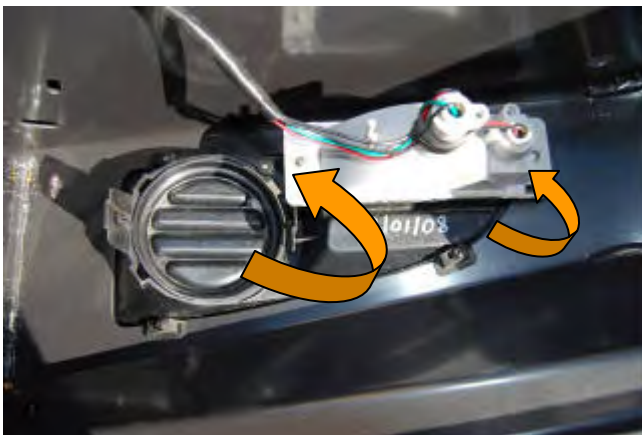

**54. Install the turn signal into the rear of light insert using 2 self tapping screws (6 x 25mm pan head) supplied with the light insert fitting kit.**

**NOTE :- The indicators should be installed with the drain holes at the bottom and are marked LH / RHS. ( Clearance lights outboard )**

ARROWS INDICATES POSITION OF SCREWS



**55. If optional fog lights are going to be fitted to bar , follow fitting instructions from fog light kit part no. 6821201 and wiring harness part.no.MD02**

**PHOTO IS FOG LIGHTS FITTED TO BAR**



**56. With the help of a friend, lift bar in between impact mounting bracket and align slots on mounting bracket to caged nuts on side of bar. Secure using M10 SEMS bolts. ( finger tighten only)**

**PHOTO IS LHS OF VEHICLE**



**57. When the 10mm bolts are fitted as above, refit the tow hook mount, finger tighten only.**



**58. Adjust bar so it sits level on vehicle and there is a 30mm gap on outside of bar.**

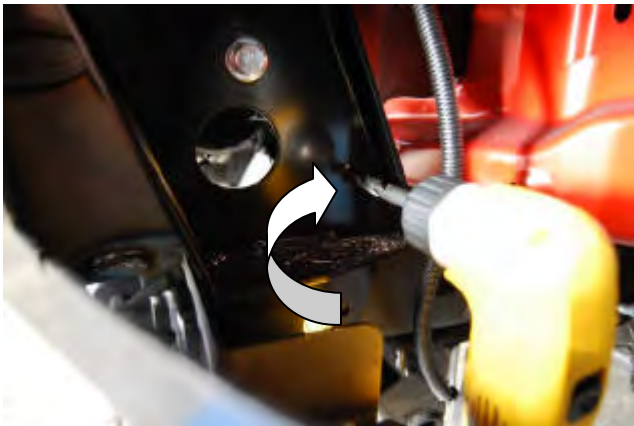

**59. Once bar is tighten to the correct adjustment, using a small drill or a right angle drill, drill a 10mm hole using the hole in mounting bracket as a template through the upright of the bar.**  
**60. Secure using 10mm hardware and tighten to torque specifications.**

**LIGHTING ASSEMBLY HAS BEEN REMOVED FOR CLARITY**



**BOLT ASSEMBLY TO USE**



**61. When the bar is secured to the vehicle, tighten the tow hook mount and refit tow hook and tighten just enough so it does not rattle.**



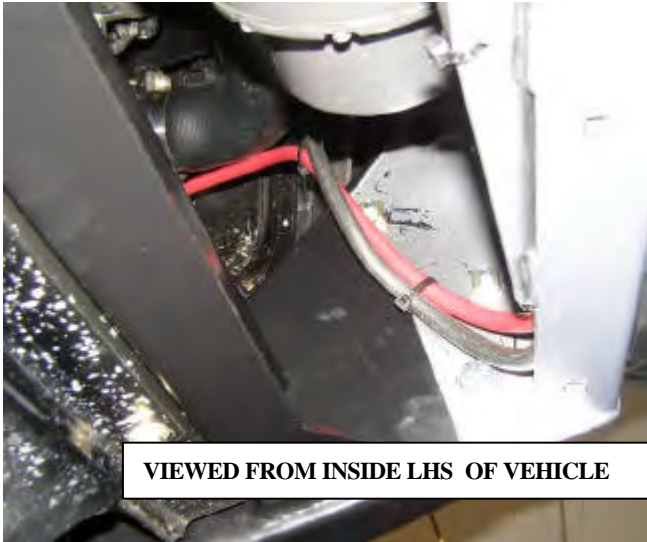

VIEWED FROM INSIDE LHS OF VEHICLE

**62. When bar is secured to mounting bracket assembly, connect winch cables to battery and cable tie cables together to clear of all moving parts, sharp edges and hot parts.**



**63. Lastly refit skid pan back to original rear bolts ( finger tighten ) and align front holes with holes in lower section of bar.**

**64. Place packer in between skid pan and lower section of bar and secure using original 8mm bolts from vehicle.**

**65. When all bolts are fitted, tighten to torque specifications.**



**66. If the bar is going to be fitted as a non winch bar, a cover panel is supplied in bolt kit with the 6mm hardware, being two stainless steel pan head bolts, 6mm flange nuts and rubber extrusion which is fitted around the outer edge of the panel.**





**67. If you are not having a winch fitted to the bar, fit number plate to bar as per photo using 6mm hardware.**

