



FITTING INSTRUCTIONS

JEEP CHEROKEE GRAND WJ

PRODUCT NUMBER

3450100

WARNING

FOR VEHICLES EQUIPPED WITH SRS AIRBAG
WHEN INSTALLED IN ACCORDANCE WITH THESE INSTRUCTIONS, THE FRONT PROTECTION BAR DOES NOT AFFECT OPERATION OF THE SRS AIRBAG.

TAKE NOTE OF THE FOLLOWING:

- **THIS PRODUCT MUST BE INSTALLED EXACTLY AS PER THESE INSTRUCTIONS USING ONLY THE HARDWARE SUPPLIED.**
- **IN THE EVENT OF DAMAGE TO ANY BULL BAR COMPONENT, CONTACT YOUR NEAREST AUTHORISED ARB STOCKIST. REPAIRS OR MODIFICATIONS TO THE IMPACT ABSORPTION SYSTEM MUST NOT BE ATTEMPTED.**
- **DO NOT USE THIS PRODUCT FOR ANY VEHICLE MAKE OR MODEL, OTHER THAN THOSE SPECIFIED BY ARB.**
- **DO NOT REMOVE LABELS FROM THIS BULL BAR.**
- **THIS PRODUCT OR ITS FIXING MUST NOT BE MODIFIED IN ANY WAY.**

IMPORTANT

- 1 **This winch bumper is suitable for Warn 8,000lb, 9,000lb & 9,500 low-mount winches only.**

WHEN FITTING THIS BULL BAR TO 1998 TO 2000 MODELS ONLY. IT IS RECOMMENDED THAT THE VEHICLES HYDRAULIC COOLING SYSTEM BE UPGRADED TO 2001 TO 2003 SPECIFICATION.

INSTALLATION OF THIS BULL BAR TO THE EARLIER MODELS WITHOUT THE COOLING SYSTEM UPGRADE MAY RESULT IN THE VEHICLE RUNNING HOTTER THAN NORMAL.

CONSULT YOUR NEAREST JEEP DEALER FOR PARTS REQUIRED.

FITTING KIT NUMBER 6171463

| USE | PART No | QTY | DESCRIPTION |
|--|----------|-----|-----------------------------|
| IMPACT ABSORBERS TO CHASSIS RAILS | 6151232 | 6 | BOLT M10 x 30mm |
| | 4581040 | 6 | WASHER FLAT M10 |
| | 4581048 | 6 | WASHER SPRING M10 |
| | 6151022 | 4 | BOLT M8 x 25MM |
| | 4581044 | 4 | WASHER FLAT M8 |
| | 4581046 | 4 | WASHER SPRING M8 |
| | 3756207 | 2 | BRACKET CAPTIVE NUT |
| | 6151302 | 4 | M10 CAGED NUT |
| | 3193666 | 2 | PLATE CAPTIVE NUT |
| | 3756213L | 1 | IMPACT ABSORBER |
| | 3756213R | 1 | IMPACT ABSORBERS |
| BULL BAR TO IMPACT ABSORBERS | 6151045 | 6 | BOLT M10 x 25mm |
| | 4581048 | 6 | WASHER SPRING M10 |
| | 4581040 | 6 | WASHER FLAT M10 |
| | 6151026 | 2 | NUT M10 |
| TO BOLT BUFFERS TO BULL BAR | 6151128 | 8 | NUT FLANGE M6 |
| CONTROL BOX BRACKET | 6151021 | 2 | BOLT M8 x 20mm |
| | 4581044 | 2 | WASHER FLAT M8 |
| | 3756209 | 1 | CONTROL BOX BRACKET |
| | 6151132 | 2 | NUT FLANGE M8 |
| NUMBER PLATE BRACKET | 6151017 | 4 | BOLT M6 x 16mm |
| | 6151046 | 4 | WASHER FLAT M6 |
| | 6151128 | 4 | NUT FLANGE M6 |
| | 3751451 | 1 | NUMBER PLATE BRACKET |
| BUFFERS AND INDICATORS | 3500170 | 1 | BUFFERS KIT |
| | 3500080 | 1 | ARB INDICATORS |
| 8-90001b WINCH TO PAN | 4581040 | 4 | WASHER FLAT 3/8"x 1" |
| | 180302 | 6 | CABLE TIES |
| WINCH PAN COVER | 6191001 | 1 | EXTRUSION RUBBER |
| | 6521036 | 1 | PANEL WINCH COVER |
| | 6151256 | 2 | SCREW BUTTON HEAD M6 x 16mm |
| | 6151128 | 2 | NUT FLANGE M6 |
| PLASTIC INNER GUARDS | 6151017 | 4 | BOLT M6 x 16mm |
| | 6151046 | 4 | WASHER FLAT M6 |
| | 6151128 | 4 | NUT FLANGE M6 |
| | 6151143 | 6 | SCREWS SELF DRILL |
| AIR DEFLECTOR | 3314452 | 1 | AIR DEFLECTOR |
| | 6151017 | 3 | BOLT M6 X 16mm |
| | 6151128 | 3 | NUT M6 - FLANGE |
| | 4581072 | 3 | WASHER M6 - FLAT |

TOOLS REQUIRED

1 BASIC TOOL KIT, DRILL, 1/2" DRILL BIT. 3/4" LONG REACH SOCKET (IF DRIVING LIGHTS ARE TO BE FITTED).

ASSEMBLY SEQUENCE FOR BULL BAR INSTALLATION.



1. Remove bumper bar and tow bracket from the vehicle.
2. Cherokee Grand Limited has grille and bumper as one piece, where Laredo has a chrome grille and separate bumper bar.
3. If your vehicle is the Limited, your choice is to either, separate grille from bumper bar by cutting with a keyhole saw, or purchasing a Laredo grille, part no. 55155921AA.
4. Photos supplied for cutting grille apart (refer page 6).
5. Once front of vehicle is stripped, spray paint satin black using a pressure pak can. This is done to hide vehicle colour that shows when bar is fitted to vehicle.



6. Using a hammer, flatten lip over under front crossmember on both sides of vehicle so impact absorbers can be mounted flush against chassis of vehicle.
7. Remove three bolts securing air deflector and place aside. Remove two forward most bolts securing bash plate to body.



8. Position impact absorber over aperture of front crossmember and temporarily clamp to vehicle using vice grips.



9. Preassemble captive nut bracket and caged nuts (see diagram), then insert captive assembly through front of impact absorber into vehicle crossmember aperture and align with holes in bottom of chassis.
10. From underneath vehicle, fasten to chassis using 2 x M10 x 30mm bolts with flat and spring washers and using existing bash plate bolt and captive nut.



APERTURE
BEHIND
IMPACT
ABSORBER

CAPTIVE
NUT

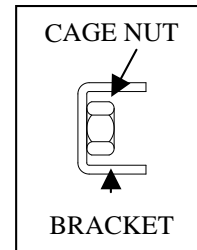

11. Drill 8mm holes through crossmember return using impact absorber holes as template.

(WARNING: BEWARE OF AIRCONDITIONING LINES AND WIRING LOOMS WHEN DRILLING.)



Fit 8mm captive nut plate behind crossmember return and align with 8mm drilled holes.



Using M8 x 25mm bolts, flat and spring washers, fasten through impact absorber to 8mm captive nut plate. When all bolts are fitted, tighten firmly.



12. If fitting the **XP 9.5 winch**, remove the cover from the control box.

For any other winch, go to step 19.

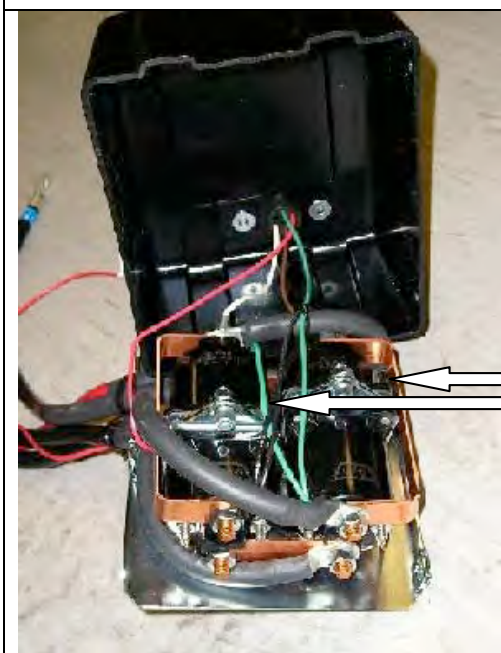

13. Remove the two cap screws, nuts and spacer washers that hold the four solenoids in place.

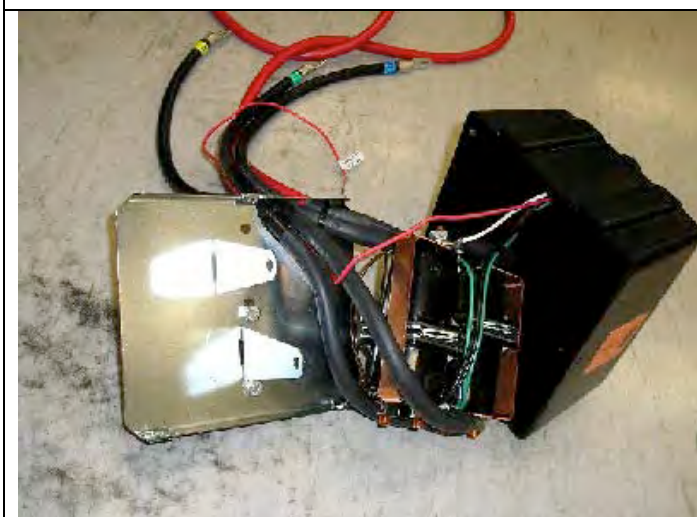

14. Remove the four solenoids from the base of the control box using the copper bus bar as an aid and hold to one side.

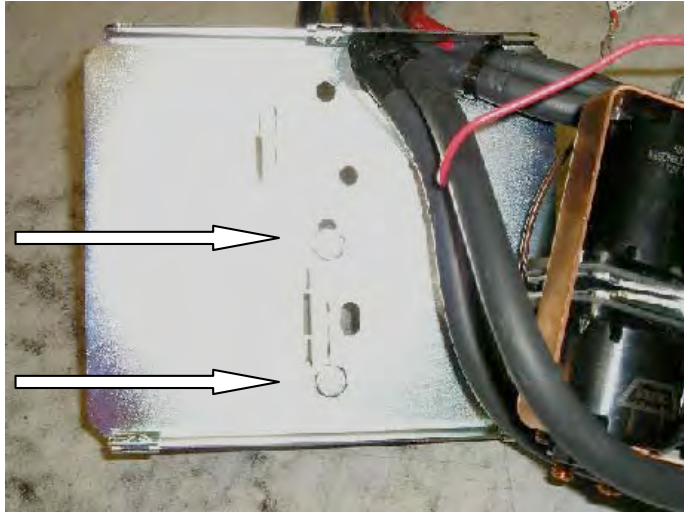

Before

15. Remove the two bolts in the base of the control box and reposition them into the more centralised holes

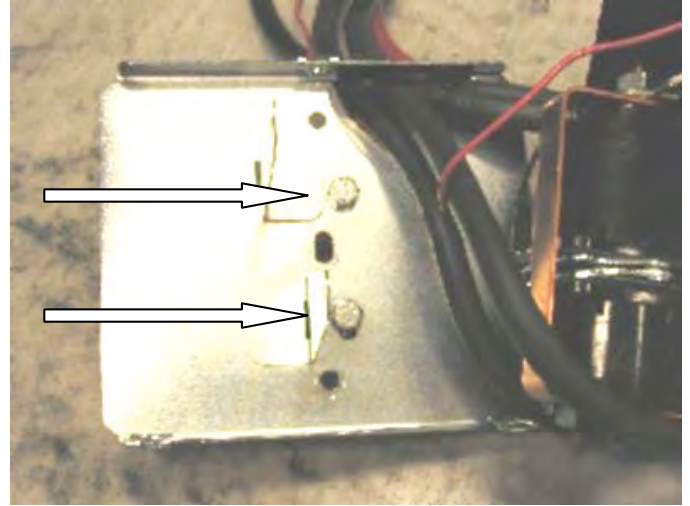

After

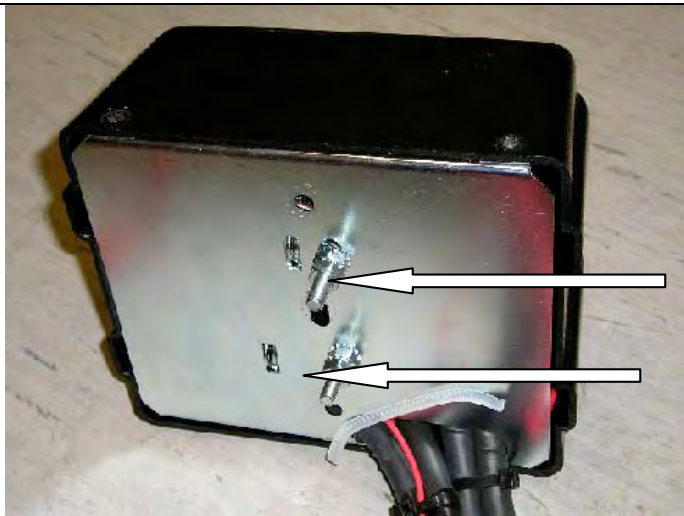

16. Place the 4 solenoids over the 2 metal stands that are facing upwards. Make sure they line up with the holes in the base.



17. Replace the 2 cap screws, washers and nuts removed in step 13 above into original holes.
18. Replace the black cover and refit the three cover screws (DO NOT OVER TIGHTEN)



(If using bar as a winch bar, follow as per instructions below.)

19. Fit control box bracket to bar using 8mm hardware.
20. Fit indicators into bar.
21. Fit number plate bracket to bar upward, or downward for non winch bar, using 6mm hardware.
22. Photo on left is number plate bracket in upward position.

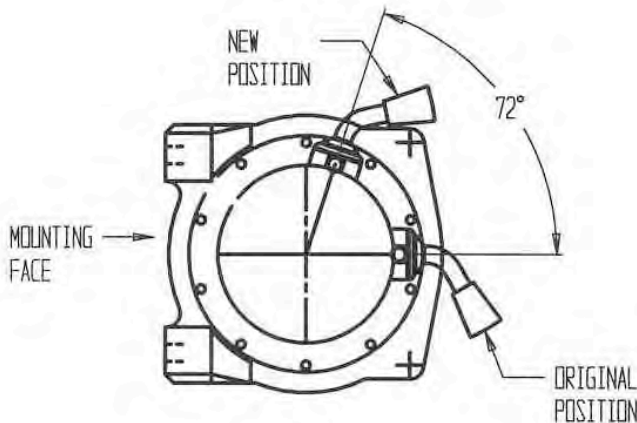

23. To place the clutch handle in the correct position, the winch gearbox must be rotated 72 degrees (2 hole spacings) in an anti-clockwise direction when viewed from gearbox end. Place the winch on its end and remove all gearbox bolts. Gently raise the gearbox just enough to rotate it. When the correct position is located, refit all bolts and tighten.

NOTE: Take care not to lift the assembly more than a couple of millimeters while rotating to correct position to avoid unmeshing the gears.

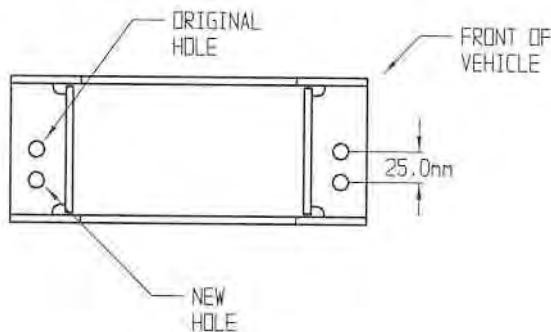

24. To fit roller fairlead to bull bar, you will need to drill 2 x 12mm holes into roller fairlead as per diagram.

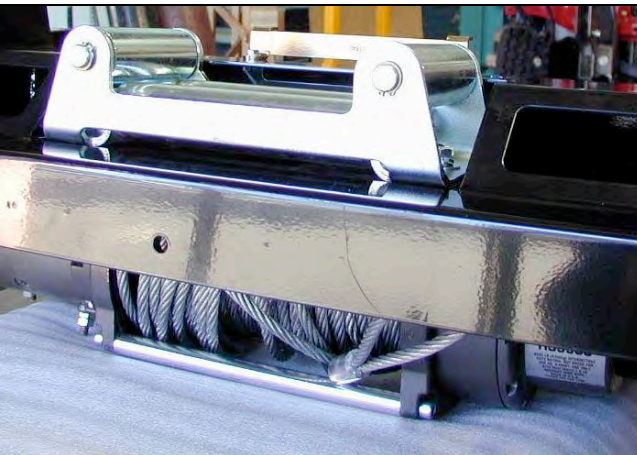

25. Once winch is rotated, position winch on bench face up.
26. Lower bull bar on top of winch and align holes.
27. Place roller fairlead in bar cutout over lower holes and fasten using 3/8" Warn hardware and 4 3/8" flat washers supplied in bolt kit.
28. To tighten bolts that hold roller fairlead to bar, remove vertical rollers using circlip pliers.
29. When all is positioned, tighten all bolts firmly and replace vertical rollers.

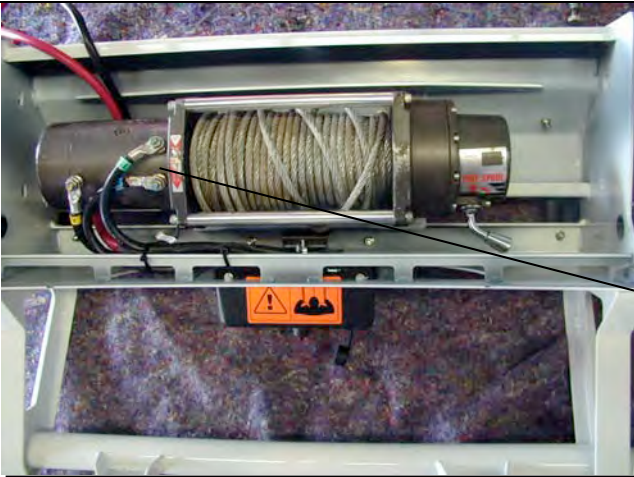

Photo above shows cable ties holding leads in place.

30. Fit control box to control box bracket and tighten firmly.
31. Pull wires through viewer cutout under control box and wire up as per Warn instruction manual.
32. Tie back cables clear of all moving parts with cable ties supplied.

33. Place ground earth lead under bolt of winch tension bar.
34. Fit buffers to bar using 6mm hardware.



Photo is from RHS of vehicle.

35. Lift bar into position between impact absorbers and bolt up using M10 x 25mm bolts, spring and flat washers. Finger tighten only. (Bolts fit from inside of bar.)
36. Adjust bar so that there is a 15mm gap around the periphery of the vehicle and securely tighten all remaining bolts throughout.
37. Next step is to lock pin the bar so there is no movement by drilling a 10mm hole on both sides of vehicle, and fasten with 10mm x 25mm bolts plus 10mm hardware.



Photo is from LHS of vehicle.

38. Wire main power leads to battery as per Warn instructions and cable tie leads securely from all moving parts with cable ties supplied.
39. Fit number plate to bar using 6mm hardware.
40. Pull winch cable through roller fairlead, and fit tow hook.
41. Connect the indicator looms to the existing indicator loom with the Scotchlocks supplied. Test to ensure the indicators function correctly.
42. Drill out plastic inner guard panel with 6mm drill bit using holes in bar return as template.
43. Secure with 6mm hardware.



44. Notch out plastic inner guard panel level with bottom of bar return, fold upward against bottom of vehicle crossmember and secure using self tapping screws.



45. If bar is to be a non winch bar, bolt cover panel to bar using 6mm hardware.

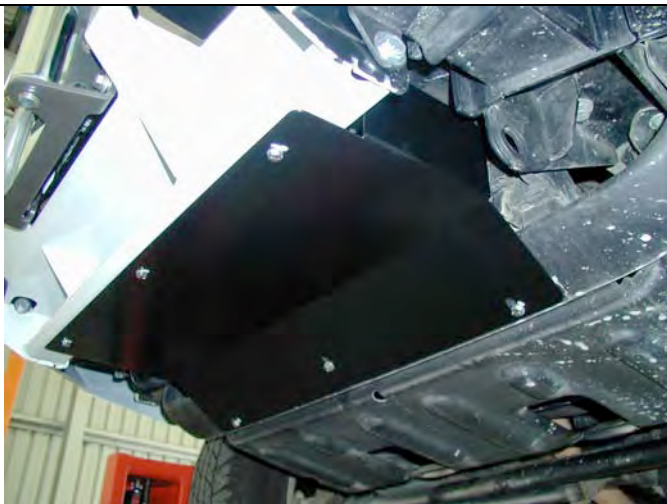

46. The air deflector is mounted beneath the bull bar using three of the existing bash plate bolts and three M6 bolts and hardware supplied in kit.



Carefully cut along joining line with a keyhole saw.

