



FITTING INSTRUCTIONS

ARB WINCH/NONWINCH BUMPER TO SUIT NISSAN PATHFINDER

2/99 ON

PRODUCT No. 3938020

WARNING

FOR VEHICLES EQUIPPED WITH SRS AIRBAG

WHEN INSTALLED IN ACCORDANCE WITH THESE INSTRUCTIONS, THE FRONT PROTECTION BAR DOES NOT AFFECT OPERATION OF THE SRS AIRBAG.

TAKE NOTE OF THE FOLLOWING:

- **THIS PRODUCT MUST BE INSTALLED EXACTLY AS PER THESE INSTRUCTIONS USING ONLY THE HARDWARE SUPPLIED.**
- **IN THE EVENT OF DAMAGE TO ANY BULL BAR COMPONENT, CONTACT YOUR NEAREST AUTHORISED ARB STOCKIST. REPAIRS OR MODIFICATIONS TO THE IMPACT ABSORPTION SYSTEM MUST NOT BE ATTEMPTED.**
- **DO NOT USE THIS PRODUCT FOR ANY VEHICLE MAKE OR MODEL, OTHER THAN THOSE SPECIFIED BY ARB.**
- **DO NOT REMOVE LABELS FROM THIS BULL BAR.**
- **THIS PRODUCT OR ITS FIXING MUST NOT BE MODIFIED IN ANY WAY.**

Note:

- 1 If fitting optional fog lights, fitting kit no. 9381FCK is required.**
- 2 This winch bumper is suitable for Warn 8,000lb, 9,000lb & 9,500HS winch only.**

Tools Required

10, 12,13, 14, 18, 19mm Spanners and Sockets. Phillips head screwdriver , Sharp Knife.

Drill and 6.5mm or ¼” Bit. Black silicone.

FITTING KIT No. 6171387, 6171391, 6171364

| USE | PART No | QTY | DESCRIPTION |
|-----------------------------------|----------|-----|------------------------------|
| BUFFER FITTMENT | 6151128 | 17 | NUT FLANGE M6 |
| | 3162158 | 1 | BUFFER LOWER |
| | 3162153 | 1 | BUFFER LHS |
| | 3162154 | 1 | BUFFER RHS |
| LIGHT SURROUNDS TO BAR | 3162156 | 1 | LIGHT SURROUND LHS |
| | 3162157 | 1 | LIGHT SURROUND RHS |
| CHROME TUBE FITTMENT | 6151255 | 2 | BOLT M12 X 40mm |
| | 4581049 | 2 | WASHER FLAT M12 |
| | 4581050 | 2 | WASHER SPRING M12 |
| | 6131174 | 1 | CHROME TUBE |
| MOUNT ASSY TO VEHICLE | 3751859L | 1 | BRACKET IMPACT ABSORBER LHS |
| | 3751859R | 1 | BRACKET IMPACT ABSORBER RHS |
| | 4581011 | 2 | WASHER FLAT 27x12x4mm |
| WING BRACE BAR TO VEHICLE | 3756195L | 1 | BRACE WING |
| | 3756195R | 1 | BRACE WING |
| | 6151256 | 2 | BOLT M6 BUTTON HEAD S/STEEL |
| | 4581072 | 2 | WASHER M6 x 19mm |
| | 6151017 | 2 | BOLT M6 x 16mm HEX HEAD |
| | 6151128 | 4 | NUT M6 FLANGE |
| | 4581072 | 2 | WASHER 19x7x1.6mm |
| WINCH | 4581044 | 4 | WASHER 3/8" |
| CONTROL BOX FITMENT | 3756220 | 1 | CONTROL BOX BRACKET |
| | 6151017 | 2 | BOLT M6 X 16MM |
| | 6151128 | 4 | NUT FLANGE M6 |
| WINCH COVER FITTMENT | 6151128 | 2 | NUT FLANGE M6 |
| | 6151256 | 2 | SCREW M6 S/STEEL BUTTON HEAD |
| | 6191001 | 1 | WINCH COVER EXTRUSION |
| | 6521031 | 1 | WINCH COVER |
| | 4581035 | 2 | WASHER M6 |
| RUBBER EXTRUSION FITMENT | 6821116 | 14 | SQUARE PLASTIC PLUG |
| | 6151176 | 14 | SCREW SELF TAPPING 12mm 8G |
| | 6191002 | 2 | EXTRUSION |
| | 3193649 | 2 | MOUNT STRIPS |
| WINCH BUMPER TO MOUNT ASSEMBLY | 6151255 | 6 | BOLT M12 X 40mm |
| | 4581050 | 6 | WASHER SPRING M12 |
| | 4581007 | 6 | WASHER FLAT M12 LARGE |
| CB | 3162152 | 2 | PLASTIC PLUG DIA16 |
| ROLLER FAIRLEAD FITTMENT | 4581049 | 4 | WASHER FLAT M12 |
| NUMBER PLATE FITTMENT | 6151017 | 2 | BOLT M6 X 16mm |
| | 6151128 | 2 | NUT FLANGE M6 |
| | 6781408 | 1 | TAPE DOUBLE SIDED |
| WIRING | 180302 | 10 | CABLE TIE |

ASSEMBLY SEQUENCE FOR WINCH BUMPER.

1.

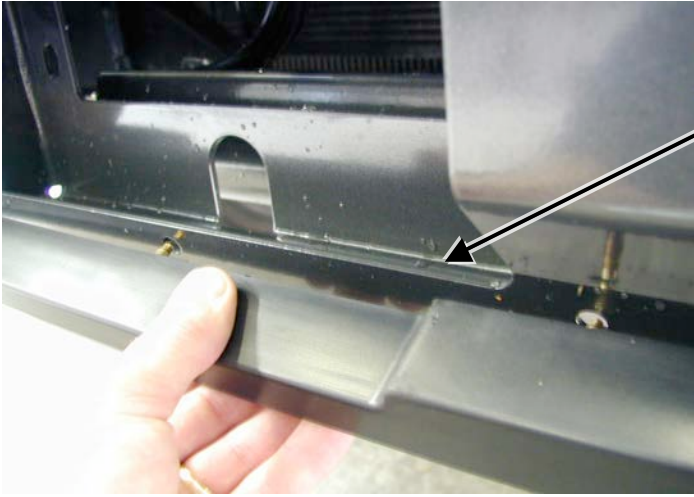

1. Position the lower buffer on the winch bumper and assemble using the M6 flange nuts.

2.



1. Insert the side buffers through the holes and fix using the M6 flange nuts.

3.



1. Glue the light surrounds to the bar using a silicone based rubber adhesive. Run the bead along the cavity on the rear side of the part. Position the surround to align the inside edge with the buffer and concentric to the light.
2. Wipe off any adhesive on the front face of the bar. Allow adhesive to cure before continuing.
3. If fitting optional fog lights, do so at this stage.

ASSEMBLY SEQUENCE FOR WINCH BUMPER.

4.



1. Push the top chrome tube through the hole in the buffer and fasten using the M12 x 40mm bolts, washers and spring washers.

5.



1. Remove the bumper bar.

1. Remove inner guard trims, left and right.
2. Remove Tow Hooks.
3. Remove Impact Absorbers.

NOTE: Set aside all original mounting hardware and inner guard trims.

6.

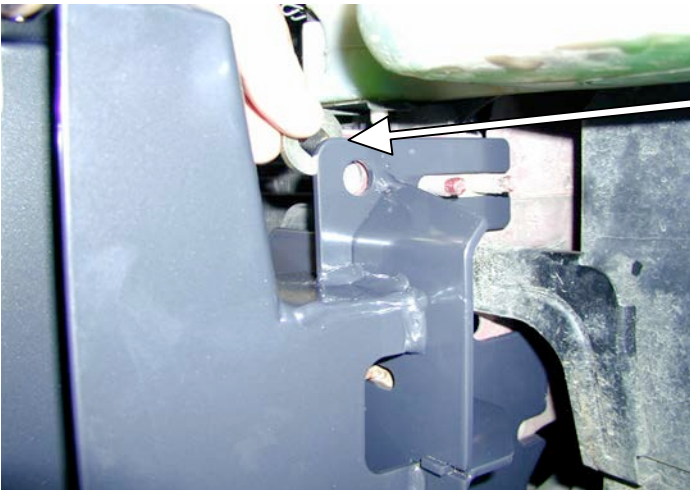

1. Mount the Impact Absorber brackets to each side of the chassis using original fasteners.
2. Fit spacer washer 27 x 12 x 4mm to top hole of bracket and fasten.

ASSEMBLY SEQUENCE FOR WINCH BUMPER.

7.

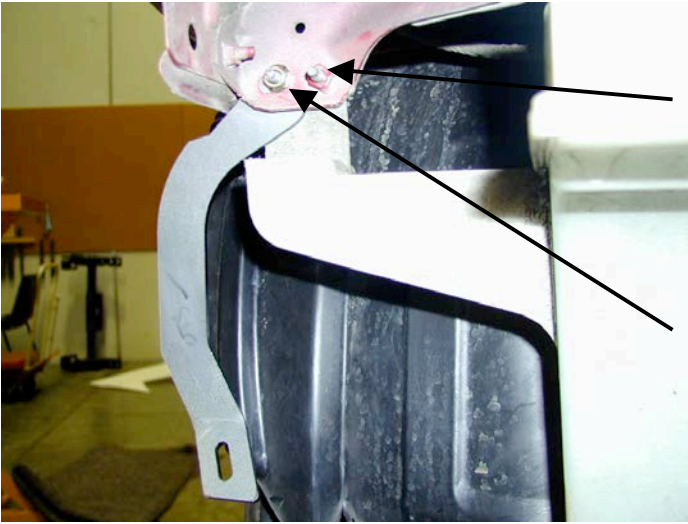

1. Fasten the wing braces to the vehicle using M6 Hex bolts, washers and flange nuts.
2. On the drivers side undo washer bottle and carefully cut off retaining hook with a sharp blade.
3. Pass the wing support brace between the bottle and the body aligning the holes.
4. Replace the original bolt, clamping the brace in place.
5. Using a 6.5mm or ¼" drill, drill through washer bottle bracket using the brace hole as a guide.
6. Fasten with M6 Hex head bolt and flange nut.

Note: - On passenger side use panel washers 19x7x1.6mm

8.

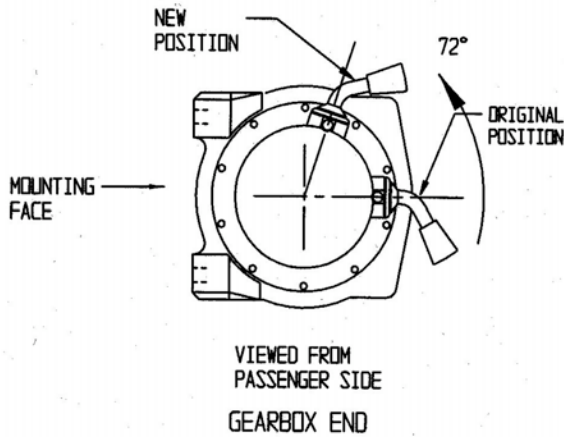

(If fitting the winch.)

1. To place the winch clutch handle in a convenient location the winch gearbox must be rotated 2 hole spacings, 72 degrees, in an anti-clockwise direction when viewed from the gearbox end. Place the winch on its end and remove all gearbox bolts. Gently raise the gearbox just enough to rotate it. Do not completely remove the gearbox and avoid damaging the gasket. Refit all bolts and tighten.

NOTE: Take care not to lift the assembly more than a couple of millimetres while rotating to the desired position to avoid unmeshing the gears.

9.

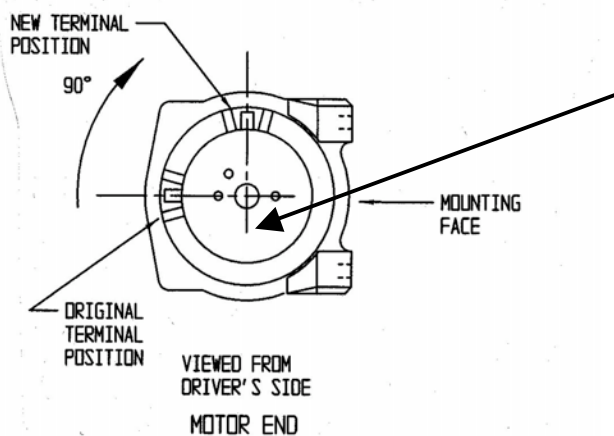

1. To place the winch motor in the correct location the winch motor must be rotated 90 degrees, in a clockwise direction when viewed from the motor end. Place the winch on its end and remove the 2 motor retaining bolts. Gently raise the motor just enough to rotate it. Do not completely remove the motor and avoid damaging the gasket. Refit all bolts and tighten.

NOTE: Take care not to lift the assembly more than a couple of millimetres while rotating to the desired position to avoid unmeshing the gears.

ASSEMBLY SEQUENCE FOR WINCH BUMPER.

10.



1. Bolt the winch and roller fair lead to the bar using the bolts supplied. The longer bolts are used for the two bottom holes through the roller fair lead.

11.



1. If fitting the **XP 9.5 winch**, remove the cover from the control box.

For any other winch, go to step 17.

12.

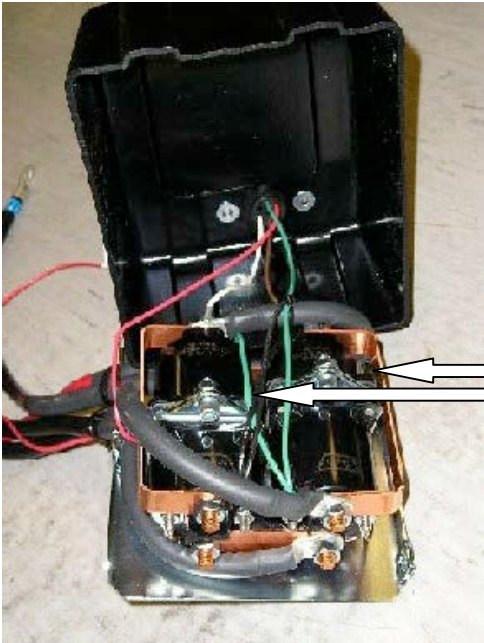

1. Remove the two cap screws, nuts and spacer washers that hold the four solenoids in place.

ASSEMBLY SEQUENCE FOR WINCH BUMPER.

13.

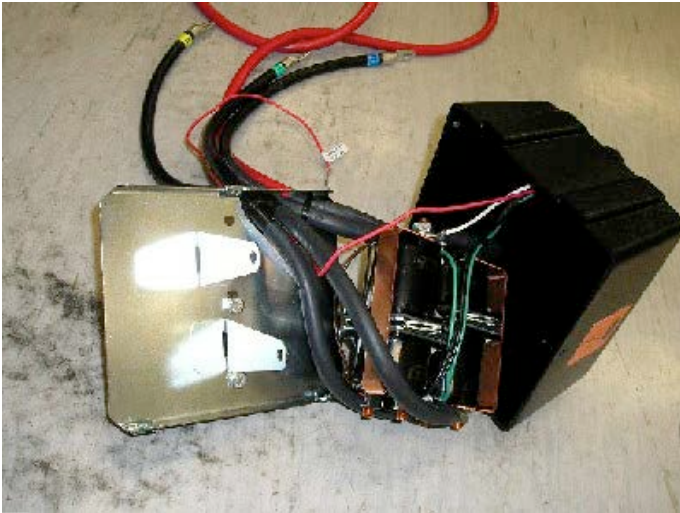

1. Remove the four solenoids from the base of the control box using the copper bus bar as an aid and hold to one side.

14.

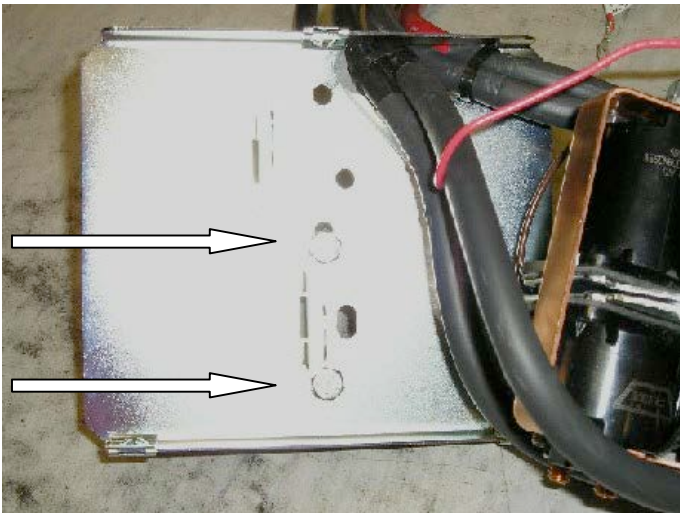

Before

1. Remove the two bolts in the base of the control box and reposition them into the more centralised holes

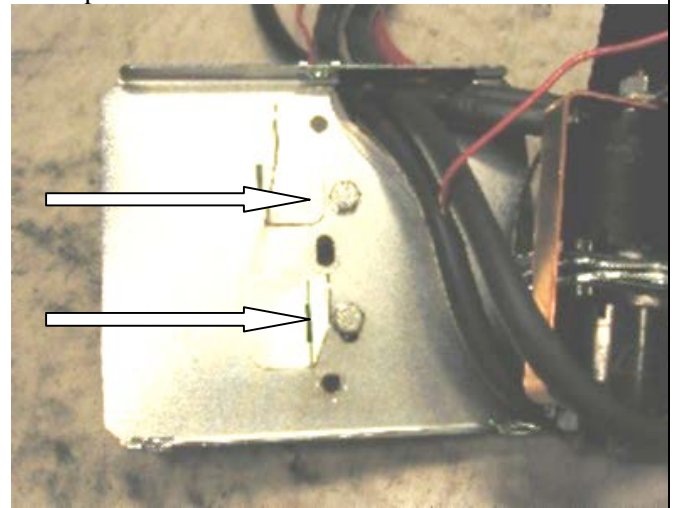

After

15.

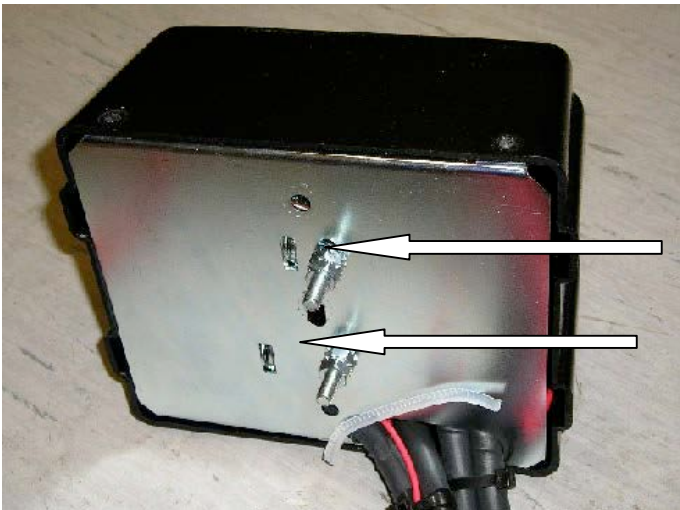

1. Place the 4 solenoids over the 2 metal stands that are facing upwards. Make sure they line up with the holes in the base.

ASSEMBLY SEQUENCE FOR WINCH BUMPER.

16.



1. Replace the 2 cap screws, washers and nuts removed in step 12 above into original holes.
2. Replace the black cover and refit the three cover screws (DO NOT OVER TIGHTEN)

17.

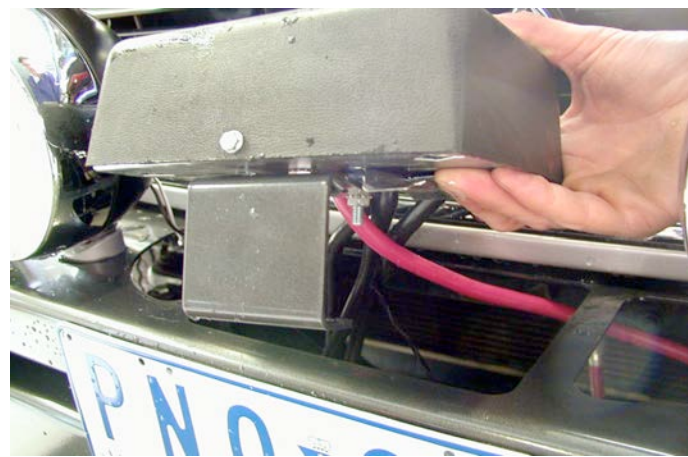

1. Install the winch and roller fairlead using bolts, nuts and spring washers supplied by Warn, and the 4 x 3/8" flat washers supplied in the bolt kit. Refer to Warn installation instructions for correct procedure. Adjust winch in slots until the winch is centralised in the bull bar.

1. Assemble the control box bracket to the control box using M6 flange nuts.
2. Mount the control box to the bar using M6 X 16 bolts and M6 flange nuts.

NOTE: The gearbox is on the passenger side for the 8,000lb and 9,000lb. The cable spools from the bottom for the two winches mentioned.

18.



(If not fitting winch)

1. Wrap rubber extrusion around winch cover.
2. Place washers over the winch cover fixing holes located on the top middle face of the winch bumper.
3. Place the winch cover on top of the winch bumper inline with the mount holes.

Bolt together using the M6 button head stainless steel screws and M6 nuts.

ASSEMBLY SEQUENCE FOR WINCH BUMPER.

19.



With winch



Without winch

(If fitting with winch.)

1. Peel off one side of the double sided tape and adhere to the top rear side of the number plate. Note: Clean the adhering surfaces before applying tape with an alcohol solvent.
2. Peel off the other side of the tape and bolt to the winch bumper with the M6 X 16mm bolts and M6 flange nuts through the lower holes of the number plate.
3. Press firmly to the top of the number plate so the tape can properly adhere.

(If not fitting with winch.)

1. Bolt the number plate through the top holes using M6 X 16mm bolts and M6 flange nuts.

If desired the double sided tape can be used down the sides of the number plate.

20.

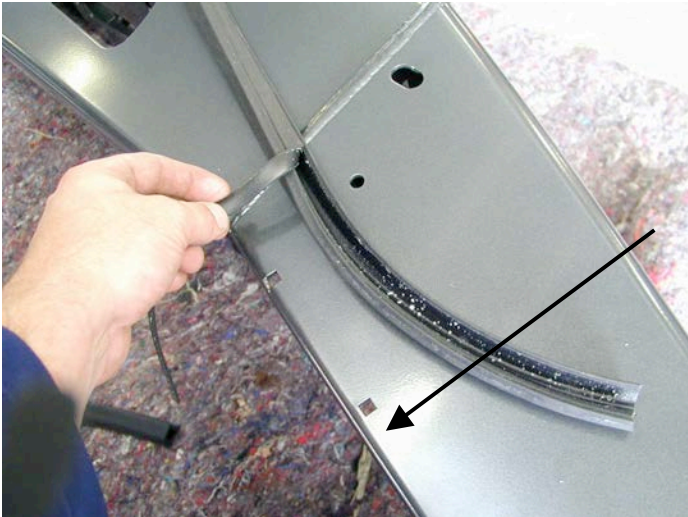

1. The rubber extrusion contains a support section to assist in the moulding. Remove this section by tearing at one end. Discard this section.
2. Insert the square plastic plugs into the square holes on the top face of the wing.

21.



1. Insert the mount strips inside the channel section of the rubber extrusion. Make sure the flap section is on the outer side. Allow generous even amounts of excess at either end of the strip so that it can be trimmed later.

ASSEMBLY SEQUENCE FOR WINCH BUMPER.

22.



1. Using a Philips head screw driver or cordless drill with a Philips head tip fix the extrusions to the top of the wings using the self tapping screws.

23.



1. Using a sharp knife cut the excess rubber in line with the inside end of the wing. Only cut the inside excess, the other end will be cut when the winch bumper is fitted.

24.

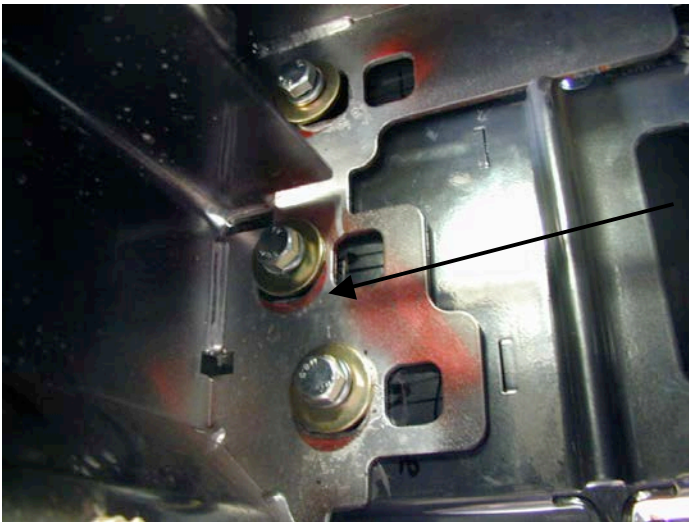

1. With the aid of another person carefully place the bar on the mounting brackets.
2. Horizontally and vertically align the bar to the body and fasten using the six M12 x 40mm bolts, large washers and M12 spring washers. Tighten all bolts so as the large washer deforms inside the rectangular cutout.

ASSEMBLY SEQUENCE FOR WINCH BUMPER.

25.



1. There are two diameter 16 holes located on the top face of the bar. If no CB aerials are fitted the holes can be covered with the plastic plugs provided in the fitting kit.
2. Place the ARB logo on the front face of the bar in the indentation.

26.



(If fitting with winch)

1. Feed the winch cable through the roller fair lead. Mount the hook to the end of the cable.

27.



1. To replace inner guard trims, reposition on the vehicle and mark out the edge of the bullbar wing
2. Using a sharp knife or scissors trim and refit the guard allowing enough to drill and position to the bar.

Note: - The trim will sit between the wing brace and the bullbar wing.

ASSEMBLY SEQUENCE FOR WINCH BUMPER.

28.



1. Trim off excess plastic as shown.
2. With the trim between the brace and the wing mark, via the hole in the wing, mark with a felt tip pen or a scribe.
3. Remove the trim and drill using 6.5mm or ¼" drill bit.
4. Reposition on the vehicle and fasten using dome head s/steel bolts and flange nuts.

29.

If fitting fog lights, wire the fog lights as described in the fog light fitting instructions

The fog lights can be adjusted to desired angles by the adjustment bolts located at the back of the light insert. When adjustment is finalised be sure to retighten the fog light bolts.

30. **(If fitting with winch)**

Connect the winch control box cables to the winch motor. Refer to the Warn handbook for additional information. Connect the long winch + & - cables to the vehicle after the bar is installed.

Refer to the Warn winch manual for vehicle wiring instructions.

Ensure that these cables are installed well clear of sharp, hot or moving objects. Secure the winch cables to the vehicle and winch bumper with the supplied cable ties.