

ARB FITTING INSTRUCTIONS

ARB WINCH / NON-WINCH BUMPER TO
SUIT LEXUS LX470 IFS & LANDCRUISER
09/2002 ON

PRODUCT No. 3913160
5100060 Top Tube Kit
5100160 Buffer Kit – With hole (required when fitting Top Tube)
5100170 Buffer Kit – With no hole

Fitting Kit No 6172353

WARNING

FOR VEHICLES EQUIPPED WITH SRS AIRBAG

**WHEN INSTALLED IN ACCORDANCE WITH THESE INSTRUCTIONS, THE
FRONT**

PROTECTION BAR DOES NOT AFFECT OPERATION OF THE SRS AIRBAG.

TAKE NOTE OF THE FOLLOWING:

- **THIS PRODUCT MUST BE INSTALLED EXACTLY AS PER THESE INSTRUCTIONS USING ONLY THE HARDWARE SUPPLIED.**
- **DO NOT USE THIS PRODUCT FOR ANY VEHICLE MAKE OR MODEL, OTHER THAN THOSE SPECIFIED BY ARB.**
- **DO NOT REMOVE LABELS FROM THIS BULL BAR.**
- **THIS PRODUCT OR ITS FIXING MUST NOT BE MODIFIED IN ANY WAY.**

OPTIONAL LIGHT SETS TO SUIT THIS PRODUCT:

- ARB 6821201 Fog Light Kit Suit 3163015
- Up to IPF 900 SERIES FOG OR DRIVING LIGHT SETS

IMPORTANT

This winch bumper is suitable only for Warn 9000lb and 9500lb winch only.

USE	PART No	QTY	DESCRIPTION
MOUNT ASSY TO VEHICLE	6151257	2	BOLT M12 X 200mm
	4584298	4	WASHER FLAT M14
	4721469	2	TUBE PACKER
	5846282	2	CHANNEL PACKER
	4581050	2	WASHER SPRING M12
	6151189	2	NUT M12
	6151258	2	BOLT M14 X 80mm
	4581052	4	WASHER SPRING M14
	5846401	4	PACKER 10mm THICK
	3756202	1	MOUNT ASSY.
WINCH BUMPER TO MOUNT ASSY	6151255	6	BOLT M12 X 40mm
	4581050	6	WASHER SPRING M12
	4581007	6	WASHER FLAT M12 LARGE
WINCH	4581044	4	WASHER 3/8"
BUFFER FITMENT (5100160 Required if fitting top tube)	6151128	12	NUT FLANGE M6
	3162153	1	BUFFER LH
	3162154	1	BUFFER RH
BUFFER FITMENT (5100170 Required if not fitting top tube)	6151128	12	NUT FLANGE M6
	3162471L	1	BUFFER LH
	3162471R	1	BUFFER RH
BUFFER LOWER FITMENT	6151128	5	NUT FLANGE M6
	3162158	1	BUFFER LOWER
TOP TUBE FITMENT (5100060)	6151255	2	BOLT M12 X 40mm
	4581049	2	WASHER FLAT M12
	4581050	2	WASHER SPRING M12
	6131167	1	TOP TUBE
CONTROL BOX FITMENT	3756220	1	CONTROL BOX BRACKET
	6151017	2	BOLT M6 X 16MM
	6151128	4	NUT FLANGE M6
ROLLER FAIRLEAD FITMENT	6151255	2	BOLT M12 X 40mm
	4581050	2	WASHER SPRING M12
	4581049	4	WASHER FLAT M12
	6151189	2	NUT M12
WINCH COVER FITMENT	6151128	2	NUT FLANGE M6
	6151256	2	SCREW M6 S/STEEL BUTTON HEAD
	6191001	1	WINCH COVER EXTRUSION
	6521031	1	WINCH COVER
	4581304	2	WASHER FLAT M6 S/S

USE	PART No	QTY	DESCRIPTION
NUMBER PLATE FITMENT	6151017	2	BOLT M6 X 16mm
	6151128	2	NUT FLANGE M6
	6781408	1	TAPE DOUBLE SIDED
LIGHT HOUSING	3162467R	1	SURROUND FOG AND INDICATOR RHS
	3162467L	1	SURROUND FOG AND INDICATOR LHS
	3162468	2	INSERT FOG LIGHT SURROUND
	6151317	8	SCREW 8-18 X 5/8 PAN HEAD
LIGHT HOUSING FITMENT	3163015	1	COMBINATION LIGHT SURROUND KIT
	6821151L	1	TURN SIGNAL/CLEARANCE LIGHT
	6821151R	1	TURN SIGNAL/CLEARANCE LIGHT
CB & HEADLIGHT WASHERS	3162152	2	PLASTIC PLUG DIA16
	3162159	2	PLASTIC PLUG DIA 22
WIRING	6821152	2	TURN SIGNAL / CLEARANCE LIGHT LOOM
	180701	6	SCOTCH LOCK
	180302	10	CABLE TIE

Tools Required

10mm, 18mm, 19mm, 21mm Spanners and Sockets. Phillips head screwdriver.

Can of matt black spray paint, masking tape and masking paper, required on light coloured vehicles.

ASSEMBLY SEQUENCE

1.



1. Disassemble the mount assy. from the winch bumper by removing the transit bolts.
2. Remove the bumper bar and grill.
3. Remove the cross member and tow brackets.

2.



1. Insert the tube packers, one in each chassis arm.
2. Line the bottom of the tube to the bottom hole of the chassis rail. Rest the top of the tube to the front of the chassis rail. The tube should be angled forward.

3.

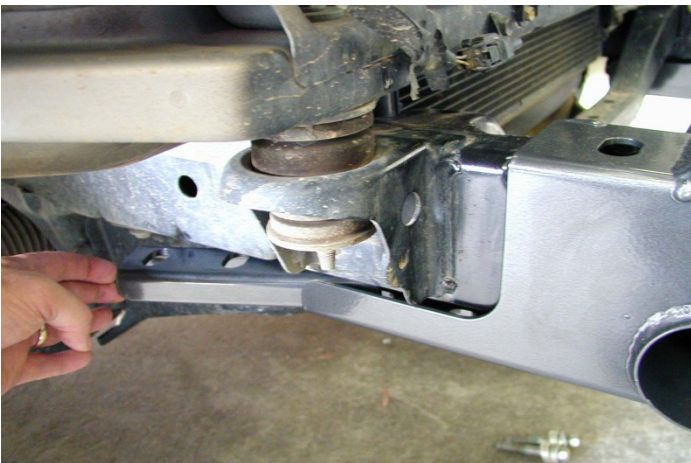

1. Slide the mount assy. over the chassis rails. Try not to shake the vehicle too severely as the tube packers may fall out of place.
2. Insert the channel packers from the rear. Make sure the hole correspond to the holes in the mount.
3. Push the entire mount as far back as possible.

ASSEMBLY SEQUENCE

4.



1. Using a long screwdriver insert it through the bottom hole so it passes through the tube packer. This may require a visual check from under the vehicle to see the position of the tube.
2. Using the screwdriver twist around until the packer is inline with the top hole.

5.



1. Insert the M12 X 200mm bolt through the top hole using one of the 10mm thick packers. Push through while removing the screwdriver from underneath until the bolt locates right through

6.



1. Fasten the rest of the mount using:
 - 2 M14 bolts removed earlier from tow bracket
 - 2 M14 bolts from fitting kit
 - 4 M14 flat washers
 - 4 M14 spring washers
 - 2 10mm thick packers
 - 2 M12 nuts
 - 2 M12 spring washers

NOTE: Assemble with the tow brackets.

ASSEMBLY SEQUENCE

7.

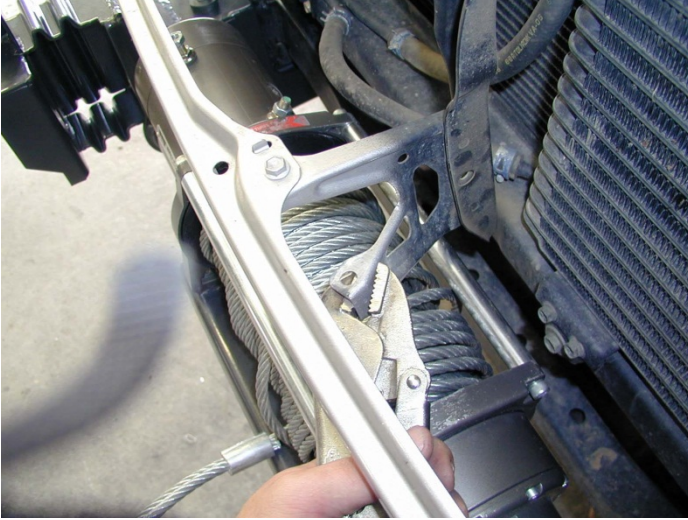

1. Using vice grips, multi grips or pliers bend back the bumper mounting arm approximately 30 – 40 degree's to clear bar when assembled.

8.

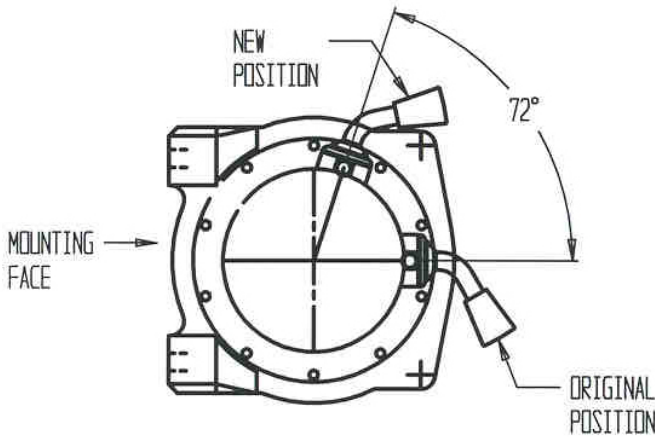

(If fitting with winch)

To place the clutch handle in a convenient location the winch gearbox must be rotated two hole spacings.

1. Place the winch on its end and remove all gearbox bolts.
2. Gently raise the motor just enough to rotate it.
3. Do not completely remove the motor and avoid damaging the gasket.
4. Refit and tighten all bolts.

NOTE: Take care not to lift the assembly more than a couple of millimetres while rotating to the desired position to avoid un-meshing the gears.

9.

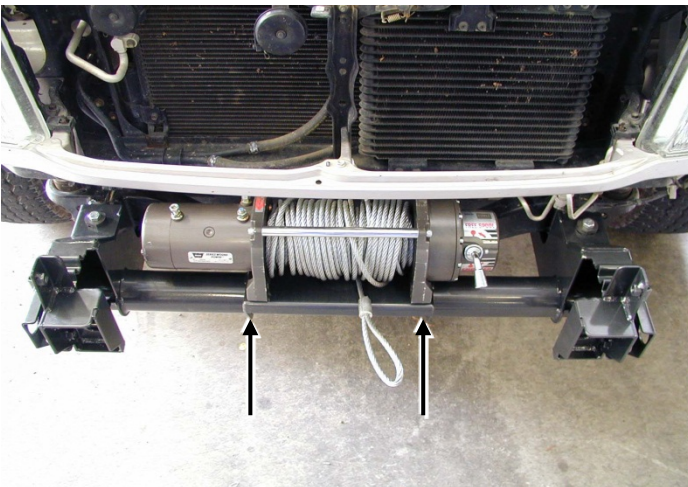

(If fitting with winch.)

1. Place the winch on the mount assy. as shown in picture.

Bolt from underneath using bolts supplied with winch. Refer to Warn installation instructions for correct procedure.

ASSEMBLY SEQUENCE

10.



1. It is recommended that on light coloured vehicles, the sheet metal area (the bolted flange) below the fender and the return flange under the headlamp and grille is painted matt black.
2. Ensure that the area to be painted is clean and free from wax and oils.
3. **IMPORTANT** Ensure the area to be painted is well masked to eliminate any overspray onto the vehicle.

11.



1. Position the lower buffer on the winch bumper and assemble using the M6 flange nuts.

12.



1. Fit the buffers. Buffer studs fit through the slots in the wings and the pan. Fasten using M6 flange nuts.

Note: This applies to both blank buffers and for those with the hole for optional frame.

CAUTION: DO NOT OVER TIGHTEN THE M6 NUTS AS YOU RISK PULLING THE STUDS OUT OF THE BUFFERS.

ASSEMBLY SEQUENCE

13.



IF FITTING TOP TUBE

1. Push the tube through the holes in the top of the bumper and fix using the M12 X 40mm bolts washers and spring washers.

NOTE:

Torque these M12 fasteners to 44Nm only (Critical)

14.



(If not fitting winch)

1. Wrap rubber extrusion around winch cover.
Place stainless steel washers over the winch cover fixing holes located on the top middle face of the winch bumper.
Place the winch cover on top of the winch bumper in line with the mount holes.
Bolt together using the M6 button head stainless steel screws and M6 nuts.

Go to step 16

15.



(If fitting with winch)

1. Install the roller fairlead using bolts, nuts and spring washers supplied by Warn, and the 4 x 3/8" flat washers supplied in the bolt kit. Refer to Warn installation instructions for correct procedure.

ASSEMBLY SEQUENCE

16.



Fitting with winch



Fitting without winch

(If fitting with winch.)

1. Peel off one side of the double sided tape and adhere to the top rear side of the number plate. Note: Clean the adhering surfaces before applying tape with an alcohol solvent.
2. Peel off the other side of the tape and bolt to the winch bumper with the M6 X 16mm bolts and M6 flange nuts through the lower holes of the number plate.
3. Press firmly to the top of the number plate so the tape can properly adhere.

(If not fitting with winch.)

1. Bolt the number plate through the top holes using M6 X 16mm bolts and M6 flange nuts.
2. If desired the double sided tape can be used down the sides of the number plate.

17.



1. Insert the six M12 x 40mm bolts with the large plate washers and spring washers to finger tight. The bolts screw from the inside of the upright.

NOTE: The bar mounts on the rear set of holes on the upright.

2. Using another person position the bar to line up the end of the wing to the wheel arch and the gap between the bar and mudguard is even. Tighten all bolts.

18.



(If fitting with winch)

1. Feed the winch cable through the roller fair lead. Mount the hook to the end of the cable.

If fitting the XP 9.5 winch go to step 19. For any other winch, go to step 25.

ASSEMBLY SEQUENCE

19.



1. Remove the cover from the control box.

20.

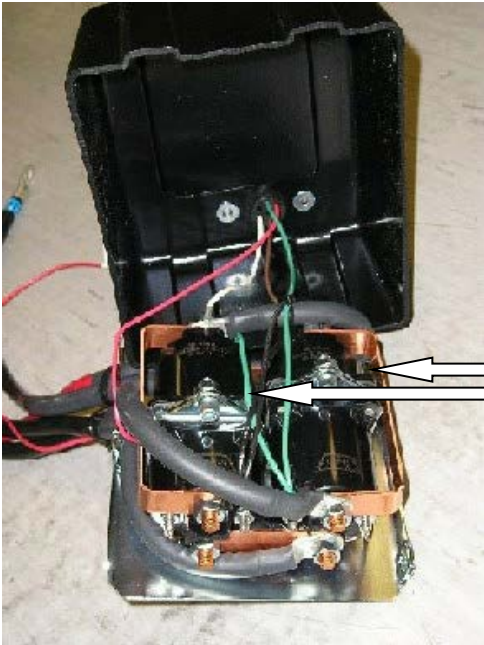

1. Remove the two cap screws, nuts and spacer washers that hold the four solenoids in place.

21.

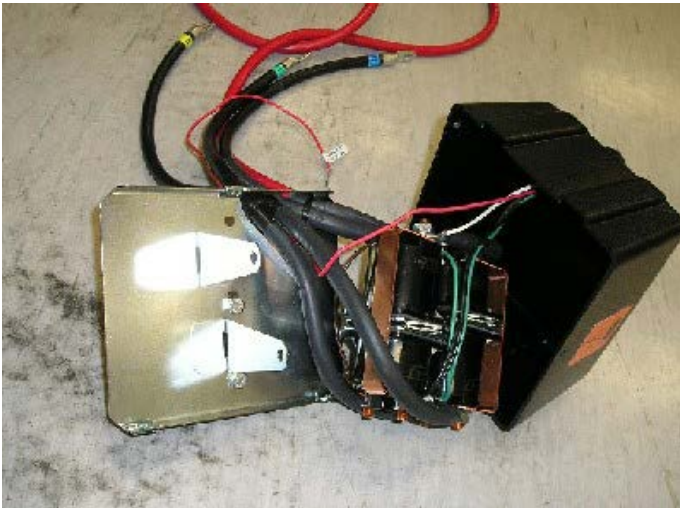

1. Remove the four solenoids from the base of the control box using the copper bus bar as an aid and hold to one side.

ASSEMBLY SEQUENCE

22.

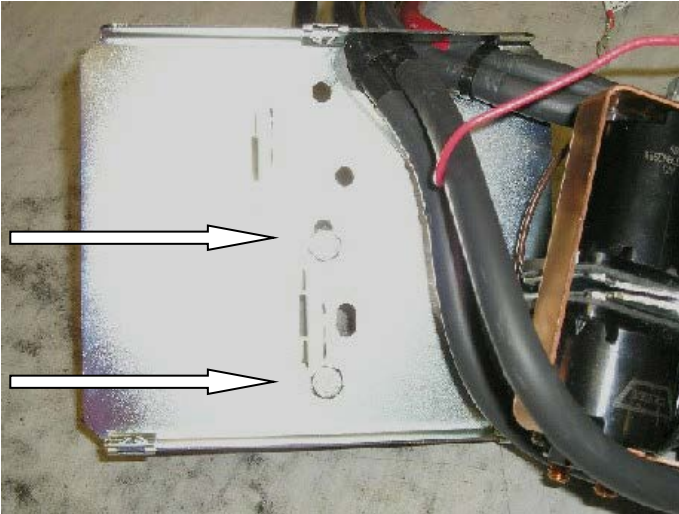

Before

1. Remove the two bolts in the base of the control box and reposition them into the more centralized holes

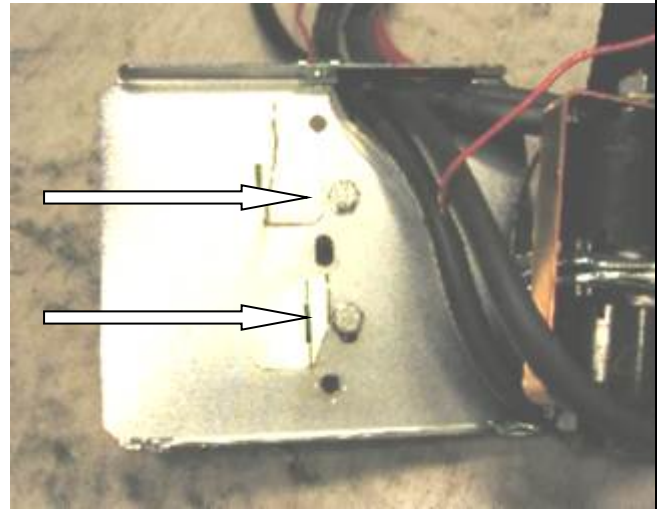

After

23.

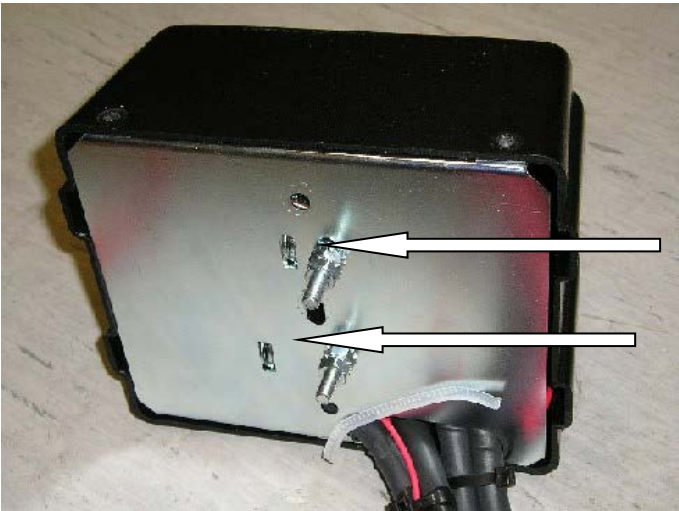

1. Place the 4 solenoids over the 2 metal stands that are facing upwards. Make sure they line up with the holes in the base.

24.



1. Replace the 2 cap screws, washers and nuts removed in step 20 above into original holes.
2. Replace the black cover and refit the three cover screws (DO NOT OVER TIGHTEN)

ASSEMBLY SEQUENCE

25.

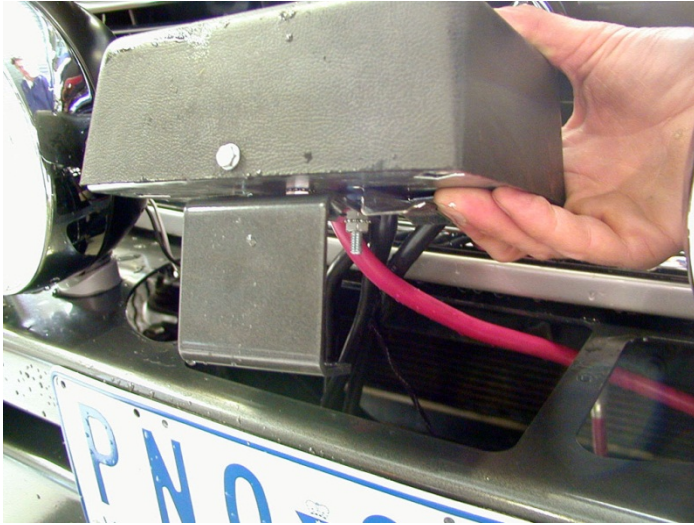

(If fitting with winch)

1. Assemble the control box bracket to the control box using M6 flange nuts.
2. Mount the control box to the bar using M6 X 16 bolts and M6 flange nuts.

26.

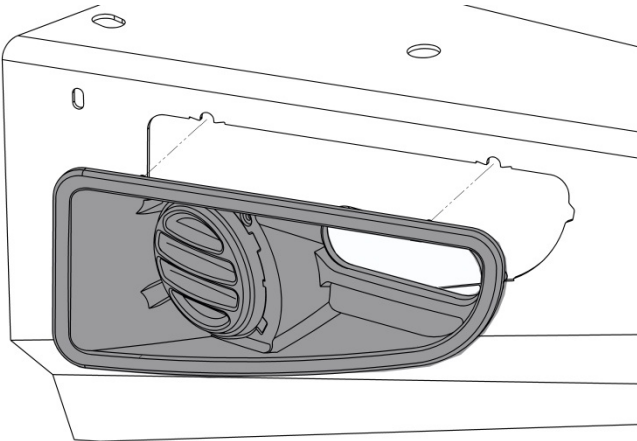

Assemble and install combination light surrounds (p/n 3163015) as per instructions no. 3786421 supplied with surround kit. Note: Optional fog lamps can be installed at this point as per fitting instruction no. 3783315 supplied with fog lamp kit no. 6821201. Wire the combination lamp to the vehicles indicator and clearance lamps.

Caution: Cable tie all cables together and keep all cables clear of sharp edges and moving parts.

27.



If fitted, headlight washers can be mounted through the Diameter 22 holes on the top face of the wing. Assemble using the existing mount clips. Two plugs are provided to cover the holes if there are no headlight washers on the vehicle.

There are two diameter 16 holes located on the top face of the bar. If no CB aerials are fitted the holes can be covered with the plastic plugs provided in the fitting kit.

Place the ARB logo on the front face of the bar in the indentation.

ASSEMBLY SEQUENCE

28.

(If fitting with winch)

Connect the winch control box cables to the winch motor. Refer to the Warn handbook for additional information. Connect the long winch + & - cables to the vehicle after the bar is installed. Refer to the Warn winch manual for vehicle wiring instructions.

Ensure that these cables are installed well clear of sharp, hot or moving objects. Secure the winch cables to the vehicle and winch bumper with the supplied cable ties.

29.

Wire the clearance / turn signal lights to the vehicle wiring.