



# FITTING INSTRUCTIONS

Part Number: **3423150**  
Product [SUMMIT COMBAR](#) TACOMA | 16ON AF20 8-10  
Description:  
Suited to **TOYOTA TACOMA 2016**  
vehicle/s:  
Optional **3500640 - ARB AUX Fog Light Adaptor**  
Fitting Kits: **3500530 - ARB AUX Fog Light Loom (non-factory fog lamp vehicles)**  
**3500680 - Fog Lamp Housing Clear Lens Kit**  
**3500590 - Fog Light Kit (LH&RH Lights)**  
**3500720 - SUMMIT BAR WINCH INSTALL KIT**

## WARNING

### REGARDING VEHICLES EQUIPPED WITH SRS AIRBAG;

When installed in accordance with these instructions, the front protection bar does not affect operation of the SRS airbag.

### ALSO, NOTE THE FOLLOWING:

- ◆ This product must be installed exactly as per these instructions using only the hardware supplied.
- ◆ In the event of damage to any bull bar component, contact your nearest authorised ARB stockist. Repairs or modifications to the impact absorption system must not be attempted.
- ◆ Do not use this product for any vehicle make or model, other than those specified by ARB.
- ◆ Do not remove labels from this bull bar.
- ◆ This product or its fixing must not be modified in any way.
- ◆ The installation of this product may require the use of specialized tools and/or techniques
- ◆ It is recommended that this product is only installed by trained personnel
- ◆ These instructions are correct as at the publication date. ARB Corporation Ltd. cannot be held responsible for the impact of any changes subsequently made by the vehicle manufacturer
- ◆ During installation, it is the duty of the installer to check correct operation/clearances of all components
- ◆ Work safely at all times
- ◆ Unless otherwise instructed, tighten fasteners to specified torque

# GENERAL CARE AND MAINTENANCE

By choosing an ARB Bar, you have bought a product that is one of the most sought after 4WD products in the world. Your bar is a properly engineered, reliable, quality accessory that represents excellent value. To keep your bar in original condition it is important to care and maintain it following these recommendations:

- Prior to exposure to the weather your bar should be treated to a Canuba based polish on all exposed surfaces. It is recommended that this is performed on a six monthly basis or following exposure to salt, mud, sand or other contaminants.
- As part of any Pre Trip Preparation, or on an annual basis, it is recommended that a thorough visual inspection of the bar is carried out, making sure that all bolts and other components are torqued to the correct specification. Also check that all wiring sheaths, connectors, and fittings are free of damage. Replace any components as necessary. This service can be performed by your local authorized ARB Stockist.

## ACCESSORIES:

- ◆ FITS ARB FOGLIGHT.
- ◆ FITS IPF 800, 900 SERIES & ARB INTENSITY (BOTH EXISTING AND NEW SMALLER).
- ◆ SUITS WINCHES WARN M8000, XD9, 9.5XP,9.5XDC,MAGNUM 8,10, ZEON 8,10 (ALL WINCHES STEEL OR SYNTHETIC ROPE), BUSHRANGER DV9TH,SEAL9.5TH, SMITTYBILT X20 10K.

## FITTING REQUIREMENTS

### REQUIRED TOOLS FOR FITMENT OF PRODUCT:

Basic Tool Kit	External Circlip pliers
1/2" and 1/4" socket set	Power Drill 13mm capacity
Dia 10 and 13mm drill bits	Non-permanent marker
Tape measure - metric	Low Tack Masking Tape
Multitool or Jig saw with blade to suit plastic cutting	Torque Wrench 9 – 77 Nm
File	Touch-up Paint Anti-Corrosion
Hacksaw	Black Spray Paint

### HAVE AVAILABLE THESE SAFETY ITEMS WHEN FITTING PRODUCT:

Protective eyewear



Hearing protection



**NOTE: 'WARNING' notes in the fitting procedure relate to OHS situations, where to avoid a potentially hazardous situation it is suggested that protective safety gear be worn or a safe work procedure be employed. If these notes and warnings are not heeded, injury may result.**

**FASTENER  TORQUE SETTINGS:**

SIZE	Torque Nm	Torque lbft
M6	9Nm	7lbft
M8	22Nm	16lbft
M10	44Nm	32lbft
M12	77Nm	57lbft

PARTS LISTING			
APPLICATION.	PART NO.	QTY	DESCRIPTION
FIT MOUNTS TO CHASSIS	3759744R	1	BRKT MNT ASSY STEEL TACOMA 16ON RH
	3759744L	1	BRKT MNT ASSY STEEL TACOMA 16ON LH
	3756794	1	BRKT TENSION TACOMA 05 RH
	3756794L	1	BRKT TENSION TACOMA 05 LH
	3759783	2	BRKT WING PANEL
	3194380	4	PACKER
	6151360	4	BOLT M12 x 1.75 x 35 Gd8.8 ZP
	6151428	4	NUT FLANGE M12 X 1.75 ZP
	4581007	10	WASHER FLAT, 1/2 x 1 1/2 x 4 SILVER TZP
	4581050	8	WASHER SPRING 1/2 x 3/16 x 3/16 ZP
	6151095	4	BOLT M12 x 1.25 x 35
	4581049	6	WASHER FLAT 1/2"
	6151135	4	NUT M12 x 1.25
	6151104	2	BOLT 1/2" UNC x 4"
	6151139	2	NUT 1/2" UNC NYLOC
FIT BAR TO MOUNTS	3423150	1	SUMMIT COMBAR TACOMA  16ON AF20 8-10
	6151360	6	BOLT M12 x 1.75 x 35 Gd 8.8 ZP
	6151357	4	BOLT SEMS M10 X 30 ZP Gd 8.8
	4581050	6	WASHER SPRING 1/2 x 3/16 x 3/16 ZP
	4581007	6	WASHER FLAT, 1/2 x 1 1/2 x 4 SILVER TZP
	6151428	6	NUT FLANGE M12 X 1.75 ZP
	6151321	4	NUT FLANGE M10 x 1.5 ZP
FIT LIGHTS AND MOULDINGS	3500710	1	GRILLE SPLIT PAN KIT
	5100200	1	BUFF KIT 2PCE FRONT SECTION KIT
	5100210	1	BUFF KIT 2PCE REAR UPRIGHT BAR KIT
	6821287	1	LAMP LED INDICATOR CLEARANCE KIT
	3163082	1	SURROUND ARB FOGLIGHT KIT
	6821116	4	GROMMET NYLON SNAP IN TYPE
	5848428	4	SHIM OVER RIDER 1.6MM

FIT STONE GUARDS	6523067	1	PANEL STONE GUARD TACOMA 16ON
	6523068R	1	PANEL WING TACOMA 16ON RH
	6523068L	1	PANEL WING TACOMA 16ON LH
	6151300	10	NUT CAGED M6 2.6-3.5
	6151301	4	NUT CAGED M8 3.3-4.7
	6151234	4	BOLT M8 x 1.25 x 25 Gd 8.8 BP
	6151213	10	BOLT M6 x 1.0 x 20 Gd8.8 BZ
	4581287	10	WASHER SPRING M6 x 2.5 x 1.6 BLK ZN
	4581047	4	WASHER SPRING M8 x 3/32 x 3/33 BLK ZN
	4581082	10	WASHER FLAT, M6 x 19 x 1.6 BZ
	4581307	4	WASHER FLAT, M8 x 20 x 2 BLK ZN
FIT WINCH COVER PANEL	6523091	1	PRESS FORM WINCH COVER PANEL  HILUX
	6151213	4	BOLT M6 x 1.0 x 20 Gd8.8 BZ
	4581287	4	WASHER SPRING M6 x 2.5 x 1.6 BLK ZN
	4584295	4	WASHER FLAT M6 X 12 X 1.3 BLK ZN
	6151128	4	NUT FLANGE M6 x 1.0 ZP
FIT LICENSE PLATE	3759488	1	BRACKET LIC PLATE FIXED LARGE RAD
	6151489	2	SCREW 10G x 5/8 SELF TAPPING
	6821189	2	GROMMET RND FC 1500 080 090
	6151213	3	BOLT M6 x 1.0 x 20mm Gd 8.8 BZ
	4581287	3	WASHER SPRING M6 x 2.5 x 1.6 BLK ZN
	4584295	3	WASHER FLAT M6 x 12 x 1.3 BLK ZN
	6151128	3	NUT FLANGE M6 x 1.0 ZP
MISCELLANEOUS	6191024	2	PINCH WELD 600mm
	3789455	1	TEMPLATE BUMPER CUT
	180302	8	CABLE TIE 4.8 x 180mm BLACK
	6151319	2	SCREW TEK 8g-18 x 32mm

## FITTING PROCEDURE

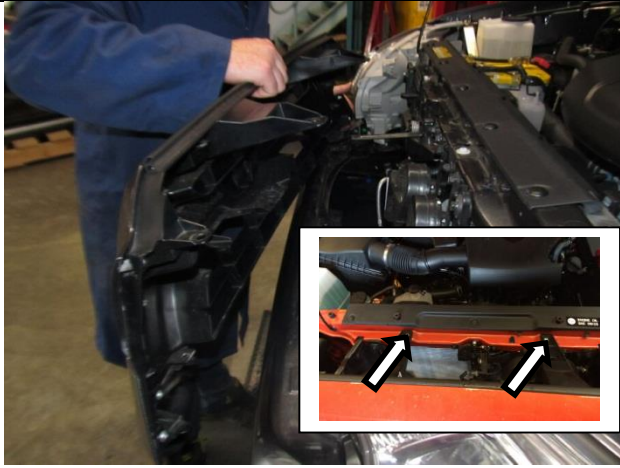

1. If fitted, remove licence plate from bumper and remove the top screws.



2. Remove grille from vehicle, you will need to remove top bolts, and the clips near the head light and then release lower grille tabs by pushing up, see below



3. Remove the bumper, by removing the clips along the top return and below the head light.
4. If there are fog lights fitted be sure to unclip the harness.



5. Remove the clips and screws along the bottom edge of the bumper.







6. Remove wheel arch bolts. Pull bumper ends out and away from vehicle to release them from clips. You will also need to unclip the wheel arch flare. Place on work stand front face up.

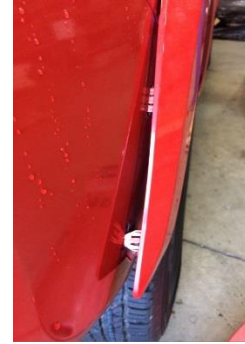

7. Remove the plastic bumper retainer. Note the top fastener is a bolt and the lower a plastic clip.



8. Remove the plastic from the crush beam and unclip the side brackets (from underneath).



9. Remove crush beam, retain nuts, set crush beam aside this will not be reused.

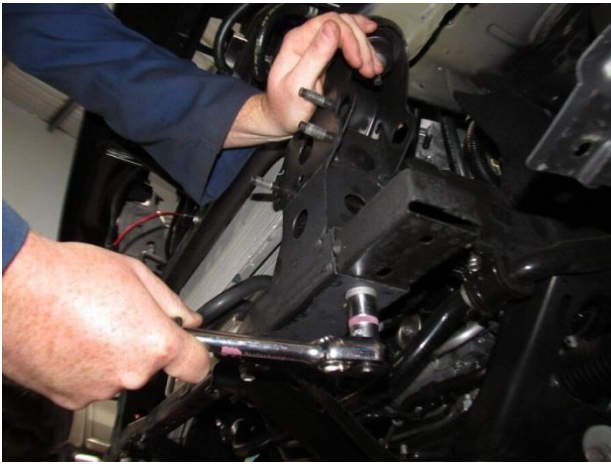

10. Remove lower bolts on cross member and remove cross member extensions both sides as shown, set aside these will not be reused



11. Remove plastic plugs in chassis holes in 4 places, inside and outside chassis in the area shown

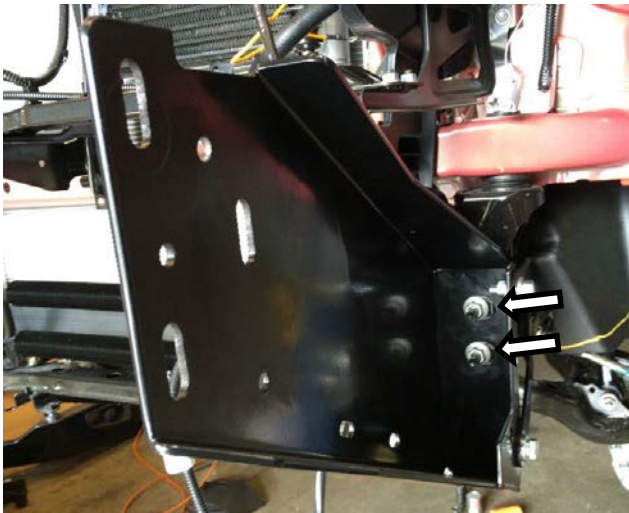

12. Fit bracket mounting assembly to front of vehicle using the 6 x M10 studs to locate on. Snug up only do not tighten.
13. Fit original M10 nuts to the fixing points. Snug up only do not tighten.

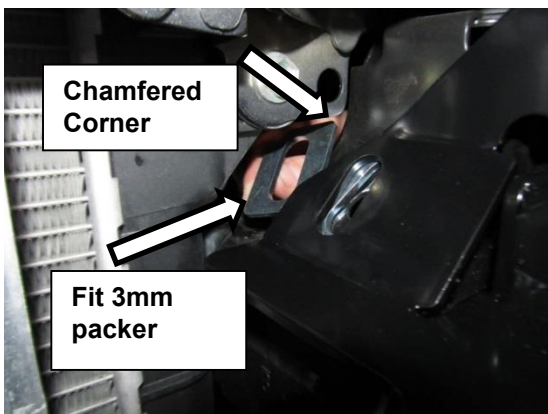

14. Fit 3mm packers as shown. Fit M12x1.25x35 bolts and M12 spring washer, flat washer and flange nut. Snug up only do not tighten.



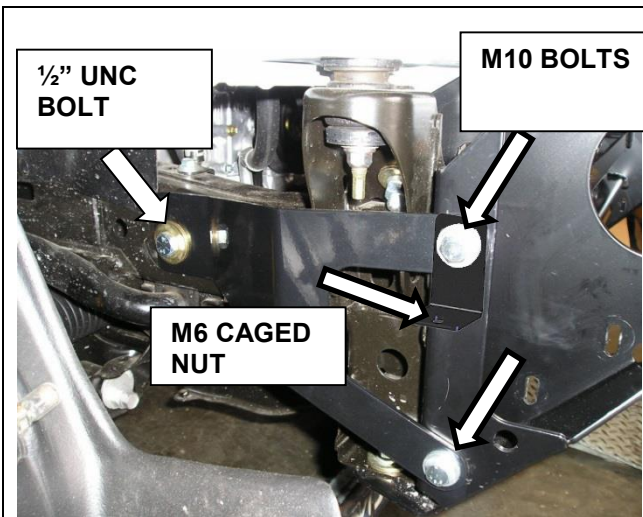

15. Fit tension brackets to each side of vehicle. The two front fixing bolts are M10 x 30mm, flat washers, spring washers and M10 nuts. Place the wing panel bracket under the flat washer of the top bolt as shown.

Fit M6 caged nut to top of the wing panel bracket.

The rear bolt is 4" x 1/2" UNC which is passed through the chassis from outside of vehicle and fitted with a large M12 washer and a 1/2" UNC Nyloc nut on the inside of vehicle.



16. Fit the M12 bolt spring, washer and flange nut to the bottom.

17. When all bolts are fitted, tighten front bolts

 M10 = 44 Nm.

 M12 = 77 Nm.

**Leave top M10 bolt loose enough to rotate wing panel bracket.**

Tighten rear 1/2" UNC bolt to a torque setting of  44 Nm.

**NOTE: These bolts may need to be loosened if bar adjustment is required at later point.**



18. If fog lamps are fitted to the bumper remove harness and set aside. You will re-use this.



19. Mark out the centre grill section. Place marking tape along the bottom edge and with non-permanent marker, mark a line 18mm from the bottom lip.



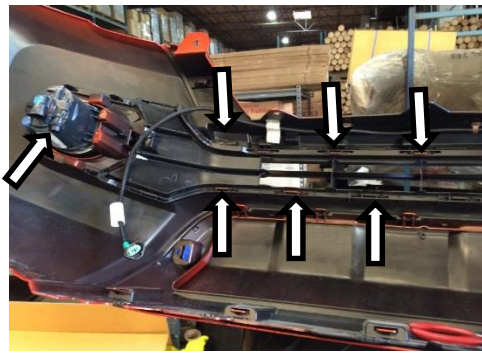

20. To make the bumper cut easier remove the fog lamp (if fitted) and the plastic grill insert in the bumper by depressing these tabs around the edge.



21. Cut the corners off as indicated in the picture.  
 22. Mask up the end and using the template provided with a non-permanent marker, mark a line as per the template.



Cutting line



23. Using a jig saw or multitool carefully cut the bumper ends (LH & RH) and the grille along marked lines.



**Cutting operations may result in flying debris, please wear protective goggles**

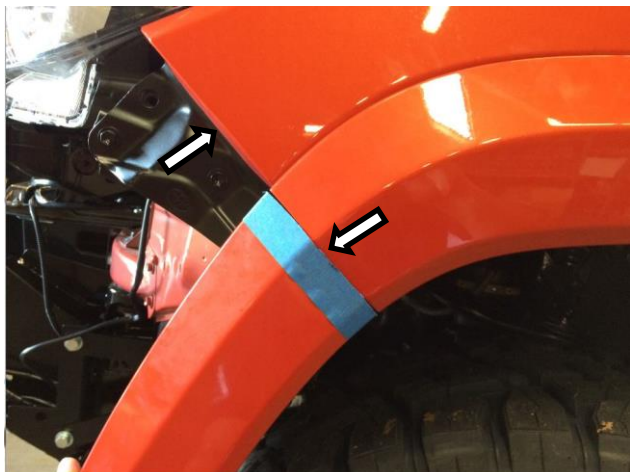

24. Mark the fender flare as shown. Use marking tape to protect the fender flare and using the fender edge as a guide, mark the fender flare. Repeat for other side.

25. Using a jig saw or multitool, carefully cut the fender flare ends (LH & RH) along marked lines.



**Cutting operations may result in flying debris, please wear protective goggles**



26. Using masking tape, mask up the bumper end and retaining bracket across the centre of the part.

(Bumper end fitted without retaining bracket shown in Picture)



27. Using the refitted cut bumper end as a guide mark the bumper retaining bracket.

(Post-cut retaining bracket without bumper end shown in Picture)

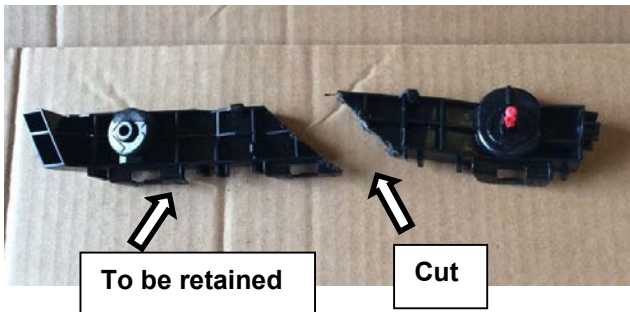

28. Using a jig saw or multitool, carefully cut the bumper retaining brackets along marked lines. Remove masking tape and deburr all edges with file or sandpaper.

29. Retain the top section and dispose of the lower cut off section. Repeat for other side.



**Cutting operations may result in flying debris, please wear protective goggles**



30. After removing the cut bumper end, remove masking tape and deburr all edges with file or sandpaper.

31. Fit the pinch weld to the bumper ends.



32. Carefully mask up the area around the bumper plastic trim mounting.



33. Using a Black spray can paint the panel. Allow to dry before removing tape. Repeat for other side.

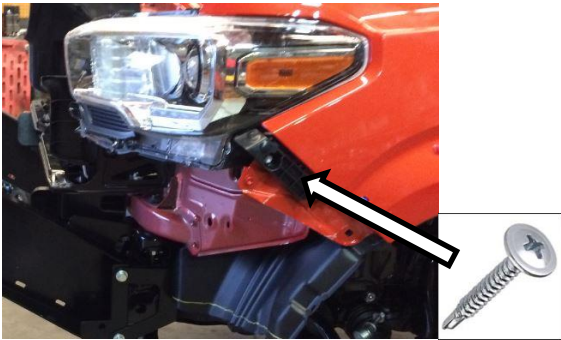

34. Re fit the cut bumper retainer. Only use the top bolt to hold the bracket in place.  
35. An additional Tek screw may be used to secure the bracket in place. Repeat for other side.

NOTE: Picture shows plastic retainer fitted prior to painting for clarity only.



36. Re-fit the grille and bumper ends to the vehicle.

NOTE: Use plastic protective film or a cover/blanket to ensure no damage to panels during bar fitment.



**Note: If fitting a winch proceed from here using fitting instructions 3789337 supplied with 3500720 winch install kit. Once the winch is fitted please continue to step 28. If no winch is being fitted continue from here.**

37. Slide the winch cover panel from the bottom up until it is level with the top face of the bar.
38. Fit the winch cover panel to the bar using 4 x M6 x 20 hex bolts, spring washers, flat washers and flange nuts.

**Warning: Be careful not to scratch the finish of the winch cover panel.**

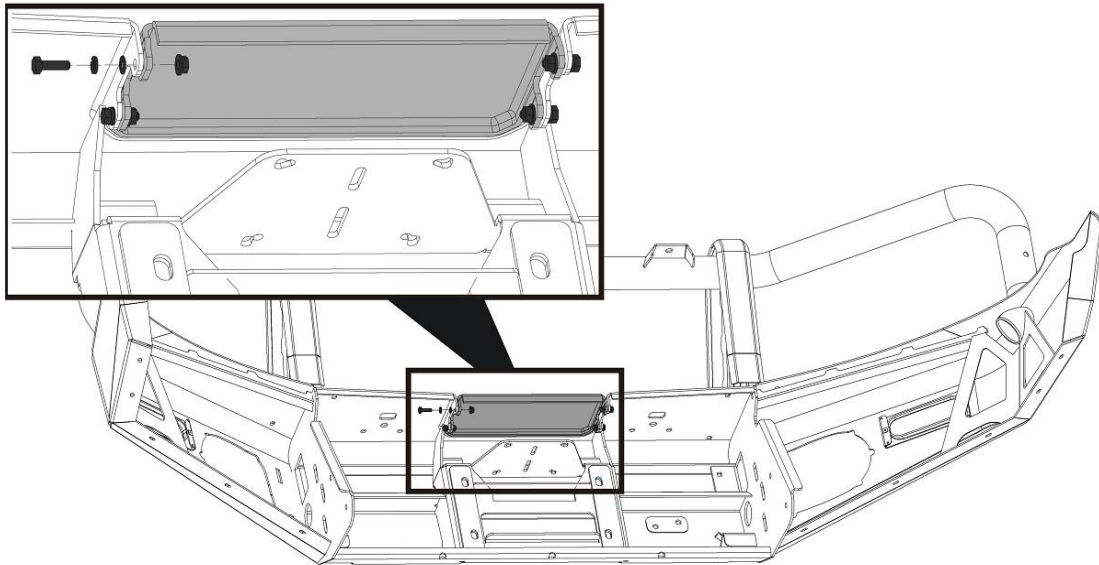

39. Fit the number plate bracket to the top face of the lower-centre pan on the bar using 3 x M6 x 20 hex bolts, spring washers, flat washers and flange nuts.

**Note: If you are fitting a winch, fit the folding number plate bracket supplied in winch install kit "3500720 WINCH INSTALL KIT LRG RAD BAR" – See fitting instructions 3789344**

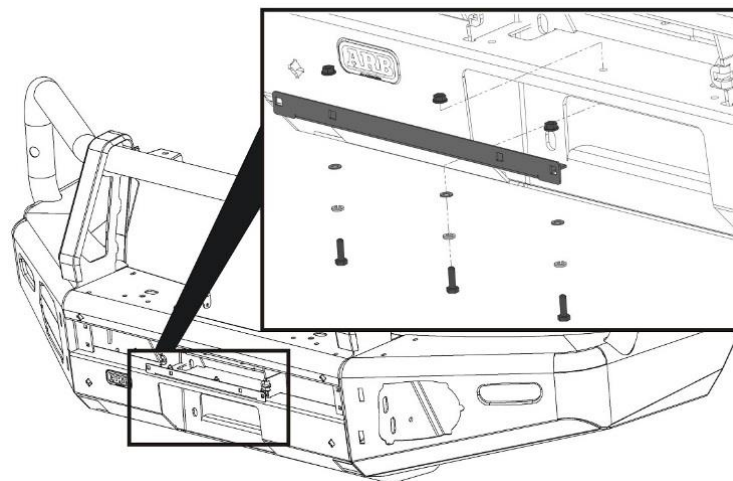

**Note: The following steps show the fitment of the plastic moulded parts. The mouldings are supplied in kits along with all fasteners required for fitment. It is important that the fasteners supplied with each kit are only used for the mouldings from the same kit. The kits included in this bar kit are:**



40. Layout the contents of each of the following kits ensuring the contents are kept separate from each other.

Kit No.	Description
5100200	BUFF KIT 2PCE FRONT SECTION
5100210	BUFF KIT 2PCE REAR UPRIGHT BAR
3500710	SPLIT PAN MESH GRILL LRG RAD
3163082	FOG SURROUND KIT

41. Mark the grille panel to be cut at the 810mm marks at each end on the back face.

**Note: When marked, double check the measurement with a measuring tool.**

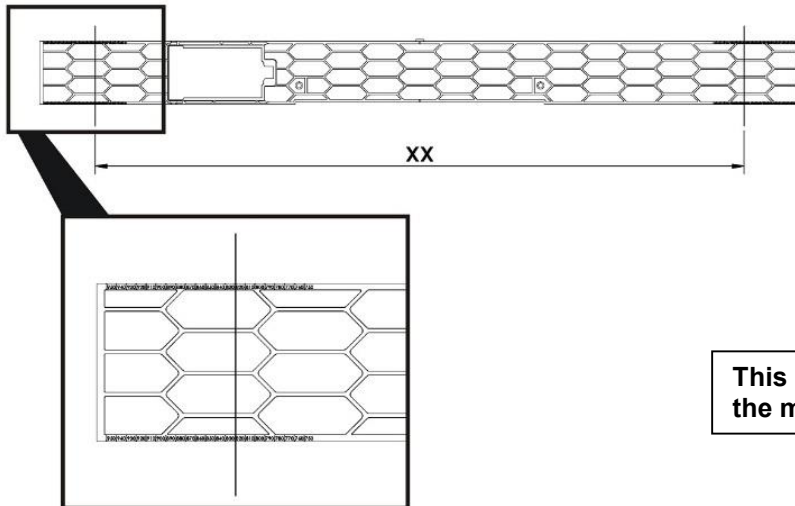

**This picture is for reference only. Use the measurement shown above.**

42. Use a hacksaw or similar cutting tool to carefully cut the grille panel at the positions marked in the step above.
43. Discard the off cuts and clean up the cut edges using a file or sandpaper.

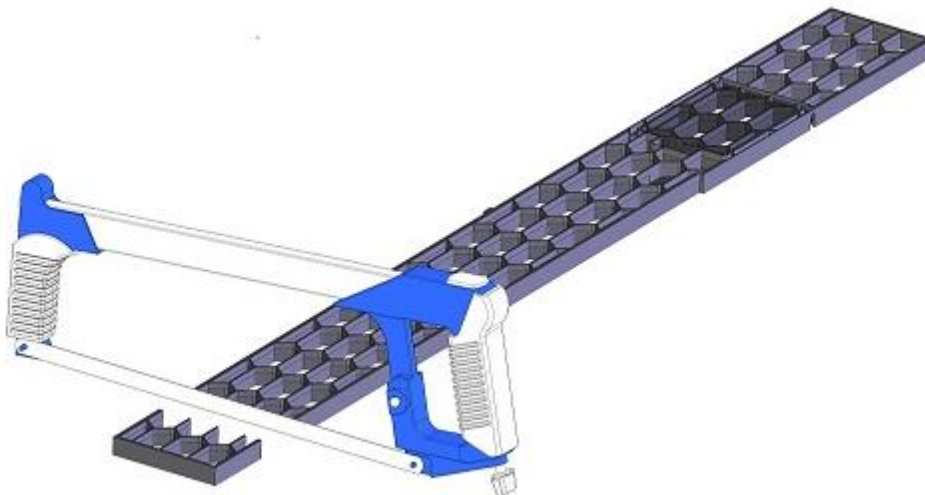

44. Insert the 6 x plastic grommets into the 6 square holes in the front face of the bar.
45. Insert the grille into the bar so that the hatch is on your right hand side (facing the front of the bar).
46. Attach the grille to the centre of the bar using the short screws into the grommets fitted above.
47. Attach the ends of the grille to the bar using the longer screws, through the clamp plates into the remaining grommets.

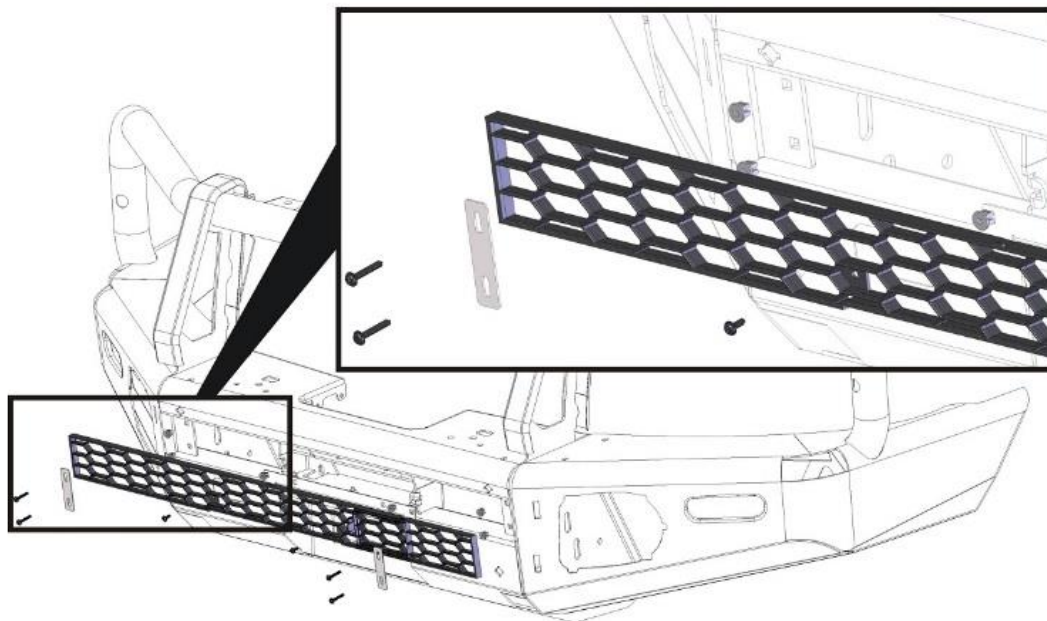

48. Fit the rubber intersection mouldings to the base of each upright cover strap.

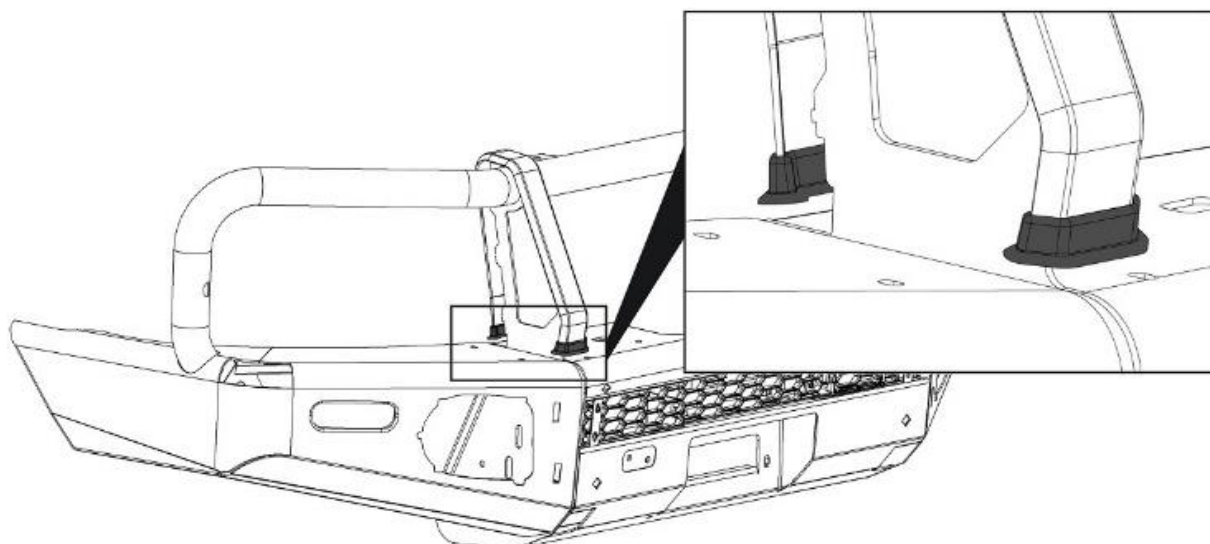

49. Place each of the front buffer sections onto the bar as shown. Ensure that the 2 lugs and 2 screw bosses pass through the holes in the bar and that the buffer sits flat against all surfaces,

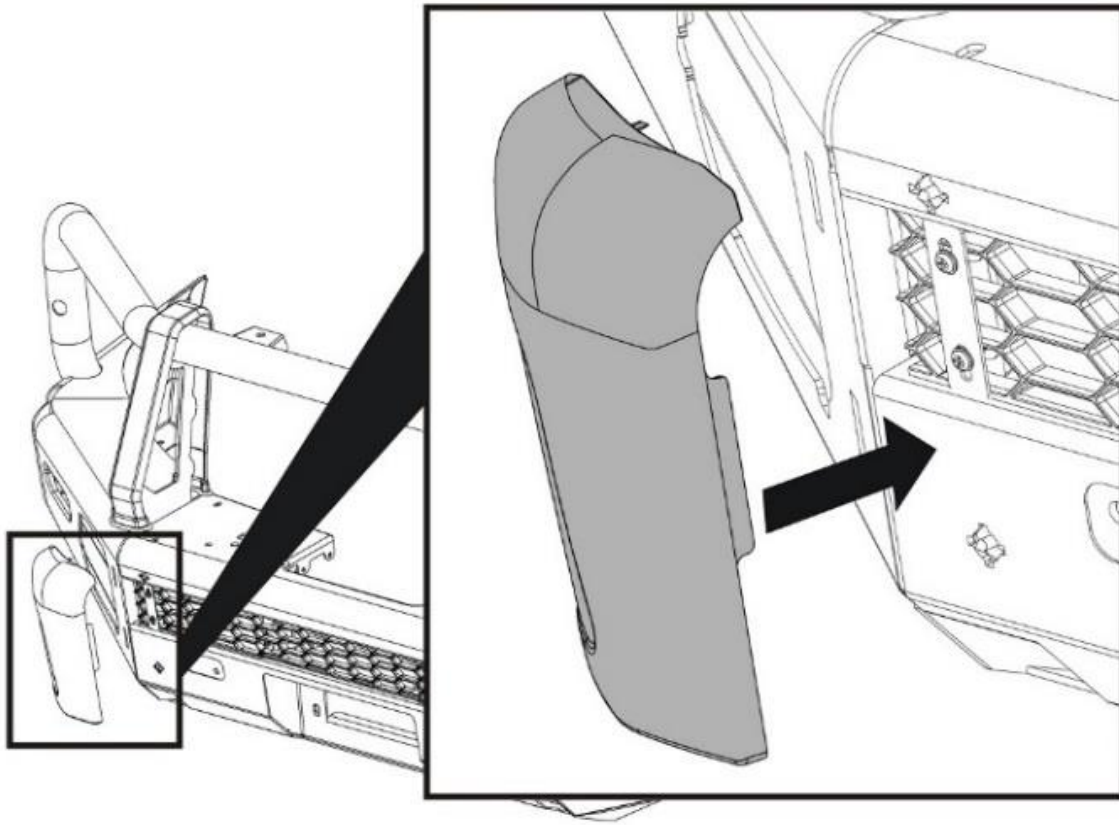

50. Attach the buffers to the front centre face of the bar using the angled cup washers and the screws provided.

**Note:** *The widest point of the cup washers goes to the top of the bar.*

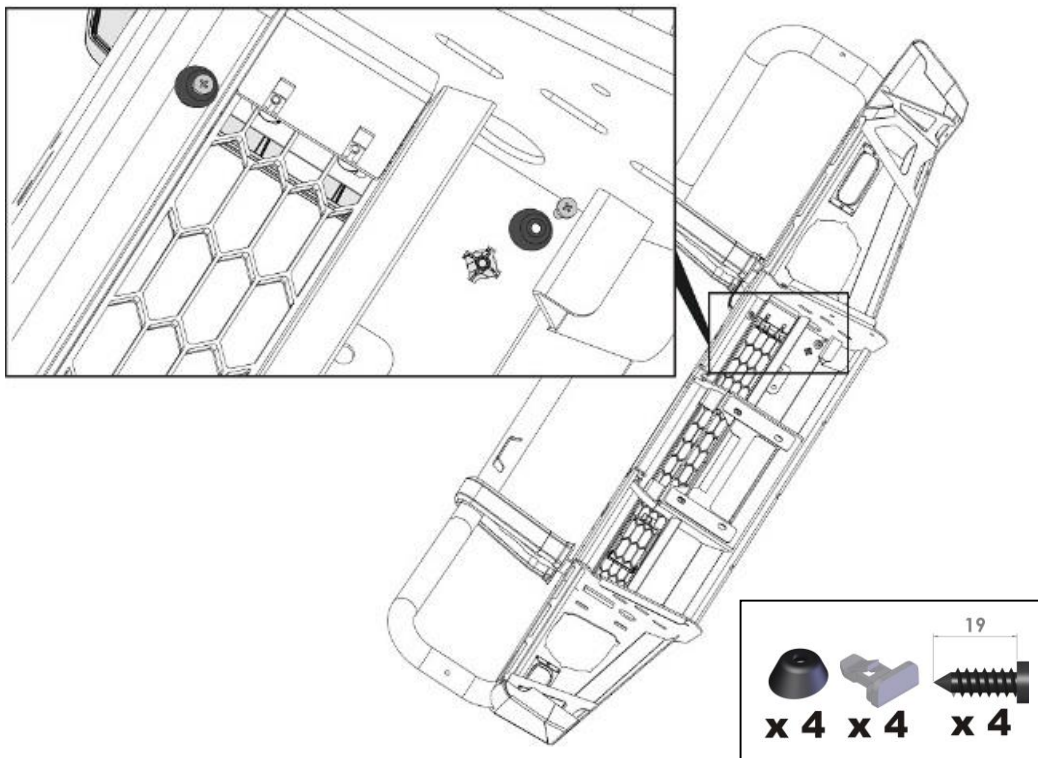

51. Attach the buffers to the front faces of the wings using the plastic clip provided.

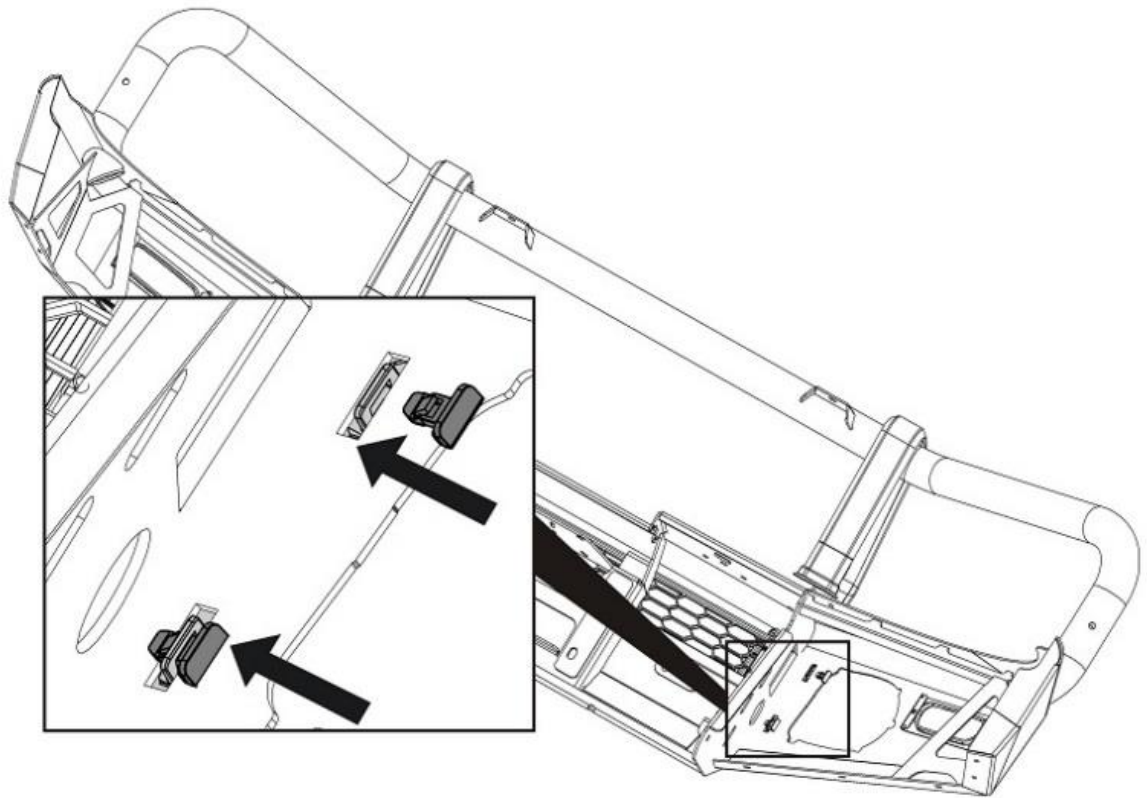

52. From the rear of the bar slide the rear buffer sections into the front sections as shown. Ensure the tongue section on both sides of each buffer engages into the slots of the front sections.

**Note:** Ensure that the skirts of the rubber intersection mouldings are not folded back on themselves and are sitting flat against the buffers.

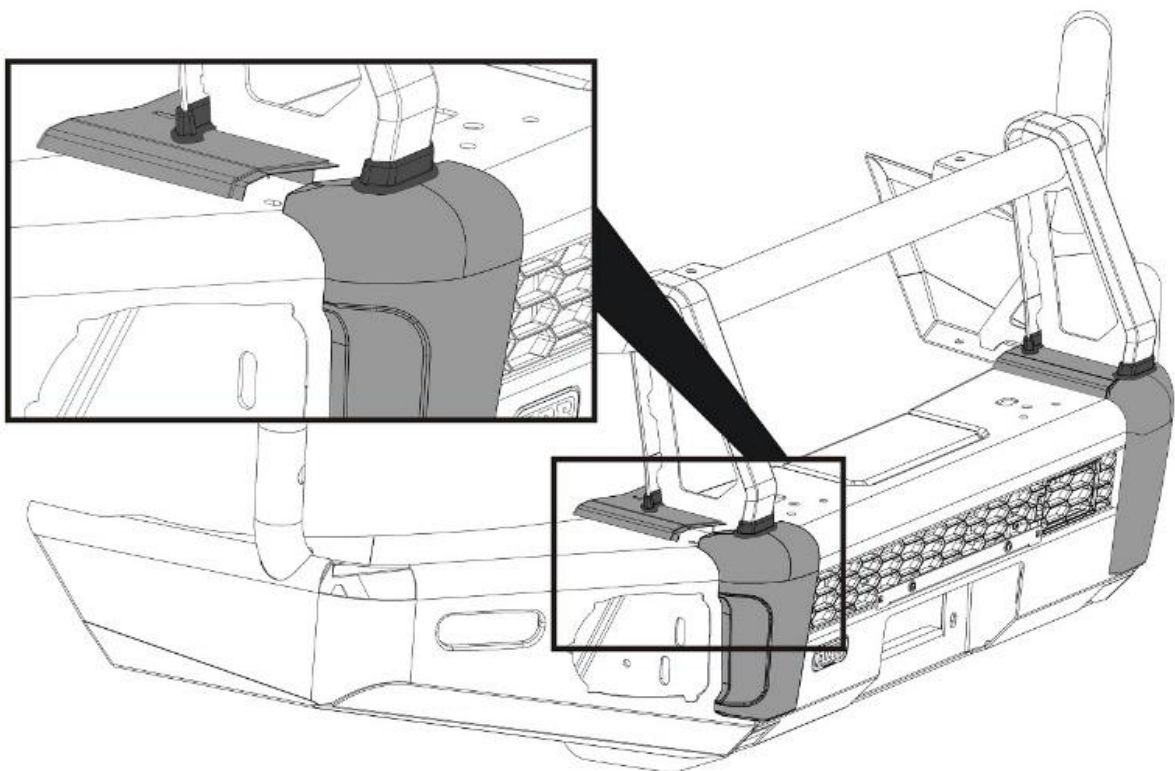



53. Attach the rear buffer sections to the bar using the supplied screws.

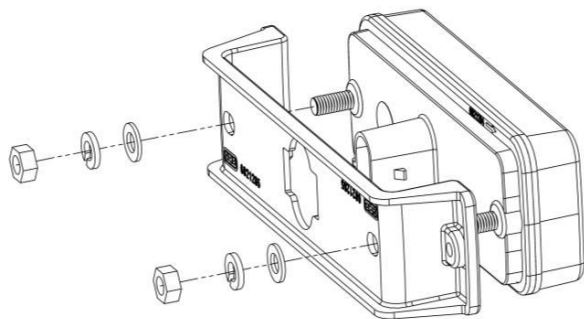
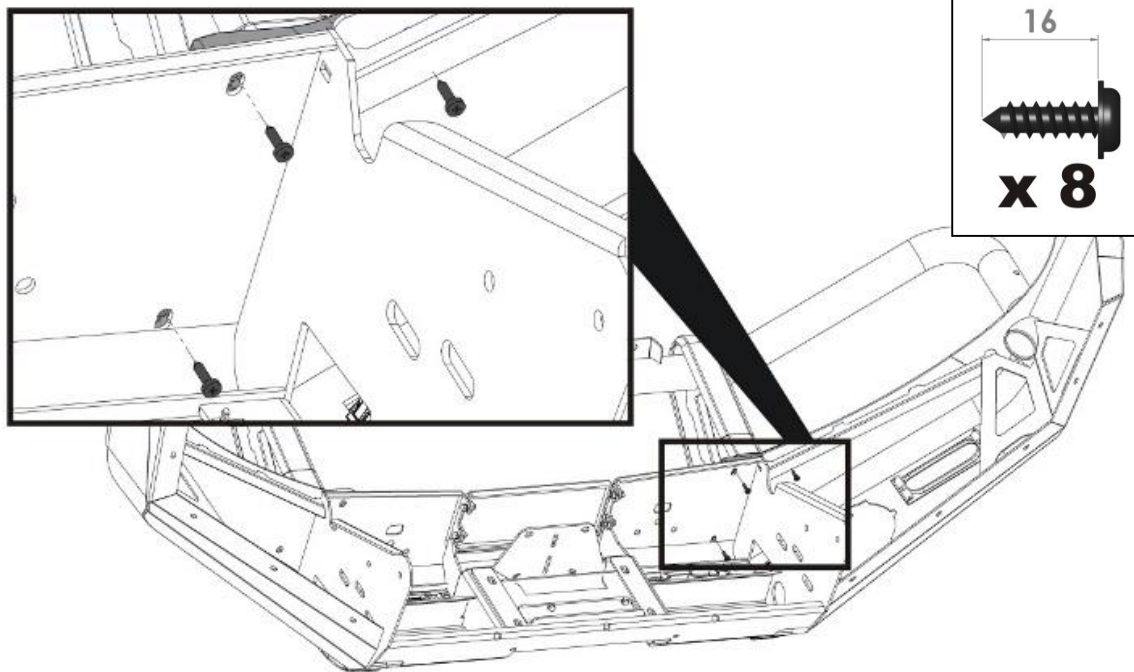

54. Install 6821285 bracket onto LED lamp with 2 x flat washer, 2 x spring washer and 2 x M6 nuts as shown. **Note: Bracket and fasteners are supplied in 6821287 – LED Indicator/Clearance Kit.**

Torque to specification.

 M6 - 3 Nm.

**NOTE: Do not over-tighten.**

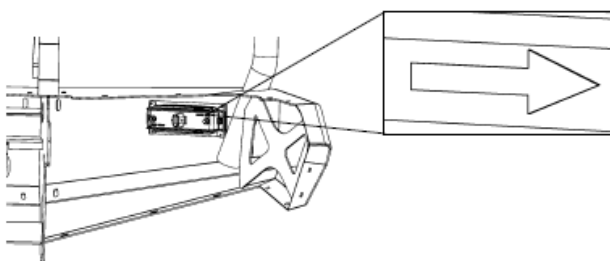

55. Fit the small plastic grommets to the bar. Install LED lamp with bracket into bull-bar using 2 x 15mm mounting screws provided in 6821287 – LED Indicator/Clearance Kit. (RH Shown).

**Note: Do not fully tighten.**

**IMPORTANT:** The clearance LEDs must be on the outboard edge of the bull-bar. To achieve this, position lamp with arrows facing outside of vehicle as shown below.

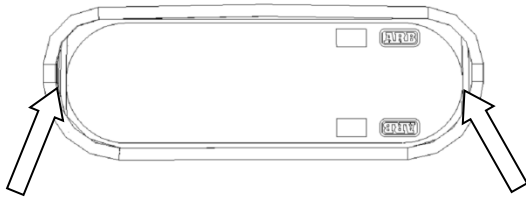

**ADJUST GAPS TO BE THE SAME**

56. Viewing the installed LED Lamps from the front of the bull bar – adjust the Lamp positions so that they are central in the formed apertures and any gap on either side is the same.

Once adjusted fully tighten the 15mm mounting screws.



57. With the help of a friend, lift bull bar on to chassis mount bracket and align slots in mount.

**Warning: Due to the weight of the bar and winch if fitted, it is advised that you use some form of mechanical assistance when lifting the bar onto the vehicle such as an elevating trolley.**

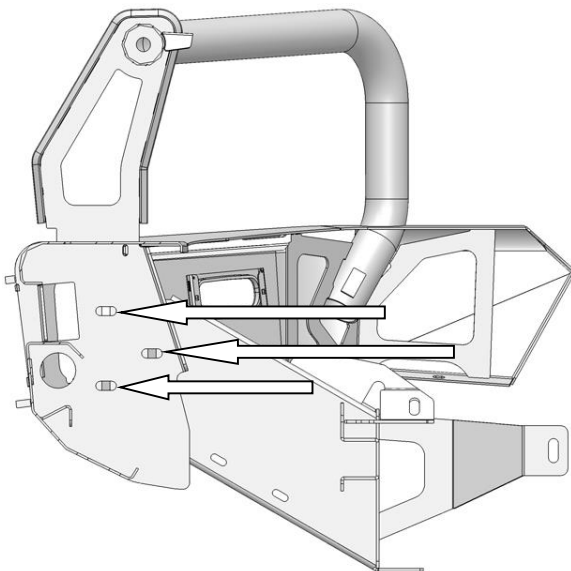

58. Loosely fasten bar to mounts using 6x M12x1.75x35mm bolts, 6x M12 spring washers, 6x M12 flat washers (4mm thick) and 6X M12 flange nuts.

**ARROWS INDICATE WHICH HOLES TO USE IN SECTION VIEW DRAWING.**

**SECTION VIEW IS RHS OF VEHICLE.**

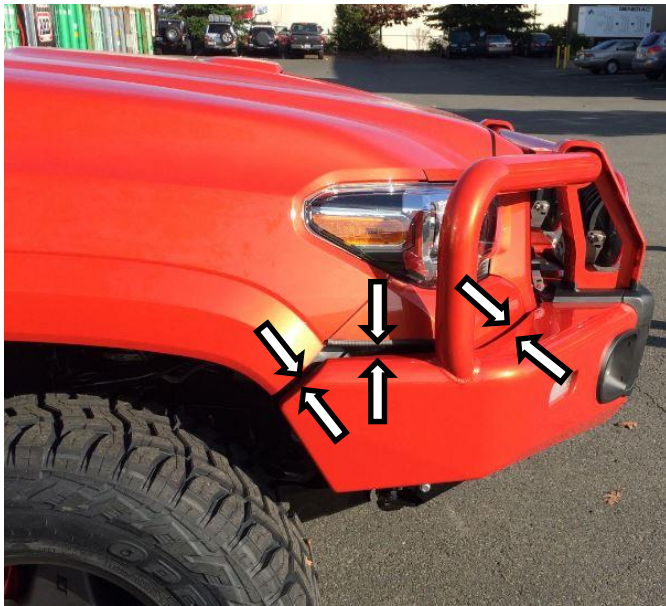

59. Align bull bar so there is a 15mm to 18mm gap from top of wings to underside of flares and an even 10mm minimum gap to vehicle including periphery under front vehicle panels, and then tighten all bolts.
60. If the bull bar is not central on the vehicle loosen the mount bolts to the chassis (step 14), remove the 3mm packers and adjust bull bar position, add packers as appropriate and retighten all fasteners as specified.

 M12 = 77 Nm.

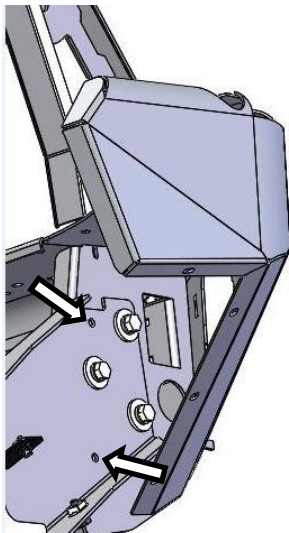

61. Once happy with the position of the bar and all fasteners are correctly torqued, using the existing 2 holes in the mount as a guide, drill through using a 10mm drill bit and secure using two M10 SEMS and M10 flange nuts, tighten to

 M10 = 44 Nm.

**NOTE: These bolts are to lock the bull bar to the chassis mounting bracket**



**Warning: Drilling operations can result in flying metal debris, safety glasses should be worn.**



62. Assemble and install combination light surrounds (p/n 3163082) as per instructions no. 3789190 supplied with surround kit. Note: Optional fog lamps can be installed at this point as per fitting instruction supplied with fog lamp kit no. 6821201.



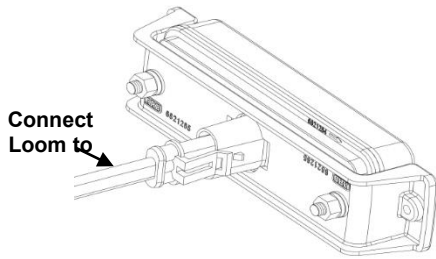

63. Connect LED Indicator/Clearance Light and Fog Lamp wiring looms/plugs. Connect RH & LH plugs (6821286) to LED lamp as shown. (RH clearance shown).

**Caution: Cable tie all cables together and keep all cables clear of sharp edges and moving parts.**

**M8 CAGED NUTS**

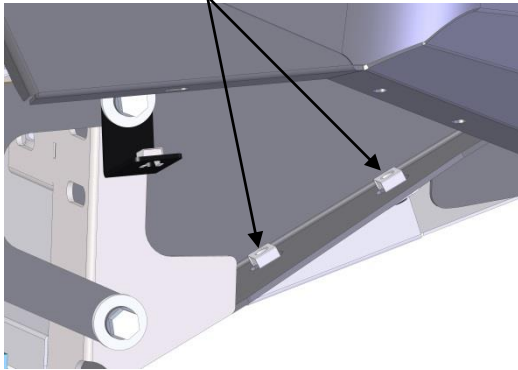

64. Fit M8 caged nuts to the inside of the mounting arm, RH & LH side. (RH side shown)

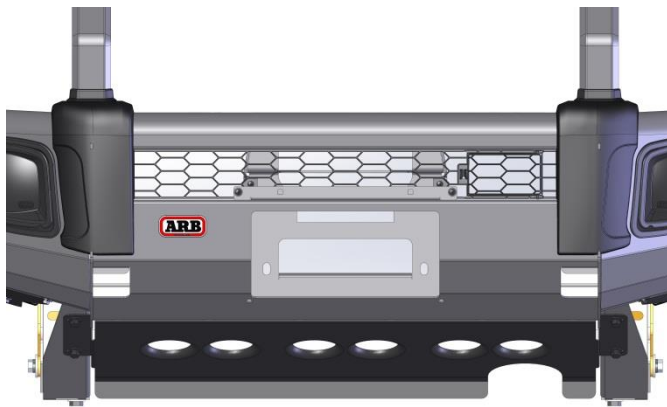

65. Fit splash pan between bull bar mounts in the orientation as shown.

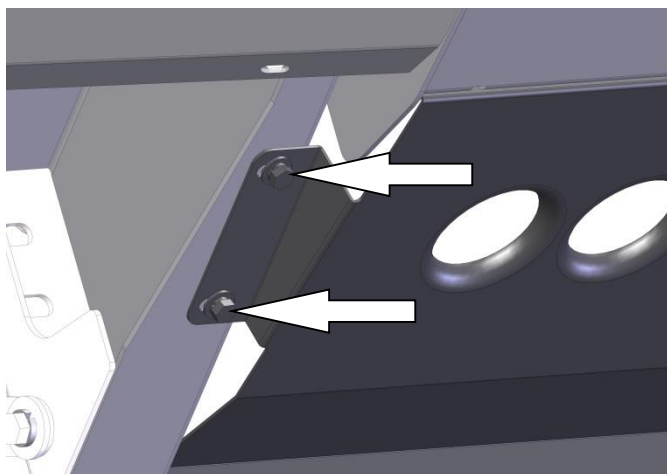

66. Fit side bolts for splash pan to bull bar mount sides using M8 x 25mm bolts, spring washers and large flat washers. Snug up only.

67. When all bolts are fitted, tighten

 M8 = 22 Nm.

**ARROWS INDICATE M8 BOLT POSITIONS**



**M6 CAGED NUTS**

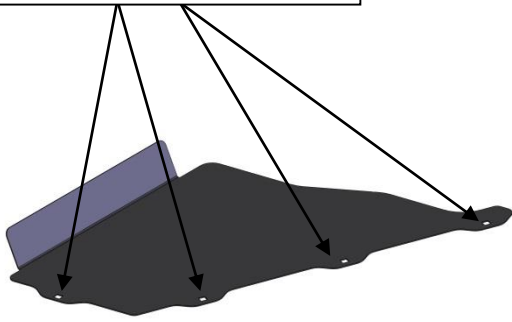

68. Fit M6 caged nuts to the inside of the flanges on the splash pan, RH & LH. RH side shown.

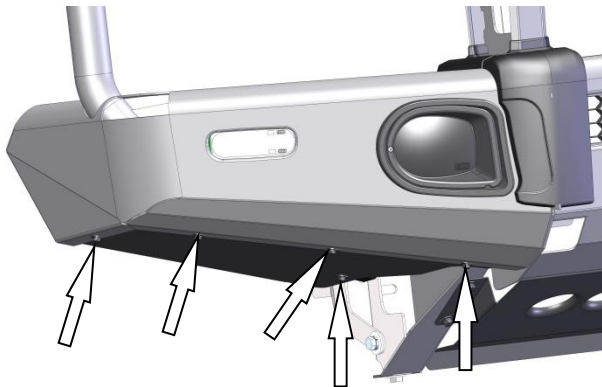

69. Place splash pan on inside lip of side wing. RH side shown. LH is opposite.
70. Fit under bolts for splash pan to bull bar wing using M6 x 20mm bolts, spring washers and large flat washers. Snug up only.
71. When all bolts are fitted, tighten to specified torque.

 M6 = 9 Nm.



72. Once under wing panel is fitted mark a line approx. 15mm above the under wing panel. Cut the wheel well liner and tuck behind the rear lip of the wing under panel. Repeat for other side.



73. Driving lights can be fitted at this stage.

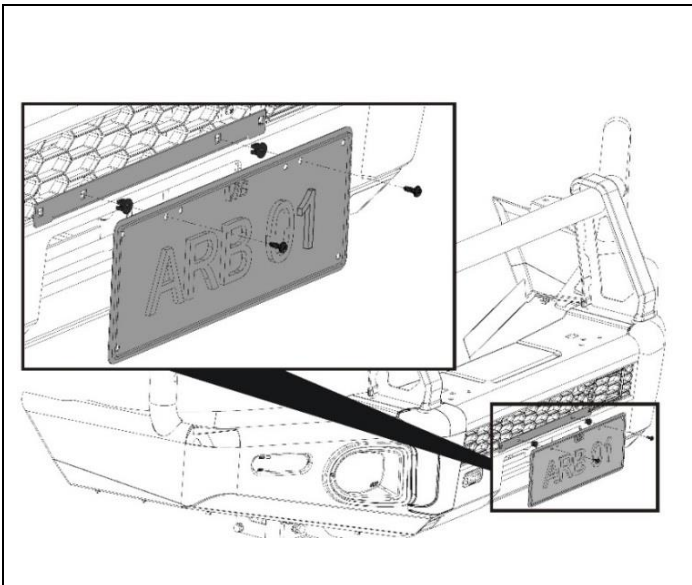

74. If fitting licence plate, fit the plastic grommets into the square holes in the licence plate bracket. Fit the licence plate to the bull bar using the black self-tapping screws.

### **ONCE BAR IS FITTED:**

- ◆ **Ensure all bolts are tensioned correctly.**
- ◆ **All wiring is clear of sharp edges or moving surfaces and secured properly.**
- ◆ **Piping is secured well away from sharp or moving components**
- ◆ **Check operation of winch if fitted.**
- ◆ **Check all wiring and connections to turn signal lamps, sensors, headlamp washers etc. are functioning correctly.**

### **FITTED PRODUCT**

