

ENFORCER II®



U - Universal Muffler, Sorted first by cross section, then shell length, then inlet diameter.

U - Silenciador Universal, Sorteado primero por seccion cruzada, despues largo de el cuerpo, despues diametro de la entrada.

6" Round / Redondo

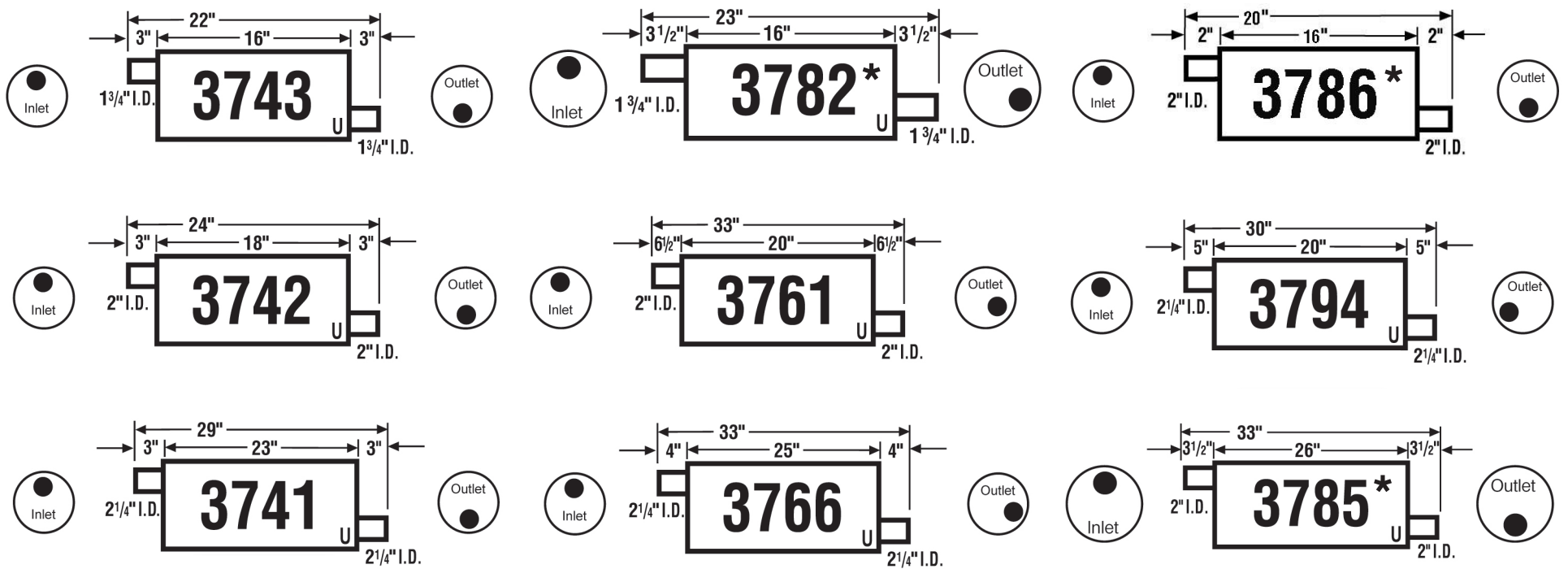

3 1/4" x 7 3/4" Oval / Ovalado

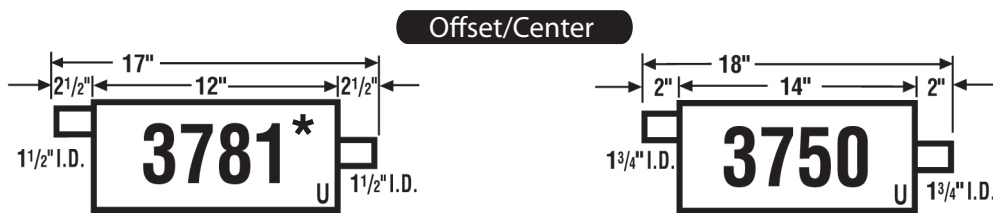

4 1/4" x 8 3/4" Oval / Ovalado

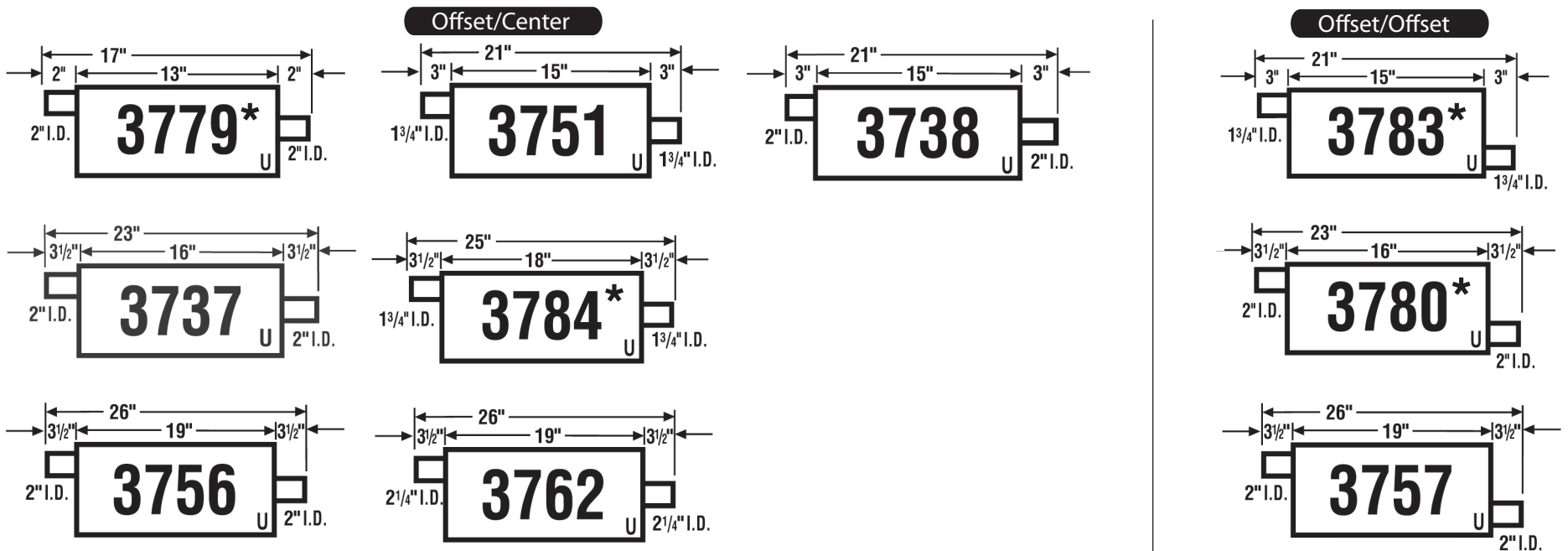

4 1/16" x 10 1/2" Oval / Ovalado

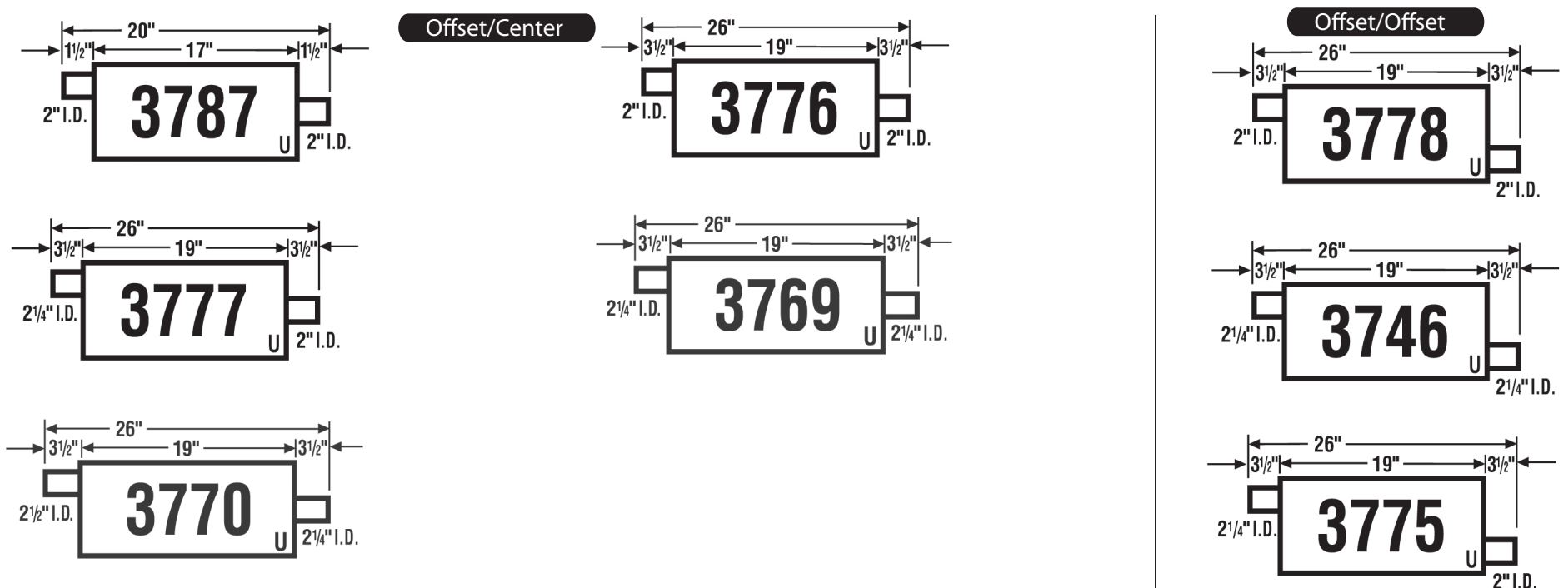

Learn more about exhaust systems on our website.