

ALL AMERICAN BILLET

PROUDLY MADE
IN THE U.S.A.



CATALOG 21



INDEX

CLASSIC BILLET PARTS MADE IN THE USA.



Front Drive Systems	4-37	Interior Accessories	44-55
Chevy Big Block	20-21	Ash Tray Handles	47
Chevy Big Block, Supercharger	36	Column Drops	54-55
Chevy Small Block	5-7	Cup Holders	50
Chevy S-Block Serpentine Conv Kit	37	Dimmer Switch Covers	46
Chevy LS1, 2, 3, 6 & 7	8-9	Door Lock Knobs	51
Chevy LS No AC & with PS	10-11	Door Pullstrap Covers	46
Chevy LSA	14-15	Door/Window Crank Handles	44-45
Chevy LS(x)	12-13	Gauge Holders	53
Chevy LT4	16-17	Shift Knobs & Handles	48-49
Chevy LS Vortech Supercharger	18-19	Steering Wheels	52
Chrysler/Hemi Big Block	32-33	Visor Clips	47
Chrysler Small Block	30-31		
Ford 351 Cleveland	28-29	Exterior Accessories	59-63
Ford Big Block	26-27	Door Jamb Vents	59
Ford FE	24-25	Door Props	61
Ford Small Block	22-23	Emblem Sets	62
Hemi 5.7 & 6.1	34-35	Gas Doors	61
		Sider Marker Bezels	59
Engine Accessories	38-43	Tail Light Bezels	59
Air Compressors	38	Tail Gate Latches	60
Air Cleaner Nuts	40	Washers & Washer Kits	63
Alternators	38	Windshield Wiper Post Covers	60
AC/Heater Bulkheads	40		
Fuel Block Offs	43	Suspensions	64-66
Hose Kits	38-39	Crossmember, 63-87 C-10	66
Oil Breathers	42	Crossmember, 63-72 GM	
Power Steering	39-40	Carrier Bearing, Adjustable, Bolt-On	65
Radiator Overflow Tanks	40	Front Suspension, Chevy 63-72 C10	64
Spark Plug Wire Looms	43	Front Suspension, 67-72 F-100	66
Spark Plug Wire Separators	43	Rear, 67-72 Chevy, Air Bag Kit Bolt-On	65
Valve Cover Conv Kit LS-SB Chevy	42	Trailing Arms, Rear 60-72, Chevy C-10	64
Water Pumps	38	Watts Link Kit, 63-72 GM Bolt-On	65
Ford Bronco Parts	56-58	Hood Hinges	67-69
Door Cups, Interior	58	55-80 Chevy Hood Hinges	67-69
Door Handles, Exterior	58	Lowered Hood Hinges	68
Door Panels	56-57		
Door Panels, Rear Interior	56	Miscellaneous	70-71
Handles, Universal	57	Website info	70
Steering Column Bezels	57	Terms & Conditions	71
Tailgate Latches	58		

NEW PRODUCTS

FORD BRONCO PARTS + ACCESSORIES

PG 56-58



BILLET EMBLEMS

PG 62



POWER STEERING BRACKETS

PG 40



SMALL BLOCK CHEVY SERPENTINE CONVERSION KIT

PG 37

Our serpentine conversion kits are a great way to upgrade your front drive accessories and clean up your engine.

Our kits convert V-belt pullies to the modern 6-rib serpentine belts and mount through the water pump for easy installation/adjustment. version features a short water pump, air conditioning and uses a type II power steering pump.

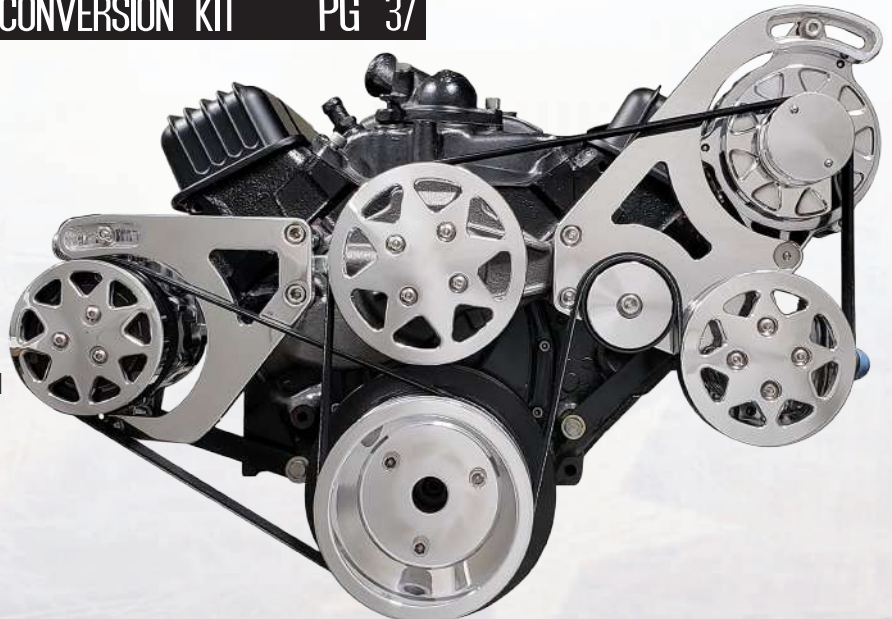

SERPENTINE KITS

POWER STEERING KITS INCLUDE RESERVOIR, BRACKET AND HARDWARE

All American Billet Serpentine Kits are a great way to clean up any engine compartment. Our kits come standard with High Quality Accessories and are made in the U.S.A. Brackets are made from 6061-T6 aluminum, and come in Machine Finish, Polished and "Silverline" Series.

MADE IN THE
U.S.A.



REMOTE RESERVOIR

For kit with Remote Reservoir
(Remote Reservoir is standard)
Example: [FDS-SBC-101](#)



ON-BOARD RESERVOIR

For kit with an On-Board Reservoir
substitute (5) in item number for (0)
Example: [FDS-SBC-151](#)



ALL AMERICAN BILLET

KITS INCLUDE

*(See individual listings as some kits may have additional parts
Timing Cover, Idler Pulleys, Harmonic Damper etc...)*

- REVERSE ROTATION WATER PUMP
- 6061-T6 ALUMINUM PULLEYS
- GATES SERPENTINE BELT
- STAINLESS STEEL HARDWARE
- TENSIONER WITH COVER
- POWER STEERING RESERVOIR (REMOTE OR ON-BOARD)
- LEFT OFFSET CS130 - 160 AMP, 1 WIRE ALTERNATOR
- PEANUT STYLE A/C COMPRESSOR (IF A/C KIT) (SANDEN SD7B10 STYLE)
- TYPE II POWER STEERING PUMP (1200 PSI, 3GPM RATING) (IF PS KIT)

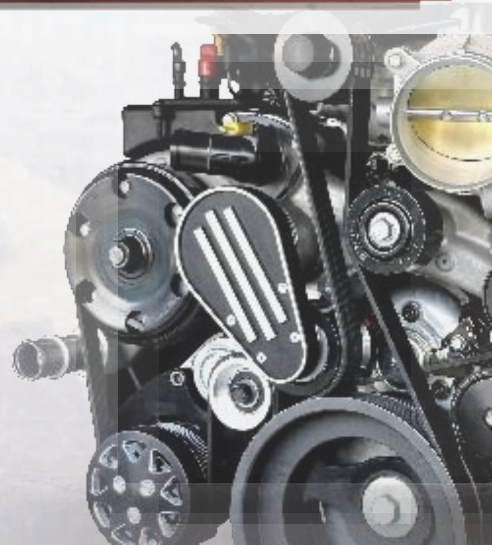

POLISHED SMALL BLOCK CHEVY

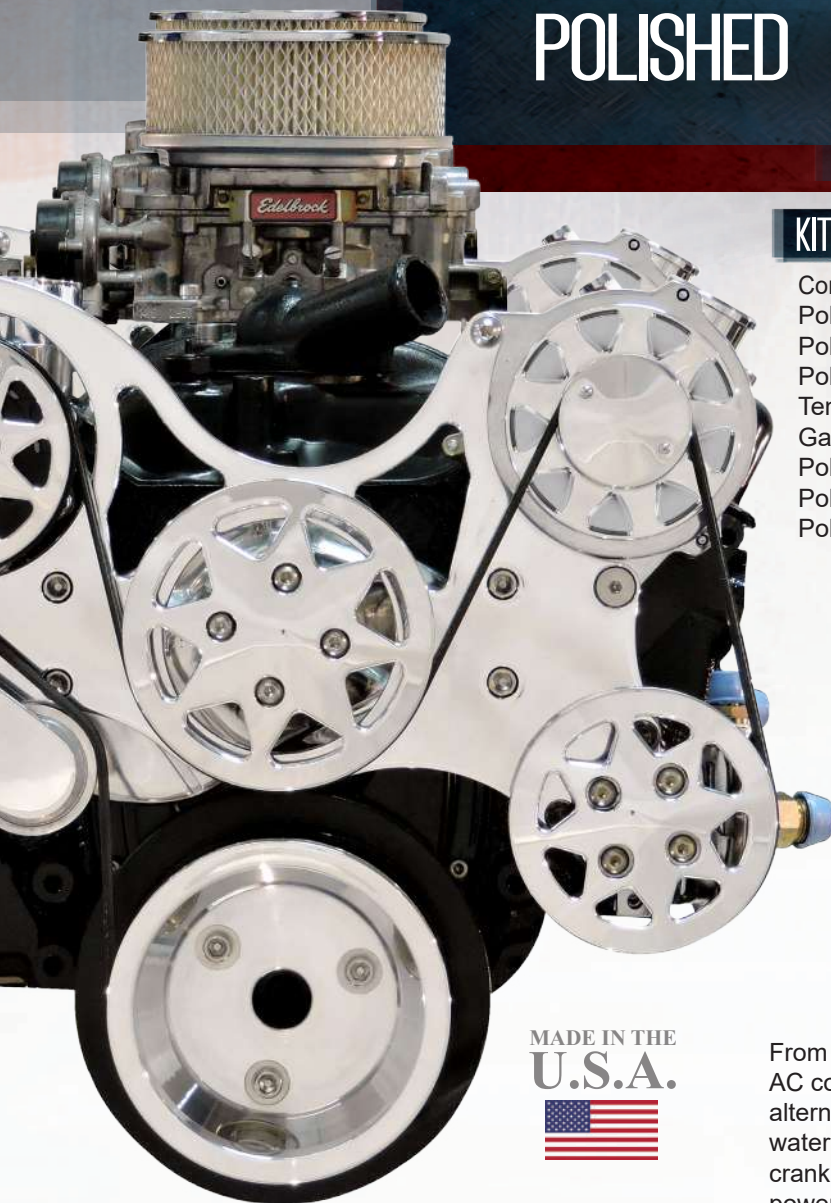

KIT INCLUDES

- Corvette Style Short Water Pump as cast
- Polished 160 Amp, 1 wire alternator
- Polished 6061-T6 Aluminum Pulleys
- Polished 6061-T6 Brackets
- Tensioner with Polished Aluminum Cover
- Gates 6-Groove Belt & Stainless Steel Hardware
- Polished Peanut Style A/C Compressor (if A/C kit)
- Polished Power Steering Reservoir (if PS kit)
- Polished aluminum Type II Power Steering Pump (if PS Kit)

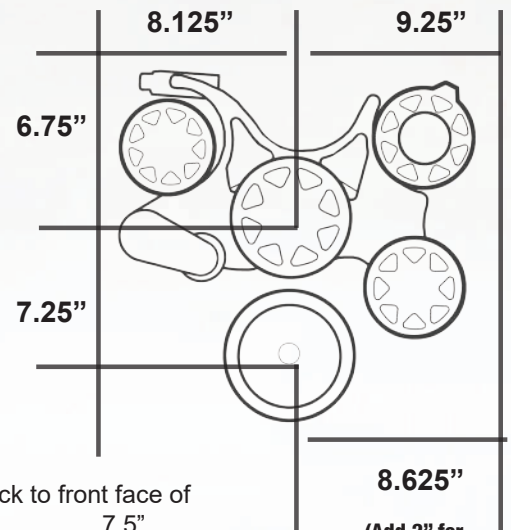

MADE IN THE
U.S.A.



- From front of block to front face of
- AC cover: 7.5"
 - alternator pulley: 6.625"
 - water pump pulley: 6.5"
 - crank pulley: 6.25"
 - power steering pulley: 6.5"

8.625"

(Add 2" for
On Board Res)



**Polished - With A/C
With Power Steering**
FDS-SBC-101

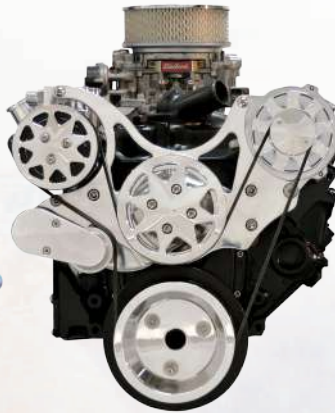

**Polished - With A/C
No Power Steering**
FDS-SBC-102

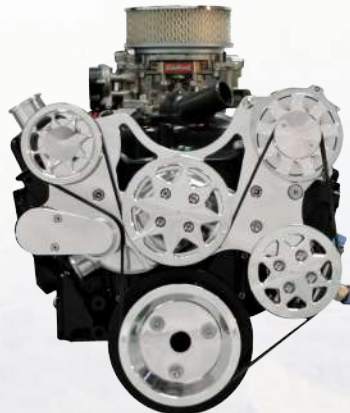

**Polished - No A/C
With Power Steering**
FDS-SBC-103



**Polished - No A/C
No Power Steering**
FDS-SBC-104

FITMENT NOTES:

*Requires factory timing cover for short water pump
85-91 Corvette factory application on water pump*

SILVERLINE SERIES SMALL BLOCK CHEVY

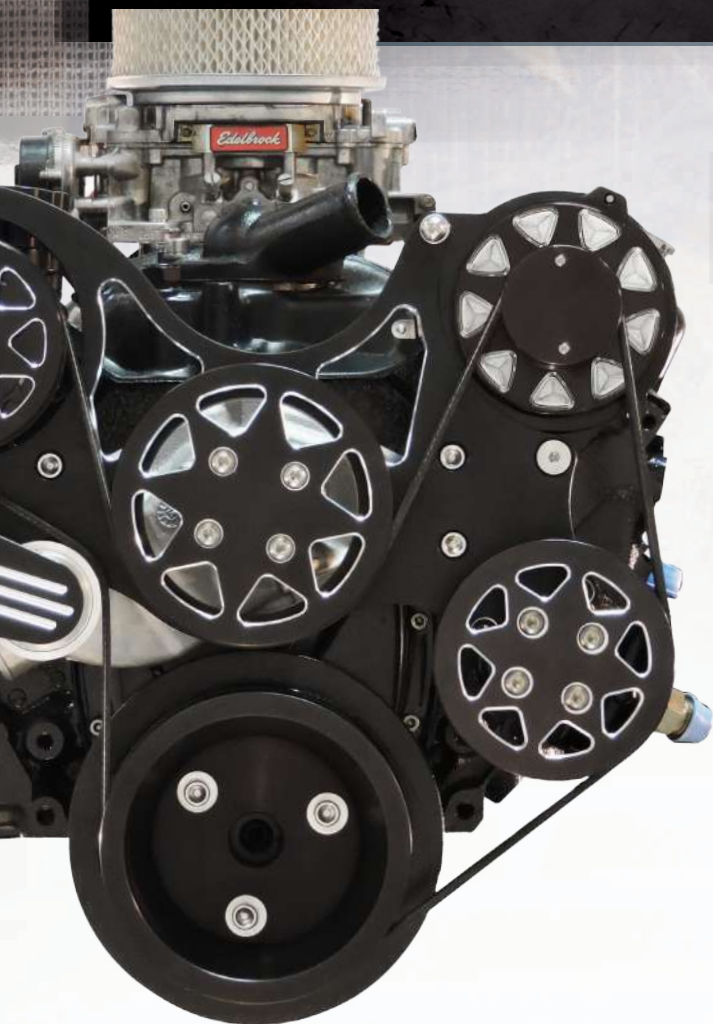

SILVERLINE SERIES KITS WERE DESIGNED TO GIVE ANY ENGINE THAT AGGRESSIVE BLACK STYLE HIGHLIGHTED BY MACHINED FINISHED AREAS FOR A TRULY STANDOUT LOOK

KIT INCLUDES

Black 160 Amp, 1 wire alternator
6061-T6 Silverline Series Brackets
Corvette Style Short Water Pump As Cast
6061-T6 Silverline Series Aluminum Pulleys
Gates 6-Groove Belt & Stainless Steel Hardware
Black Peanut Style A/C Compressor (if A/C kit)
Black Aluminum Type II Power Steering Pump (if PS Kit)
Silverline Series Power Steering Reservoir (if PS kit)
Tensioner with Silverline Series Aluminum Cover

MADE IN THE
U.S.A.



Silverline Series - With A/C
With Power Steering
FDS-SBC-201



Silverline Series - With A/C
No Power Steering
FDS-SBC-202



Silverline Series - No A/C
With Power Steering
FDS-SBC-203



Silverline Series - No A/C
No Power Steering
FDS-SBC-204

FITMENT NOTES:

*Requires factory timing cover for short water pump
85-91 Corvette factory application on water pump*

MACHINED SMALL BLOCK CHEVY

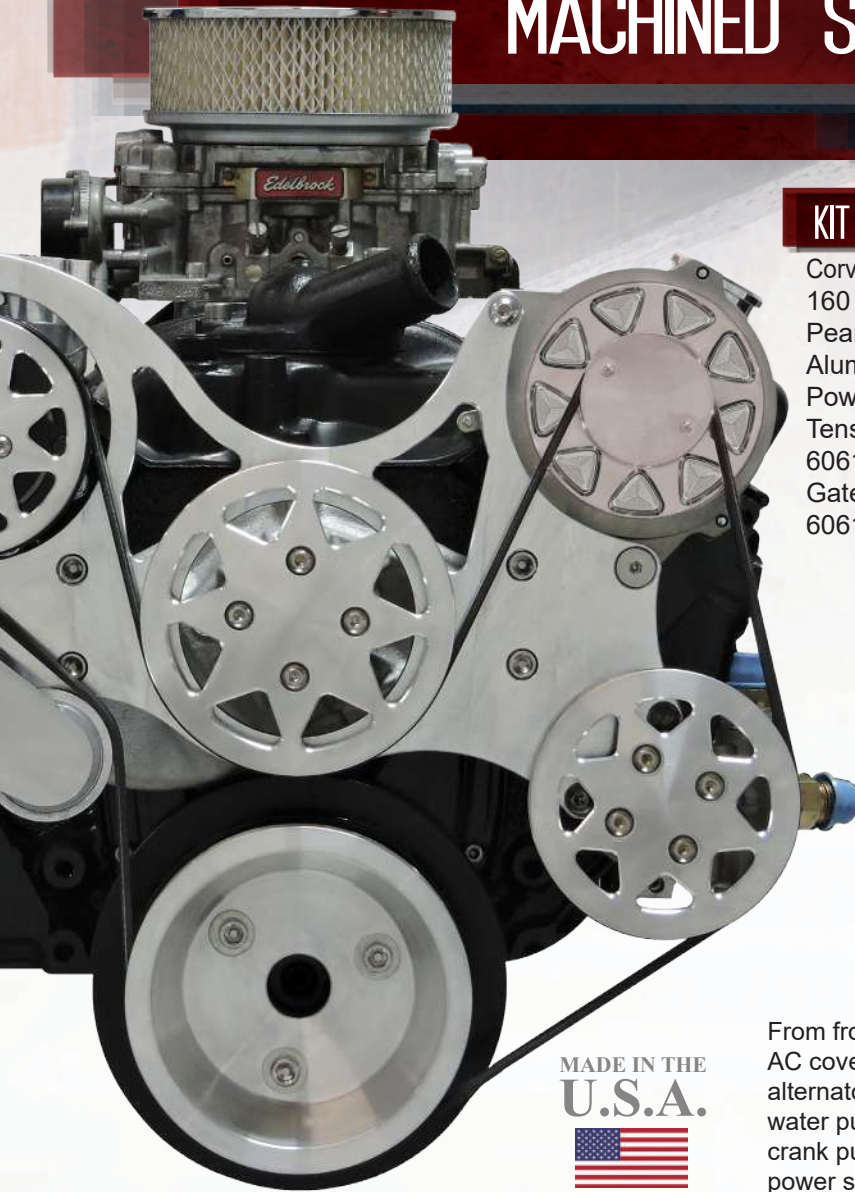

KIT INCLUDES

- Corvette Style Short Water Pump As Cast
- 160 Amp, 1 wire alternator As Cast
- Peanut Style A/C Compressor (if A/C kit)
- Aluminum Type II Power Steering Pump (if PS Kit)
- Power Steering Reservoir (if PS kit)
- Tensioner with Aluminum Cover
- 6061-T6 Aluminum Pulleys
- Gates 6-Groove Belt & Stainless Steel Hardware
- 6061-T6 Brackets

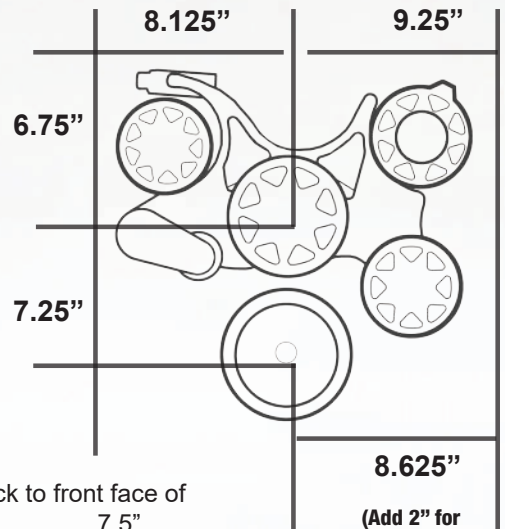

MADE IN THE
U.S.A.



- From front of block to front face of AC cover: 7.5"
- alternator pulley: 6.625"
- water pump pulley: 6.5"
- crank pulley: 6.25"
- power steering pulley: 6.5"

8.625"

(Add 2" for
On Board Res)



**Machined - With A/C
With Power Steering**
FDS-SBC-301



**Machined - With A/C
No Power Steering**
FDS-SBC-302



**Machined - No A/C
With Power Steering**
FDS-SBC-303

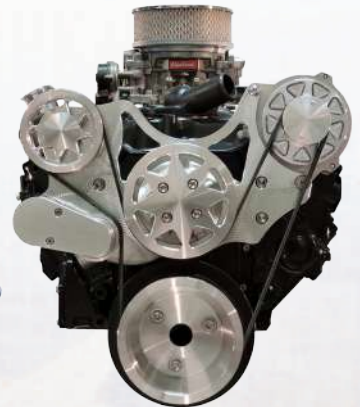

**Machined - No A/C
No Power Steering**
FDS-SBC-304

FITMENT NOTES:

*Requires factory timing cover for short water pump
85-91 Corvette factory application on water pump*

POLISHED LS 1, 2, 3, 6 + LS7

KIT WITH TUFF STUFF WATER PUMP

POLISHED - WITH A/C & POWER STEERING

FDS-LS-101

FDS-LS7-101

KIT WITH EDELBROCK WATER PUMP

POLISHED - WITH A/C & POWER STEERING

FDS-LS-101-E

FDS-LS7-101-E

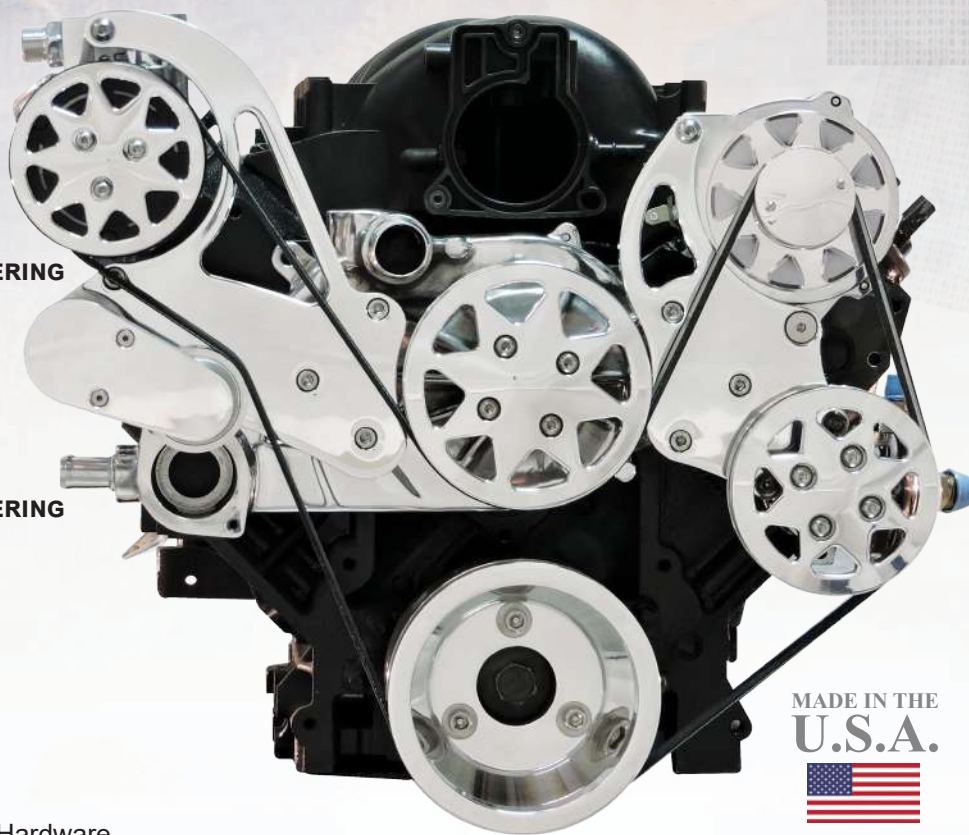

MADE IN THE
U.S.A.



KIT INCLUDES

- Aluminum Water Pump
- Polished 160 Amp, 1 wire alternator
- Gates 6-Groove Belt & Stainless Steel Hardware
- Polished Peanut Style A/C Compressor
- Polished aluminum Type II Power Steering Pump
- Polished Power Steering Reservoir
- Tensioner with Polished Aluminum Cover
- Polished 6061-T6 Aluminum Pulleys
- Fluidampr Harmonic Balancer
- Polished 6061-T6 Brackets

From front of block to face of

AC Cover:	7.5"
Alt Pulley:	6.75"
Water Pump Pulley:	6.625"
Crank Pulley:	6.5"
PS Pulley:	6.625

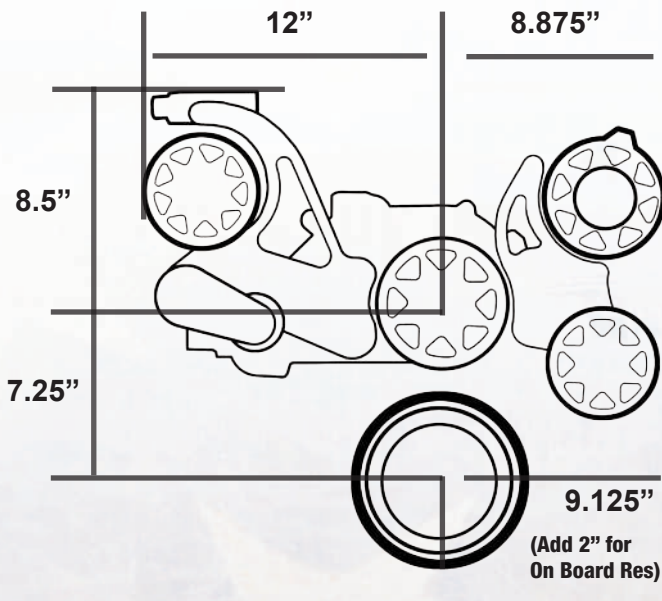

FITMENT NOTES:

LS7 setup varies from other versions - LS7 - Specify LS7 setup on order

ECM tuning required

Requires 2004 and later two piece design thermostat not included in kit (GM PN 12600172 includes seal and thermostat)

Fits all Gen III and Gen IV LS style engines - LS1, LS2, LS3, LS6, LS7, L92, L99, LQ4, LQ9, LY6, L76, LSx....etc

(Does not fit with VVT - engine can be adapted to work with setup)

SILVERLINE SERIES LS 1, 2, 3, 6 + LS7

SILVERLINE SERIES KITS WERE DESIGNED TO GIVE ANY ENGINE THAT AGGRESSIVE BLACK STYLE HIGHLIGHTED BY MACHINED FINISHED AREAS FOR A TRULY STANDOUT LOOK

KIT INCLUDES

Aluminum Water Pump
Black 160 Amp, 1 wire alternator
Fluidampr Harmonic Balancer
6061-T6 Silverline Series Brackets
6061-T6 Silverline Series Aluminum Pulleys
Black Peanut Style A/C Compressor
Gates 6-Groove Belt & Stainless Steel Hardware
Tensioner with Silverline Series Aluminum Cover
Silverline Series Power Steering Reservoir
Black Aluminum Type II Power Steering Pump

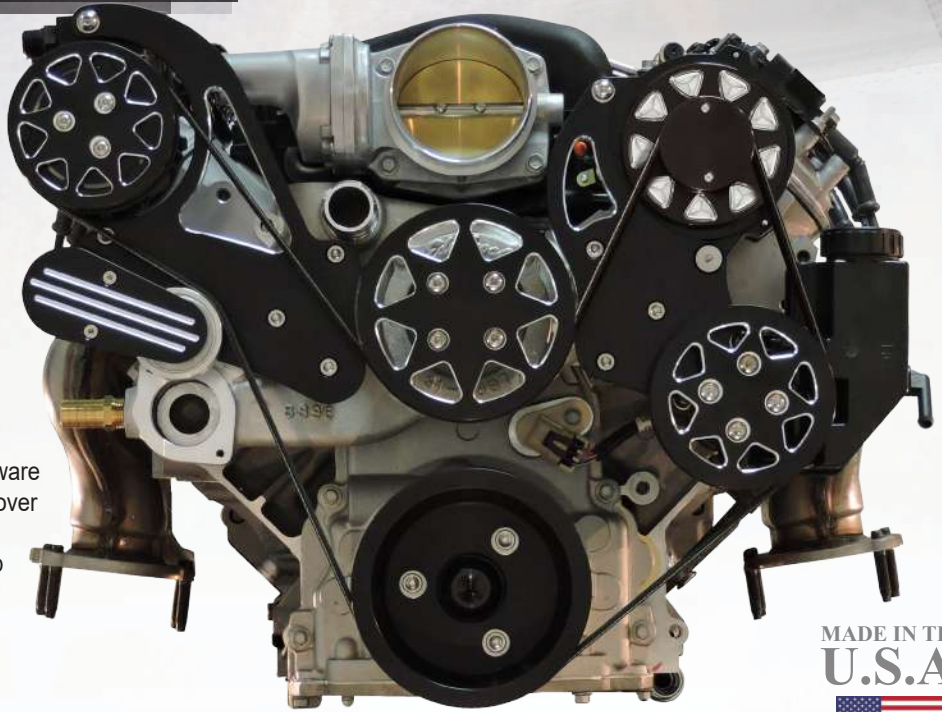

MADE IN THE
U.S.A.



KIT WITH TUFF STUFF WATER PUMP

"SILVERLINE" - WITH A/C & POWER STEERING

FDS-LS-201

FDS-LS7-201

KIT WITH EDELBROCK WATER PUMP

"SILVERLINE" - WITH A/C & POWER STEERING

FDS-LS-201-E

FDS-LS7-201-E



MACHINED LS 1, 2, 3, 6 + LS7

MACHINED KITS INCLUDE ALL COMPONENTS LISTED ABOVE (ACCESSORIES ARE CAST)



KIT WITH TUFF STUFF WATER PUMP

MACHINED - WITH A/C & POWER STEERING

FDS-LS-301

FDS-LS7-301

KIT WITH EDELBROCK WATER PUMP

MACHINED - WITH A/C & POWER STEERING

FDS-LS-301-E

FDS-LS7-301-E

POLISHED LS – NO AC, WITH POWER STEERING

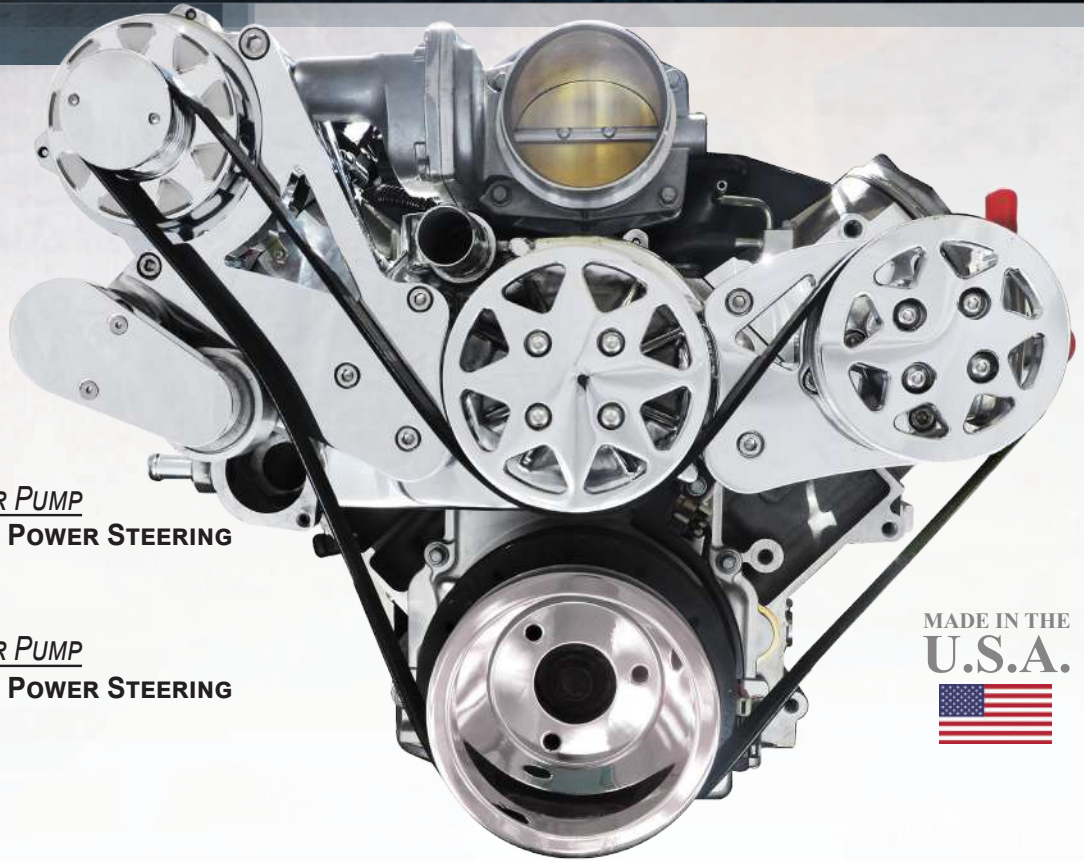

KIT WITH TUFF STUFF WATER PUMP
POLISHED - NO AC & WITH POWER STEERING
FDS-LS-103

KIT WITH EDELBROCK WATER PUMP
POLISHED - NO AC & WITH POWER STEERING
FDS-LS-103-E

MADE IN THE
U.S.A.



KIT INCLUDES

Aluminum Water Pump
Polished 160 Amp, 1 wire alternator
Polished aluminum Type II Power Steering Pump
Polished Power Steering Reservoir
Tensioner with Polished Aluminum Cover
Polished 6061-T6 Aluminum Pulleys
Fluidampr Harmonic Balancer
Polished 6061-T6 Brackets
Gates 6-Groove Belt
Stainless Steel Hardware

From front of block to face of
AC Cover: 7.5"
Alt Pulley: 6.75"
Water Pump Pulley: 6.625"
Crank Pulley: 6.5"
PS Pulley: 6.625

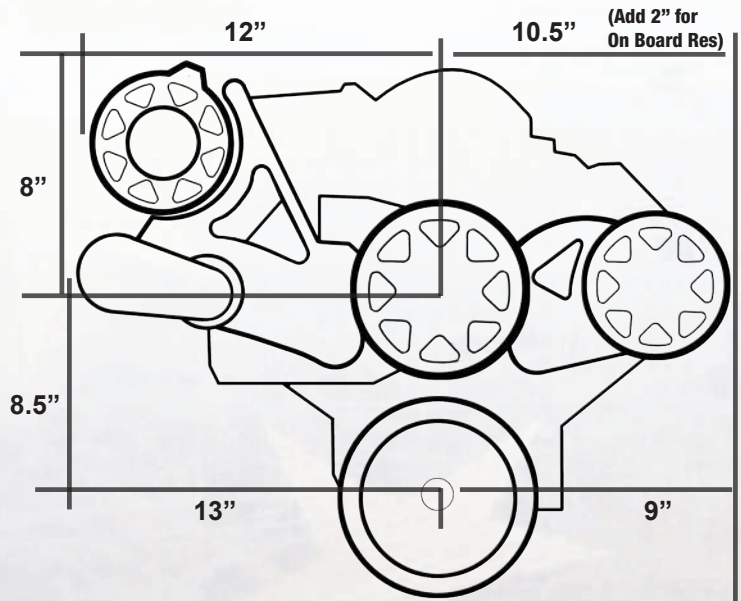

FITMENT NOTES:

ECM tuning required

Requires 2004 and later two piece design thermostat not included in kit (GM PN 12600172 includes seal and thermostat)

Fits all Gen III and Gen IV LS style engines - LS1, LS2, LS3, LS6, LS7, L92, L99, LQ4, LQ9, LY6, L76, LSx....etc

(Does not fit with VVT - engine can be adapted to work with setup)

SILVERLINE SERIES LS - NO AC, WITH POWER STEERING

SILVERLINE SERIES KITS WERE DESIGNED TO GIVE ANY ENGINE THAT AGGRESSIVE BLACK STYLE HIGHLIGHTED BY MACHINED FINISHED AREAS FOR A TRULY STANDOUT LOOK

KIT INCLUDES

Aluminum Water Pump
Black 160 Amp, 1 wire alternator
Black Aluminum Type II Power Steering Pump
Silverline Series Power Steering Reservoir
Tensioner with Silverline Series Aluminum Cover
6061-T6 Silverline Series Aluminum Pulleys
Fluidampr Harmonic Balancer
6061-T6 Silverline Series Brackets
Gates 6-Groove Belt & Stainless Steel Hardware

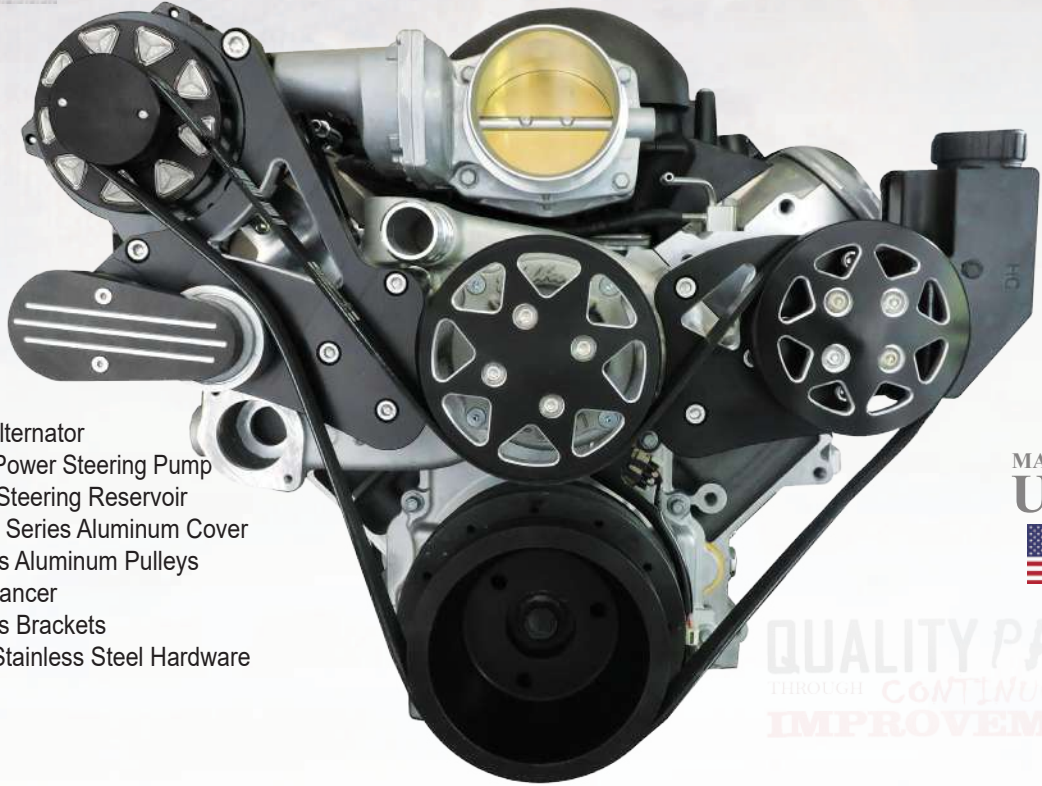

MADE IN THE
U.S.A.



QUALITY PARTS
THROUGH CONTINUOUS
IMPROVEMENT

KIT WITH TUFF STUFF WATER PUMP

"SILVERLINE" - NO AC & WITH POWER STEERING
FDS-LS-203

KIT WITH EDELBROCK WATER PUMP

"SILVERLINE" - NO AC & WITH POWER STEERING
FDS-LS-203-E

MACHINED LS - NO AC, WITH POWER STEERING

MACHINED KITS INCLUDE ALL COMPONENTS LISTED ABOVE (ACCESSORIES ARE CAST)



KIT WITH TUFF STUFF WATER PUMP

MACHINED - NO AC & WITH POWER STEERING
FDS-LS-303

KIT WITH EDELBROCK WATER PUMP

MACHINED - NO AC & WITH POWER STEERING
FDS-LS-303-E

POLISHED LSx

THIS KIT WAS DESIGN FOR ENGINE COMPARTMENTS THAT HAVE LESS SPACE IN FRONT OF THE ENGINE. THE ACCESSORIES ARE MOVED UP AND BACK FOR TIGHTER APPLICATIONS.

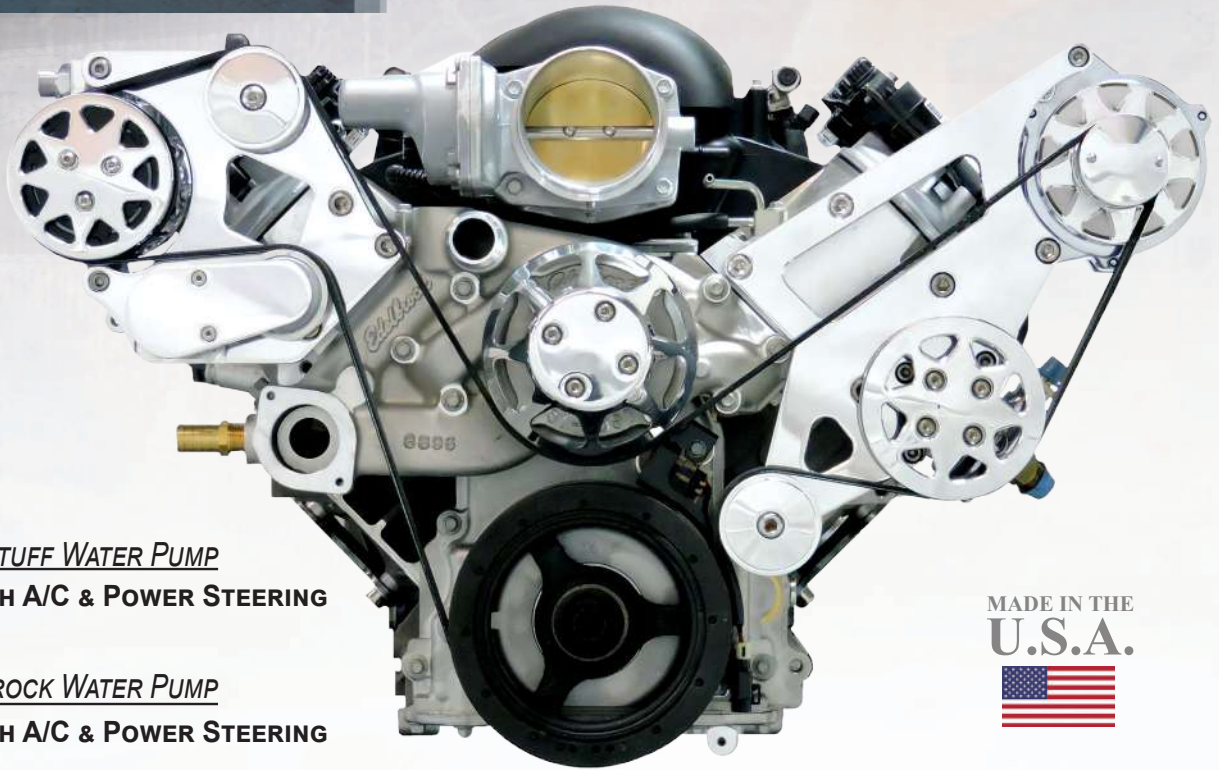

KIT WITH TUFF STUFF WATER PUMP

POLISHED - WITH A/C & POWER STEERING
FDS-LSX-101

KIT WITH EDELBROCK WATER PUMP

POLISHED - WITH A/C & POWER STEERING
FDS-LSX-101-E

MADE IN THE
U.S.A.



KIT INCLUDES

- Polished 6061-T6 Brackets
- Aluminum Water Pump as cast
- Polished 160 Amp, 1 wire alternator
- Polished Peanut Style A/C Compressor
- Polished 6061-T6 Aluminum Pulleys
- Tensioner with Polished Aluminum Cover
- Polished Remote Power Steering Reservoir
- Polished aluminum Type II Power Steering Pump
- Gates 6-Groove Belt & Stainless Steel Hardware

Timing Mounting Surface toward Front Face of:

- Crank Pulley: 4.125"
- Water Pump: 6.625"
- AC Cover: 5.125"
- Power Steering: 4.5"
- Alt Pulley: 4.25"

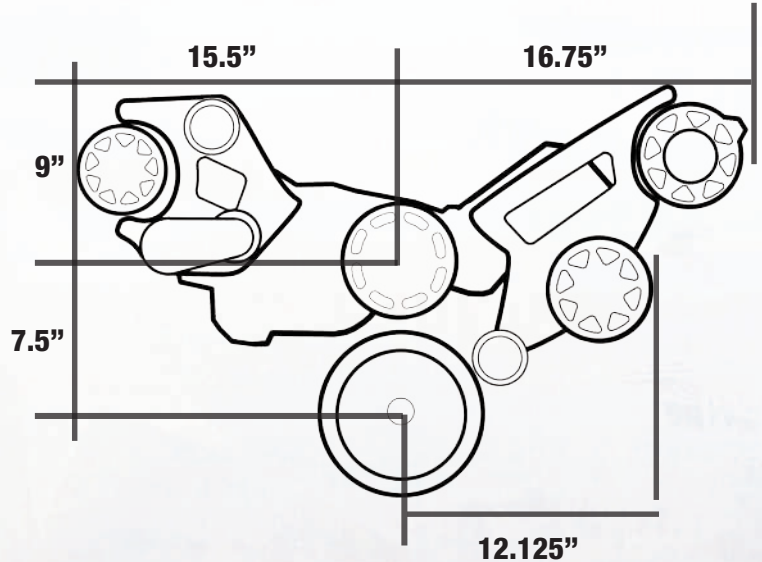

FITMENT NOTES:

- ECM tuning required - Requires 2004 and later two piece design thermostat not included in kit (GM PN 12600172 includes seal and thermostat)
- Fits all Gen III and Gen IV LS style engines (requires 1997-2013 Corvette balancer spacing or aftermarket equivalent)
- LS1, LS2, LS3, LS6, LS7, L92, L99, LQ4, LQ9, LY6, L76, LSX....etc
- (Does not fit with VVT - engine can be adapted to work with setup)
- Does not fit On-Board PS Reservoir

SILVERLINE SERIES LSx

SILVERLINE SERIES KITS WERE DESIGNED TO GIVE ANY ENGINE THAT AGGRESSIVE BLACK STYLE HIGHLIGHTED BY MACHINED FINISHED AREAS FOR A TRULY STANDOUT LOOK

KIT INCLUDES

Aluminum Water Pump as cast
Black 160 Amp, 1 wire alternator
Black Peanut Style A/C Compressor
Black Aluminum Type II Power Steering Pump
6061-T6 Silverline Series Brackets
Gates 6-Groove Belt & Stainless Steel Hardware
Silverline Series Remote Power Steering Reservoir
Tensioner with Silverline Series Aluminum Cover
6061-T6 Silverline Series Aluminum Pulleys

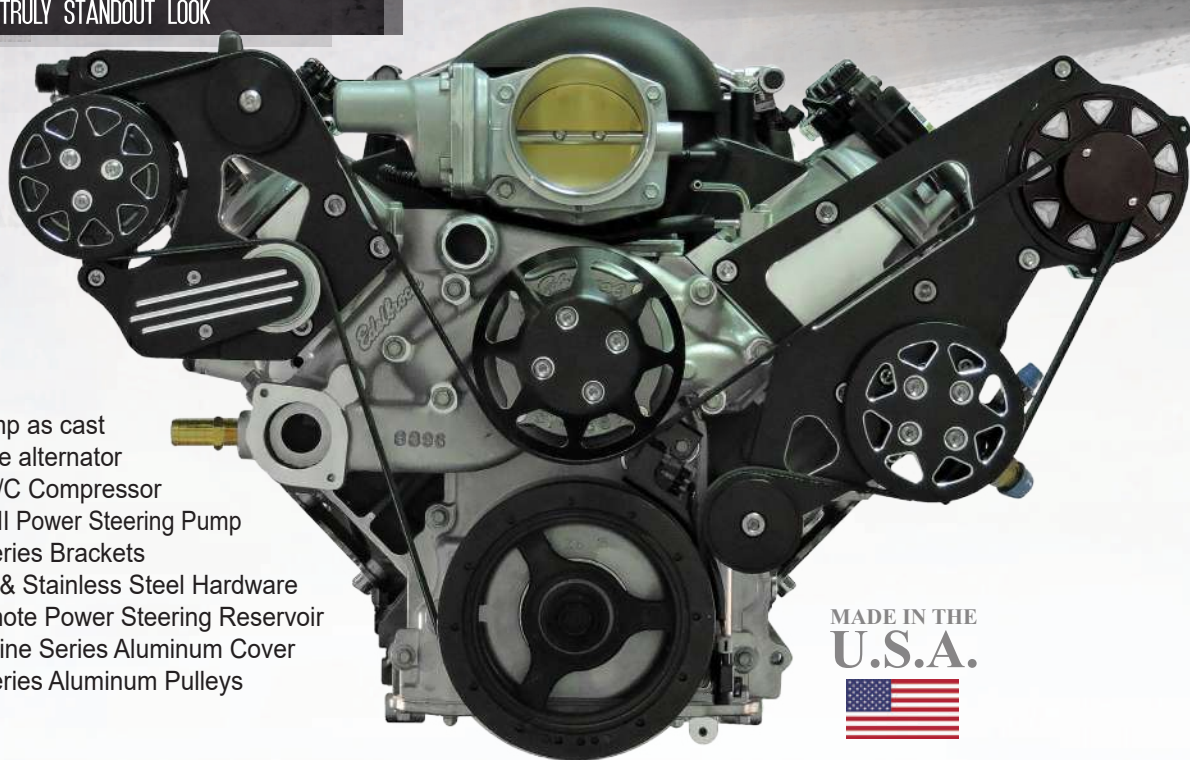

MADE IN THE
U.S.A.



KIT WITH TUFF STUFF WATER PUMP
"SILVERLINE" - WITH A/C & POWER STEERING
FDS-LSX-201

KIT WITH EDELBROCK WATER PUMP
"SILVERLINE" - WITH A/C & POWER STEERING
FDS-LSX-201-E

MACHINED LSx

MACHINED KITS INCLUDE ALL COMPONENTS LISTED ABOVE (ACCESSORIES ARE CAST)



KIT WITH TUFF STUFF WATER PUMP
MACHINED - WITH A/C & POWER STEERING
FDS-LSX-301

KIT WITH EDELBROCK WATER PUMP
MACHINED - WITH A/C & POWER STEERING
FDS-LSX-301-E



POLISHED LSA



KIT INCLUDES

- Polished 6061-T6 Brackets & Pulleys
- Polished 160 Amp, 1 wire alternator
- Polished 6061-T6 Aluminum Pulleys
- Polished Peanut Style A/C Compressor
- Tensioner with Polished Aluminum Cover
- Polished Power Remote Steering Reservoir
- Polished aluminum Type II Power Steering Pump
- Gates 6-Groove Belt & Stainless Steel Hardware



From Front of Block to:

- AC Cover: 5"
- Power Steering Pulley: 4.5"
- Alt Pulley: 4.25"
- Supercharger Tensioner Cover: 6.5"

POLISHED - With A/C & POWER STEERING FDS-LSA-101

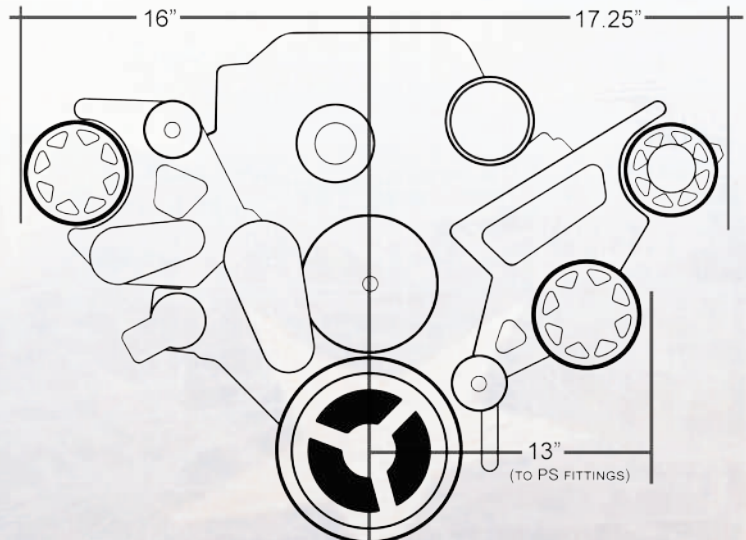

FITMENT NOTES:

14

LSA Supercharger 6.2L

SILVERLINE SERIES LSA

SILVERLINE SERIES KITS WERE DESIGNED TO GIVE ANY ENGINE THAT AGGRESSIVE BLACK STYLE HIGHLIGHTED BY MACHINED FINISHED AREAS FOR A TRULY STANDOUT LOOK

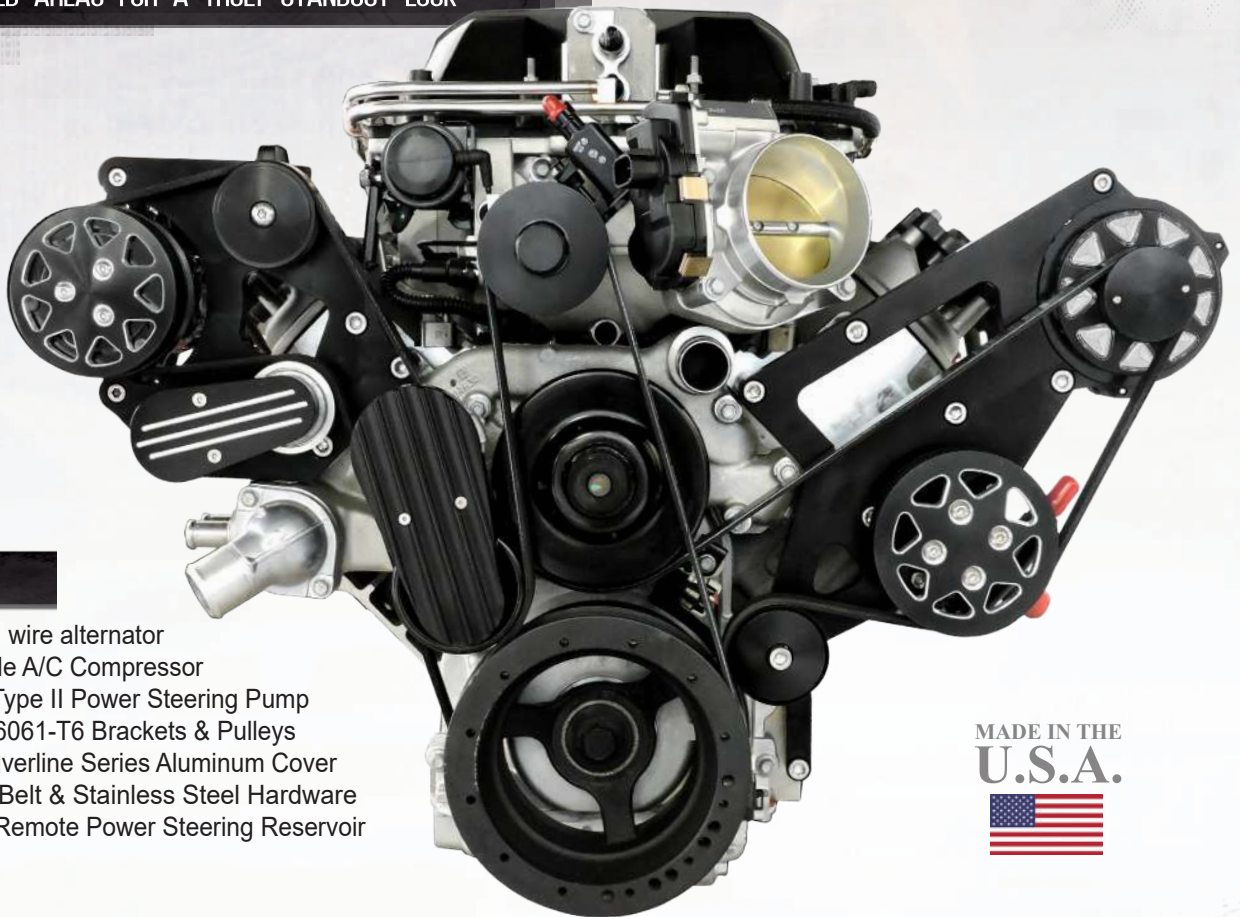

KIT INCLUDES

Black 160 Amp, 1 wire alternator
Black Peanut Style A/C Compressor
Black aluminum Type II Power Steering Pump
Silverline Series 6061-T6 Brackets & Pulleys
Tensioner with Silverline Series Aluminum Cover
Gates 6-Groove Belt & Stainless Steel Hardware
Silverline Series Remote Power Steering Reservoir

MADE IN THE
U.S.A.

SILVERLINE SERIES - With A/C & POWER STEERING
FDS-LSA-201

MACHINED LSA

MACHINED KITS INCLUDE ALL COMPONENTS LISTED ABOVE (ACCESSORIES ARE CAST)



MACHINED - With A/C & POWER STEERING
FDS-LSA-301

POLISHED LT4

MADE IN THE
U.S.A.

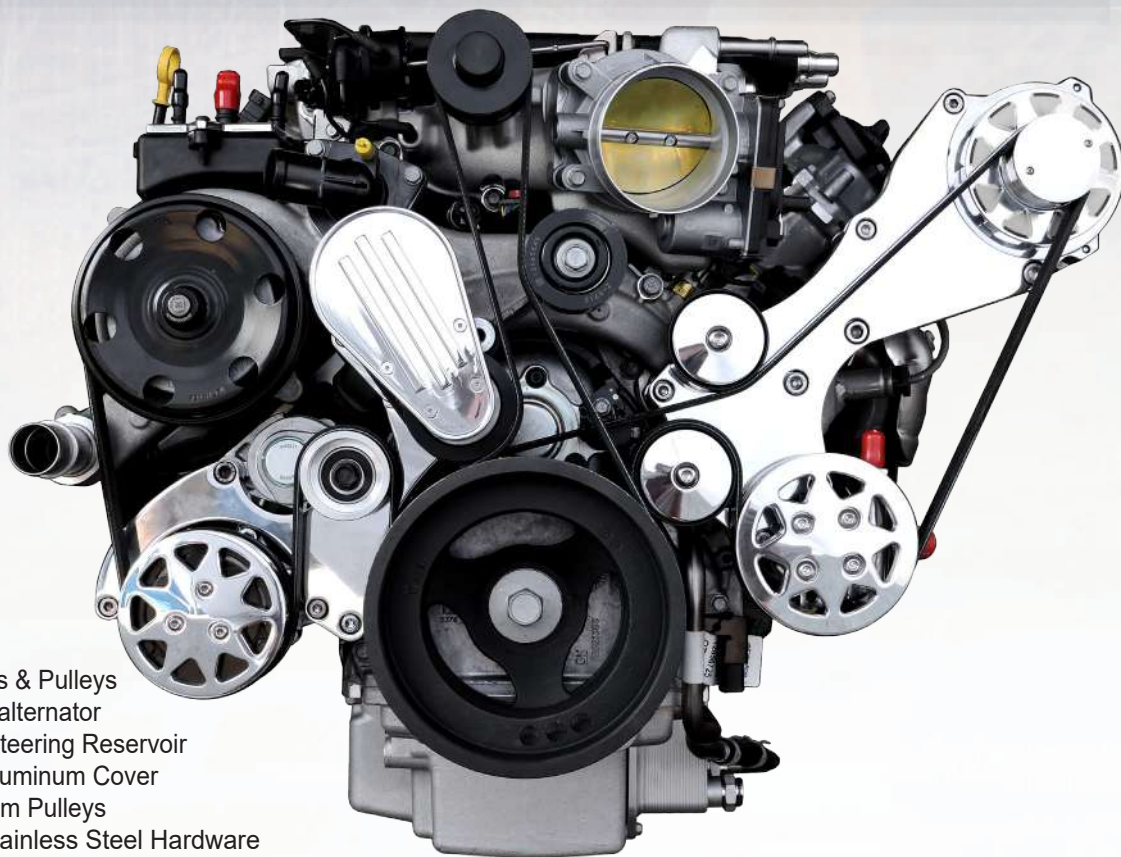

KIT INCLUDES

- Polished 6061-T6 Brackets & Pulleys
- Polished 160 Amp, 1 wire alternator
- Polished Remote Power Steering Reservoir
- Tensioner with Polished Aluminum Cover
- Polished 6061-T6 Aluminum Pulleys
- Gates 6-Groove Belt & Stainless Steel Hardware
- Polished Peanut Style A/C Compressor
- Polished aluminum Type II Power Steering Pump

From Front of Block to:

AC Cover:	3.75"
Power Steering Pulley:	3.75"
Alt Pulley:	3.75"
Water Pump Pulley:	3.75"
Tensioner Cover:	6.5"

POLISHED - With A/C & POWER STEERING
FDS-LT4-101



16

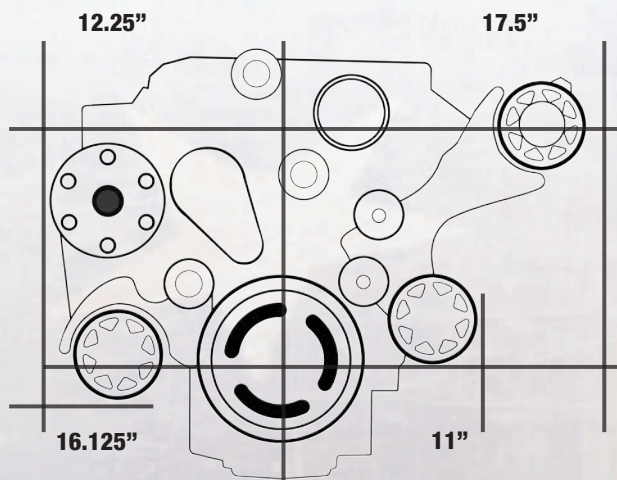

SILVERLINE SERIES LT4

SILVERLINE SERIES KITS WERE DESIGNED TO GIVE ANY ENGINE THAT AGGRESSIVE BLACK STYLE HIGHLIGHTED BY MACHINED FINISHED AREAS FOR A TRULY STANDOUT LOOK

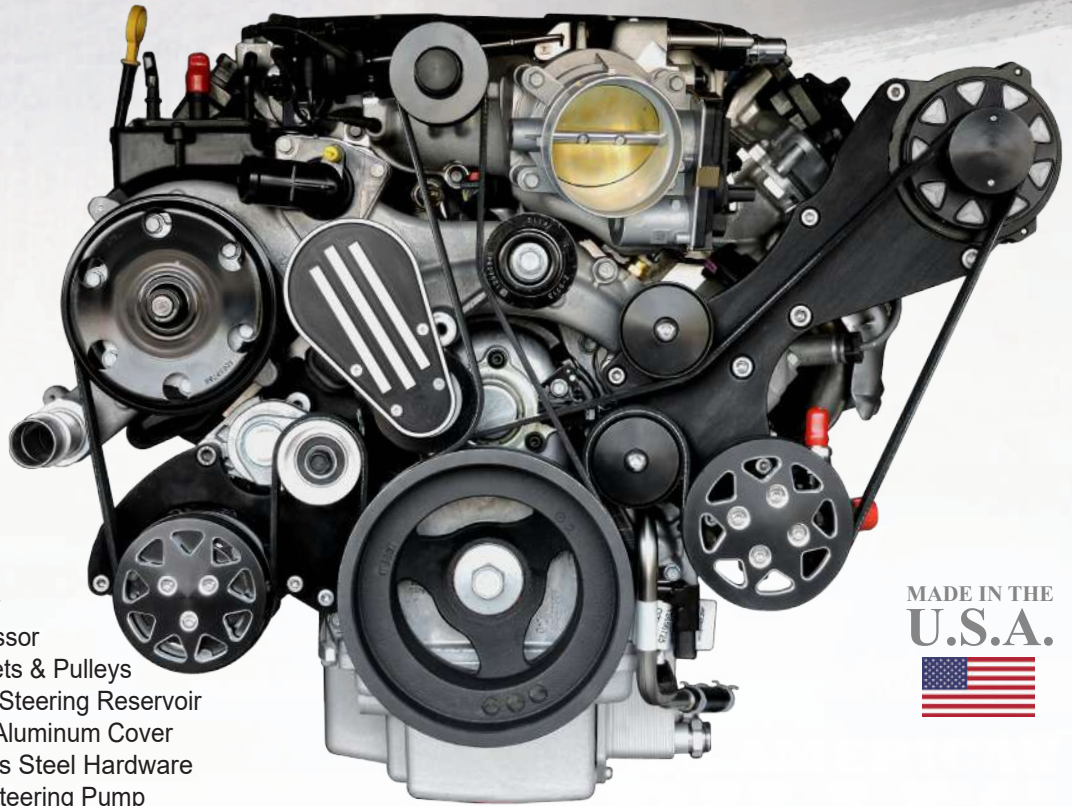

KIT INCLUDES

Black 160 Amp, 1 wire alternator
Black Peanut Style A/C Compressor
Silverline Series 6061-T6 Brackets & Pulleys
Silverline Series Remote Power Steering Reservoir
Tensioner with Silverline Series Aluminum Cover
Gates 6-Groove Belt & Stainless Steel Hardware
Black aluminum Type II Power Steering Pump

MADE IN THE
U.S.A.



SILVERLINE SERIES - With A/C & POWER STEERING
FDS-LT4-201

MACHINED LT4

MACHINED KITS INCLUDE ALL COMPONENTS LISTED ABOVE (ACCESSORIES ARE CAST)



MACHINED - With A/C & POWER STEERING
FDS-LT4-301

POLISHED LS VORTECH SUPERCHARGER

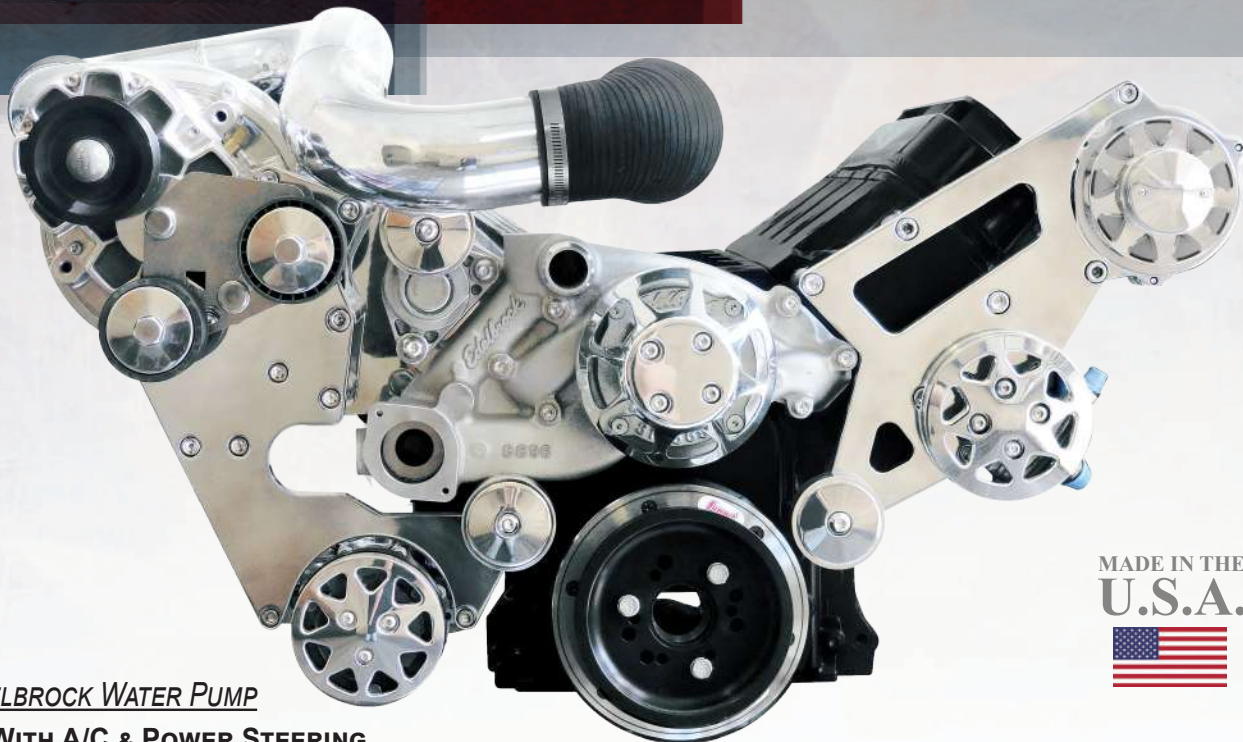

MADE IN THE
U.S.A.



KIT WITH EDELBROCK WATER PUMP

POLISHED - WITH A/C & POWER STEERING
FDS-LSV-101

KIT INCLUDES

Mandrel bent aluminum discharge tube w/ clamps & silicone sleeves
Edelbrock Aluminum Water Pump
160 Amp, 1 wire alternator
Peanut Style A/C Compressor
Aluminum Type II PS Pump
Remote Power Steering Reservoir
Aluminum Pulleys & Brackets
Gates 6-Groove Belt
High-grade mounting hardware
V-3 Si supercharger with 3.60" 10-rib pulley
(CW rotation, curved discharge, passenger side mount)
Supercharger drive assembly
Integrated manual belt tensioner with sealed bearing
tensioner pulley and 10-rib belt
Billet aluminum 10-rib supercharger crank pulley
with hard anodize finish (6" diameter)
Crank pulley spacer- (compatible with the SUM-C2501
serpentine drive Supercharger air inlet filter)
Vortech Maxflow Race Bypass Valve with filter
Aluminum mounting bracket provide rigid supercharger mounting
Includes all necessary silicone couplers, clamps and hardware

Forward from Timing Mount Face:

Crank Pulley:	6.175"
Water Pump:	6.625"
AC Cover:	5.125"
Power Steering:	4.5"
Alt Pulley:	4.25"
Lower Idler:	4.25"
Upper Idler:	4.125"

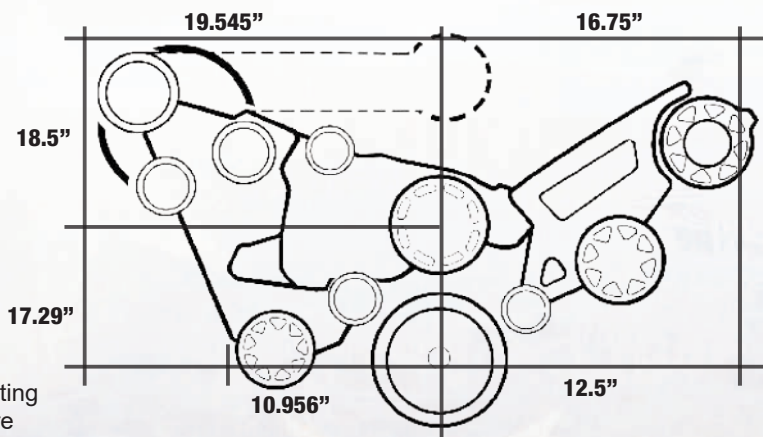

FITMENT NOTES

*Fits all Gen III and Gen IV LS style engines LS1, LS2, LS3, LS6, LS7, L92, L99, LQ4, LQ9, LY6, L76, LSx....etc
(Does not fit with VVT - engine can be adapted to work with setup)*

Supplied pulley ratio will produce approximately 8-10 psi @ 6000 RPM on a typical LS1, LS2

Horsepower gains (dependent on engine size) 30-75+ %

Designed for vehicles equipped with fuel injected Chevrolet engines using LS1, LS2 style intake manifold

SILVERLINE SERIES LS VORTECH SUPERCHARGER

SILVERLINE SERIES KITS WERE DESIGNED TO GIVE ANY ENGINE THAT AGGRESSIVE BLACK STYLE HIGHLIGHTED BY MACHINED FINISHED AREAS FOR A TRULY STANDOUT LOOK



KIT INCLUDES

Supercharger drive assembly
Edelbrock Aluminum Water Pump
Black 160 Amp, 1 wire alternator
Black Peanut Style A/C Compressor
Aluminum Type II PS Pump
Remote Power Steering Reservoir
Silverline Series Pulleys & Brackets
Gates 6-Groove Belt
High-grade mounting hardware
V-3 Si supercharger with 3.60" 10-rib pulley (CW rotation, curved discharge, passenger side mount)
Mandrel bent aluminum discharge tube w/ clamps & silicone sleeves
Integrated manual belt tensioner with sealed bearing tensioner Silverline Series pulley and 10-rib belt
Black Billet aluminum 10-rib supercharger crank pulley with hard anodize finish (6" diameter)
Crank pulley spacer- (compatible with the SUM-C2501 serpentine drive Supercharger air inlet filter)
Vortech Maxflow Race Bypass Valve with filter
Aluminum mounting bracket provide rigid supercharger mounting
Includes all necessary silicone couplers, clamps and hardware

KIT WITH EDELBROCK WATER PUMP

"SILVERLINE" - WITH A/C & POWER STEERING

FDS-LSV-201

MADE IN THE
U.S.A.



LS VORTECH REQUIREMENTS

Engine calibration
New Thermostat (2004-later two piece design)
Straight Style Thermostat Housing (ex. Mr Gasket P/N - 2671)
1/2" NPT 45 degree heater hose fitting
Fuel system - Fuel Lines (-6 or larger)
Fuel Pressure Regulator (Boost reference style)
Fuel Pump (340lph or larger)
Fuel Injectors (42lbs or larger)
Fuel Filter (capable to handle higher flow)
3/8" NPT 90 degree heater hose fitting
1/2" NPT 45 degree heater hose fitting

MACHINED LS VORTECH SUPERCHARGER

MACHINED KITS INCLUDE ALL COMPONENTS LISTED ABOVE (ACCESSORIES ARE CAST)



KIT WITH EDELBROCK WATER PUMP

MACHINED - WITH A/C & POWER STEERING

FDS-LSV-301

POLISHED BIG BLOCK CHEVY



**Polished - With A/C
With Power Steering**
FDS-BBC-101

**Polished - With A/C
No Power Steering**
FDS-BBC-102

**Polished - No A/C
With Power Steering**
FDS-BBC-103

**Polished - No A/C
No Power Steering**
FDS-BBC-104

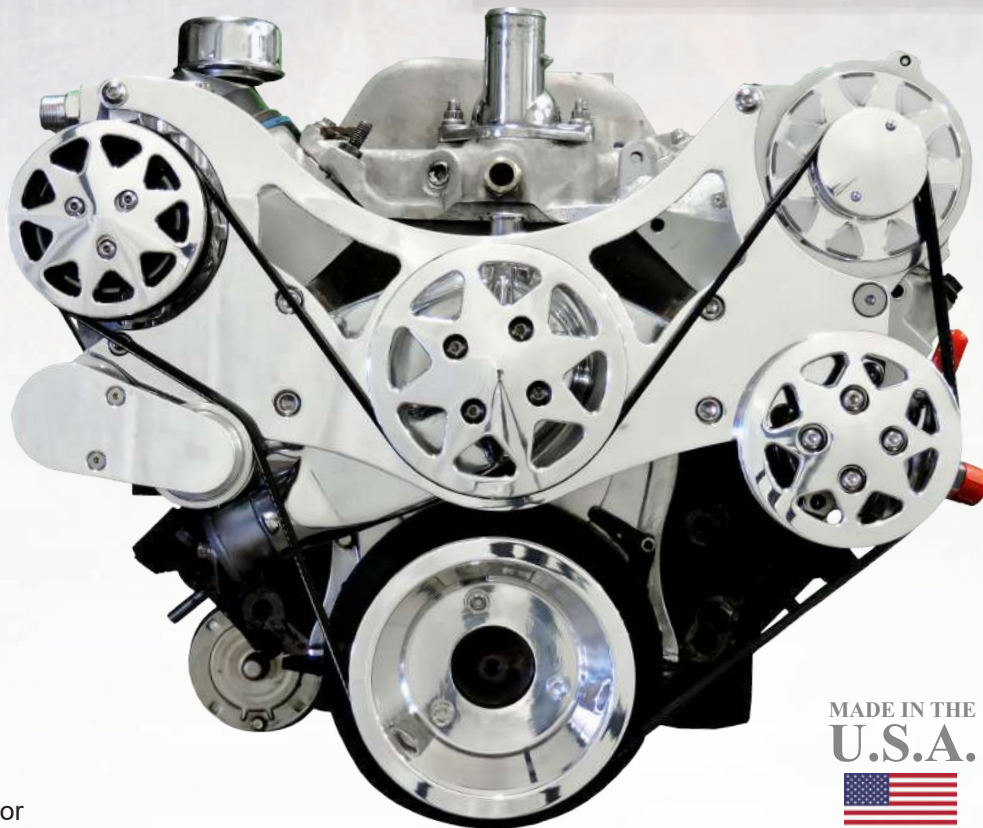

MADE IN THE
U.S.A.

KIT INCLUDES

- Aluminum Water Pump as Cast
- Polished 160 Amp, 1 wire alternator
- Polished Peanut Style A/C Compressor (if A/C kit)
- Polished aluminum Type II Power Steering Pump (if PS Kit)
- Polished Power Steering Reservoir (if PS kit)
- Gates 6-Groove Belt & Stainless Steel Hardware
- Tensioner with Polished Aluminum Cover
- Polished 6061-T6 Aluminum Pulleys
- Polished 6061-T6 Brackets

From front of block to face of:

Crank Pulley:	4.125"
AC Cover:	7.25"
Alt Pulley:	6.3125"
Water Pump Pulley:	6.375"
Crank Pulley:	6.25"
PS Pulley:	6.375"

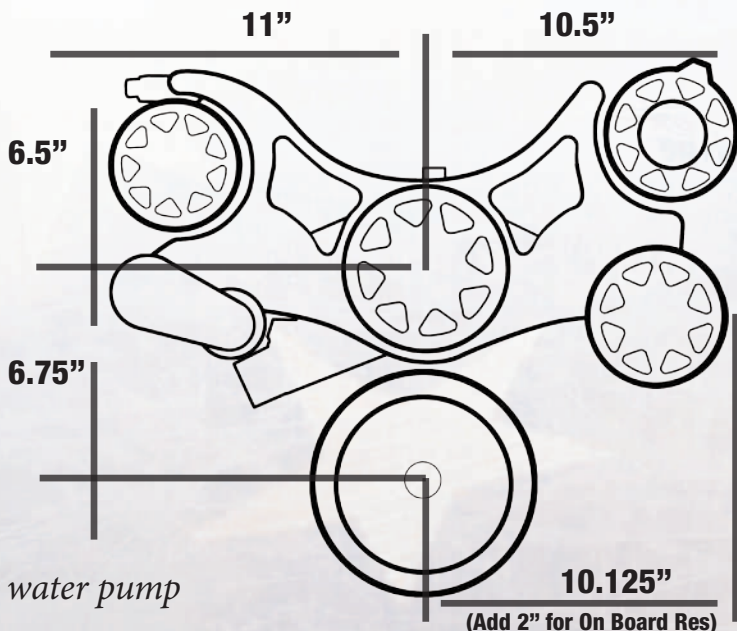

FITMENT NOTES:

Note 65-72 factory Big Block short fitment on water pump

SILVERLINE SERIES BIG BLOCK CHEVY

SILVERLINE SERIES KITS WERE DESIGNED TO GIVE ANY ENGINE THAT AGGRESSIVE BLACK STYLE HIGHLIGHTED BY MACHINED FINISHED AREAS FOR A TRULY STANDOUT LOOK

MADE IN THE
U.S.A.

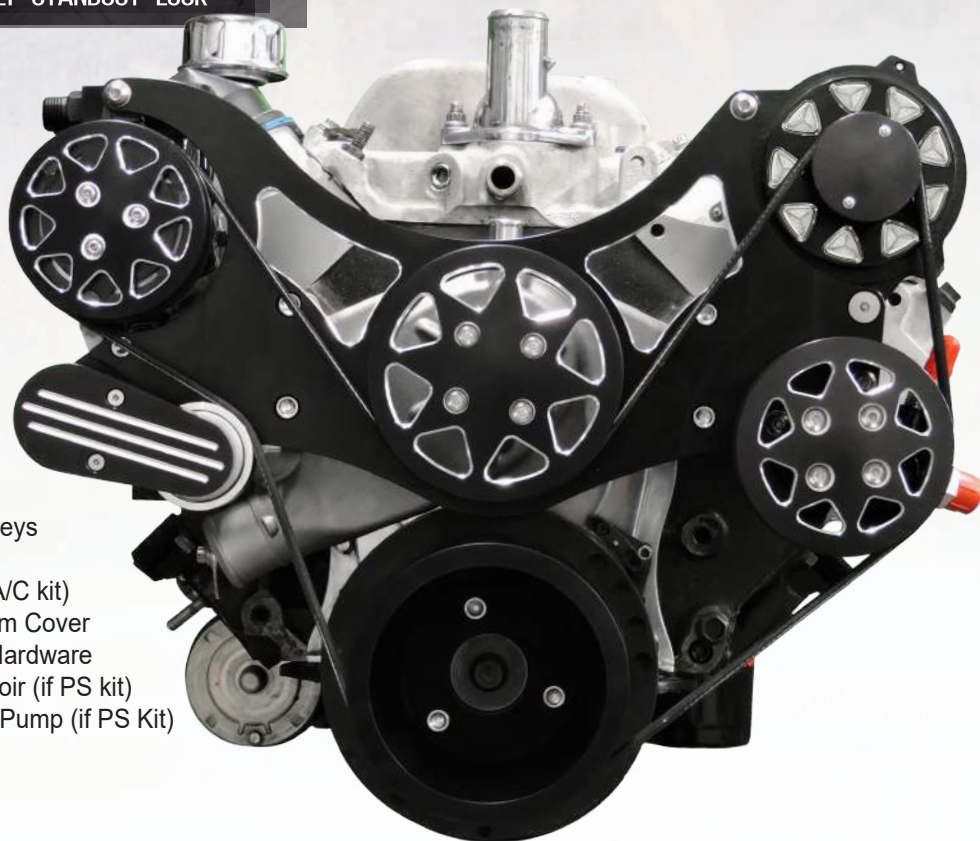

KIT INCLUDES

Aluminum Water Pump as Cast
Black 160 Amp, 1 wire alternator
6061-T6 Silverline Series Aluminum Pulleys
6061-T6 Silverline Series Brackets
Black Peanut Style A/C Compressor (if A/C kit)
Tensioner with Silverline Series Aluminum Cover
Gates 6-Groove Belt & Stainless Steel Hardware
Silverline Series Power Steering Reservoir (if PS kit)
Black Aluminum Type II Power Steering Pump (if PS Kit)

**Silverline Series - With A/C
With Power Steering**
FDS-BBC-201

**Silverline Series - With A/C
No Power Steering**
FDS-BBC-202

**Silverline Series - No A/C
With Power Steering**
FDS-BBC-203

**Silverline Series - No A/C
No Power Steering**
FDS-BBC-204



MACHINED BIG BLOCK CHEVY

MACHINED KITS INCLUDE ALL COMPONENTS LISTED ABOVE (ACCESSORIES ARE CAST)



**Machined - With A/C
With Power Steering**
FDS-BBC-301

**Machined - With A/C
No Power Steering**
FDS-BBC-302

**Machined - No A/C
With Power Steering**
FDS-BBC-303

**Machined - No A/C
No Power Steering**
FDS-BBC-304

POLISHED SMALL BLOCK FORD

**Polished - With A/C
With Power Steering**
FDS-SBF-101

**Polished - With A/C
No Power Steering**
FDS-SBF-102

**Polished - No A/C
With Power Steering**
FDS-SBF-103

**Polished - No A/C
No Power Steering**
FDS-SBF-104



MADE IN THE
U.S.A.



KIT INCLUDES

- Aluminum Water Pump
- Aluminum Timing Cover
- Polished 6061-T6 Brackets
- Polished 160 Amp, 1 wire alternator
- Polished Peanut Style A/C Compressor (if A/C kit)
- Polished Aluminum Type II Power Steering Pump (If PS Kit)
- Polished Remote Power Steering Reservoir (if PS kit)
- Tensioner with Polished Aluminum Cover
- Polished 6061-T6 Aluminum Pulleys
- Gates 6-Groove Belt & Stainless Steel Hardware

From front of block to front face of:

AC cover:	8.25"
alternator pulley:	7.625"
water pump pulley:	8.625"
water pump pulley:	8.625"
crank pulley:	7.25"
power steering pulley:	7.625"

FITMENT NOTES:

- Fits All Windsor Engines - 260, 289, 302, 351w, 5L.*
- Includes timing cover (MUST USE)*
- 90 degree thermostat housing recommended*
- Note 86-91 Mustang water pump fitment*
- Requires 4 bolt 6.4" diameter, 3.950" length crank damper*
- Retains mechanical fuel pump (includes block off)*
- Retains dipstick provision in timing cover (includes block off)*

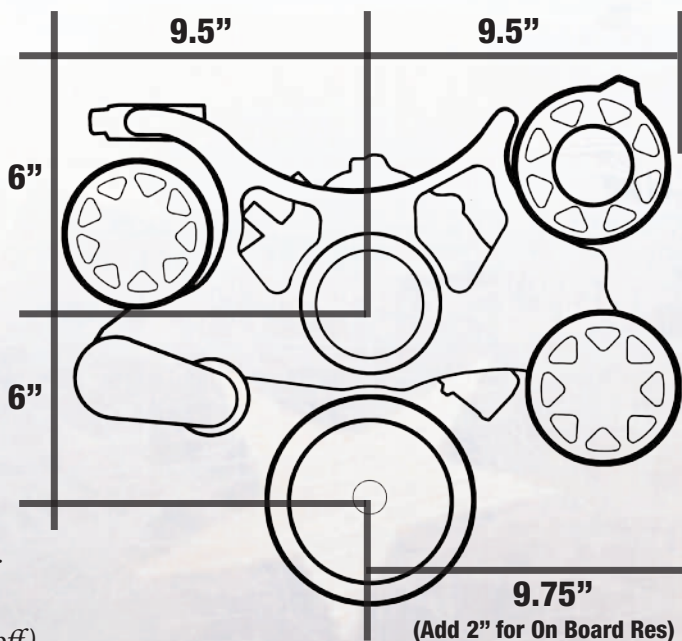

SILVERLINE SERIES SMALL BLOCK FORD

SILVERLINE SERIES KITS WERE DESIGNED TO GIVE ANY ENGINE THAT AGGRESSIVE BLACK STYLE HIGHLIGHTED BY MACHINED FINISHED AREAS FOR A TRULY STANDOUT LOOK



MADE IN THE
U.S.A.

KIT INCLUDES

- Aluminum Timing Cover
- Black 160 Amp, 1 wire alternator
- 6061-T6 Silverline Series Brackets
- Aluminum Reverse Rotation Water Pump
- 6061-T6 Silverline Series Aluminum Pulleys
- Black Peanut Style A/C Compressor (if A/C kit)
- Tensioner with Silverline Series Aluminum Cover
- Gates 6-Groove Belt & Stainless Steel Hardware
- Silverline Series Power Steering Reservoir (if PS kit)
- Black Aluminum Type II Remote Power Steering Pump (If PS Kit)

**Silverline Series - With A/C
With Power Steering**
FDS-SBF-201

**Silverline Series - With A/C
No Power Steering**
FDS-SBF-202

**Silverline Series - No A/C
With Power Steering**
FDS-SBF-203

**Silverline Series - No A/C
No Power Steering**
FDS-SBF-204



MACHINED SMALL BLOCK FORD

MACHINED KITS INCLUDE ALL COMPONENTS LISTED ABOVE (ACCESSORIES ARE CAST)



**Machined - With A/C
With Power Steering**
FDS-SBF-301

**Machined - With A/C
No Power Steering**
FDS-SBF-302

**Machined - No A/C
With Power Steering**
FDS-SBF-303

**Machined - No A/C
No Power Steering**
FDS-SBF-304

POLISHED FORD FE

**Polished - With A/C
With Power Steering**
FDS-FE-101

**Polished - With A/C
No Power Steering**
FDS-FE-102

**Polished - No A/C
With Power Steering**
FDS-FE-103

**Polished - No A/C No
Power Steering**
FDS-FE-104

MADE IN THE
U.S.A.



KIT INCLUDES

Polished 6061-T6 Brackets
Polished 160 Amp, 1 wire alternator
Polished 6061-T6 Aluminum Pulleys
Tensioner with Polished Aluminum Cover
Aluminum Reverse Rotation Water Pump
Polished Power Steering Reservoir (if PS kit)
Polished Peanut Style A/C Compressor (if A/C kit)
Polished Aluminum Type II Power Steering Pump (if PS Kit)
Gates 6-Groove Belt & Stainless Steel Hardware

From water pump mounting surface to front face of:

AC cover:	8"
alternator pulley:	7.125"
water pump pulley:	8.125"
crank pulley:	7.125"
power steering pulley:	7.25"

FITMENT NOTES:

*Fits 1965-1976 390ci/427ci/428ci Ford FE based engines
Requires later style FE crank damper (not included in kit)*

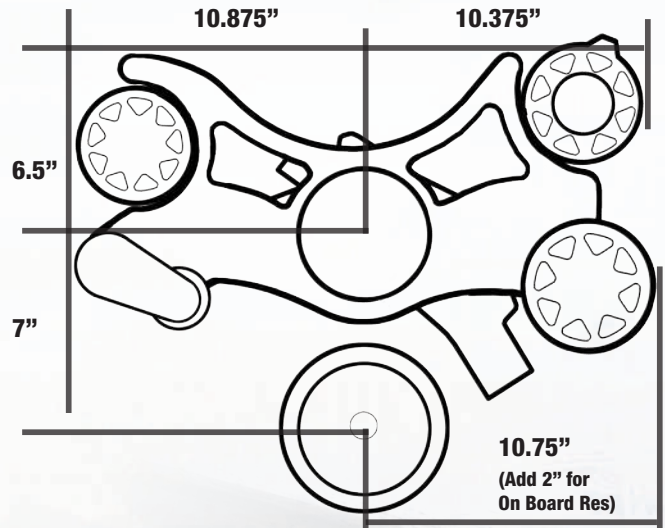

SILVERLINE SERIES FORD FE

SILVERLINE SERIES KITS WERE DESIGNED TO GIVE ANY ENGINE THAT AGGRESSIVE BLACK STYLE HIGHLIGHTED BY MACHINED FINISHED AREAS FOR A TRULY STANDOUT LOOK

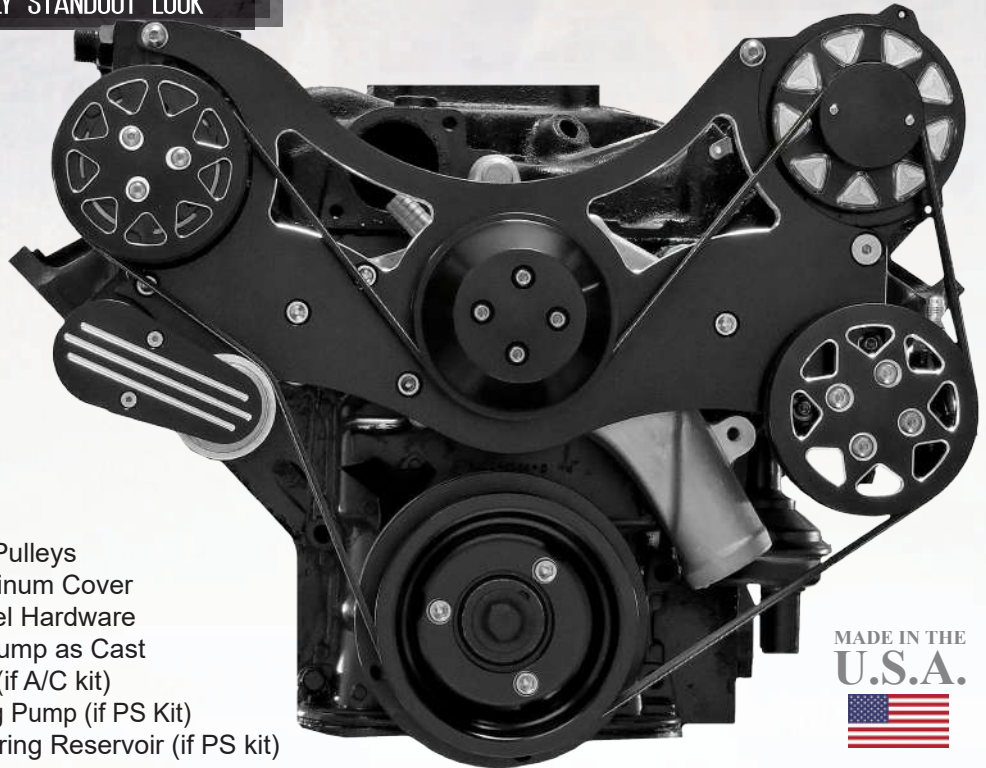

MADE IN THE
U.S.A.

KIT INCLUDES

Black 160 Amp, 1 wire alternator
6061-T6 Silverline Series Brackets
6061-T6 Silverline Series Aluminum Pulleys
Tensioner with Silverline Series Aluminum Cover
Gates 6-Groove Belt & Stainless Steel Hardware
Aluminum Reverse Rotation Water Pump as Cast
Black Peanut Style A/C Compressor (if A/C kit)
Black Aluminum Type II Power Steering Pump (if PS Kit)
Silverline Series Remote Power Steering Reservoir (if PS kit)

**Silverline Series - With A/C
With Power Steering**
FDS-FE-201

**Silverline Series - With A/C
No Power Steering**
FDS-FE-202

**Silverline Series - No A/C
With Power Steering**
FDS-FE-203

**Silverline Series - No A/C
No Power Steering**
FDS-FE-204

MACHINED FORD FE

MACHINED KITS INCLUDE ALL COMPONENTS LISTED ABOVE (ACCESSORIES ARE CAST)



**Machined - With A/C
With Power Steering**
FDS-FE-301

**Machined - With A/C
No Power Steering**
FDS-FE-302

**Machined - No A/C
With Power Steering**
FDS-FE-303

**Machined - No A/C
No Power Steering**
FDS-FE-304

POLISHED BIG BLOCK FORD

**Polished - With A/C
With Power Steering**
FDS-BBF-101

**Polished - No A/C
With Power Steering**
FDS-BBF-103

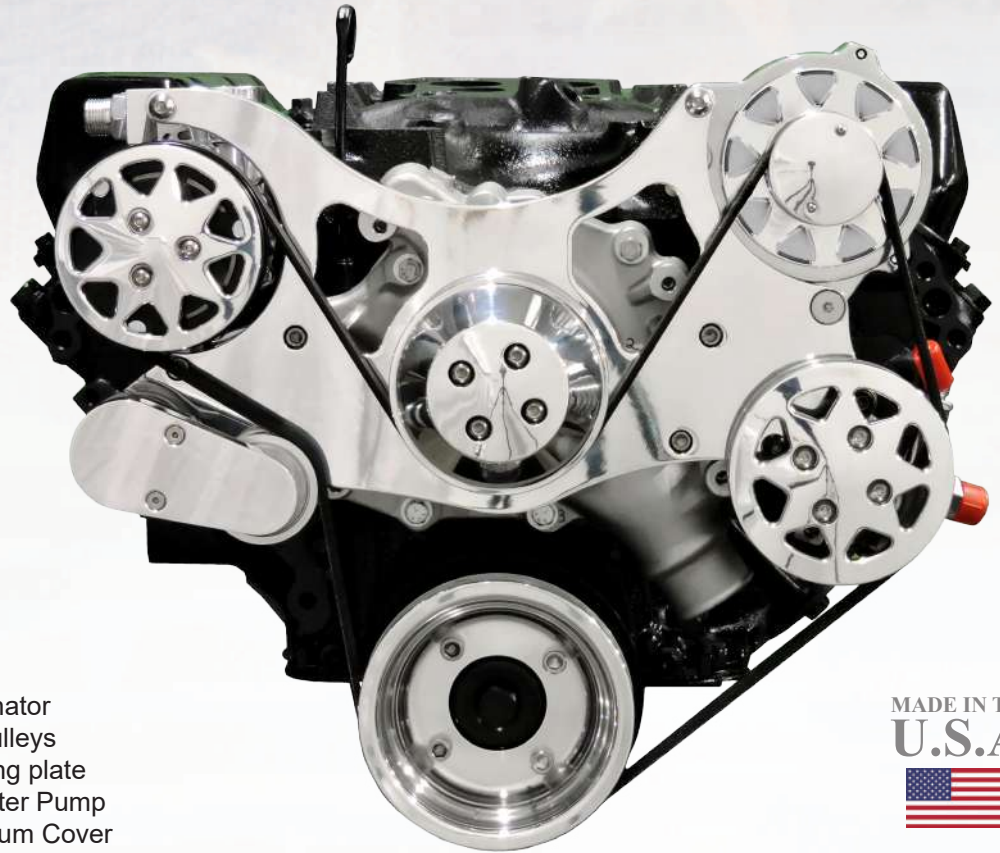

KIT INCLUDES

Polished 6061-T6 Brackets
Polished 160 Amp, 1 wire alternator
Polished 6061-T6 Aluminum Pulleys
Ford Racing water pump backing plate
Cast Iron Reverse Rotation Water Pump
Tensioner with Polished Aluminum Cover
Gates 6-Groove Belt & Stainless Steel Hardware
Polished Peanut Style A/C Compressor (if A/C kit)
Polished Power Steering Reservoir (if PS kit)
Polished aluminum Type II Power Steering Pump (if PS Kit)

MADE IN THE
U.S.A.



From front of block to front face of:

A/C Cover:	8.375"
Alt Pulley:	7.25"
Water Pump Pulley:	8.5"
Crank Pulley:	7.125"
PS Pulley:	7.5"

FITMENT NOTES:

*Reverse rotation, high flow cast water pump
Includes Ford Racing water pump backing plate
Retains mechanical fuel pump
Retains dipstick in timing cover
Requires factory dimensions crank damper*

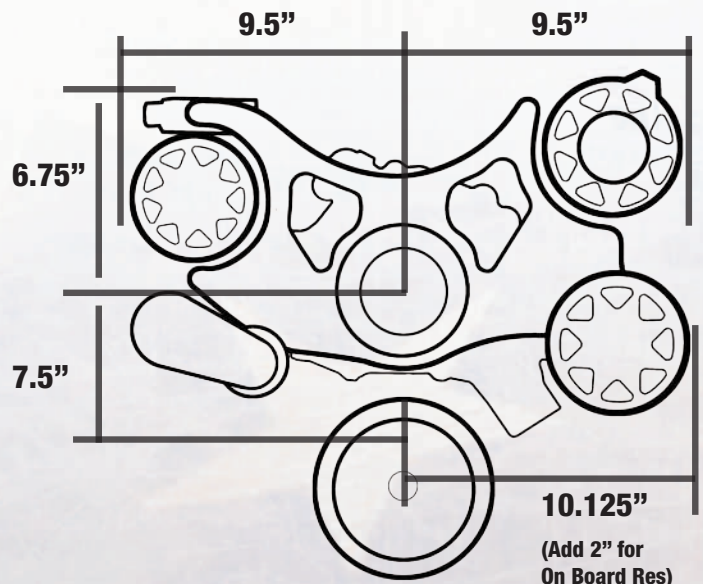

SILVERLINE SERIES BIG BLOCK FORD

SILVERLINE SERIES KITS WERE DESIGNED TO GIVE ANY ENGINE THAT AGGRESSIVE BLACK STYLE HIGHLIGHTED BY MACHINED FINISHED AREAS FOR A TRULY STANDOUT LOOK

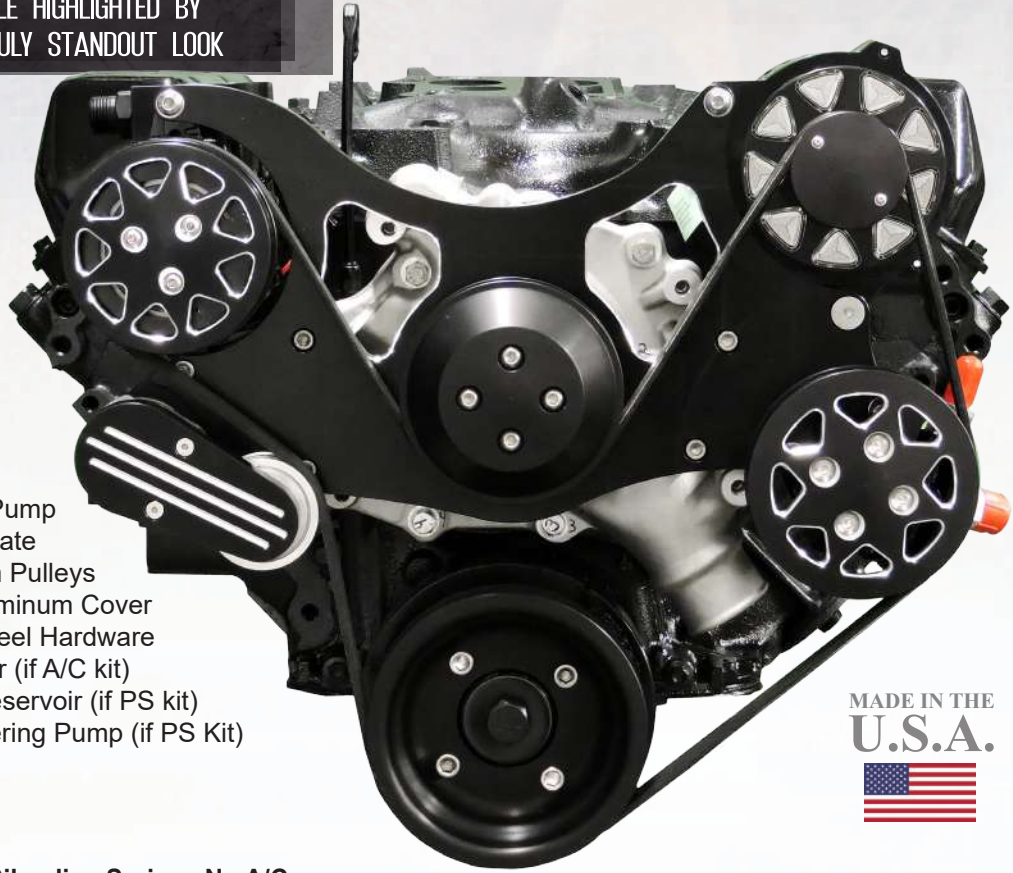

KIT INCLUDES

Black 160 Amp, 1 wire alternator
6061-T6 Silverline Series Brackets
Cast Iron Reverse Rotation Water Pump
Ford Racing water pump backing plate
6061-T6 Silverline Series Aluminum Pulleys
Tensioner with Silverline Series Aluminum Cover
Gates 6-Groove Belt & Stainless Steel Hardware
Black Peanut Style A/C Compressor (if A/C kit)
Silverline Series Power Steering Reservoir (if PS kit)
Black Aluminum Type II Power Steering Pump (if PS Kit)

MADE IN THE
U.S.A.

**Silverline Series - With A/C
With Power Steering**
FDS-BBF-201

**Silverline Series - No A/C
With Power Steering**
FDS-BBF-203

MACHINED BIG BLOCK FORD

MACHINED KITS INCLUDE ALL COMPONENTS LISTED ABOVE (ACCESSORIES ARE CAST)



**Machined - With A/C
With Power Steering**
FDS-BBF-301

**Machined - No A/C
With Power Steering**
FDS-BBF-303

POLISHED 351 CLEVELAND

**Polished - With A/C
With Power Steering**
FDS-351-101



KIT INCLUDES

- Cast Reverse Rotation Water Pump
- Polished 160 Amp, 1 wire alternator
- Polished 6061-T6 Brackets
- Polished 6061-T6 Aluminum Pulleys
- Polished Peanut Style A/C Compressor (if A/C kit)
- Polished aluminum Type II Power Steering Pump (if PS Kit)
- Polished Power Steering Reservoir (if PS kit)
- Tensioner with Polished Aluminum Cover
- Gates 6-Groove Belt & Stainless Steel Hardware

MADE IN THE
U.S.A.



From front of block to front face of	
AC cover:	8"
Alt pulley:	8"
Water pump pulley:	8.5"
Crank pulley:	7.25"
PS pulley:	7.25"
Tensioner:	8"

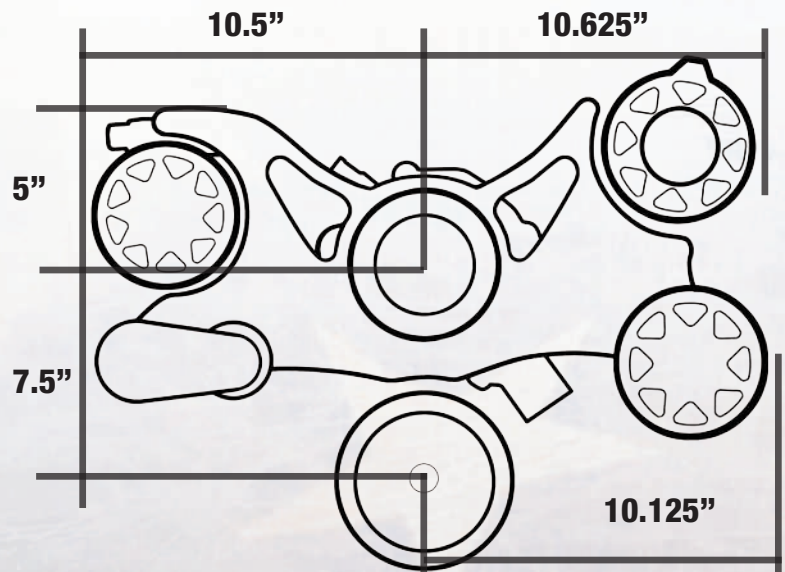

FITMENT NOTES:

Fits 70-82 351C/M and 400M
Retains factory dipstick location

(Add 2" for
On Board Res)

SILVERLINE SERIES 351 CLEVELAND

SILVERLINE SERIES KITS WERE DESIGNED TO GIVE ANY ENGINE THAT AGGRESSIVE BLACK STYLE HIGHLIGHTED BY MACHINED FINISHED AREAS FOR A TRULY STANDOUT LOOK

KIT INCLUDES

Black 160 Amp, 1 wire alternator
6061-T6 Silverline Series Brackets
Cast Reverse Rotation Water Pump
6061-T6 Silverline Series Aluminum Pulleys
Black Peanut Style A/C Compressor (if A/C kit)
Tensioner with Silverline Series Aluminum Cover
Gates 6-Groove Belt & Stainless Steel Hardware
Silverline Series Power Steering Reservoir (if PS kit)
Black Aluminum Type II Power Steering Pump (if PS Kit)

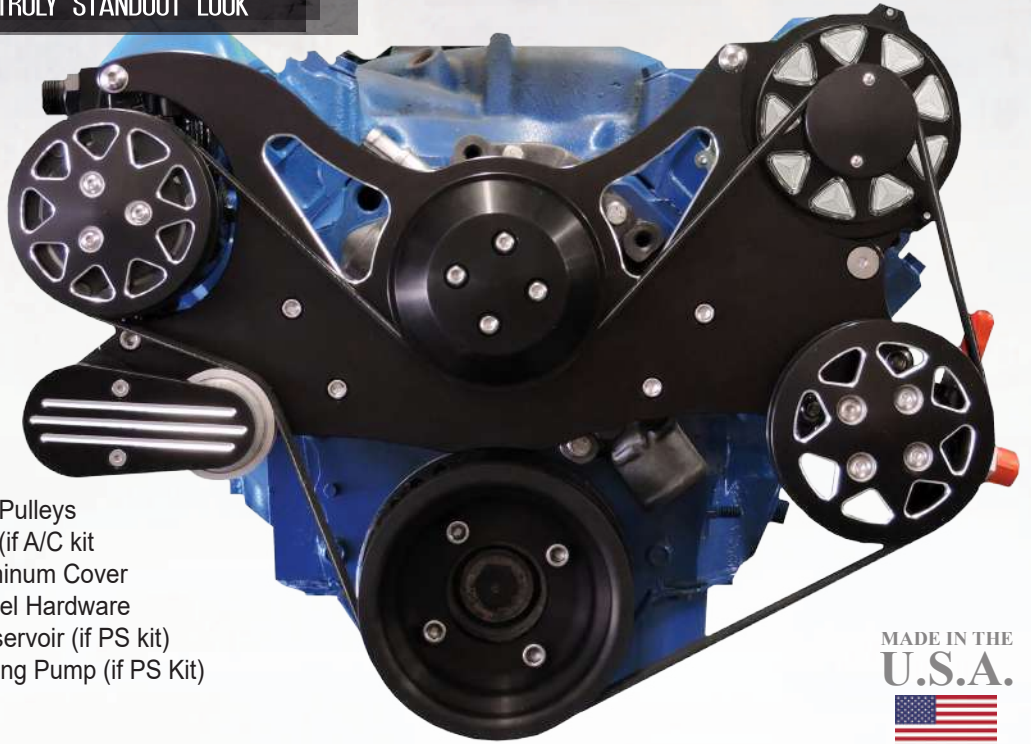

MADE IN THE
U.S.A.

Silverline Series - With A/C & With Power Steering
FDS-351-201

MACHINED 351 CLEVELAND

MACHINED KITS INCLUDE ALL COMPONENTS LISTED ABOVE (ACCESSORIES ARE CAST)



Machined - with A/C & With Power Steering
FDS-351-301

POLISHED SMALL BLOCK CHRYSLER

**Polished - With A/C
With Power Steering**
FDS-318-101

**Polished - With A/C
No Power Steering**
FDS-318-102

**Polished - No A/C
With Power Steering**
FDS-318-103

**Polished - No A/C
No Power Steering**
FDS-318-104

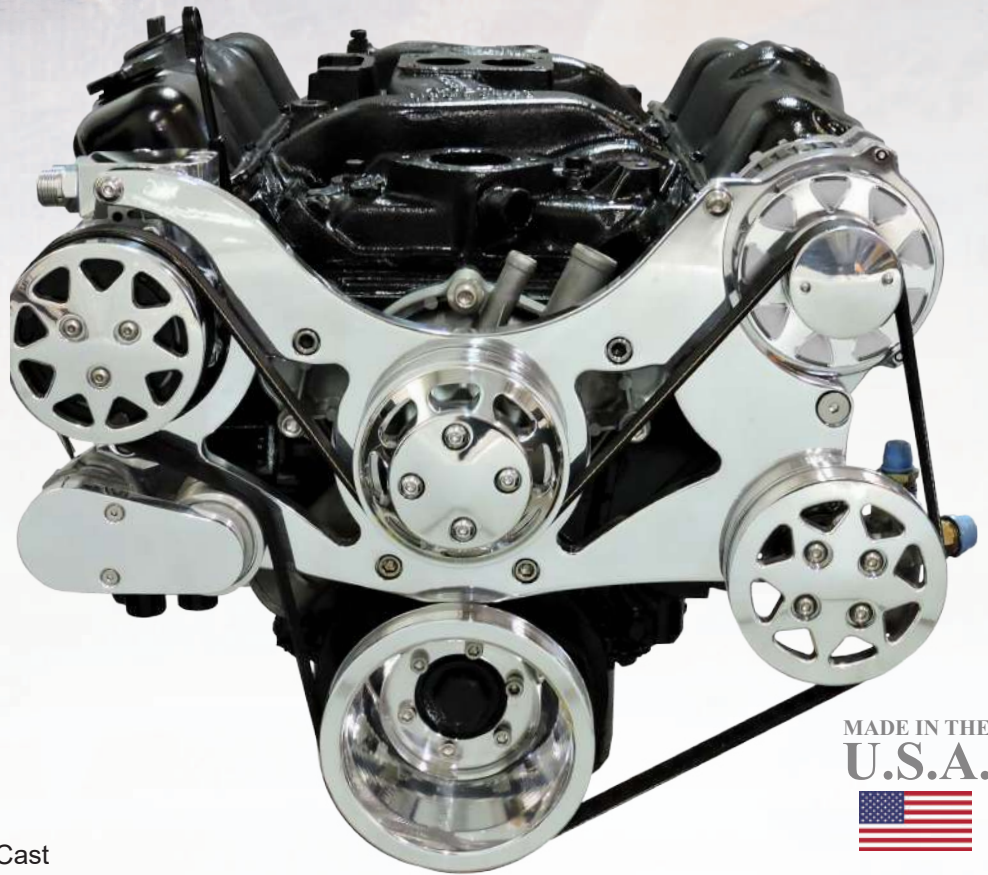

MADE IN THE
U.S.A.



KIT INCLUDES

Reverse Rotation Water Pump as Cast
Polished 160 Amp, 1 wire alternator
Polished Peanut Style A/C Compressor (if A/C kit)
Polished Aluminum Type II Power Steering Pump (if PS Kit)
Polished Power Steering Reservoir (if PS kit)
Tensioner with Polished Aluminum Cover
Polished 6061-T6 Aluminum Pulleys
Polished 6061-T6 Brackets
Gates 6-Groove Belt & Stainless Steel Hardware

From front of Block to front face of:

A/C Cover:	8"
Alt Pulley:	7.125"
Water Pump Pulley:	8.5"
Crank Pulley:	7.125"
PS Pulley:	7.5"

FITMENT NOTES:

Fits 1970-91 318/340/360 LA engines
Retains mechanical fuel pump

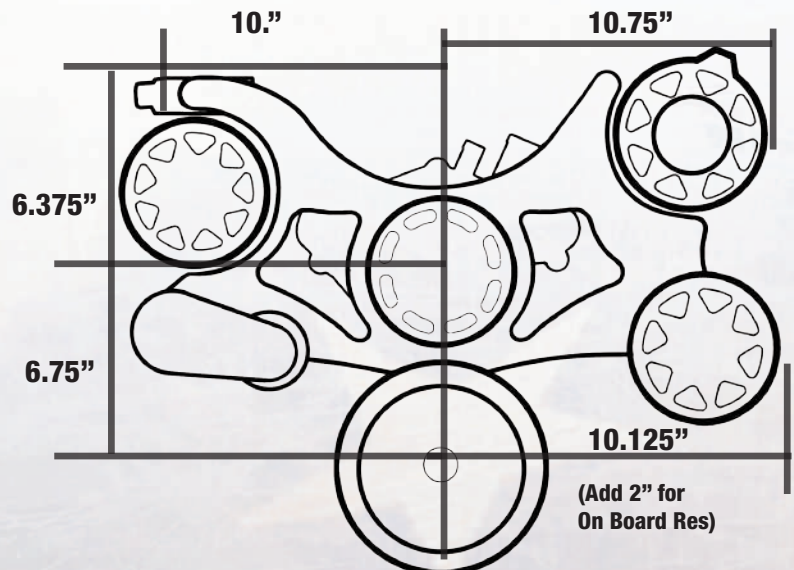

SILVERLINE SERIES SMALL BLOCK CHRYSLER

SILVERLINE SERIES KITS WERE DESIGNED TO GIVE ANY ENGINE THAT AGGRESSIVE BLACK STYLE HIGHLIGHTED BY MACHINED FINISHED AREAS FOR A TRULY STANDOUT LOOK

MADE IN THE
U.S.A.



KIT INCLUDES

Black 160 Amp, 1 wire alternator
6061-T6 Silverline Series Brackets
Reverse Rotation Water Pump as Cast
6061-T6 Silverline Series Aluminum Pulleys
Tensioner with Silverline Series Aluminum Cover
Gates 6-Groove Belt & Stainless Steel Hardware
Black Peanut Style A/C Compressor (if A/C kit)
Black Aluminum Type II Power Steering Pump (if PS Kit)
Silverline Series Power Steering Reservoir (if PS kit)



**Silverline Series - With A/C
With Power Steering**
FDS-318-201

**Silverline Series - With A/C
No Power Steering**
FDS-318-202

**Silverline Series - No A/C
With Power Steering**
FDS-318-203

**Silverline Series - No A/C
No Power Steering**
FDS-318-204

MACHINED SMALL BLOCK CHRYSLER

MACHINED KITS INCLUDE ALL COMPONENTS LISTED ABOVE (ACCESSORIES ARE CAST)



**Machined - With A/C
With Power Steering**
FDS-318-301

**Machined - With A/C
No Power Steering**
FDS-318-302

**Machined - No A/C
With Power Steering**
FDS-318-303

**Machined - No A/C
No Power Steering**
FDS-318-304

POLISHED BIG BLOCK CHRYSLER/HEMI

MADE IN THE
U.S.A.



KIT INCLUDES

Polished 6061-T6 Brackets
Polished 160 Amp, 1 wire alternator
Polished 6061-T6 Aluminum Pulleys
Polished Power Steering Reservoir
Polished Peanut Style A/C Compressor
Reverse Rotation Water Pump as Cast
Tensioner with Polished Aluminum Cover
Gates 6-Groove Belt & Stainless Steel Hardware
Polished aluminum Type II Power Steering Pump



Polished - With A/C & With Power Steering
FDS-440-101

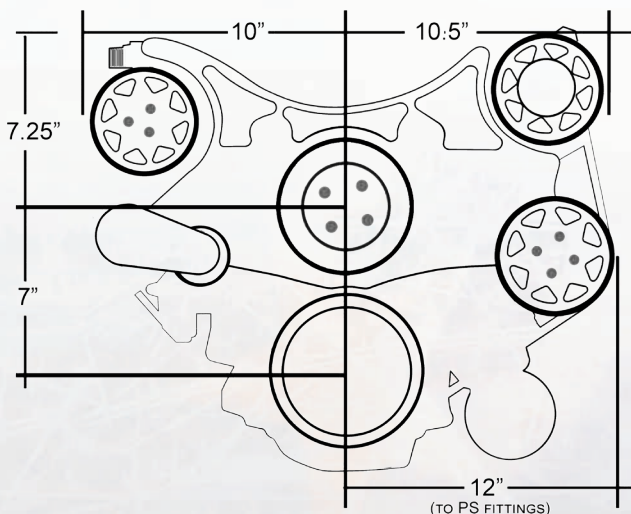

From front of Block to front face of:

A/C Cover:	5.75"
Alt Pulley:	6"
Water Pump Pulley:	7"
Crank Pulley:	4"
PS Pulley:	5.75"

FITMENT NOTES:

Fits 383/440 B and RB Big Blocks and 1966 and up 426 Hemi and 426, 472, 528 Hemi Crate Engines

SILVERLINE SERIES BIG BLOCK CHRYSLER/HEMI

SILVERLINE SERIES KITS WERE DESIGNED TO GIVE ANY ENGINE THAT AGGRESSIVE BLACK STYLE HIGHLIGHTED BY MACHINED FINISHED AREAS FOR A TRULY STANDOUT LOOK

KIT INCLUDES

Silverline Series 6061-T6 Brackets
Reverse Rotation Water Pump as Cast
Silverline Series 160 Amp, 1 wire alternator
Silverline Series 6061-T6 Aluminum Pulleys
Tensioner with Silverline Series Aluminum Cover
Gates 6-Groove Belt & Stainless Steel Hardware
Silverline Series Power Steering Reservoir
Silverline Series Peanut Style A/C Compressor
Silverline Series aluminum Type II Power Steering Pump

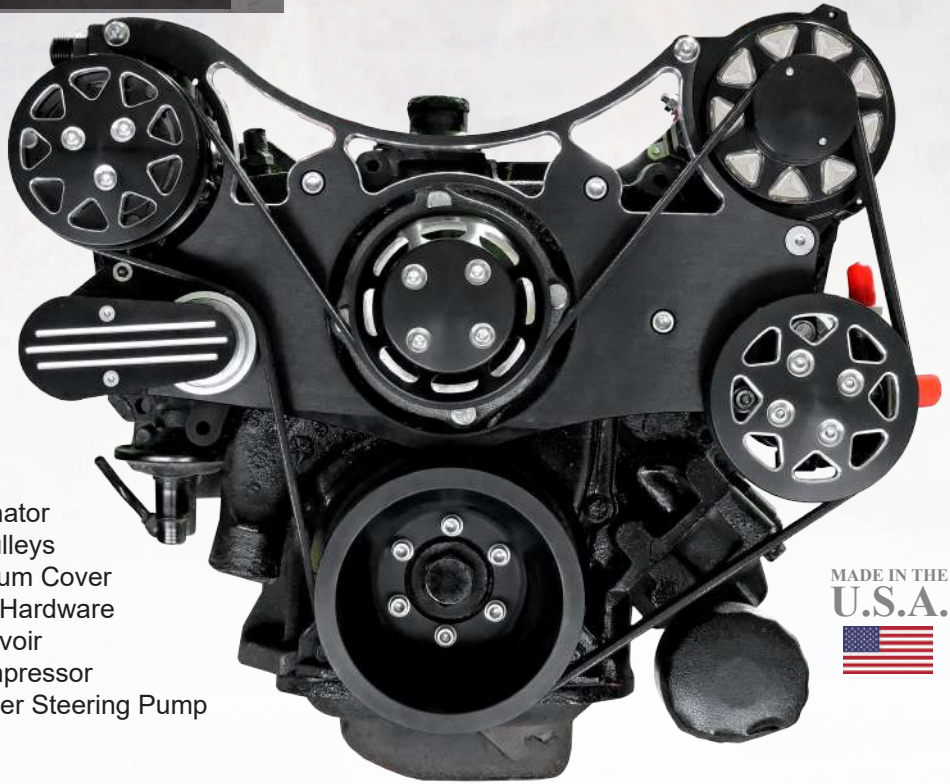

MADE IN THE
U.S.A.



Silverline Series - With A/C & With Power Steering
FDS-440-201

MACHINED BIG BLOCK CHRYSLER/HEMI

MACHINED KITS INCLUDE ALL COMPONENTS LISTED ABOVE (ACCESSORIES ARE CAST)



Machined - With A/C & With Power Steering
FDS-440-301

POLISHED HEMI 5.7 + 6.1

**Polished - With A/C
With Power Steering**
FDS-HEMI-101

MADE IN THE
U.S.A.

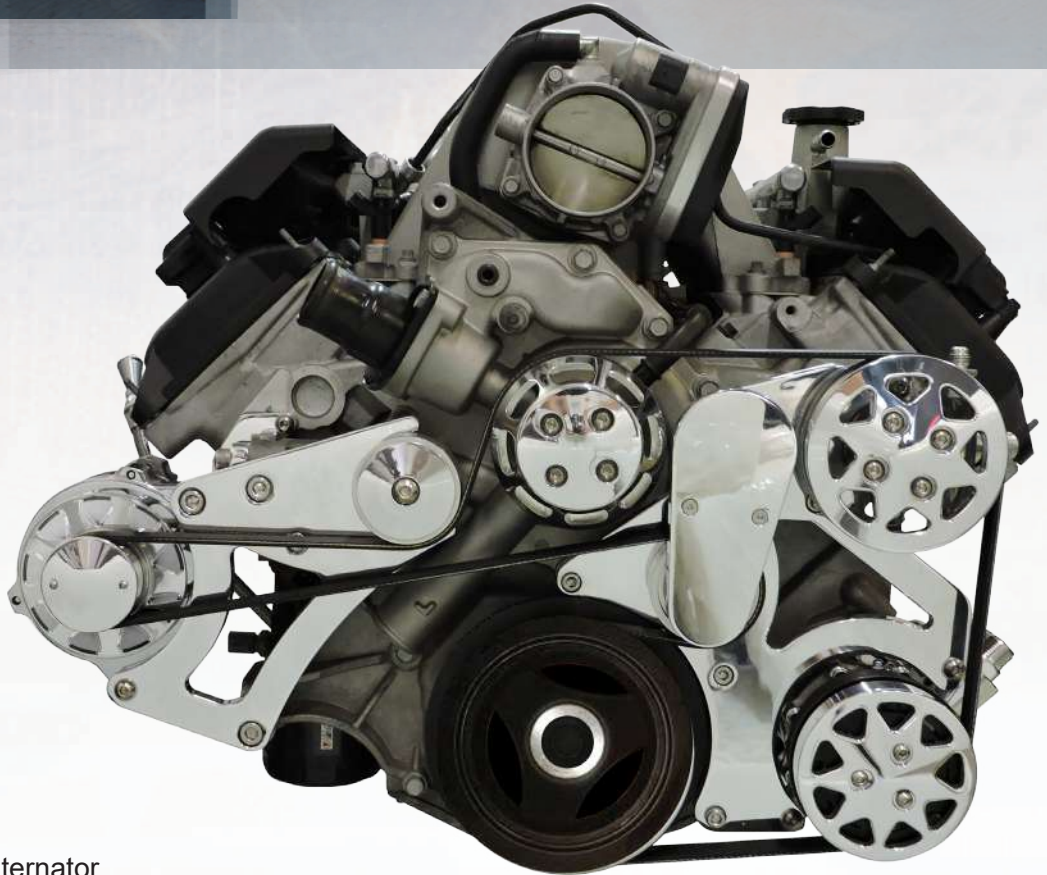

KIT INCLUDES

- Aluminum Water Pump
- Polished 6061-T6 Brackets
- Polished 160 Amp, 1 wire alternator
- Polished 6061-T6 Aluminum Pulleys
- Tensioner with Polished Aluminum Cover
- Gates 6-Groove Belt & Stainless Steel Hardware
- Polished Power Steering Reservoir
- Polished Peanut Style A/C Compressor
- Polished aluminum Type II Power Steering Pump

From front of Block to front face of:

A/C Cover:	6.75"
Alt Pulley:	5.625"
Water Pump Pulley:	6.625"
Crank Pulley:	5.75"
PS Pulley:	6"

FITMENT NOTES:

*Fits 2005-2014 5.7L/6.1L Hemi with car style timing cover
Includes EGR block off and gasket
ECM tuning required*

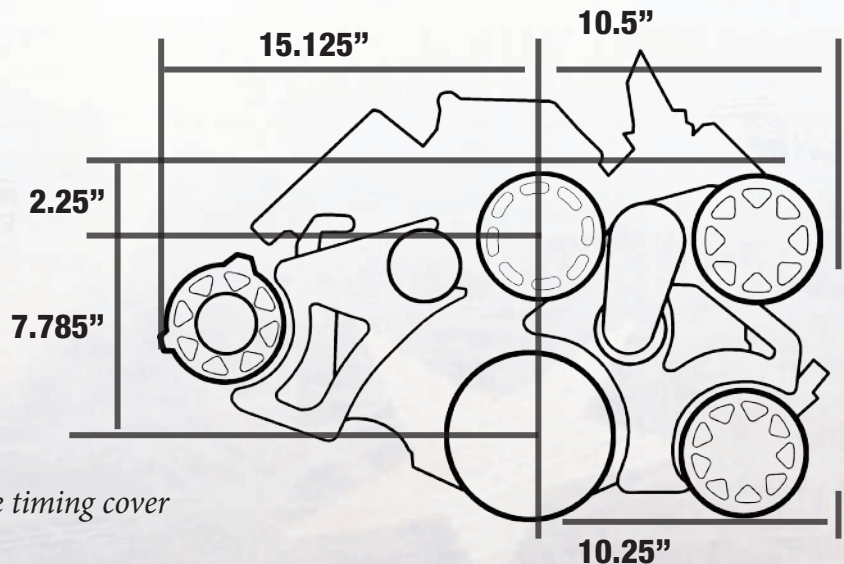

SILVERLINE SERIES HEMI 5.7 + 6.1

SILVERLINE SERIES KITS WERE DESIGNED TO GIVE ANY ENGINE THAT AGGRESSIVE BLACK STYLE HIGHLIGHTED BY MACHINED FINISHED AREAS FOR A TRULY STANDOUT LOOK

MADE IN THE
U.S.A.



Silverline Series - With A/C & With Power Steering

FDS-HEMI-201

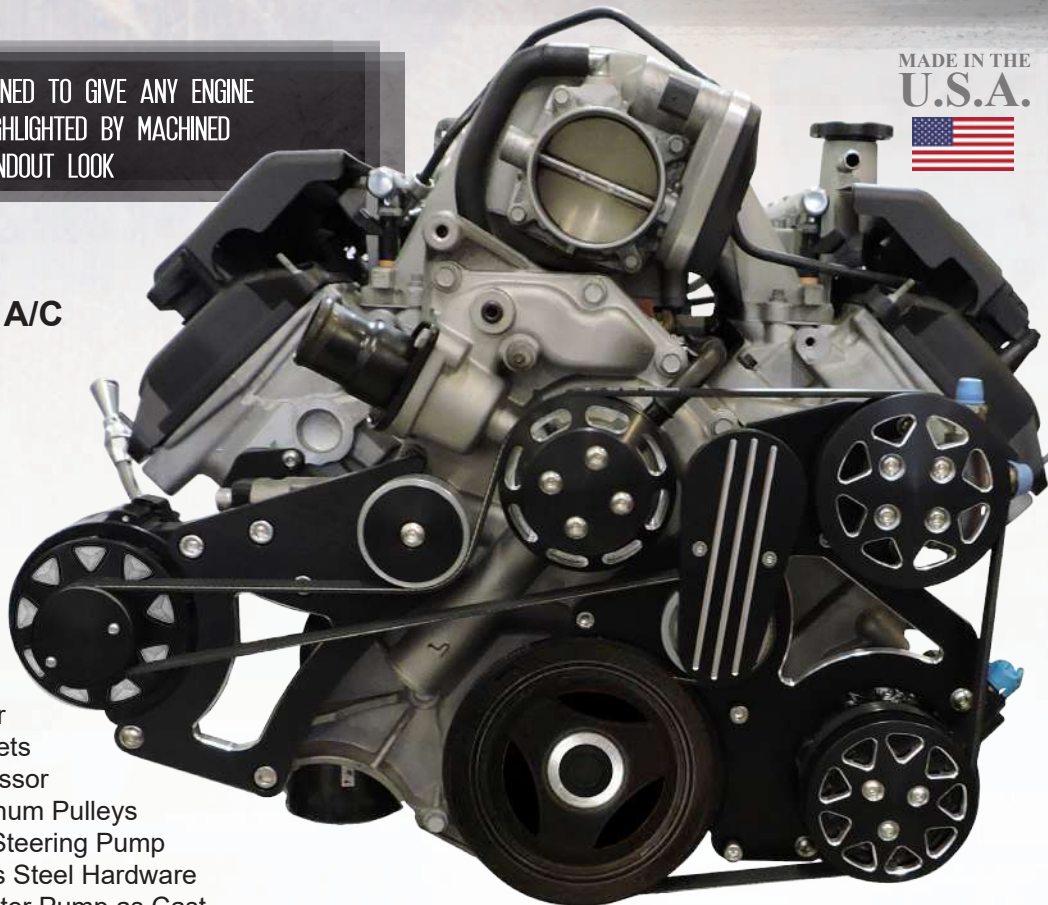

KIT INCLUDES

Black 160 Amp, 1 wire alternator
6061-T6 Silverline Series Brackets
Black Peanut Style A/C Compressor
6061-T6 Silverline Series Aluminum Pulleys
Black Aluminum Type II Power Steering Pump
Gates 6-Groove Belt & Stainless Steel Hardware
Aluminum Reverse Rotation Water Pump as Cast
Tensioner with Silverline Series Aluminum Cover
Silverline Series Remote Power Steering Reservoir

MACHINED HEMI 5.7 + 6.1

MACHINED KITS INCLUDE ALL COMPONENTS LISTED ABOVE (ACCESSORIES ARE CAST)



Machined - With A/C & With Power Steering
FDS-HEMI-301

BIG BLOCK CHEVY SUPERCHARGER

TAKE THE GUESS WORK OUT OF INSTALLING A SUPERCHARGER WITH OUR BOLT-ON KIT

Our kit includes the supercharger drive assembly, bypass valve, water pump, alternator, A/C compressor, power steering pump, belts, brackets, spacers, tensioners and hardware in one easy-to-install kit. Available in Polished, Silverline Series or Machined Finish.

KIT INCLUDES

- Bypass Valve
- Tensioners with Covers
- 6061-T6 Brackets
- Supercharger Drive Assembly
- Short Aluminum Water Pump as Cast
- 160 Amp, 1 wire alternator
- 6061-T6 Aluminum Pulleys
- Gates Serpentine Belts (6 & 10 Groove)
- Power Steering Reservoir
- Peanut Style A/C Compressor
- Aluminum Type II Power Steering Pump

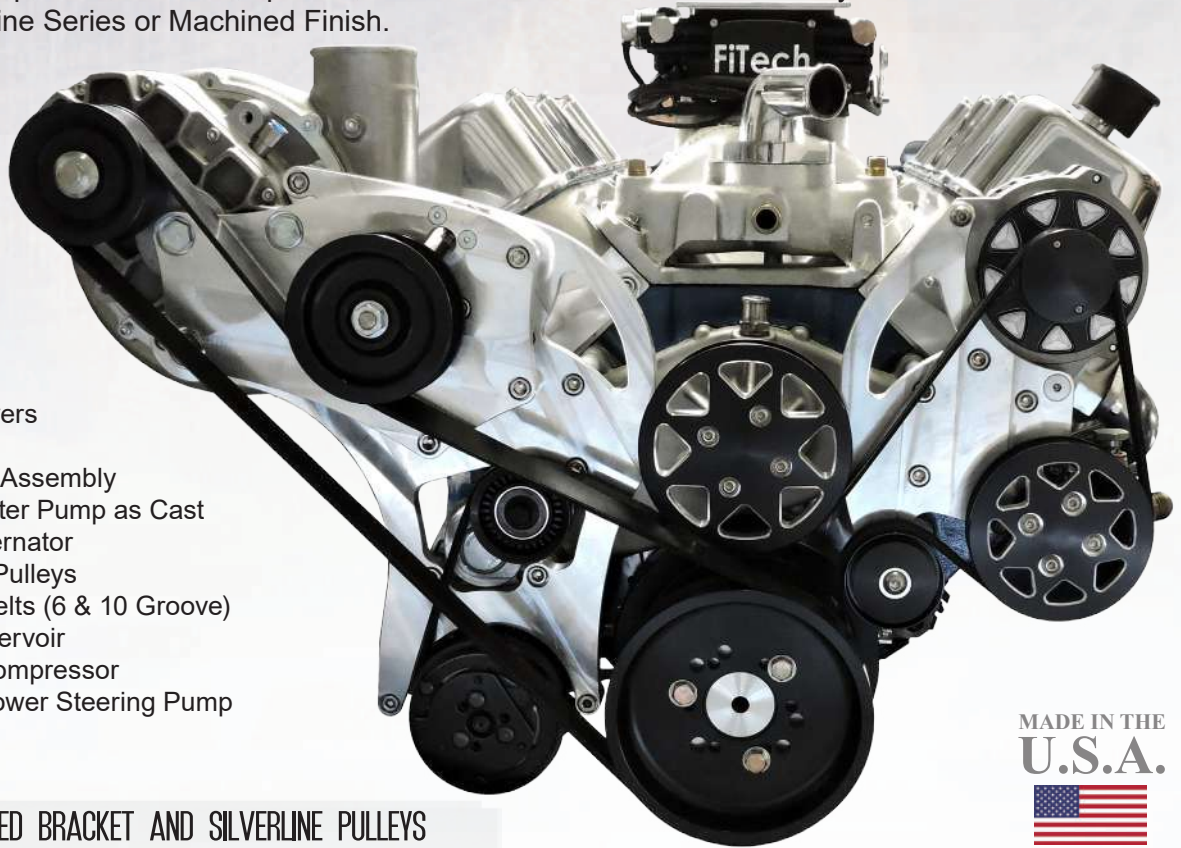

MADE IN THE
U.S.A.



SHOWN WITH MACHINED BRACKET AND SILVERLINE PULLEYS

FITMENT NOTES:

Currently not available with on-board reservoir

POLISHED

WITH A/C & POWER STEERING
FDS-BBCSC-101

SILVERLINE SERIES

WITH A/C & POWER STEERING
FDS-BBCSC-201

MACHINED

WITH A/C & POWER STEERING
FDS-BBCSC-301

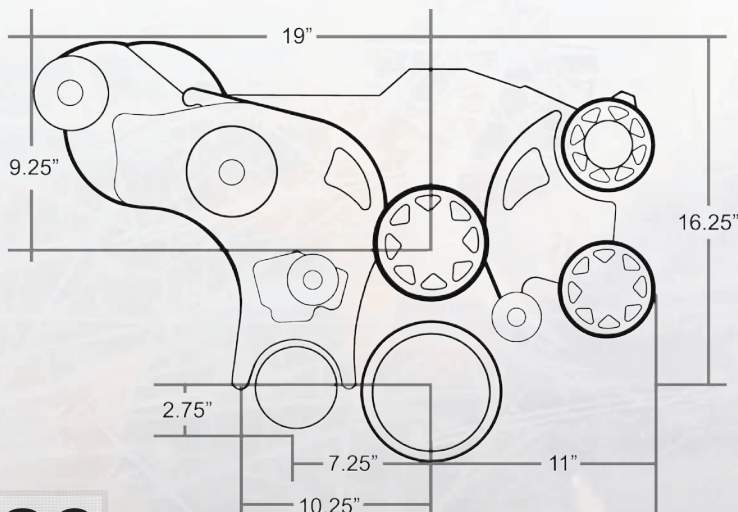

SMALL BLOCK CHEVY SERPENTINE CONVERSION KIT

ATTENTION: TO BE FITTED TO YOUR ENGINE, YOU MUST FIRST REMOVE THE WATER PUMP AND SERPENTINE BELT FROM YOUR ENGINE.

All American Billet Serpentine Conversion Kits are a great way to upgrade your front drive accessories and clean up your engine. Our kits convert V-belt pulleys to the modern 6-rib serpentine belts. They mount through the water pump for easy installation and are easily adjusted. Kits are designed for the long water pump and include alternator bracket (fits GM alternators with 6 o'clock and 12 o'clock mounting, 6.6" diameter, not included), Saginaw Style power steering pump (on PS kits, not included), pulleys (alternator fan pulley with cover, water pump pulley, crank pulley, and PS pulley (if PS kit), spacers, belts and hardware). Available in machined finish or polished.

POLISHED

POLISHED - ALTERNATOR AND POWER STEERING BRACKET KIT
SCK-SBC-103

POLISHED - ALTERNATOR BRACKET KIT
SCK-SBC-104

SILVERLINE SERIES

BLACK ANODIZED - ALTERNATOR AND POWER STEERING BRACKET KIT
SCK-SBC-703

BLACK ANODIZED - ALTERNATOR BRACKET KIT
SCK-SBC-704

MACHINED

MACHINED - ALTERNATOR AND POWER STEERING BRACKET KIT
SCK-SBC-303

MACHINED - ALTERNATOR BRACKET KIT
SCK-SBC-304

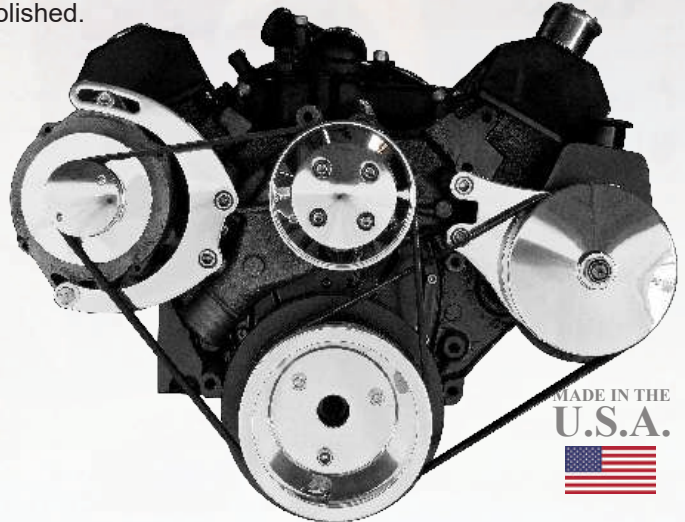

MADE IN THE U.S.A.

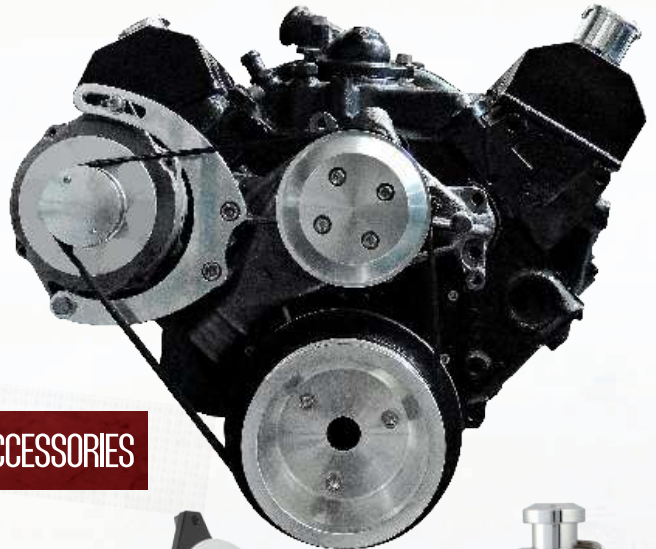
SMALL BLOCK CHEVY SERPENTINE CONVERSION KIT ACCESSORIES



4515NB6G
Sanden style AC compressor
508 R134 6 Groove pulley -
Polished



7935DP6G
GM Alternator KoolCharger 105 amp
1-wire or OEM 6 groove pulley -
Polished



7935FP6G
GM Alternator KoolCharger 160 amp
1-wire or OEM hookup 6 groove pulley
- Polished



6183A
GM PS Pump, Saginaw style
Chrome

4515NK6G
Sanden style AC compressor 508
R134 6 Groove pulley - Stealth
Black

7935-16G
GM Alternator KoolCharger 105 amp
Factory Cast PLUS+ 1-wire or OEM
6 groove pulley

7935K-16G
GM Alternator KoolCharger 160 amp
Factory Cast PLUS+ 1-wire or OEM
hookup 6 groove pulley

6183B
GM PS Pump, Saginaw style
Black

4515NC6G
Sanden style AC compressor 508
R134 6 Groove pulley -
FACTORY CAST PLUS+

7935E6G
GM Alternator KoolCharger 105 amp
1-wire or OEM 6 groove pulley -
Stealth Black

7935G6G
GM Alternator KoolCharger 160 amp
1-wire or OEM hookup 6 groove pulley
- Stealth Black

REVERSE ROTATION WATER PUMPS

Big Block Chevy Aluminum
As Cast 1495ACREV
Polished 1495ABREV

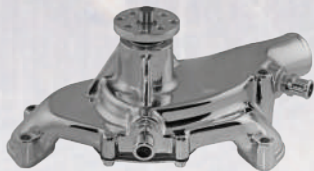

Small Block Chevy Aluminum
As Cast 1635N
Polished 1635ND



Big Block Ford Cast Iron 429/460 w/ Billet Impeller
As Cast 1470N



Chevy LS 1, 2, 3 & 6 Aluminum
As Cast 1310C
Polished 1310B



Small Block Ford Aluminum
As Cast CWP-645
Polished CWP-645-P



AIR CONDITIONING + ALTERNATORS

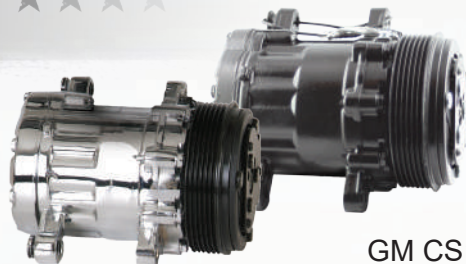

Peanut Style Air Conditioning Compressor
Utilizes R134A refrigerant - 6 Groove pulley

4517NC6G	As Cast
4517NB6G	Polished
4517NC6GB	Black

GM CS130 Style Alternators 160 AMP, 1-wire

7861M	As Cast
7861MP	Polished
7861MABLK	Black



fan not included but available upon request for additional charge.

AC HOSE KITS

Braided stainless steel A/C hose kit includes (1) #10 straight w/ service port, (1) #10 90 degree, (1) #8 straight w/ service port, (1) #8 45 degree, (3) #6 90 degree, and (1) #6 45 degree female o-ring fittings. ALL FITTINGS STAINLESS STEEL!
343120

Braided stainless steel A/C hose kit includes (2) #10 90 degree (1 w/ service port), (1) #8 90 degree w/ service port, (1) #8 45 degree, (3) #6 90 degree, and (1) #6 45 degree female o-ring fittings. ALL FITTINGS STAINLESS STEEL!
343100

HEATER HOSE KIT

Stock GM intake heater hose kit. Kit includes (2) #10 long drop 90 degree fittings, (1) 90 degree 1/2" NPT x -8 male AN and (1) straight 1/2" NPT x -8 male AN adapter. ALL FITTINGS STAINLESS STEEL!
343200



343120

POWER STEERING PUMPS + ACCESSORIES

ON-BOARD AND REMOTE RESERVOIRS REQUIRE DIFFERENT PS PUMPS

ON BOARD PUMPS



GM Type II - As Cast
Includes press on pulley hub
6175AL-1AB

GM Type II - Chrome
Includes press on pulley hub
6175ALP-1AB

GM Type II - Black Includes
press on pulley hub
6175ALB-1AB

REMOTE PUMPS



GM Type II - As Cast
Includes press on pulley hub
6175AL-2AB

GM Type II - Chrome
Includes press on pulley hub
6175ALP-2AB

GM Type II - Black
Includes press on pulley hub
6175ALB-2AB

PS FILTER

Universal In-Line PS Filter - 3/8" in-line,
dual action w/ internal magnet
5559



REMOTE PS RESERVOIRS

All American Billet power steering reservoirs are machined from 6061-T6 billet aluminum and come in machined, "Silverline", black anodized and polished finishes. Includes reservoir, bracket and mounting hardware.

- PSR-P Power Steering Reservoir Polished
- PSR-SL Power Steering Reservoir "Silverline"
- PSR-M Power Steering Reservoir Machined
- PSR-B Power Steering Reservoir Black Anodized



ON BOARD PS RESERVOIR

FOR ON-BOARD RESERVOIR - 1) On Board Power Steering Pump 2) Field Attachable Banjo Fitting 3) Banjo Bolt 4) (optional) Power Steering Hose Kit (Below)



6175ARES

Type II Plastic On-Board Reservoir
with Cap & Mounting Clips

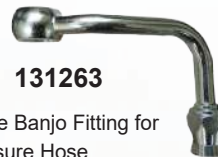

131263

Field Attachable Banjo Fitting for
-6 Teflon Pressure Hose



131362

Banjo Bolt & Sealing Washers for 5/8-18
or 16mm-1.5mm Thread Pitch

POWER STEERING HOSE KITS

1 piece cast aluminum Ford rack to GM pump

131101

'65-'79 GM gearbox to GM pump

131151

1980 & Later GM rack or gear box to GM pump

131171

Remote Reservoir Hose Kit w/ 3/8" pipe return hose/fitting

131106

(Not Pictured)

- 1) Power Steering Hose Kit
- 2) Remote Reservoir Hose Kit w/ 3/8" pipe return hose/fitting
- 3) 90 Degree Fitting are needed to complete steering plumbing.
- 4) (optional) Mustang II Low Pressure Fitting

131101

or

131151

or

131171



Too much flow in the power steering system can cause a "twitchy" feeling and also cavitation issues. If you are using our FDS with a Mustang II style rack and pinion, GM G Body steering boxes and some aftermarket steering boxes, you need a flow control valve. (**Mustang II Low Pressure Fitting**) This fitting will reduce flow from 3 GPM to approximately 2 GPM



90 Degree Fitting
131910



Mustang II Low Pressure Fitting
For use with Mustang II rack & pinion
131199

BILLET L83/L86 PS BRACKET FOR KRC PS PUMP

Chevy/GM Gen. V engine swaps are becoming very popular. You now have an easy solution for adding a KRC PS3 power steering pump to your swap with this All American Billet bracket. Made from 6061-T6 aluminum and includes stainless steel mounting hardware. Available in Machined or Polished finish. **Note: Power steering pump sold separately through KRC.**



PSBL83 Machined
PSBL83-P Polished

BILLET L83/L86 PS BRACKET + PULLEY FOR GM II PUMP



Chevy/GM Gen. V engine swaps are becoming very popular. We're now offering a Billet L83/L86 PS Bracket and Pulley for the GM Type II PS Pump. You now have a simple solution for adding a gm type II power steering pump to your swap with this All American Billet bracket. Made from 6061-T6 aluminum and includes stainless steel mounting hardware. Available in Machined or Polished finishes. **Power steering pump sold separately.**

PSBL83-II Machined
PSBL83-II-P Polished

RADIATOR OVERFLOW TANKS

All American Billet radiator overflow tanks were designed to match the unique design of our power steering remote reservoirs. They are machined from 6061-T6 billet aluminum and come in polished, "Silverline", or machined finish. Includes tank, (2) brackets and mounting hardware.



ROFT-10 10", Machine Finish
ROFT-12 12", Machine Finish
ROFT-14 14", Machine Finish

ROFT-10-P 10", Polished
ROFT-12-P 12", Polished
ROFT-14-P 14", Polished

ROFT-10-SL 10", Silverline
ROFT-12-SL 12", Silverline
ROFT-14-SL 14", Silverline

ROFT-10-B 10" Black Anodized
ROFT-12-B 12" Black Anodized
ROFT-14-B 14" Black Anodized

10" HOLDS 16oz

12" HOLDS 20oz

14" HOLDS 24oz

All American Billet air cleaner nuts are machined from 6061-T6 billet aluminum and come in 3 styles: Standard, 1" diameter bullet and the 1.25" diameter bullet for that aggressive 2" tall stance. Thread pitch is 1/4-20 and they are available in machined finish, polished and our exclusive "Silverline Series"

AIR CLEANER NUTS

ACNB100 Air Cleaner Nut - Bullet 1" dia., Machine Finish
ACNB100-P Air Cleaner Nut - Bullet 1" dia., Polished
ACNB125 Air Cleaner Nut - Bullet 1.25" dia., Machine Finish
ACNB125-P Air Cleaner Nut - Bullet 1.25" dia., Polished
ACNB100-BG Air Cleaner Nut - Bullet 1" dia. "Silverline Series"
ACNB125-BG Air Cleaner Nut - Bullet 1.25" dia "Silverline Series"



AC/HEATER BULKHEADS

All American Billet A/C and heat bulkheads are made from 6061-T6 aluminum and come in highly polished, "Silverline" or machined finish. Fittings included are #6 x 5/8-18; #8 x 3/4-16; and #10 x 7/8-14.

Includes (2) #8 fittings

- 4100 Heat bulkhead, 2 fitting oval, Machined finish
- 4100-P Heat bulkhead, 2 fitting oval, Polished
- 4100-SL Heat bulkhead, 2 fitting oval, "Silverline"



4100

Includes (1) #6 and (1) #10 fitting

- 4101 A/C bulkhead, 2 fitting oval, Machined finish
- 4101-P A/C bulkhead, 2 fitting oval, Polished
- 4101-SL A/C bulkhead, 2 fitting oval, "Silverline"



4101

Includes (1) #6 and (1) #10 fitting and (2) #8 fittings

- 4102 A/C & heat, 4 fitting inline, Machined finish
- 4102-P A/C & heat, 4 fitting inline, Polished
- 4102-SL A/C & heat, 4 fitting inline, "Silverline"
- 4103 A/C & heat, 4 fitting square/oval, Machined finish
- 4103-P A/C & heat, 4 fitting square/oval, Polished
- 4103-SL A/C & heat, 4 fitting square/oval, "Silverline"
- 4104 A/C & heat, 4 fitting square pointed, Machined finish
- 4104-P A/C & heat, 4 fitting square pointed, Polished
- 4104-SL A/C & heat, 4 fitting square pointed, "Silverline"
- 4105 A/C & heat, 4 fitting flat oval, Machined finish
- 4105-P A/C & heat, 4 fitting flat oval, Polished
- 4105-SL A/C & heat, 4 fitting flat oval, "Silverline"
- 4106 A/C & heat, 4 fitting triangle, Machined finish
- 4106-P A/C & heat, 4 fitting triangle, Polished
- 4106-SL A/C & heat, 4 fitting triangle, "Silverline"
- 4107 A/C & heat, 4 fitting triangle oval, Machined finish
- 4107-P A/C & heat, 4 fitting triangle oval, Polished
- 4107-SL A/C & heat, 4 fitting triangle oval, "Silverline"



4102

Includes (1) #6 and (1) #10 fitting

- 4108 A/C bulkhead, 2 fitting inline, Machined finish
- 4108-P A/C bulkhead, 2 fitting inline, Polished
- 4108-SL A/C bulkhead, 2 fitting inline, "Silverline"



4103

Includes (2) #8 fittings

- 4109 Heat bulkhead, 2 fitting inline, Machined finish
- 4109-P Heat bulkhead, 2 fitting inline, Polished
- 4109-SL Heat bulkhead, 2 fitting inline, "Silverline"



4104



4105



4106



4107



4108



4109

LS TO SMALL BLOCK CHEVY CONVERSION KIT



Our Billet LS-to-Small Block Chevy valve cover adapters are designed to hide the ugly coil packs with Small Block Chevy valve covers. They work with 4 different coils (GM 12573190, 12558948, 12611424 and AC Delco D514A) and come with coil mounting hardware, oil plugs and PCV fittings. Uses stock valve cover hardware. Gaskets and valve covers not included. Sold in pairs.

NOTE - These conversions will NOT work with our LSA or LSX based kits. The alternator and AC will hit the valve covers.

LS-SBC-VCC

OIL BREATHERS

All American Billet oil breathers are machined from 6061-T6 billet aluminum and are polished to a mirror finish or available in our exclusive "Silverline" series. Available in ribbed or ball milled design.



BALL MILLED



RIBBED



STANDARD

- BOR-P Breather, Oil, Ribbed - Polished
- BOBM-P Breather, Oil, Ball Milled - Polished
- BOR-BG Breather, Oil, Ribbed **"Silverline Series"**
- BOBM-BG Breather, Oil, Ball Milled **"Silverline Series"**

WITH REPLACEABLE PCV VALVE

- BOR-PCV-P Breather, Oil, PCV Ribbed - Polished
- BOBM-PCV-P Breather, Oil, PCV Ball Milled - Polished
- BOR-PCV-BG Breather, Oil, PCV Ribbed **"Silverline Series"**
- BOBM-PCV-BG Breather, Oil, PCV Ball Milled **"Silverline Series"**



MANUFACTURED IN PHOENIX, ARIZONA

SPARK PLUG WIRE LOOMS



MACHINED IN PHOENIX, AZ



Machined from 6061-T6 aluminum, these Spark Plug Wire Looms will dress up any engine compartment. Designed for 8 & 8.5mm wires. Comes with adjustable brackets and hardware. *(Does not fit GM center bolt cylinder heads)* Sold in pairs.

- SPWL Spark Plug Wire Loom - Machined
- SPWL-P Spark Plug Wire Loom - Polished
- SPWL-B Spark Plug Wire Loom - Black Anodized
- SPWL-SL Spark Plug Wire Loom - "Silverline Series"



SPARK PLUG WIRE SEPARATORS

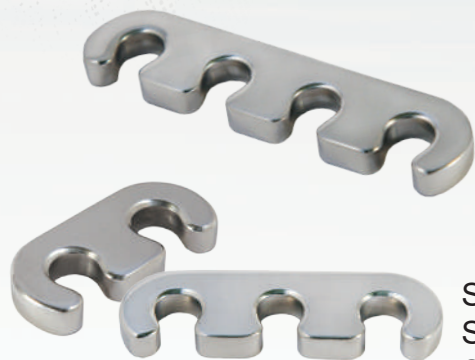

All American Billet spark plug wire separators are machined from 6061-T6 billet aluminum and are polished to a mirror finish. Sold individually to meet your needs. Fits 8 and 8.5 MM wires.

- SPWS2-P Spark Plug Wire Separators, 2 Wire, Polished
- SPWS3-P Spark Plug Wire Separators, 3 Wire, Polished
- SPWS4-P Spark Plug Wire Separators, 4 Wire, Polished

FUEL BLOCK OFFS

All American Billet fuel block off covers are machined from 6061-T6 billet aluminum and are polished to a mirror finish. Available in plain or ball milled design.

- FBOBBC-P Fuel Block Off, Big Block Chevy, Plain, Polished
- FBOBBCBM-P Fuel Block Off, Big Block Chevy, Ball Milled, Polished
- FBOBBC-BG Fuel Block Off, Big Block Chevy, "Silverline Series"
- FBOFORD-P Fuel Block Off, Ford, Plain, Polished
- FBOFORDBM-P Fuel Block Off, Ford, Ball Milled, Polished
- FBOFORD-BG Fuel Block Off, Ford, "Silverline Series"



[COMPACT DESIGN]

BILLET INTERIOR DOOR HANDLES + WINDOW CRANKS

High quality, American Made and machined from 6061-T6 Aluminum, these handles will dress up any interior. Three highly polished styles to choose from: Ball Milled; Single Cutout and Dual Cutout. Steel inserts with 3 set screws for adjustable installation.



DOOR HANDLES

- DH-BM-P Door Handle - Ball Milled - Polished (pr)
- DH-SC-P Door Handle - Single Cutout - Polished (pr)
- DH-DC-P Door Handle - Dual Cutout - Polished (pr)

WINDOW CRANKS

- WC-BM-P Window Crank - Ball Milled - Polished (pr)
- WC-SC-P Window Crank - Single Cutout - Polished (pr)
- WC-DC-P Window Crank - Dual Cutout - Polished (pr)

HOTRODS &
CLASSIC TRUCKS &



DOOR HANDLES

- DH-BM-BG Door Handle - Ball Milled - "Silverline Series" (pr)
- DH-SC-BG Door Handle - Single Cutout - "Silverline Series" (pr)
- DH-DC-BG Door Handle - Dual Cutout - "Silverline Series" (pr)

WINDOW CRANKS

- WC-BM-BG Window Crank - Ball Milled - "Silverline Series" (pr)
- WC-SC-BG Window Crank - Single Cutout - "Silverline Series" (pr)
- WC-DC-BG Window Crank - Dual Cutout - "Silverline Series" (pr)

BILLET SHORT WINDOW CRANKS



High quality, American Made and machined from 6061-T6 Aluminum, these handles will dress up any interior. Three styles to choose from: Ball Milled; Single Cutout; and Dual Cutout. Steel inserts with 3 set screws for adjustable installation. Measure 3.25" long.



SHORT WINDOW CRANKS

- WCS-BM-P Short Window Crank - Ball Milled, Polished (pr)
- WCS-SC-P Short Window Crank - Single Cutout, Polished (pr)
- WCS-DC-P Short Window Crank - Dual Cutout, Polished (pr)



SILVERLINE SHORT WINDOW CRANKS

- WCS-BM-SL Short Window Crank - Ball Milled, Silverline (pr)
- WCS-SC-SL Short Window Crank - Single Cutout, Silverline (pr)
- WCS-DC-SL Short Window Crank - Dual Cutout, Silverline (pr)

FITMENT NOTES FOR ALL HANDLES

ALL AMERICAN BILLET DOOR HANDLES AND WINDOW CRANKS ARE MANUFACTURED WITH HIGH QUALITY STEEL INSERTS AND ARE ENGINEERED WITH 3 BLACK OXIDIZED SET SCREWS FOR MAXIMUM STRENGTH AND DURABILITY. WHEN ORDERING YOUR WINDOW CRANKS/DOOR HANDLES PLEASE SPECIFY WHICH INSERT IS NEEDED FOR INSTALLATION AS WE OFFER 3 UNIQUE FITMENTS.



GM up to 1948
(7/16" round spline)
Add a (-1) to part #

Example: **WC-DC-BG-1**



GM/Ford 1949 and Later
(1/2" round spline)
Add (-2) to part #

Example: **WC-DC-BG-2**



Ford cars to 1948 + Ford Trucks to 1952
(3/8" square spline)
Add (-3) to part #

Example: **WC-DC-BG-3**

DIMMER SWITCH COVERS



ALWAYS APPROVING

High quality, American Made and machined from 6061-T6 Aluminum, these covers dress up the stock dimmer switch. Easy installation and removal for show or driving. Comes with set screw. Inside diameter is approx. 13/16".

- DSC Dimmer Switch Cover - Machined Finish
- DSC-P Dimmer Switch Cover - Polished
- DSC-B Dimmer Switch Cover - Black Anodized
- DSC-BG Dimmer Switch Cover - "Silverline"
- DSCR Dimmer Switch Cover, Ribbed - Machined Finish
- DSCR-P Dimmer Switch Cover, Ribbed - Polished
- DSCR-B Dimmer Switch Cover, Ribbed - Black Anodized
- DSCR-BG Dimmer Switch Cover, Ribbed - "Silverline"



DASH KNOBS

Machined from 6061 aluminum these dash knobs come in polished, "Silverline" and machined finish. Short shaft is 1/4" and long shafts are 7/16" and fit 11/64" rod. Set screw included.

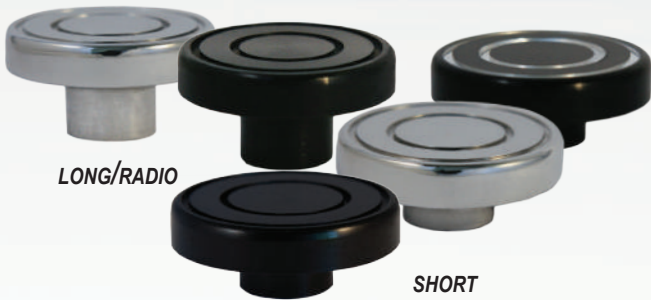

SHORT 67-72

- DKS Dash Knob - Short - Machined
- DKS-P Dash Knob - Short - Polished
- DKS-B Dash Knob - Short - Black Anodized

LONG 67-72

- DKL Dash Knob - Long - Machined
- DKL-P Dash Knob - Long - Polished
- DKL-B Dash Knob - Long - Black Anodized
- DKL-BG Dash Knob - Long - "Silverline Series"

RADIO 67-72

- DKR Dash Knob - Radio - Machined
- DKR-P Dash Knob - Radio - Polished
- DKR-B Dash Knob - Radio - Black Anodized
- DKR-BG Dash Knob - Radio - "Silverline Series"

UNIVERSAL 1/4" INSIDE DIAMETER

- DKZ25 Dash Knob - Long - Machined
- DKZ25-P Dash Knob - Long - Polished
- DKZ25-B Dash Knob - Long - Black Anodized
- DKZ25-SL Dash Knob - Long - "Silverline Series"

BILLET DOOR PULL STRAP COVERS

'81-'91 Silverado/Sierra. Replace your cheap plastic broken covers once and for all! Made from 6061-T6 billet aluminum. (Requires 4)

- DPSC81-91SS-P Polished
- DPSC81-91SS-B Black

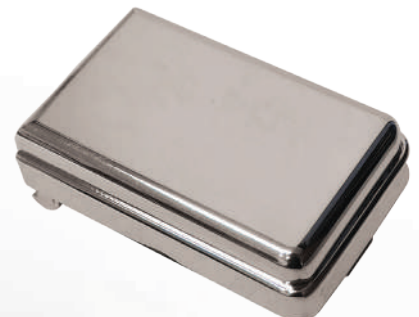

VISOR CLIPS

All American Billet Visor Hooks are machined from 6061-T6 aluminum, these hooks are made to last and look great. No more cracked, faded or broken visor hooks. Available for '67-'72 Chevy trucks.

- VH01 Visor Hook, (pr) - Machine Finish
- VH01-P Visor Hook, (pr) - Polished
- VH01-B Visor Hook, (pr) - Black Anodized



★★★ EMERGENCY BRAKE HANDLES

Machined from 6061-T6 Aluminum our Emergency Brake Release Handles are made to last and look great. No more cracked, faded or broken handles. Available in Machined, Polished, Black Anodized and "Silverline Series"

Available for:
 69-'74 Chevy/GMC trucks 1968-1972 Chevrolet Full Size Passenger Cars
 1967-1981 Camaro 1968-1972 Chevy El Camino
 1968-1974 Nova *(or any application that requires a 1/4-20" thread.)*

- HEB Emergency Brake Handle
- HEB-B Emergency Brake Handle - Black Anodized
- HEB-P Emergency Brake Handle - Polished
- HEB-SL Emergency Brake Handle - "BRAKE RELEASE"



Available for: 73-87' Chevy/GMC Trucks

- HEB7387 Emergency Brake Handle - Machined
- HEB7387-B Emergency Brake Handle - Black Anodized
- HEB7387-P Emergency Brake Handle - Polished
- HEB7387-SL Emergency Brake Handle - "BRAKE RELEASE"



BILLET FORD ASH TRAY HANDLES

'68-'72 Trucks. Replace your cheap plastic broken knob once and for all! Made from 6061-T6 billet aluminum and available in machined finish, polished, or black anodized.

- HFAT68-72T Machine Finish
- HFAT68-72T-P Polished
- HFAT68-72T-B Black Anodized

BILLET CHEVY ASH TRAY HANDLES



64-66 Chevy Trucks

- HAT-6466-C10 Machine Finish
- HAT-6466-C10-P Polished
- HAT-6466-C10-B Black Anodized

- HAT-6063-C10 Machine Finish
- HAT-6063-C10-P Polished
- HAT-6063-C10-B Black Anodized



60-63 Chevy Trucks

BILLET SHIFT KNOBS

Machined from 6061-T6 Aluminum, these Shift Knobs are made to last and look great. No more cracked, faded or broken knobs. Available for '67 – '72 Chevy trucks or any application that has a 5/16" diameter. Set screw included.

ROUND HEAD

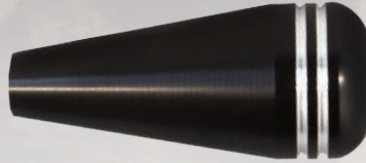
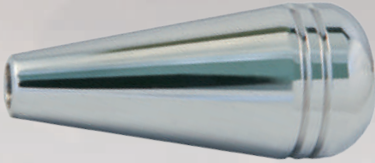

- SKRH Shift Knob - Round Head
- SKRH-B Shift Knob - Round Head - Black Anodized
- SKRH-P Shift Knob - Round Head - Polished
- SKRH-BG Shift Knob - Round Head **"Silverline Series"**

FLAT HEAD

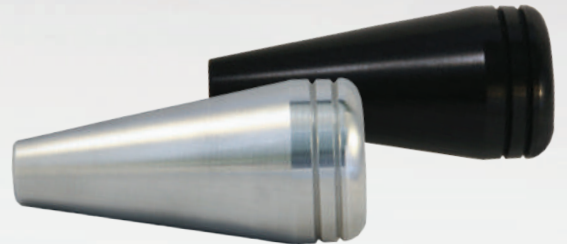
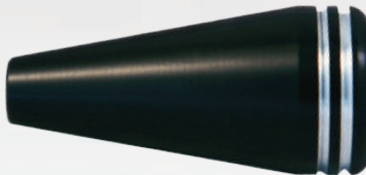
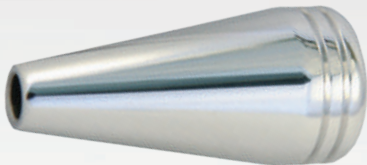

- SKFH Shift Knob - Flat Head
- SKFH-B Shift Knob - Flat Head - Black Anodized
- SKFH-P Shift Knob - Flat Head - Polished
- SKFH-BG Shift Knob - Flat Head **"Silverline Series"**

SMALL SHIFT KNOBS

Machined from 6061-T6 Aluminum, these Shift Knobs have a smaller profile and are made to last and look great. No more cracked, faded or broken knobs. Available for '67 – '72 Chevy trucks or any application that has a 5/16" diameter. Set screw included.

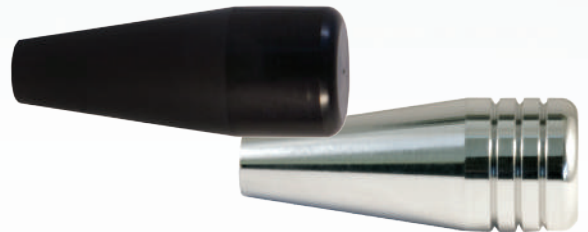

- SKS Shift Knob - Small- Machine Finish
- SKS-P Shift Knob - Small- Polished
- SKS-B Shift Knob - Small- Black Anodized
- SKS-BG Shift Knob - Small **"Silverline Series"**

THE SMOOTH, COOL FEEL OF A BILLET SHIFT HANDLE



BILLET SHIFT HANDLES

Machined from 6061-T6 Aluminum, these Shift handles are made to last and look great. Available in machine finish, polished, black anodized and "Silverline Series". Shift Knob is included.

FITMENT NOTES: AVAILABLE FOR VARIOUS MODELS/YEARS. PLEASE SPECIFY FITMENT:

- 1** '67 - '72 Chevy trucks
- 2** '73 - '94 GM vehicles
- 3** 99-06 Chevy/GMC Fullsize Trucks
98-05 Chevy/GMC S-10, Sonoma, Blazer, Jimmy, Astro, Safari



- SH Shift Handle - Machine Finish
- SH-P Shift Handle - Polished
- SH-BG Shift Handle "**Silverline Series**"

3 PIECE COLUMN KIT FOR '67-72 GM TRUCKS

This 3 piece billet kit includes the turn signal lever, tilt wheel lever, and emergency flasher knob. Perfect compliment for our already popular billet shift knobs. Available in machined finish, polished, or our exclusive Silverline Series.



3 PC KIT:

- CKCT 3-piece Column Kit, Machined
- CKCT-P 3-piece Column Kit, Polished
- CKCT-SL 3-piece Column Kit, "**Silverline Series**"

TURN SIGNAL HANDLE ONLY

- TSH Turn Signal Handle, Machined
- TSH-P Turn Signal Handle, Polished
- TSH-SL Turn Signal Handle, "**Silverline Series**"



BILLET CUP HOLDERS

Our award winning cup holders are designed to be installed in the dash or under the dash. Simply push in and the spring loaded cup holder ejects and is ready to be used.

When not being used, it is simply pushed back in and is out of the way. Made from 6061-T6 billet aluminum and available in machine finish, polished and black. Cup hole is 3" diameter.

48200-P

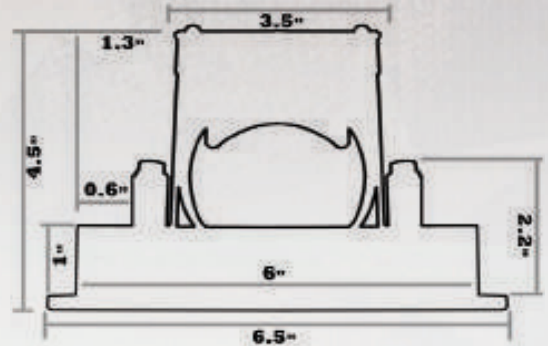

48200-B



3 TIME WINNER
SEMA GLOBAL MEDIA AWARDS **MEMBER**

- 48200
- 48200-P
- 48200-B

- Cup Holder, Under Dash, Machine finish
- Cup Holder, Under Dash, Polished Face
- Cup Holder, Under Dash, Black Face





★ DOOR LOCK KNOBS

Machined from 6061-T6 aluminum, these door lock knobs are made to last and look great. No more cracked, faded or broken knobs. Available for '67 - '72 Chevy trucks or any application that requires a 10-24 thread. Sold in pairs.



STEPPED



ROUND HEAD



DLKS
DLKS-B
DLKS-P

Door Lock Knobs - Stepped
Door Lock Knobs - Stepped - Black Anodized
Door Lock Knobs - Stepped - Polished

DLKRH
DLKRH-B
DLKRH-P
DLKRH-BG

Door Lock Knobs - Round Head
Door Lock Knobs - Round Head - Black Anodized
Door Lock Knobs - Round Head - Polished
Door Lock Knobs - Round Head - **"Silverline Series"**

CLASSIC



DLK
DLK-B
DLK-G
DLK-PG
DLK-P
DLK-BG

Door Lock Knobs
Door Lock Knobs - Black Anodized
Door Lock Knobs - Machine finish w/ Grooves
Door Lock Knobs - Polished w/ Grooves
Door Lock Knobs - Polished
Door Lock Knobs **"Silverline Series"**

STEERING WHEELS AND MORE

14" Flat Billet Steering Wheels - Wrap Your Own

These billet steering wheels are made from 6061-T6 billet aluminum and designed to be custom finished in leather wrap, paint or whatever you desire.

Available in Classic 3 hole per spoke or Banjo Style in machine finish or polished.



Call for wrap information
(wrap **not** included)

Machined
Polished



3-HOLE

- 4501-3 Steering Wheel, Aluminum Wrap-your-own Flat 14" Classic, Machine finish
- 4501-3-P Steering Wheel, Aluminum Wrap-your-own Flat 14" Classic, Polished
- 4502-3 Steering Wheel, Aluminum Wrap-your-own Flat 14" Banjo, Machine finish
- 4502-3-P Steering Wheel, Aluminum Wrap-your-own Flat 14" Banjo, Polished

9-HOLE

- 4501-9 Steering Wheel, Aluminum Wrap-your-own Flat 14" Classic, Machine finish
- 4501-9-P Steering Wheel, Aluminum Wrap-your-own Flat 14" Classic, Polished

STEERING WHEEL CENTER CAPS

These billet center caps are designed for All American Billet and Lecarra style steering wheels. Adapts to 3 on 1-3/4" Bolt Circle. They are made from 6061-T6 billet aluminum and are available in machine finish or polished.

- 4510 Center Caps for Lecarra Style Steering Wheels, Machined
- 4510-P Center Caps for Lecarra Style Steering Wheels, Polished



STEERING WHEEL COVERS

All American Billet Steering Wheel Covers are the finest, most luxurious steering wheel covers available anywhere. Handcrafted in California in solid black they are the perfect upgrade for our billet steering wheels.



GAUGE HOLDERS

Single Gauge Holder

These bullet style gauge holders are made from 6061-T6 billet aluminum and using our billet bracket mount to various sized columns. Available in machine finished, black anodized or polished.



4702-P
(Gauge Not Included)



47200-P



NOW IN BLACK ANODIZED

- | | |
|----------|--|
| 4701 | Gauge Holder, Single gauge, short, Machine finish |
| 4701-P | Gauge Holder, Single gauge, short, Polished |
| 4701-B | Gauge Holder, Single gauge, short, Black Anodized |
| 4702 | Gauge Holder, Single gauge, long, Machine finish |
| 4702-P | Gauge Holder, Single gauge, long, Polished |
| 4702-B | Gauge Holder, Single gauge, long, Black Anodized |
| 47150 | Gauge Holder Bracket for 1-1/2" column, Machine Finish |
| 47150 -P | Gauge Holder Bracket for 1-1/2" column, Polished |
| 47150 -B | Gauge Holder Bracket for 1-1/2" column, Black Anodized |
| 47175 | Gauge Holder Bracket for 1-3/4" column, Machine Finish |
| 47175-P | Gauge Holder Bracket for 1-3/4" column, Polished |
| 47175-B | Gauge Holder Bracket for 1-3/4" column, Black Anodized |
| 47200 | Gauge Holder Bracket for 2" column, Machine Finish |
| 47200-P | Gauge Holder Bracket for 2" column, Polished |
| 47200-B | Gauge Holder Bracket for 2" column, Black Anodized |
| 47225 | Gauge Holder Bracket for 2-1/4" column, Machine Finish |
| 47225-P | Gauge Holder Bracket for 2-1/4" column, Polished |
| 47225-B | Gauge Holder Bracket for 2-1/4" column, Black Anodized |

COLUMN DROPS

Column drops are made from 6060-T6 billet aluminum and are available in three styles: solid; open window; and closed window. They come in various column diameter and drop lengths to fit just about any application. The swivel easily adapts to different column and dash angles. Available in machine finish, polished and black.

SOLID + CLOSED WINDOW COLUMN DROPS

Feature a dual sided design on the same piece of billet. One side solid, the other close windowed.



SOLID COLUMN DROPS

- Column Drop 1-3/4" diameter x 2" drop
- Column Drop 1-3/4" diameter x 3" drop
- Column Drop 1-3/4" diameter x 4" drop
- Column Drop 1-3/4" diameter x 5" drop
- Column Drop 1-3/4" diameter x 6" drop
- Column Drop 1-3/4" diameter x 7" drop
- Column Drop 2" diameter x 2" drop
- Column Drop 2" diameter x 3" drop
- Column Drop 2" diameter x 4" drop
- Column Drop 2" diameter x 5" drop
- Column Drop 2" diameter x 6" drop
- Column Drop 2" diameter x 7" drop
- Column Drop 2-1/4" diameter x 2" drop
- Column Drop 2-1/4" diameter x 3" drop
- Column Drop 2-1/4" diameter x 4" drop
- Column Drop 2-1/4" diameter x 5" drop
- Column Drop 2-1/4" diameter x 6" drop
- Column Drop 2-1/4" diameter x 7" drop
- Column Drop 2-3/8" diameter x 3" drop
- Column Drop 2-3/8" diameter x 4" drop
- Column Drop 2-3/8" diameter x 5" drop

Machine Finish

Polished

Black

4317521	4317521-P	4317521-B
4317531	4317531-P	4317531-B
4317541	4317541-P	4317541-B
4317551	4317551-P	4317551-B
4317561	4317561-P	4317561-B
4317571	4317571-P	4317571-B
4320021	4320021-P	4320021-B
4320031	4320031-P	4320031-B
4320041	4320041-P	4320041-B
4320051	4320051-P	4320051-B
4320061	4320061-P	4320061-B
4320071	4320071-P	4320071-B
4322521	4322521-P	4322521-B
4322531	4322531-P	4322531-B
4322541	4322541-P	4322541-B
4322551	4322551-P	4322551-B
4322561	4322561-P	4322561-B
4322571	4322571-P	4322571-B
43237531	43237531-P	43237531-B
43237541	43237541-P	43237541-B
43237551	43237551-P	43237551-B

OPEN WINDOW COLUMN DROPS

Column Drop 1-3/4" diameter x 3" drop
Column Drop 1-3/4" diameter x 4" drop
Column Drop 1-3/4" diameter x 5" drop
Column Drop 1-3/4" diameter x 6" drop
Column Drop 1-3/4" diameter x 7" drop
Column Drop 2" diameter x 3" drop
Column Drop 2" diameter x 4" drop
Column Drop 2" diameter x 5" drop
Column Drop 2" diameter x 6" drop
Column Drop 2" diameter x 7" drop
Column Drop 2-1/4" diameter x 3" drop
Column Drop 2-1/4" diameter x 4" drop
Column Drop 2-1/4" diameter x 5" drop
Column Drop 2-1/4" diameter x 6" drop
Column Drop 2-1/4" diameter x 7" drop
Column Drop 2-3/8" diameter x 3" drop
Column Drop 2-3/8" diameter x 4" drop
Column Drop 2-3/8" diameter x 5" drop

Machine Finish

4317532
4317542
4317552
4317562
4317572
4320032
4320042
4320052
4320062
4320072
4322532
4322542
4322552
4322562
4322572
43237532
43237542
43237552

Polished

4317532-P
4317542-P
4317552-P
4317562-P
4317572-P
4320032-P
4320042-P
4320052-P
4320062-P
4320072-P
4322532-P
4322542-P
4322552-P
4322562-P
4322572-P
43237532-P
43237542-P
43237552-P

Black

4317532-B
4317542-B
4317552-B
4317562-B
4317572-B
4320032-B
4320042-B
4320052-B
4320062-B
4320072-B
4322532-B
4322542-B
4322552-B
4322562-B
4322572-B
43237532-B
43237542-B
43237552-B

CLOSED WINDOW COLUMN DROPS

Column Drop 1-3/4" diameter x 3" drop
Column Drop 1-3/4" diameter x 4" drop
Column Drop 1-3/4" diameter x 5" drop
Column Drop 1-3/4" diameter x 6" drop
Column Drop 1-3/4" diameter x 7" drop
Column Drop 2" diameter x 3" drop
Column Drop 2" diameter x 4" drop
Column Drop 2" diameter x 5" drop
Column Drop 2" diameter x 6" drop
Column Drop 2" diameter x 7" drop
Column Drop 2-1/4" diameter x 3" drop
Column Drop 2-1/4" diameter x 4" drop
Column Drop 2-1/4" diameter x 5" drop
Column Drop 2-1/4" diameter x 6" drop
Column Drop 2-1/4" diameter x 7" drop
Column Drop 2-3/8" diameter x 3" drop
Column Drop 2-3/8" diameter x 4" drop
Column Drop 2-3/8" diameter x 5" drop

Machine Finish

4317533
4317543
4317553
4317563
4317573
4320033
4320043
4320053
4320063
4320073
4322533
4322543
4322553
4322563
4322573
43237533
43237543
43237553

Polished

4317533-P
4317543-P
4317553-P
4317563-P
4317573-P
4320033-P
4320043-P
4320053-P
4320063-P
4320073-P
4322533-P
4322543-P
4322553-P
4322563-P
4322573-P
43237533-P
43237543-P
43237553-P

Black

4317533-B
4317543-B
4317553-B
4317563-B
4317573-B
4320033-B
4320043-B
4320053-B
4320063-B
4320073-B
4322533-B
4322543-B
4322553-B
4322563-B
4322573-B
43237533-B
43237543-B
43237553-B



FORD BRONCO PARTS & ACCESSORIES

NEW



1968-77 FORD BRONCO REAR INTERIOR DOOR PANELS

Our '68-'77 Bronco rear interior panels are a great way to clean up the rear of your Bronco. They are made from .063" 5052 Aluminum and are precisely cut for a perfect fit. Available in a machined finish or black anodized and our deluxe "Silverline Series". Sold in pairs.

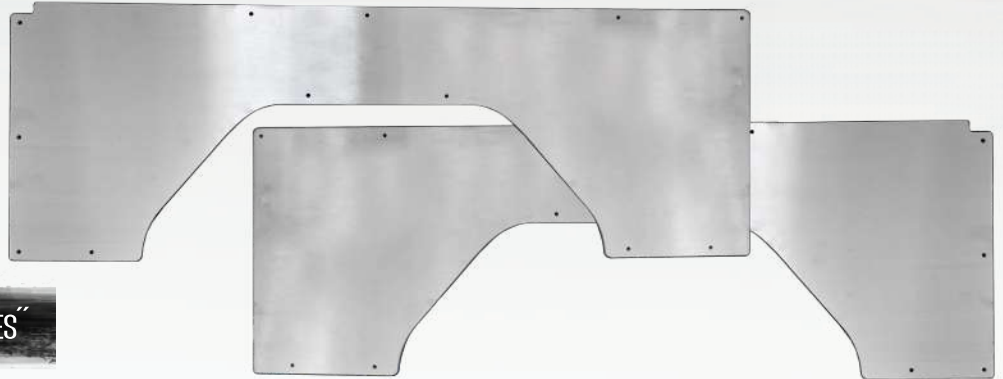

ALSO AVAILABLE IN "SILVERLINE SERIES"

IP-6877FB
IP-6877FB-B
IP-6877FB-SL

Bronco Interior Panel - Machined
Bronco Interior Panel - Black Anodized
Bronco Interior Panel - "Silverline Series"

1968-77 FORD BRONCO DOOR PANELS



Our '68-'77 Bronco door panels are made from .063" 5052 Aluminum and are precisely cut for a perfect fit. Available in a machined finish or black anodized. Sold in pairs

56

DP-6877FB
DP-6877FB-B

Bronco Door Panel - Machined
Bronco Door Panel - Black Anodized

"SILVERLINE SERIES" 1968-77 FORD BRONCO DOOR PANELS

These are the "Deluxe" version of our Bronco door panels. After being cut from .125 5051 Aluminum they are anodized then we "Silverline" them by CNC cutting in an accent line. Sold in pairs.

DP-6877FB-SL

Bronco Door Panel - "Silverline Series"



FORD BRONCO/UNIVERSAL BILLET GRAB HANDLE

These Billet Grab Handles are universal and can be mounted on any flat surface. Made from 6061-T6 aluminum. Overall dimensions are 7-3/4" X 1-1/8" and mounting holes are 6-1/4" center-to-center. Mounts with 1/4"-20 bolts (not included). - SOLD INDIVIDUALLY



- GH Billet Grab Handle - Machined (EACH)
- GH-P Billet Grab Handle - Polished (EACH)
- GH-B Billet Grab Handle - Black Anodized (EACH)

'66-'77 BRONCO BILLET STEERING COLUMN BEZEL

Replace your plastic steering column dash plate with this stylish billet plate. They are machined from 6061-T6 aluminum and come in Machined finish or Polished. They fit 2.25" steering columns. Made in the U.S.A.



- SCB-FB6677 Bronco Steering Column Bezel - Machined
- SCB-FB6677-P Bronco Steering Column Bezel - Polished
- SCB-FB6677-SL Bronco Steering Column Bezel - "Silverline Series"

DOOR HANDLE - 66-77 BRONCO / 64-66 & 69-70 MUSTANG

Add some added class to your ride. These billet door handles have a 1/2" lower profile than stock and are a direct replacement for the stock handles. CNC Machined from 6061-T6 aluminum and come in 3 finishes: machined, polished and the original Silverline Series (powder coated with machined highlights). Mounting hardware is included. They also fit 64-66 and 69-70 Mustang. Sold in pairs.



- DH-6677FB Bronco Door Handle - Machined
- DH-6677FB-P Bronco Door Handle - Polished
- DH-6677FB-SL Bronco Door Handle - "Silverline Series"

'68-'77 BRONCO BILLET INTERIOR DOOR CUPS

Direct fit replacement for your stock 1968 - 1977 Ford Bronco plastic door cups. They are machined from 6061-T6 billet aluminum and come in Machined finish or Polished. Made in the U.S.A. and sold in pairs

- DHC-FB6877 Bronco Door Cup - Machined
- DHC-FB6877-P Bronco Door Cup - Polished
- DHC-FB6877-SL Bronco Door Cup - "Silverline Series"



66-'77 BRONCO TAILGATE LATCH

These latches will fit 66-77 Bronco's as well as '64-'72 Style fleetside and F100 & F250 trucks. The billet tailgate mounting plate and handles are a direct replacement for the stock units and are CNC machined from 6061-T6 aluminum. Available in 3 finishes: Machined, polished and the original Silverline Series (powder coated with machined areas). Sold as a set and includes stainless steel mounting hardware and billet washers for a nice clean look. Uses your existing lever hardware.



- TGL-6677FB Bronco Tailgate Latch - Machined
- TGL-6677FB-P Bronco Tailgate Latch - Polished
- TGL-6677FB-SL Bronco Tailgate Latch - "Silverline Series"

CHEVY TRUCK SIDE MARKER LIGHT BEZELS

Add style to your truck with these All American Billet side marker light bezels. Our bezels are machined from 6061-T6 Aluminum, are made to last and look great and available in polished and black anodized finishes. Available for '68 - '72 Chevy trucks. Sold in pairs. (*Lens is **NOT** included.*)

- BSML-P Bezel, Side Marker Light, Polished, Pair
- BSML-B Bezel, Side Marker Light, Black Anodized, Pair
- BSML-DW-P Bezel, Dual Window Side Marker Light, Polished, Pair
- BSML-DW-B Bezel, Dual Side Marker Light, Black Anodized, Pair



CHEVY TRUCK TAIL LIGHT BEZELS

67-'72 Chevy Trucks

Add style to your truck with All American Billet taillight bezels. Machined from 6061-T6 aluminum and available in Machined Finish, Polished or Black anodized. Made in the U.S.A. to last and look great! *Sold in pairs.*

BEZELS DO NOT COVER STOCK TRIM HOLES

- BTL-6772-C10 Tailgate Bezel, Machined
- BTL-6772-C10-P Tailgate Bezel, Polished
- BTL-6772-C10-B Tailgate Bezel, Black Anodized



CHEVY TRUCK DOOR JAMB VENTS

Dress up the door pillar of your truck with these All American Billet door jamb vents. Machined from 6061-T6 aluminum these vents are made to last and look great. Available for '58-'66 GM Fleetside trucks, '71 - '72 Chevy trucks, Chevelle & 70-92 Camaro, available in polished and our exclusive "Silverline Series" Sold individually.

- DJV-P Door Jamb Vent, Polished, ea.
- DJV-BG Door Jamb Vent, "**Silverline Series**", ea.



PRECISION PARTS

'58-'66 GM FLEETSIDE TRUCKS BILLET TAILGATE LATCH KIT



1958-66 GM Fleetside Trucks - Get rid of those ugly chains that ruin your paint! The All American Billet Tailgate Latch assembly includes everything needed to convert your truck to a more modern latch assembly. Kit is manufactured with 6061 aluminum cup and handle and stainless steel brackets. Includes hardware and assembly instructions.



INSIDE VIEW OF LATCH MECHANISM

- TGL Tailgate Latch assembly for original tailgates - Machined
- TGLA Tailgate Latch assembly for aftermarket tailgates - Machined
- TGL-P Tailgate Latch assembly for original tailgates - Polished
- TGLA-P Tailgate Latch assembly for aftermarket tailgates - Polished

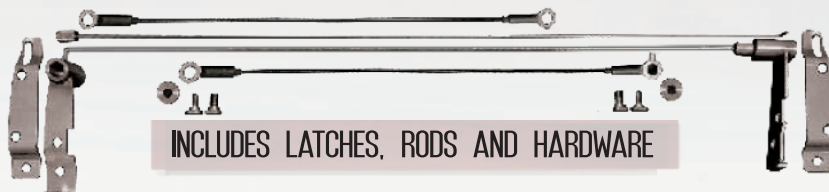

INCLUDES LATCHES, RODS AND HARDWARE

WINDSHIELD WIPER POST COVERS

High quality, American Made and machined from 6061-T6 Aluminum, these covers dress up the post when you do not want to run wipers. Easy installation and removal for show or driving. Each pair includes two set screw sizes to fit most size post.



- WWPCS Wiper Post Cover, Machine Finish, (pr)
- WWPCS-P Wiper Post Cover, Polished, (pr)
- WWPCB Wiper Post Cover, Bullet, Machine Finish, (pr)
- WWPCB-P Wiper Post Cover, Bullet, Polished, (pr)
- WWPCB-BG Wiper Post Cover, Bullet, "Silverline Series" (pr)

LARGE POST COVERS INSIDE DIAMETER APPROX. 11/16" AND APPROX 3/4" DEEP.

SMALL POST COVERS INSIDE DIAMETER IS APPROX. 9/16" AND APPROX. 5/8" DEEP.



- WWPC1 Wiper Post Cover, Machine Finish, small, (pr)
- WWPC1-P Wiper Post Cover, Polished, small, (pr)
- WWPCB1 Wiper Post Cover, Bullet, Machine Finish, small, (pr)
- WWPCB1-P Wiper Post Cover, Bullet, Polished, small (pr)

BILLET GAS DOORS

These gas doors are made from 6061-T6 aluminum and are available in a variety of finishes to add class to any vehicle. Comes with stainless steel mounting hardware.



- DGS Billet Gas Door, Machined
- DGS-P Billet Gas Door, Polished
- DGS-BG Billet Gas Door, "Silverline Series"

All American Billet Door props are machined from 6061-T6 aluminum. These door props are made to allow spectators to "look but not touch" your interior. They will hold your door open approx. 12" and are easy to install and remove. They are made to work with most post and bear claw latch assemblies.

DOOR PROPS

- DP Door Prop - Machined
- DP-P Door Prop - Polished
- DP-B Door Prop - Black Anodized

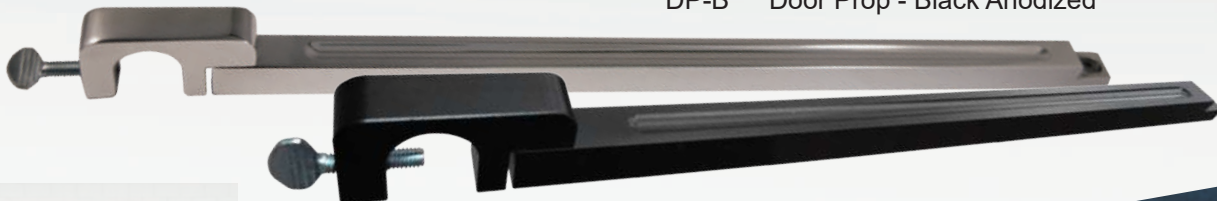

NEW

CUSTOM BILLET PARTS

CALL FOR PRICING 1(844) BILLET1 (245-5381)



NEW

BILLET EMBLEM SETS

Tired of cheap plastic emblems that crack and fade? All American Billet Emblems are fashioned from aircraft quality billet aluminum and are designed to last. These engine emblems are clean cut, durable and stylish. Available in Machined or Polished finishes. (sold in pairs)



BILLET EMBLEM SET - "8 LS1"

ES-8LS1 Machined (Pair)
ES-8LS1-P Polished (Pair)



BILLET EMBLEM SET - "8 LS2"

ES-8LS2 Machined (Pair)
ES-8LS2-P Polished (Pair)



BILLET EMBLEM SET - "8 LS3"

ES-8LS3 Machined (Pair)
ES-8LS3-P Polished (Pair)



BILLET EMBLEM SET - "8 LSX"

ES-8LSX Machined (Pair)
ES-8LSX-P Polished (Pair)



BILLET EMBLEM SET - "8 468"

ES-8468 Machined (Pair)
ES-8468-P Polished (Pair)



BILLET EMBLEM SET - "LSA"

ES-LSA Machined (Pair)
ES-LSA-P Polished (Pair)



BILLET EMBLEM SET - "SUPERCHARGED"

ES-8LS3 Machined (Pair)
ES-8LS3-P Polished (Pair)

BILLET FENDER WASHERS

All American Billet fender washers are machined from 6061-T6 billet aluminum. These washers are used to add class and to protect your finish. Sold with or without stainless steel hardware & sold individually to meet your needs.



POLISHED OR **SILVERLINE SERIES WASHERS**
ADD ONE DOLLAR PER WASHER

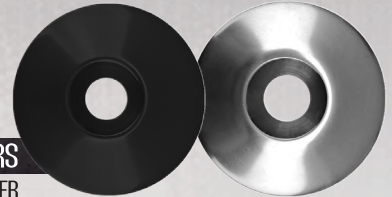

WF101



WF102



WF103



WF104



WF105

WF101
Washer, Fender
1" O.D.
WF101-1
w/ 10-24 x 1" SS Bolt

WF102
Washer, Fender
1" O.D.
WF102-1
w/ 5/16-18 x 1" SS Bolt

WF103
Washer, Fender
7/8" O.D.
WF103-1
w/ 3/8-16 x 1" SS Bolt

WF104
Washer, Fender
3/4" O.D.
WF104-1
w/ 5/16-18 x 1" SS-Bolt

WF105
Washer, Fender
11/16" O.D.
WF105-1
w/ 1/4-20 x 1" SS-Bolt



WF106



WF107

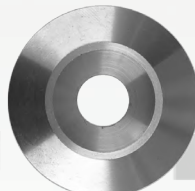

WF108



WF109



WF110

WF106 Washer, Fender
9/16" O.D.
WF106-1
w/ 10-24 x 1" SS Bolt

WF107 Washer Fender
2-1/4" O.D.
*Fits 7/16-14 x 1-3/4" L SS Bolt
(NOT INCLUDED)*

WF108 Washer Fender
1-1/2" O.D.
WF108-1
w/ 3/8-16 x 1-1/2" L SS

WF109 Washer,
Fender 2" O.D.
*Fits 7/16-14 x 1-3/4" L SS Bolt
(NOT INCLUDED)*

WF110 Washer, Fender
1" O.D.
WF110-1
w/ 1/4-20 x 1" SS Bolt

FENDER WASHER KITS

Convenient kits with washers and bolts neatly organized so they are available when needed. Easy to re-order to keep the kit fully stocked.

-Machined from 6061-T6 billet aluminum
-Stainless steel hardware included
-Neatly organized in divided PVC storage case



AVAILABLE IN SILVERLINE SERIES 120 PC SET! INCLUDES

- (10) WF101 Washer, Fender 1" O.D.
- (10) 10-24 x 1" SS Bolt
- (10) WF102 Washer, Fender 1" O.D.
- (10) 5/16-18 x 1" SS Bolt
- (10) WF103 Washer, Fender 7/8" O.D.
- (10) 3/8-16 x 1" SS Bolt
- (10) WF104 Washer, Fender 3/4" O.D.
- (10) 5/16-18 x 1" SS Bolt
- (10) WF105 Washer, Fender 11/16" O.D.
- (10) 1/4-20 x 1" SS Bolt
- (10) WF106 Washer, Fender 9/16" O.D.
- (10) 10-24 x 1" SS Bolt

WF-KIT1-SL "Silverline Washers"
WF-KIT1 Machined Washers

'63-72' CHEVY C-10 FRONT SUSPENSION

Available in Coilover and Air Bag versions, Both versions are available with either billet aluminum or fabricate control arms and include: crossmember, control arms, upper control arm mounts, motor mounts, inner frame support, rack and pinion adapter, all hardware needed to install.

FITMENT NOTES:

Wheels = 19"+ or spacers may be needed to clear tie rod ends
Ride height (between bottom of frame and ground): 6" with a 30" tall tire and 2.5" drop spindles. Ride height can be adjusted by swapping spindles or changing tire and wheel size

Easy camber and caster adjustment

Narrows track width a total of 3"

Moves wheels forward for a more centered location with the wheel opening in the front fenders

Customers can later change to an airbag set up by simple changing or modifying the upper control arms mounts. Billet arms will require a bag plate

Crossmember will accept either manual or power rack and pinion (Mustang II style)

Completely bolt-on and does not require welding or frame notching for rack and pinion

Does not require modification of spindle for steering

Lower cross member ties into the upper control arm brackets, inner frame block and the motor mounts, creating a stronger assembly

Low profile design keeps the lowest part of the cross member above the lowest part of the frame rail

Air Bag version is designed for Slam Specialties RE-8 bags (not included)



FABRICATED ARMS WITH AIRBAGS

BILLET ARMS WITH COILOVERS

6372GMFS-BACO
Front suspension w/billet arms & coilover brackets

6372GMFS-BAAB
Front suspension w/billet arms & air bag brackets

6372GMFS-FACO
Front suspension w/fabricated arms & coilover brackets

6372GMFS-FAAB
Front suspension w/fabricated arms & air bag brackets

BILLET TRAILING ARMS

Get rid of those rusty and weak stock trailing arms and add style to your truck with these billet trailing arms. Arms are made from 6061-T6 billet aluminum and weigh approx. 20 lbs less than stock (per set). Includes 2 trailing arms, steel brackets, grade 8 hardware, spacers, new polyurethane bushings and instructions. Coilovers sold separately. Using 14" coilovers, drops the rear end approx. 4".

1960-62

TACT6062 BILLET TRAILING ARM KIT

1963-72

TACT6372 BILLET TRAILING ARM KIT

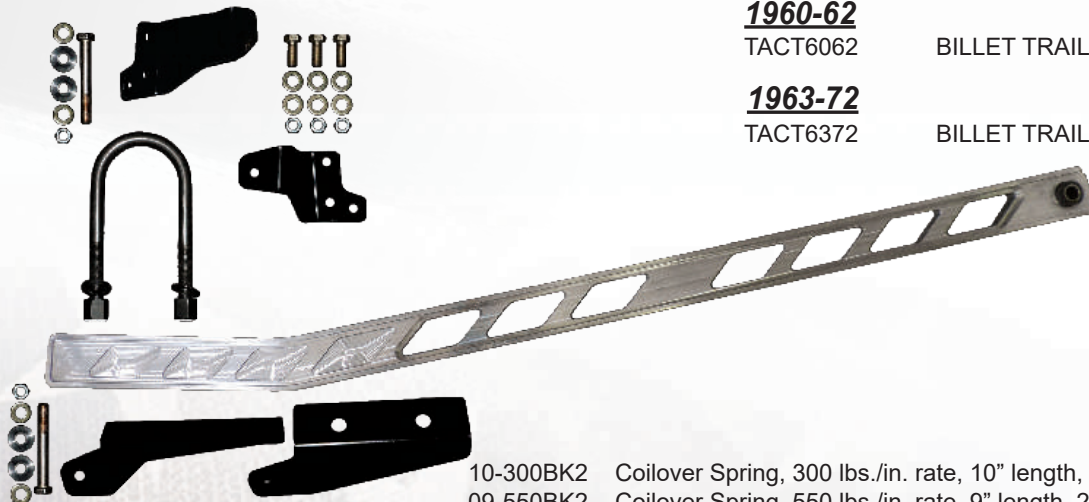

10-300BK2 Coilover Spring, 300 lbs./in. rate, 10" length, 2.5" I.D, Black, (pr)
09-550BK2 Coilover Spring, 550 lbs./in. rate, 9" length, 2.5" I.D, Black, Pair
AS-656 13" Coilover Shock w/ hardware, bushings & sleeves (5/8")
AS-651 Coilover Shock w/ hardware, bushings & sleeves (5/8")
AS-655 Coilover Shock w/ hardware, bushings & sleeves (5/8")

'63-72' ADJUSTABLE TRAILING ARM/CARRIER BEARING

Adjustable Trailing Arm/Carrier Bearing for C10's. Bolts in at top and side of frame, rather than using bolts at bottom of frame. Exhaust ports will accept up to 3" diameter pipe. Raised center section to accommodate raised drive line.

Carrier bearing mounts will need to be used from stock crossmember. Multiple mounting locations for trailing arms.

6387GMATAACBC

GM Adjustable Trailing Arm/Carrier Bearing Crossmember

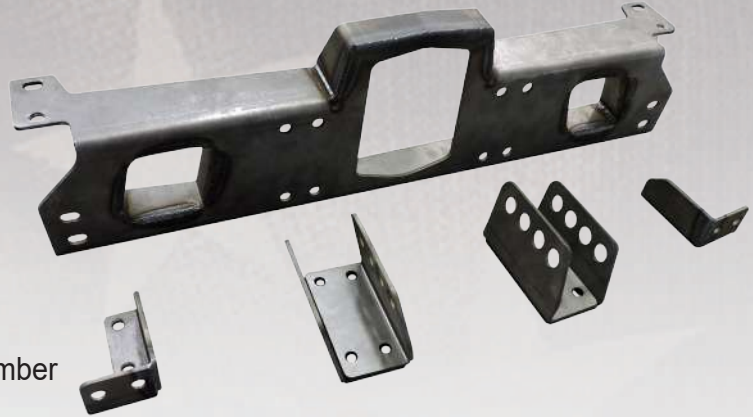

'63-72' CHEVY/GMC TRUCK BOLT-IN WATTS LINK KIT

Completely bolt-in watts link system for 1963 - 1972 C-10 trucks that will work with factory trailing arms and springs, or with our billet trailing arms and coilovers. This kit will keep the factory rear end centered throughout its travel while, providing a truss-like structure for the axle tubes. Our watts link kit will also allow for slight pinion adjustment and includes extra mounting holes at the frame brackets to maintain correct watts link geometry when going with a lower stance. Comes complete with Grade 8 hardware.

'63-'72 Chevy/GMC Truck Bolt-In
Watts Link with Fabricated Center Crank

6272GMWL



'60-62' GM BOLT-ON AIR BAG REAR SUSPENSION KIT

The only 100% bolt-on rear bag kit available for the 1960 - 1962 C-10 that will lay frame on the ground and retain a 6" ride height with air springs on a 30" tall tire. The kit comes standard with parallel four-link and a watts-link system to keep the axle centered throughout its travel. This kit also utilizes our 2-piece notch design, which creates a much stronger part by eliminating excessive welding. All parts are manufactured and engineered using precision equipment and CAD software. Comes complete with everything pictured, plus Grade 8 hardware.

6062GMRBK



'63-87' C10 TRANSMISSION CROSSMEMBER

Comes with everything needed to install, bolts in at the side of the frame rail. Multiple transmission mounting holes. Uses a 3/16" thick shim at both ends of the crossmember, making installation easier.



GM Transmission Crossmember
6387TC

'67-72' FORD F100 FRONT SUSPENSION

The 1967 - 1972 F-100 IFS kit is completely bolt-on, and eliminates the front I-beam suspension found on these trucks. This kit utilizes 2003+ Ford Crown Victoria ball joints, steering knuckles, hubs and brakes. Hub to hub width is about 62.5 inches, which is roughly 5 inches narrower than a stock Crown Victoria crossmember. A Mustang II style rack and pinion will replace the factory F-100 steering components and will allow the option to run either a manual or power rack. Both coilover and air bagged versions will yield a 6" ride height from the lowest part of the frame to the ground. The air bagged version will lay the lowest part of the F-100 frame on the ground, using a 29" tall tire.



COILOVER BRACKETS

6772F100FS-FACO
6772F100FS-FAAB



AIRBAG BRACKETS

Front suspension w/fabricated arms & coilover brackets
Front suspension w/fabricated arms & airbag brackets



BILLET HOOD HINGES

'73-80' CHEVY TRUCKS

These billet Hood Hinges for 1973 - 1980 Chevy trucks are a great way to make your engine compartment pop! They are machined from 6061-T6 aluminum and engineered to operate smoothly. Our hinges are manufactured to last and come with larger bearings, stainless steel gas struts and stainless steel hardware. We offer 2 styles (Plain or Cutout) in 3 finishes (Machined, Polished and "Silverline Series"). Sold in pairs.



PLAIN

- HH-7380CT Machine
- HH-7380CT-P Polished
- HH-7380CT-B Black Anodized

CUTOUTS

- HH-7380CT-C Machine
- HH-7380CT-C-P Polished
- HH-7380CT-C-SL "Silverline"

All American Billet hood hinges for '67-72 Chevy Trucks are a great way to make your engine compartment pop. They are machined from 6061-T6 aluminum and engineered to operate smoothly. Our hinges are manufactured to last and come with larger bearings, stainless steel gas springs and stainless steel hardware.

We offer 2 styles (Plain or Cutout) in 3 finishes (machined, polished and our exclusive Silverline Series). Sold in pairs.

'67-72' CHEVY TRUCKS



PLAIN

- HH-6772CT Machine
- HH-6772CT-P Polished
- HH-6772CT-B "Black Anodized"

CUTOUTS

- HH-6772CT-C Machined
- HH-6772CT-C-P Polished
- HH-6772CT-C-S "Silverline"

'67-'72' C-10 HOOD HINGES FOR LOWERED TRUCKS

HOOD HINGES THAT MOUNT TO THE FIREWALL FOR LOWERED TRUCKS

These billet hood hinges fit 1967 - 1972 GM Trucks and mount on the fenders (using an existing hole on fender for easy installation and stock hood mount locations). They are designed to work with wheel tubs such as SloshTubz. They will clear a 29" tall tire and allow the hood to open to approximately 27". Available in Machined finish or Polished. Made in the U.S.A. (sold in pairs)



PLAIN

HH-L-6772CT
 HH-L-6772CT-P
 HH-L-6772CT-SL



Lowered Hood Hinges - Machine
 Lowered Hood Hinges - Polished
 Lowered Hood Hinges - "Silverline"

These billet Hood Hinges for 1960 - 1966 Chevy trucks are a great way to make your engine compartment pop! They are machined from 6061-T6 aluminum and engineered to operate smoothly. Our hinges are manufactured to last and come with larger bearings, stainless steel gas struts and stainless steel hardware. We offer 2 styles (Plain or Cutout) in 3 finishes (Machined, Polished and our exclusive "Silverline Series"). Sold in pairs.

'60-'66' CHEVY TRUCKS



PLAIN

HH-6066CT Machine
 HH-6066CT-P Polished
 HH-6066CT-SL "Silverline"



CUTOUTS

HH-6066CT-C Machine
 HH-6066CT-C-P Polished
 HH-6066CT-C-SL "Silverline"

'58-59' CHEVY TRUCKS

These billet Hood Hinges for 1958 - 1959 Chevy trucks are a great way to make your engine compartment pop! They are machined from 6061-T6 aluminum and engineered to operate smoothly. Our hinges are manufactured to last and come with larger bearings, stainless steel gas struts and stainless steel hardware. We offer 2 styles (Plain or Cutout) in 3 finishes (Machined, Polished and our exclusive "Silverline Series"). Sold in pairs

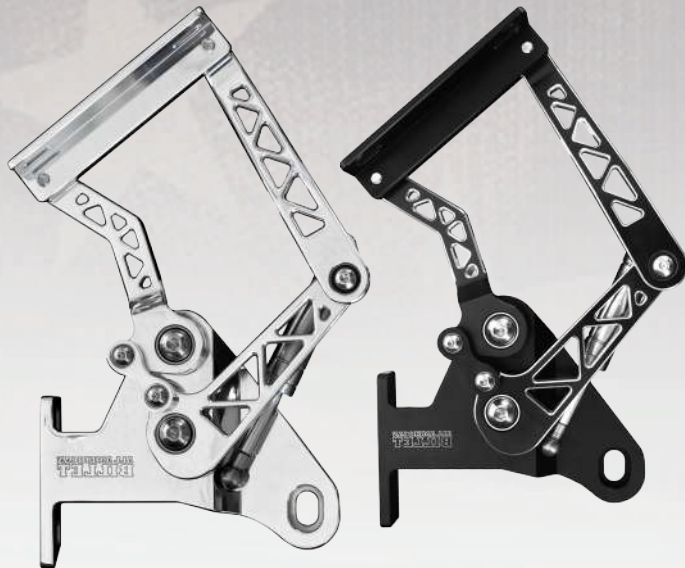

PLAIN

HH-5859CT	Machine
HH-5859CT-P	Polished
HH-5859CT-B	Black Anodized

CUTOUTS

HH-5859CT-C	Machine
HH-5859CT-C-P	Polished
HH-5859CT-C-SL	"Silverline"

'55-57' CHEVY TRUCKS

All American Billet hood hinges for 1955-57 GM Trucks are a great way to make your engine compartment pop. Machined from 6061-T6 aluminum and engineered to operate smoothly. Our hinges are manufactured to last and come with larger bearings, stainless steel gas springs and stainless steel hardware. We offer 2 styles (Plain or with Cutouts) in 3 finishes (machined, polished and our exclusive Silverline Series). Sold in pairs.



PLAIN

HH-5557CT	Machine
HH-5557CT-P	Polished
HH-5557CT-SL	"Silverline"

CUTOUTS

HH-5557CT-C	Machine
HH-5557CT-C-P	Polished
HH-5557CT-C-SL	"Silverline"