



## Installation instructions

Akrapovič Exhaust Systems:

**Tail Pipe, Slip-On, Sports Cup,  
Evolution, Evolution-Race and SlipOn-Race**  
for the

**Porsche 911 3.6L (type 997) GT3/GT3 RS**

**Porsche 911 3.8L (type 997) GT3/GT3 RS**

Congratulations on purchasing an Akrapovič exhaust system. Please read the entire installation manual prior to undertaking any activities related to installation of your new Akrapovič exhaust system. In case you do not fully understand the manual or any of its parts, please contact your authorized dealer!

This product should be installed by someone with sufficient knowledge of exhaust systems and their installation, and appropriate hand or power tools. If you are not qualified for this work, please utilize a certified mechanic for installation. By installing Your Akrapovič exhaust system, you indicate that you have read the installation manual in its entirety and you agree with the terms stated herein.

It is your responsibility to follow all installation instruction guidelines supplied with the Akrapovič exhaust system and undertake all necessary safety precautions. Akrapovič d.d. assumes no responsibility for damages occurring from misuse, abuse, improper installation, improper operation, lack of responsible care, or all previously stated reasons resulting from incompatibility with other manufacturer's products and/or systems.

## **IMPORTANT INFORMATION**

### **Exclusion of Certain Liability**

1. The manufacturer, importer or dealer shall not be liable for any incidental damage including personal injury or any other damages caused by improper installation or operation of the Akrapovič exhaust system. When installing the Akrapovič exhaust system be careful that the exhaust system does not touch other parts sensitive to high temperature.
2. Akrapovič makes no representation or warranties with regard to damage caused by the improper installation, use and maintenance of the Akrapovič exhaust system. The warranty is limited to defects recognized by our technical department and due to normal use, and excludes items subject to normal wear (gaskets and damping wool). The guarantee is void in case of accident, modification, improper or competition use.
3. Do not attempt to install the Akrapovič exhaust system on a vehicle model for which it was not made or tested by Akrapovič.
4. When the exhaust system gets very hot during operation, be careful not to burn yourself on the exhaust system or parts which are in direct contact with it, even when the engine is not running. Also protect other people, especially children, from the injuries mentioned above.

1. In some cases Akrapovič exhaust system kits contain chemical products (ceramic anti-seizing grease; bolt sealant). Handle with care, do not inhale or swallow. Avoid excessive contact with skin, eyes or mucous membranes. Keep out of reach of children.
2. Technical specifications of Akrapovič exhaust systems and related products are subject to change without notice.
3. Before removing the original exhaust system from your vehicle, please compare the parts you received with the list of materials provided in the installation manual in order to assure that you have all the parts necessary for the installation of your new Akrapovič exhaust system.
4. Although this manual consists of instructions for installation in written form, as well as photographs and pictures representing individual steps of the installation, please note that the photographs and pictures are symbolic and are intended for representation of general overview only. The photographs and pictures contained herein should serve as a guideline only and actual installation of the exhaust system may not correspond with the photographs and pictures entirely.
5. The process of uninstalling the original exhaust system may vary depending on the existing exhaust system. Please follow the original exhaust system manufacturer's instructions for uninstalling the original exhaust system.

## Symbols

The following symbols are used throughout these installation instructions:



TOOLS REQUIRED



TIGHTENING TORQUE



INSTALLATION TIP



CAUTION OR WARNING



**USE BOLT SEALANT;** Apply 3 to 4 small drops of bolt sealant onto the cleaned and degreased threads before tightening the bolts. **WARNING! Avoid contact with skin, eyes and mucous membranes. Do not inhale fumes. Keep out of the reach of children.**



**USE ANTI-SEIZE LEAD-FREE COPPER PASTE** (black tube); Provides trouble-free and long-lasting protection against seizing, corrosion and rusting of bolts, threaded ends, nuts, joints, etc. Also protects against vibration, wear and impact. **WARNING! Avoid eye contact. Avoid excessive skin contact. Keep out of reach of children.**





**USE ANTI-SEIZING GREASE** (white tube); Prevents seizing, corrosion and excessive wear between the titanium components of your exhaust system. **WARNING! Avoid eye contact. Avoid excessive skin contact. Keep out of reach of children.**



T-handle 7mm wrench  
T-handle 10 mm wrench  
T-handle 13 mm wrench  
T-handle swiveling 8 mm wrench  
T-handle swiveling 13 mm wrench  
T-handle 6 mm three hexagon key wrench  
Combination 13 mm wrench  
Combination 16 mm wrench  
Combination 22 mm wrench  
Small cross head screwdriver  
Torx 25  
Torx 30  
Cutting nippers

 **BEFORE INSTALLING, CHECK THE SCHEMATIC OF THE EXHAUST SYSTEM!**

 **IF ANY ITEMS IN THE AKRAPOVIČ EXHAUST SYSTEM PACKAGE ARE MISSING, PLEASE CONTACT YOUR AUTHORIZED DEALER. KEEP THE SCHEMATIC FOR FUTURE REFERENCE.**

 **THESE INSTALLATION INSTRUCTIONS MUST BE READ CAREFULLY IN ORDER TO ENSURE PROPER INSTALLATION AND OPERATION OF THE AKRAPOVIČ EXHAUST SYSTEM.**

 **THE EXHAUST SYSTEM CAN BE EXTREMELY HOT. ALLOW THE EXHAUST AND ENGINE TO COOL DOWN BEFORE BEGINNING INSTALLATION.**

 **WE ADVISE YOU TO LEAVE INSTALLATION TO A QUALIFIED SERVICEMAN. IMPROPER INSTALLATION MAY RESULT IN A SHORTER LIFETIME OF THE EXHAUST SYSTEM AND/OR DAMAGE TO THE VEHICLE.**

 **WHEN INSTALLING AN AFTERMARKET AKRAPOVIČ EVOLUTION EXHAUST SYSTEM, WHICH IS DEVELOPED FOR USE ON CLOSED TRACK, WE RECOMMEND REMAPPING OF THE ECU TO PREVENT POSSIBLE “ENGINE CHECK LIGHT” WARNING SIGNAL.**

## REMOVAL OF STOCK EXHAUST SYSTEM:

Put the vehicle onto a car lift.

- ! **WARNING:** make sure, that car lifting is safely and correctly done or you risk vehicle damage, injury or even death!
1. For Tail Pipe, Slip-On, Sports Cup, Evolution, Evolution-Race and SlipOn-Race: unscrew three M8 nuts from stock tail pipe piece and remove the tail pipe (**Figure 1**).



Figure 1

2. For Slip-On, Sports Cup, Evolution, Evolution-Race and SlipOn-Race: unscrew both tail lights (Figure 2).



Figure 2

3. For Slip-On, Sports Cup, Evolution, Evolution-Race and SlipOn-Race: undo the lights connectors and remove the tail lights (Figure 3).



Figure 3



4. For Slip-On, Sports Cup, Evolution, Evolution-Race and SlipOn-Race: unscrew the marked bolts on both sides of the vehicle (Figure 4, 5, 6, 7).



Figure 4



Figure 5



Figure 6



Figure 7

5. For Slip-On, Sports Cup, Evolution, Evolution-Race and SlipOn-Race: undo the number plate light connector and remove the rear bumper (Figure 8).

! **WARNING:** be careful not to damage the electrical lead, bumper or any other part of the car during removal!



Figure 8

6. For Slip-On, Sports Cup, Evolution, Evolution-Race and SlipOn-Race: unscrew the marked bolts on both sides of the vehicle and remove exhaust heat shields (Figure 9, 10, 11, 12).



Figure 9





Figure 10



Figure 11





Figure 12

7. For Slip-On, Sports Cup, Evolution, Evolution-Race and SlipOn-Race: unscrew the marked nuts of the flanges, undo the vacuum tubes of the exhaust valves on both sides of the vehicle and remove the side mufflers (Figure 13, 14, 15).



Figure 13



Figure 14

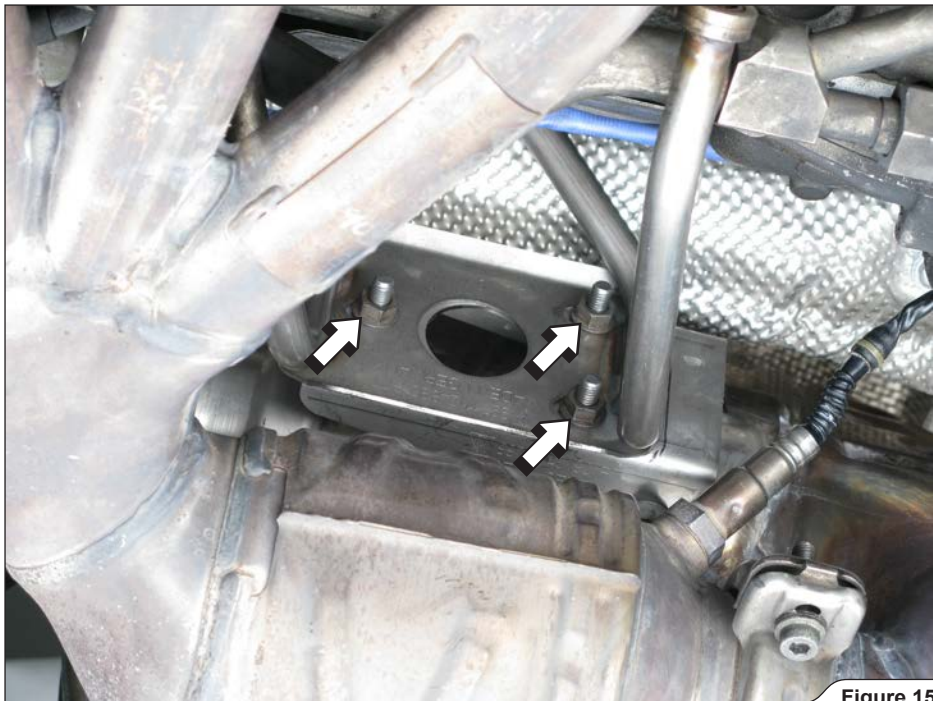

Figure 15

8. For Slip-on, Sports cup, Evolution, Evolution-Race and SlipOn-Race: unscrew the marked bolts of the central muffler clamps and remove the muffler off the vehicle (Figure 16).



Figure 16



9. **For Evolution and Evolution-Race:** unscrew the lambda sensors (**Figure 17**) and marked bolts of the headers on both sides of the vehicle (**Figure 18**). Remove the headers off the vehicle.
- ! **CAUTION:** make sure not to damage the sensors' electrical leads during this process!

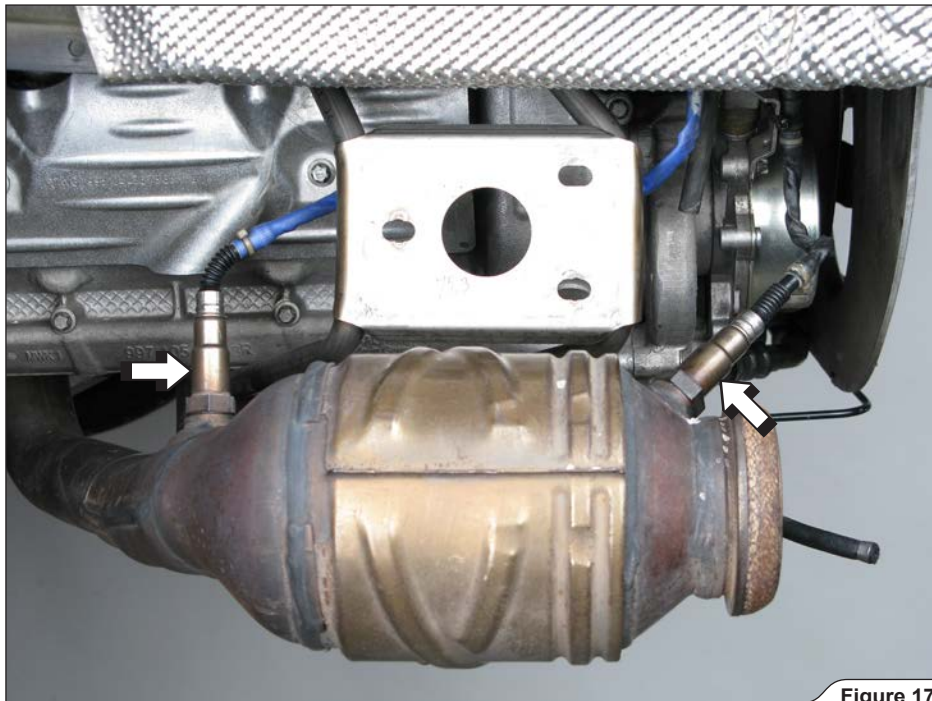

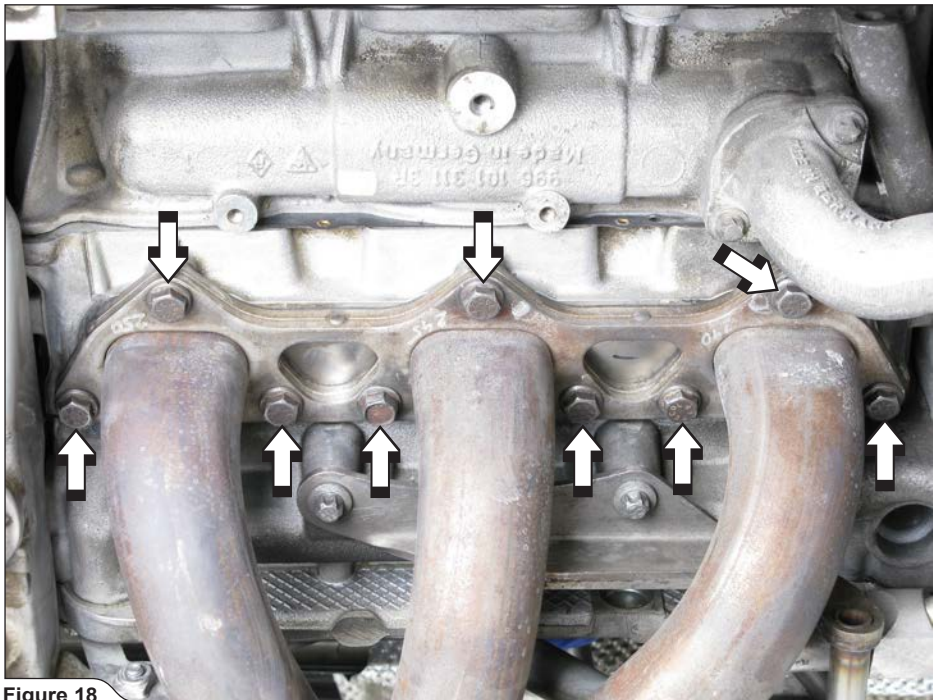

Figure 18

## **INSTALLATION OF THE AKRAPOVIČ EXHAUST SYSTEMS:**

1. **For Evolution and Evolution-Race:** set the Akrapovič headers with stock gaskets and tighten the stock bolts to a specified torque using criss-cross pattern in three steps (**Figure 19**).

! **CAUTION:** use new exhaust port gaskets!

! **WARNING:** use anti-seize copper paste on all bolt threads!

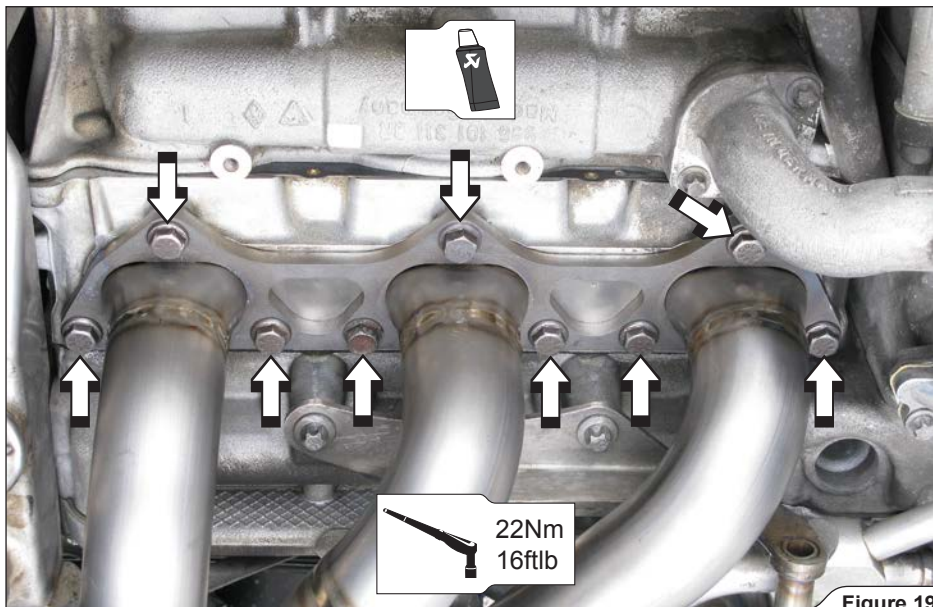

Figure 19



2. **For Evolution and Evolution-Race (left side of the vehicle):** attach the lambda sensor's black electrical lead with a plastic tie and displace the blue electrical lead's bracket as shown (Figure 20). Cut away excess of the tie.

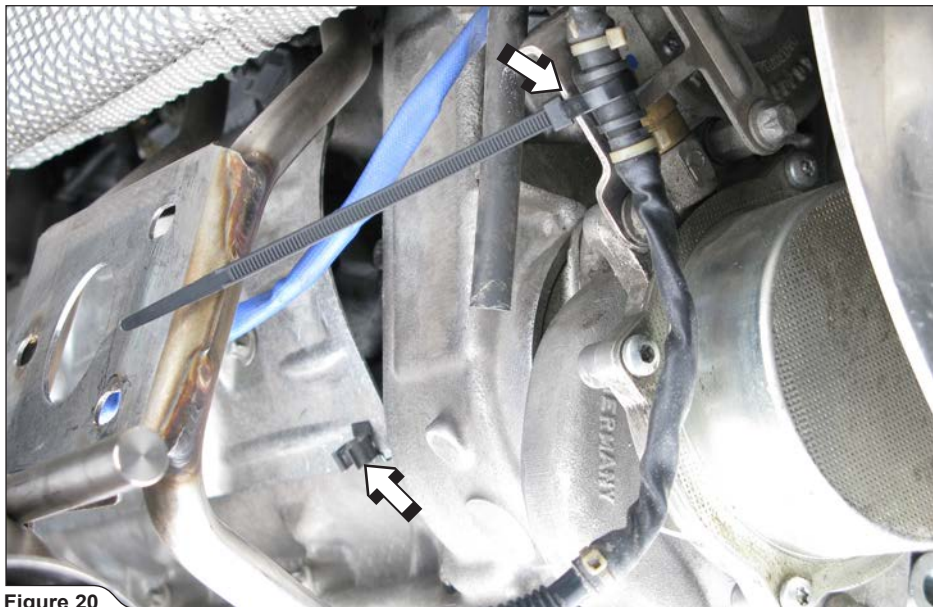

Figure 20

3. **For Evolution and Evolution-Race (right side of the vehicle):** attach the lambda sensor's black electrical lead with a plastic tie and turn upside down the blue electrical lead's bracket as shown (**Figure 21**). Cut away excess of the tie.



**Figure 21**

4. For Evolution and Evolution-Race: install all four lambda sensors on both sides of the vehicle (Figure 22).

! **WARNING:** use anti-seize copper paste only on sensors' threads!

! **CAUTION:** make sure not to damage the sensors' electrical leads during this process!

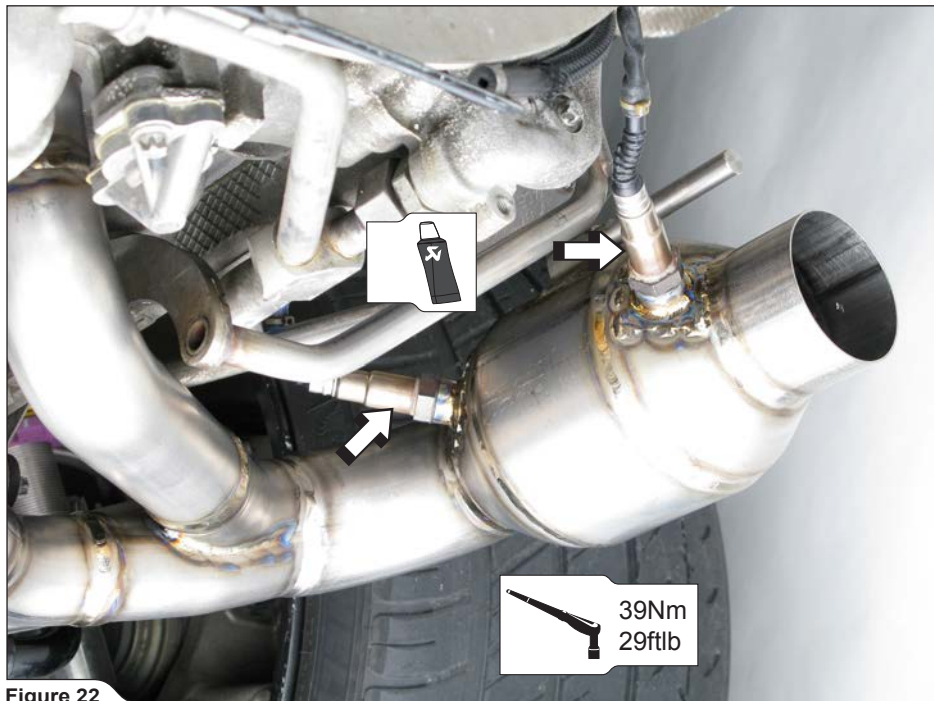
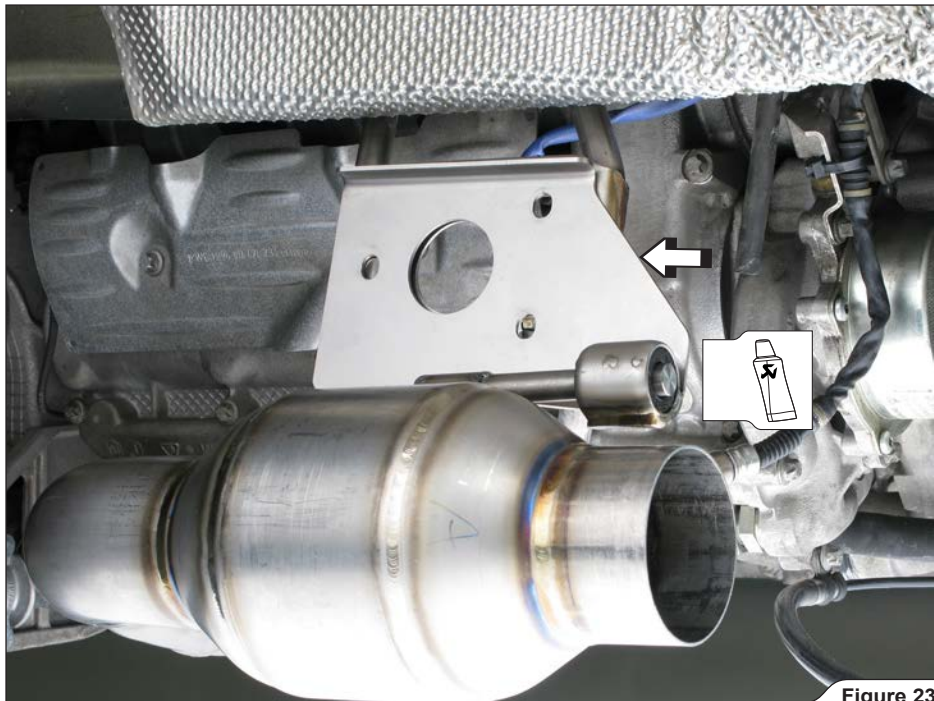

Figure 22

5. **For Evolution:** attach the headers' brackets on both sides of the vehicle (**Figure 23**).
- !** **CAUTION:** do not install the bracket bolts yet!
- ✂** **INSTALLATION TIP:** for easier mounting, lubricate the rubber dampers slightly.



**Figure 23**

6. **For Evolution-Race:** attach and tighten the headers' brackets on both sides of the vehicle. Use Akrapovič M8x16 bolts and M8 nuts (**Figure 24**).

**!** **WARNING:** use anti-seize copper paste on all bolt and nut threads!

**⚠** **INSTALLATION TIP:** for easier mounting, lubricate the rubber dampers slightly.

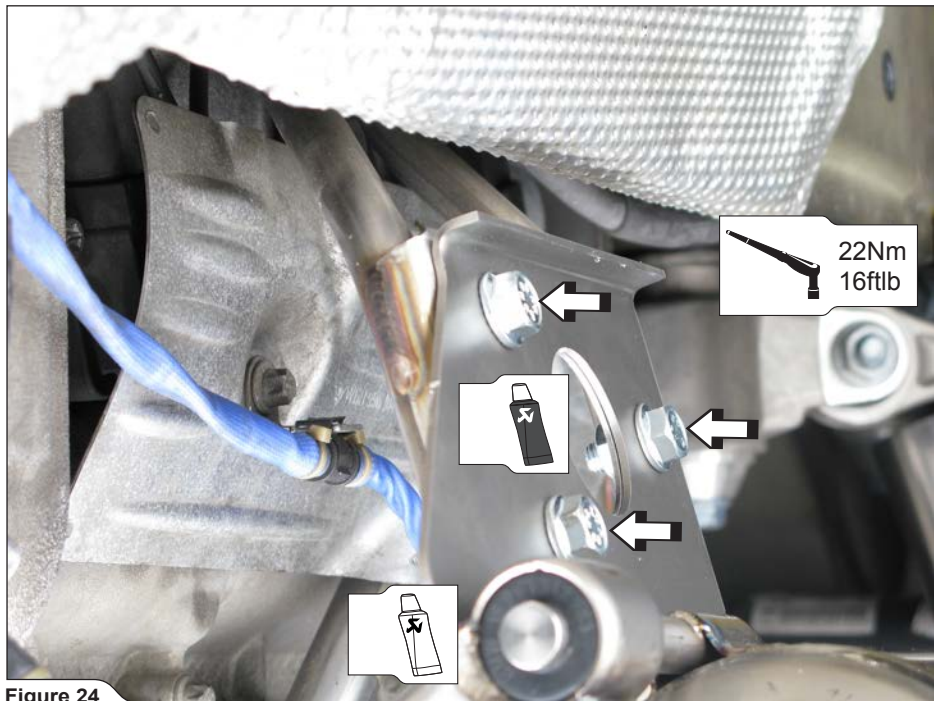

Figure 24

7. **For Evolution and SlipOn-Race:** coat the bolts and interior of metal clamps with anti-seize copper paste (black tube) and correctly install the metal clamps onto the side-muffler (Figure 25). Perform the process on both side-mufflers.

**W** **INSTALLATION TIP:** for easier mounting, untighten the marked bracket nut on both side mufflers.



Figure 25



8. **For Evolution and SlipOn-Race:** tighten the side-mufflers on both sides of the vehicle, using Akrapovič M8x16 bolts and M8 nuts (**Figure 26**).

! **WARNING:** use anti-seize copper paste on all bolt and nut threads!

✂ **INSTALLATION TIP:** coat the interior of the side mufflers inlet and outlet bushes with ceramic grease (white tube).

! **CAUTION:** For SlipOn-Race only: insert the spacers between side mufflers' brackets and stock brackets!

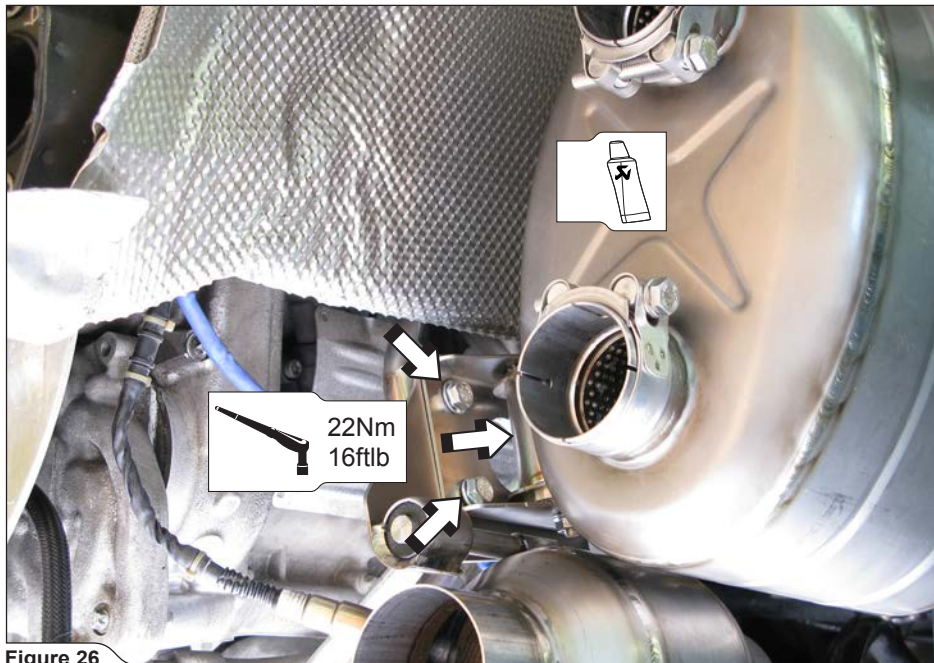

Figure 26

9. **For Slip-On, Evolution and SlipOn-Race:** assemble Akrapovič central muffler clamps, gaskets, flanges and nuts correctly; hand tighten bolts and nuts (**Figure 27**).
- ! **WARNING:** use anti-seize copper paste on all nut and bolt threads (especially on both clamp bolts)!



Figure 27



10. **For Sports Cup and Evolution-Race:** assemble Akrapovič central muffler clamps, gaskets, side mufflers blocks, flanges and nuts correctly; hand tighten bolts and nuts (**Figure 28**).
- ! **WARNING:** use anti-seize copper paste on all nut and bolt threads (especially on both clamp bolts)!



Figure 28

11. **For Evolution and SlipOn-Race:** unscrew and remove the vacuum cylinder from stock link pipe (Figure 29). Repeat the process on both sides.

! **WARNING:** be careful not to damage the vacuum cylinders during this process!

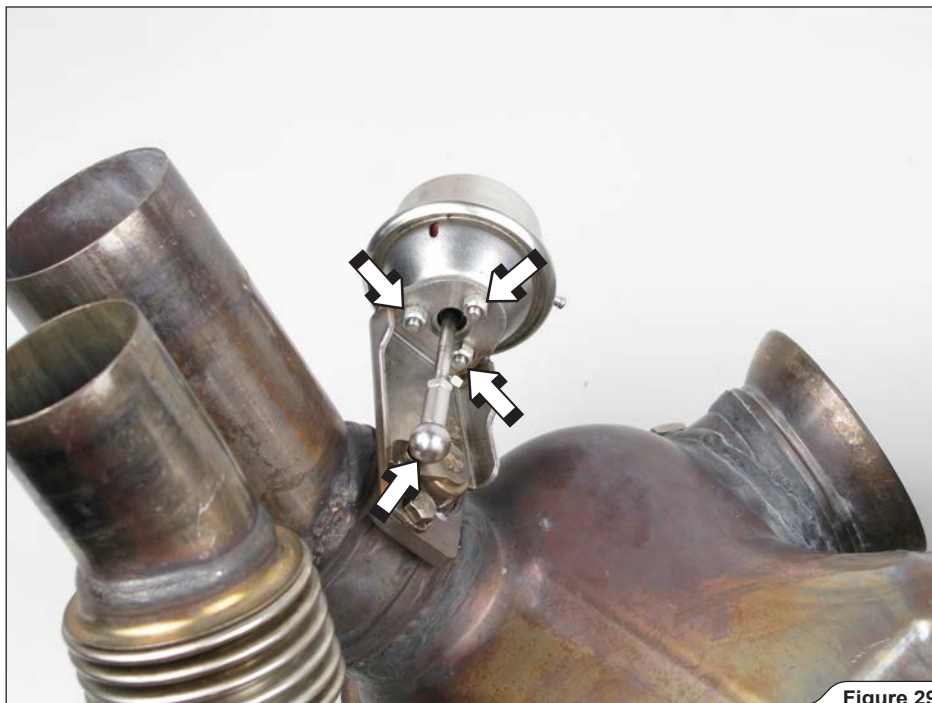

Figure 29

12. **For Evolution and SlipOn-Race:** attach the Akrapovič metal clamps (**For Evolution only!**) onto link pipes as shown (**Figure 30**). Assemble the Akrapovič vacuum cylinder brackets (using Akrapovič M6x12 bolts) and vacuum cylinders (using stock nuts) onto Akrapovič link pipes as shown (**Figure 30**).

! **CAUTION:** orient the vacuum cylinders exactly as shown!

! **WARNING:** use anti-seize copper paste on all nut threads and vacuum actuator ball joints!

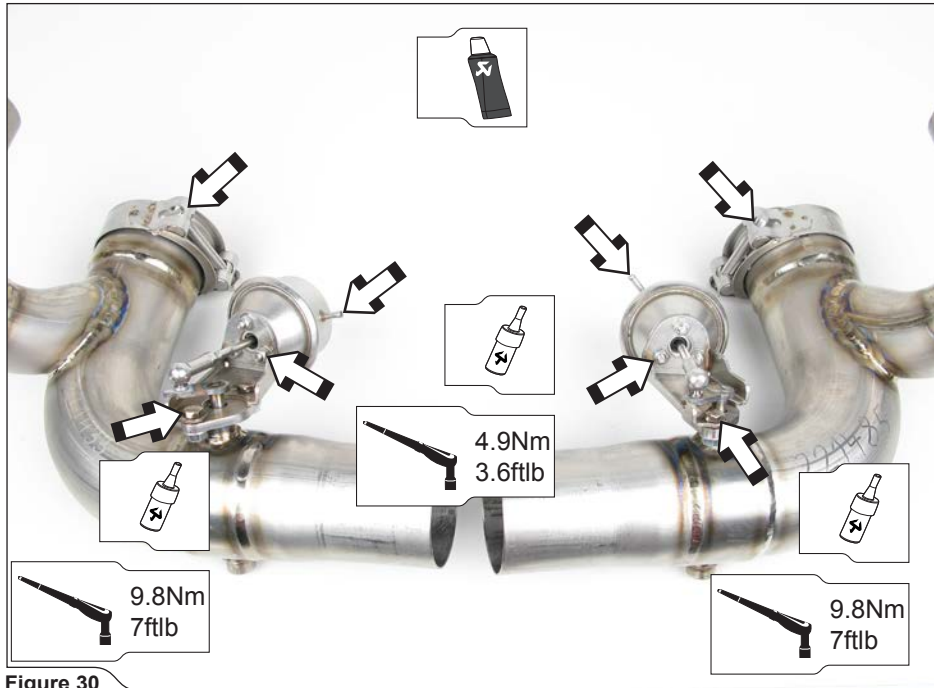

Figure 30

13. **For Evolution and SlipOn-Race:** insert the link pipes into the central muffler (**Figure 31**). Repeat the process on both sides the muffler.

**✂ INSTALLATION TIP:** coat the interior of marked link pipe inlet bush with ceramic grease (white tube).



Figure 31

14. **For Evolution-Race:** insert the link pipe into the central muffler and attach the Akrapovič metal clamp (Figure 32). Repeat the process on both sides the muffler.

**✂ INSTALLATION TIP:** coat the interior of marked link pipe inlet bush with ceramic grease.

**! WARNING:** use anti-seize copper paste on all nut and bolt threads!



Figure 32

15. **For Evolution and SlipOn-Race:** hang the central muffler and simultaneously insert the link pipes into the side mufflers and onto the headers (**Figure 33**).

! **WARNING:** make sure that all link pipes are completely joint with bushes - use rubber mallet, if necessary, to tap the connections into place!



**Figure 33**

16. For Slip-On, Sports Cup, Evolution, Evolution-Race and SlipOn-Race: hang, center and align (see the reference measurement in figure) the muffler (Figure 34). Tighten the muffler clamps to a specified torque.

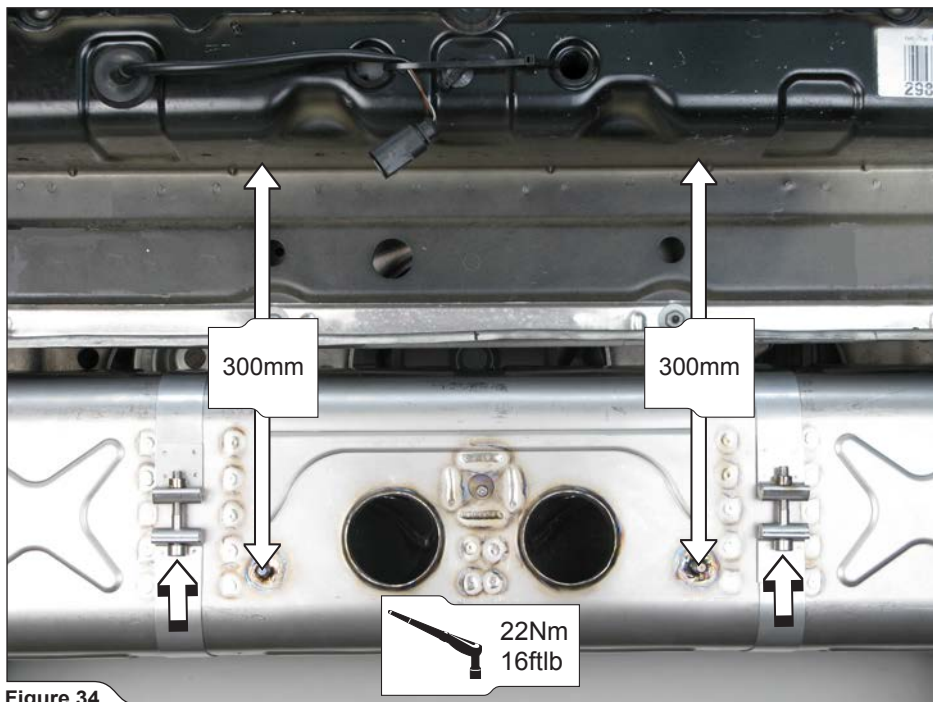

Figure 34

17. **For Slip-On:** install both stock side mufflers using stock nuts. Tighten the nuts to a specified torque (**Figure 35**).

! **WARNING:** use anti-seize copper paste on all nut threads!

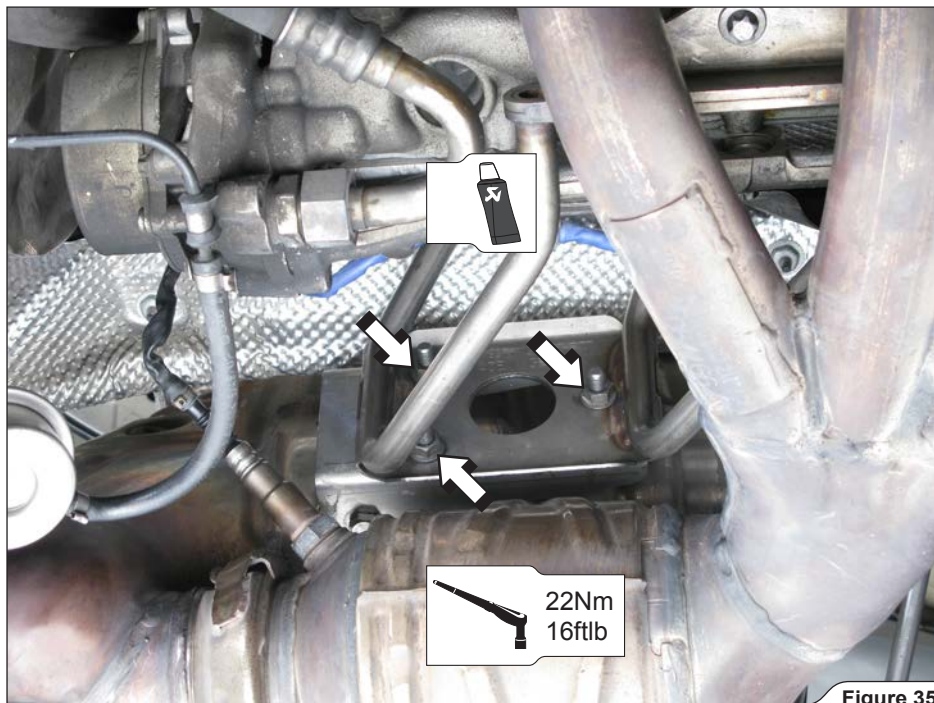

Figure 35



18. **For Slip-On:** tighten all M8 nuts on Akrapovič muffler flanges and stock clamp to a specified torque (**Figure 36**).

! **WARNING:** use anti-seize copper paste on stock clamp bolt threads!

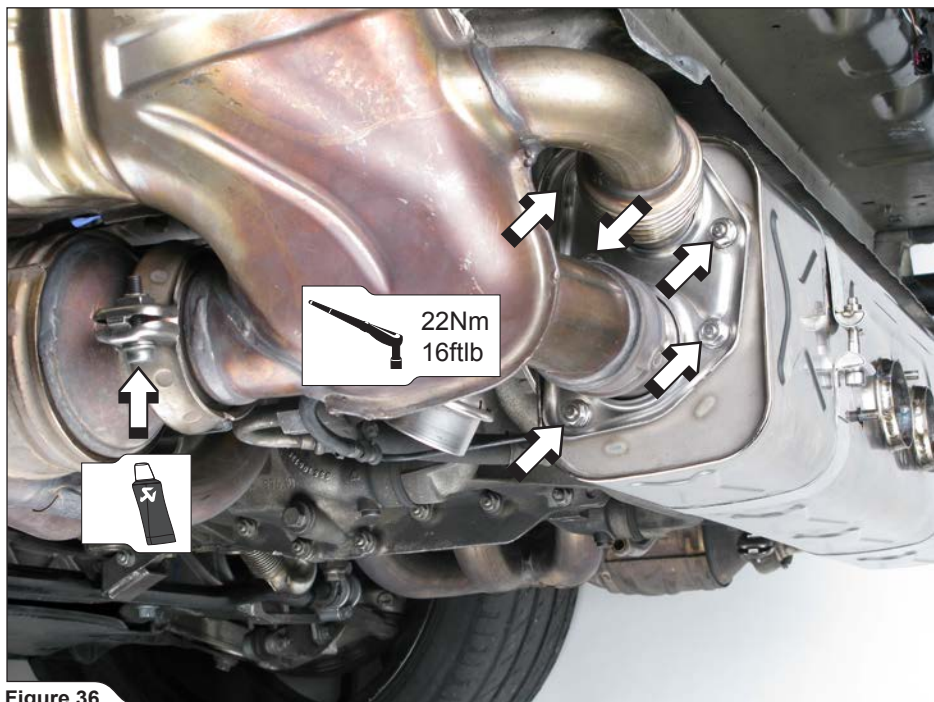

Figure 36

19. For Evolution and SlipOn-Race: attach the four additional springs, as shown (Figure 37, 38).

! **WARNING:** make sure, that clamp bolts are in horizontal position and that springs are sufficiently tense!

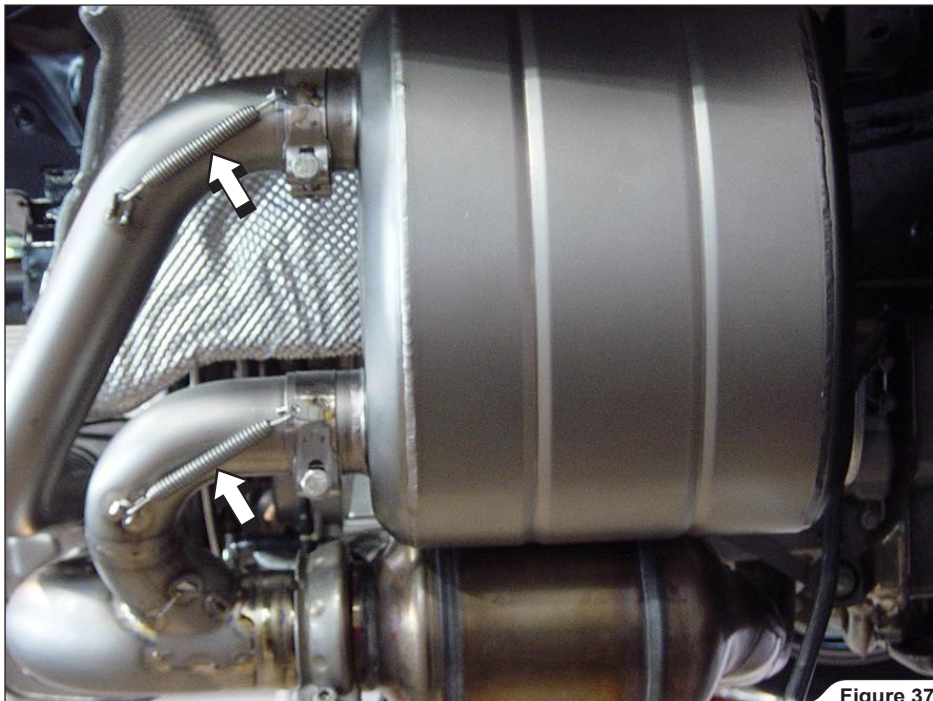

Figure 37

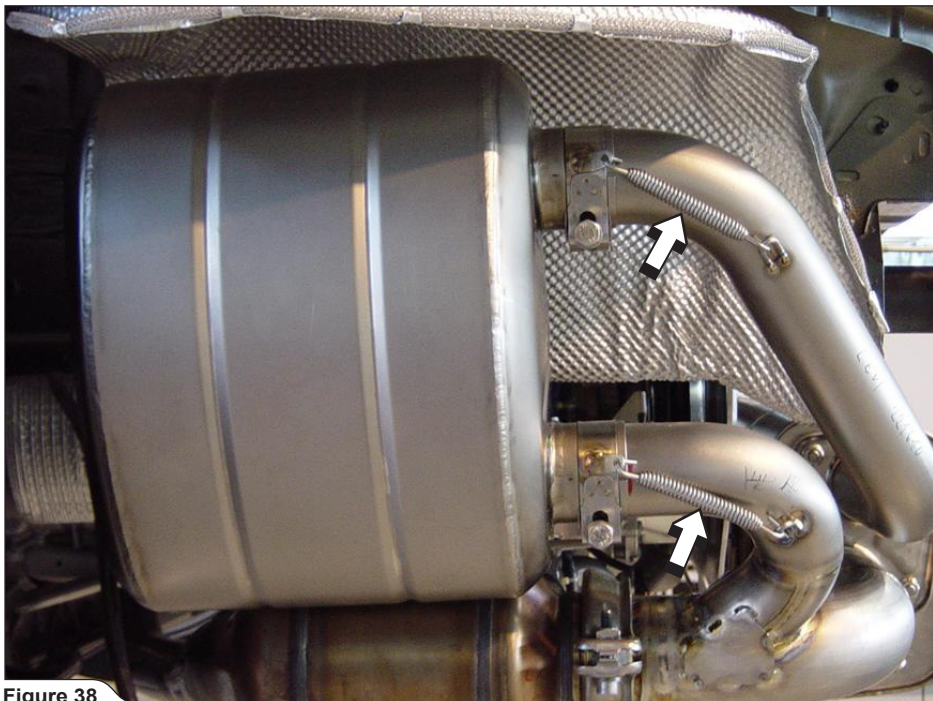
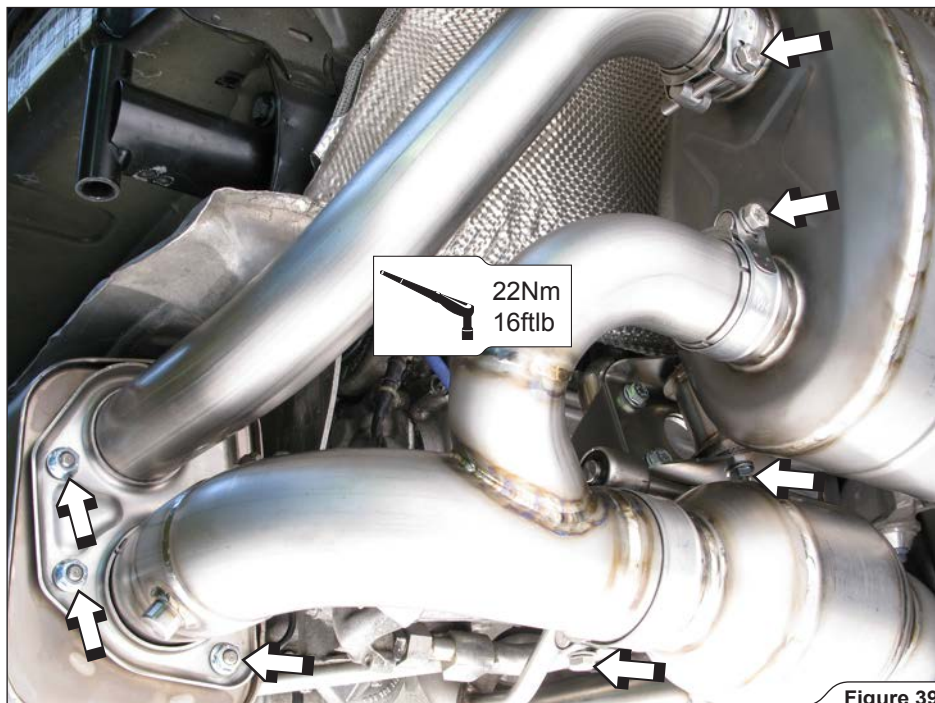

Figure 38

20. **For Evolution and SlipOn-Race:** tighten all M8 nuts and bolts on Akrapovič central muffler flanges, metal clamps and side mufflers bracket to a specified torque (**Figure 39**). Repeat the process on both sides of the vehicle.



21. For Slip-On and Evolution and SlipOn-Race: attach the vacuum tubes to vacuum cylinders (Figure 40).

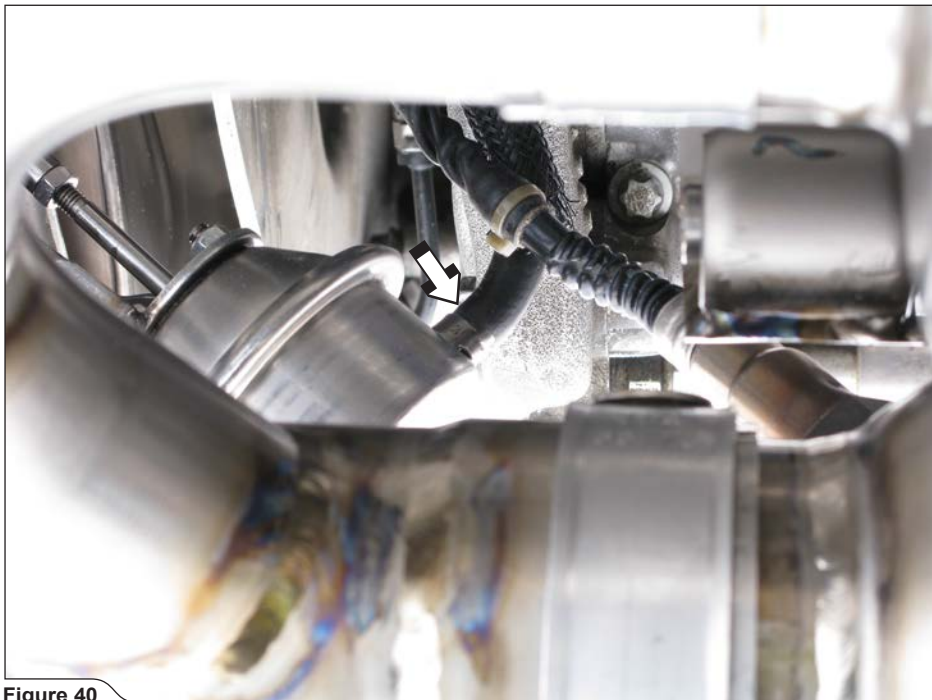
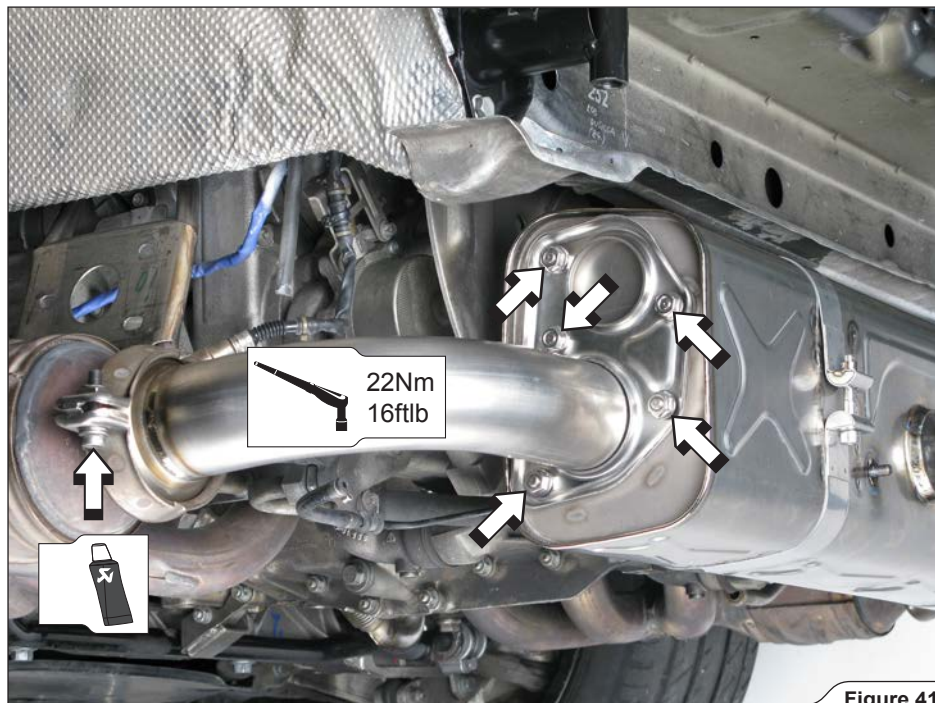

Figure 40



22. **For Sports Cup:** align the link pipes and tighten all M8 nuts on Akrapovič muffler flanges and stock clamps to a specified torque (**Figure 41**).



23. **For Evolution-Race:** align the link pipes and tighten all M8 nuts on Akrapovič muffler flanges and bolts on metal clamps to a specified torque (**Figure 42**).

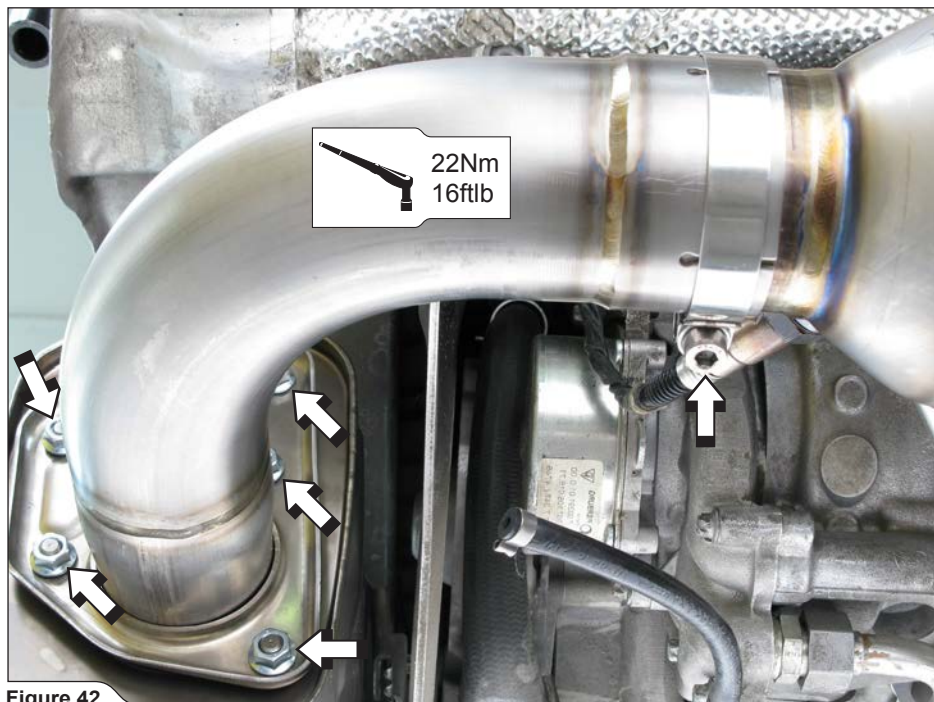

Figure 42



24. **For Sports Cup and Evolution-Race:** Install the plastic plugs (supplied in the Akrapovič installation kit) into the vacuum cylinder tubes (both tubes!) and secure the plugs with plastic ties; cut away excess tie (**Figure 43**).

! **WARNING:** make sure that vacuum tubes are secured in such way that they don't touch any hot or moving parts of the vehicle!



Figure 43

25. **For Tail Pipe:** position the Akrapovič tail pipe piece onto the stock muffler; correctly assemble and hand tighten the three M8 nuts and two centering washers. Center the tail piece in respect to rear bumper and tighten the nuts to a specified torque (**Figure 44**).

! **WARNING:** use anti-seize copper paste on all nut threads!



Figure 44

26. **For Slip-On, Sports Cup, Evolution, Evolution-Race and SlipOn-Race:** position the Akrapovič tail pipe piece onto the muffler; correctly assemble and hand tighten the three M8 nuts and two centering washers. Center the tail piece in respect to rear bumper and tighten the nuts to a specified torque (**Figure 45**).

**! WARNING:** use anti-seize copper paste on all nut threads!

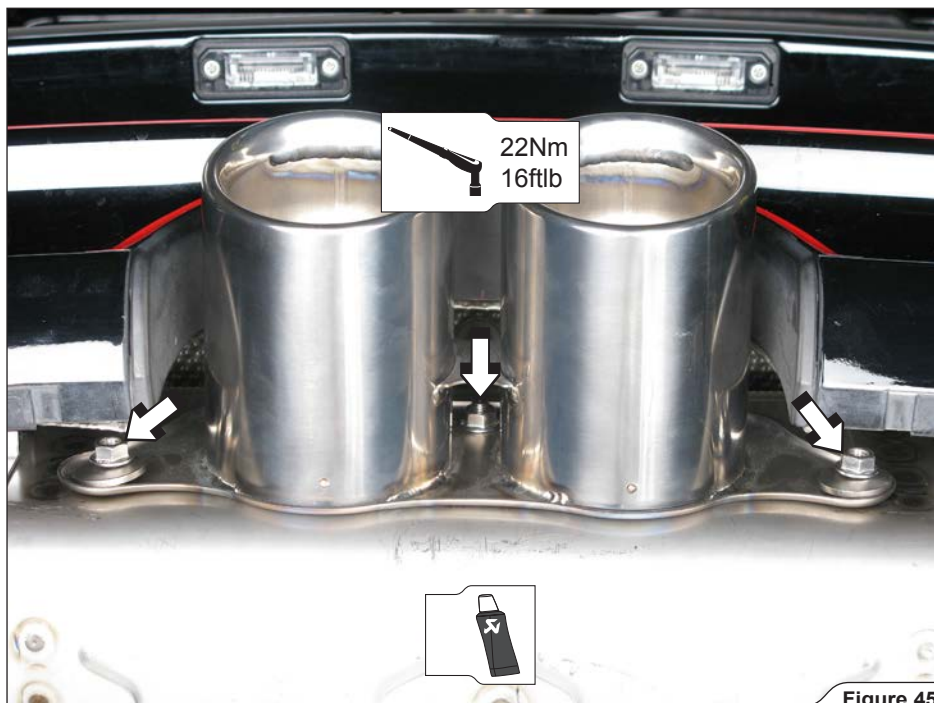

### Final installation:

27. **For Slip-On, Sports Cup, Evolution and Evolution-Race:** replace all of the dismantled stock parts in the reverse order from the order in which they were removed.

**!** **WARNING: check vehicle manufacturer manual for tightening torques (for dismantled stock parts)!**

**!** **WARNING: make sure all the nuts and bolts are sufficiently tightened. In case the exhaust system touches the cowl or other parts, repeat the adjustment of the exhaust system or contact your authorized dealer.**

### **MAINTENANCE OF THE AKRAPOVIČ EXHAUST SYSTEM**

1. Clean the titanium exhaust components with a multi-purpose spray lubricant (WD-40 or equivalent), carbon fiber exhaust components with soft and dry cloth and stainless steel components with soft cloth sprayed with contact cleaner, then wipe with soft and dry cloth. A change in the color of the exhaust system is normal due to high temperatures.
2. Periodically make sure all the bolts and springs are sufficiently tight.

**!** **WARNING: clean all exhaust components before the first start of the engine or the stains will burn onto the surfaces!**

**!** **IT IS NORMAL IF WHITE SMOKE COMES OUT OF THE MUFFLER ON FIRST OPERATION.**

**!** **DO NOT STAND BEHIND THE MUFFLER ON FIRST OPERATION.**

**!** **DO NOT USE AUTOMOTIVE WHEEL CLEANERS OR ANY CLEANING PRODUCTS WHICH CONTAIN ACIDIC ADDITIVES TO CLEAN AKRAPOVIČ EXHAUST SYSTEMS.**

## **INSTALLATION OF THE AKRAPOVIČ CARBON FIBER SET (3.8L GT3/GT3 RS ONLY!):**

**!** **WARNING:** please note, that rear carbon fiber lip is mandatory. If you don't use the carbon fiber kit on 3.8L model, the Akrapovic company can't take responsibility for damages occurring do to lack off clearance between rear bumper (muffler heatshield) and central muffler!

1. Unscrew the marked bolts and remove stock spoiler off the rear bumper (**Figure 46, 47**).



**Figure 46**



Figure 47

2. Drill the nine 6.5 mm holes and cut off the marked black metal borders, using templates from Akrapovič installation kit (**Figure 48, 49**).

**!** **WARNING:** be very precise, when marking the drill holes, using templates!  
**✂** **INSTALLATION TIP:** use air saw or equivalent, to cut off the bumper borders.



**Figure 48**





**Figure 49**

3. Install the nine Akrapovič M5 press on nuts onto the carbon fiber lip (**Figure 50**).

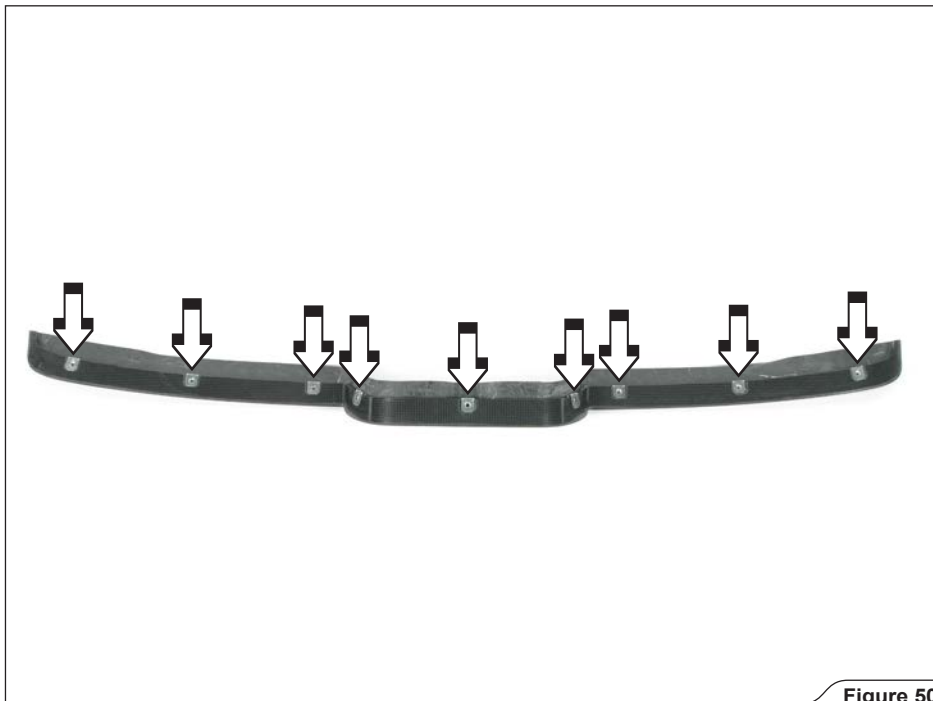

**Figure 50**

4. First hand tighten the carbon fiber lip onto the rear bumper, center the lip in respect to the bumper and then tighten the bolts to a specified torque (**Figure 51**).

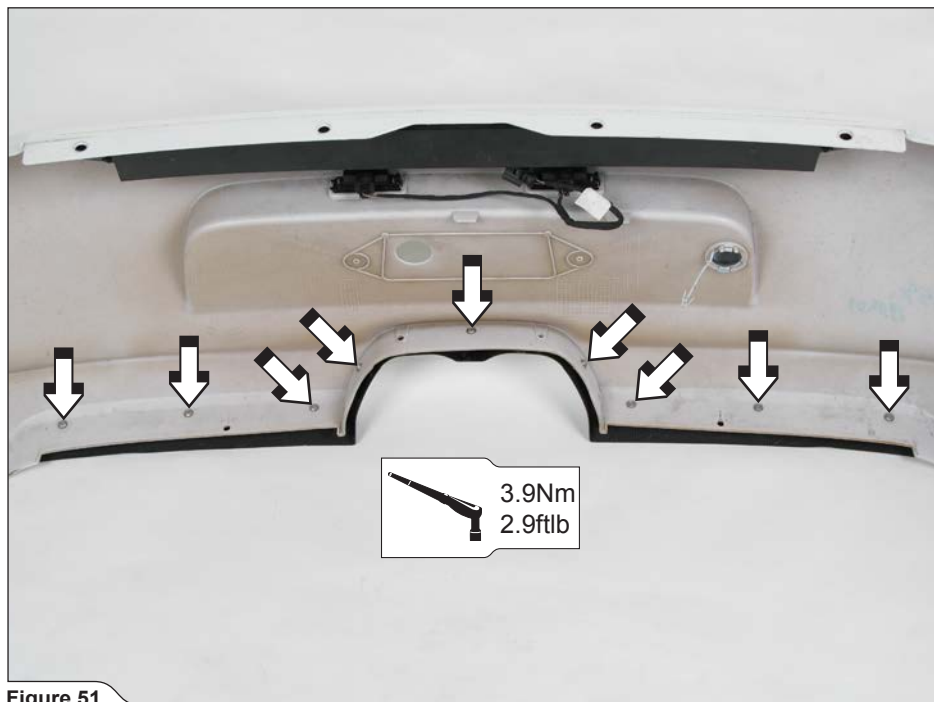

Figure 51

5. Unscrew the two stock rear bumper brackets off the stock exhaust heat shield. Displace the marked stock press on Akrapovič brackets, as shown (Figure 52).



Figure 52

6. Tighten the Akrapovič brackets onto the muffler heatshield, using stock bolts. Slide the Akrapovič M6 press on nuts on the other side of the brackets (**Figure 53**).



**Figure 53**

7. After installation of the muffler heatshield and rear bumper onto the vehicle, tighten the bumper onto brackets, using Akrapovič M6x16 bolts and washers. Bend the edge of the heatshield so, that the clearance between heatshield and muffler is at least 10mm (**Figure 54**).

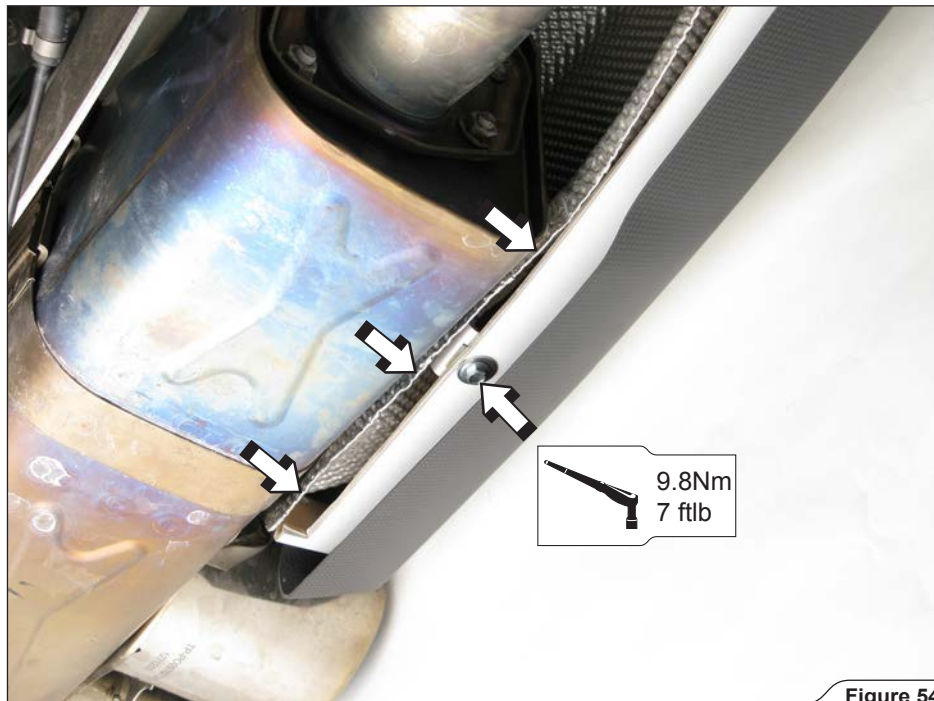
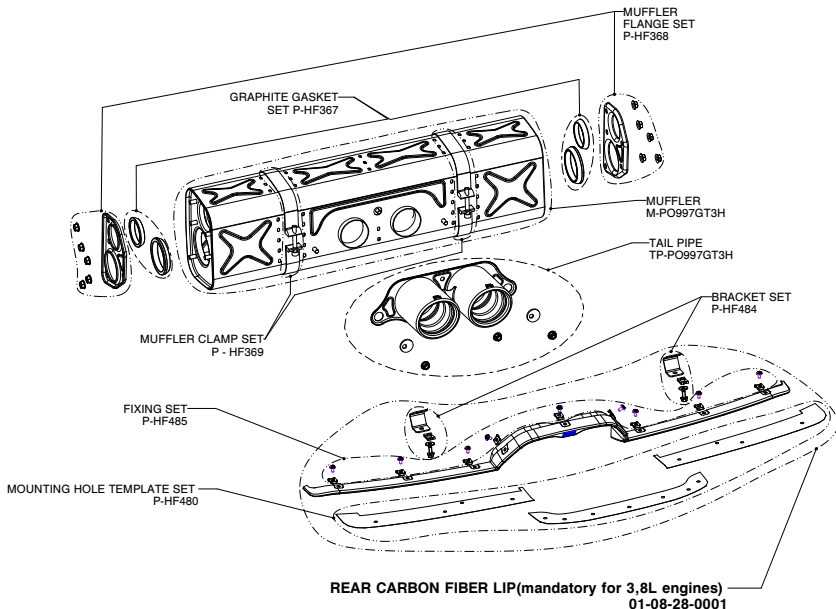

**Figure 54**





**PORSCHE 911 GT3/RS 3.6L & 3.8L, type 997 Titanium exhaust system / "SLIP-ON HOMOLOGATED" version**  
**Product code: MTP-PO997GT3H**



**PORSCHE 911 GT3/RS 3.6L & 3.8L, type 997 Titanium exhaust system / "SPORTS CUP" version**  
**Product code: S-PO997GT3CUP**

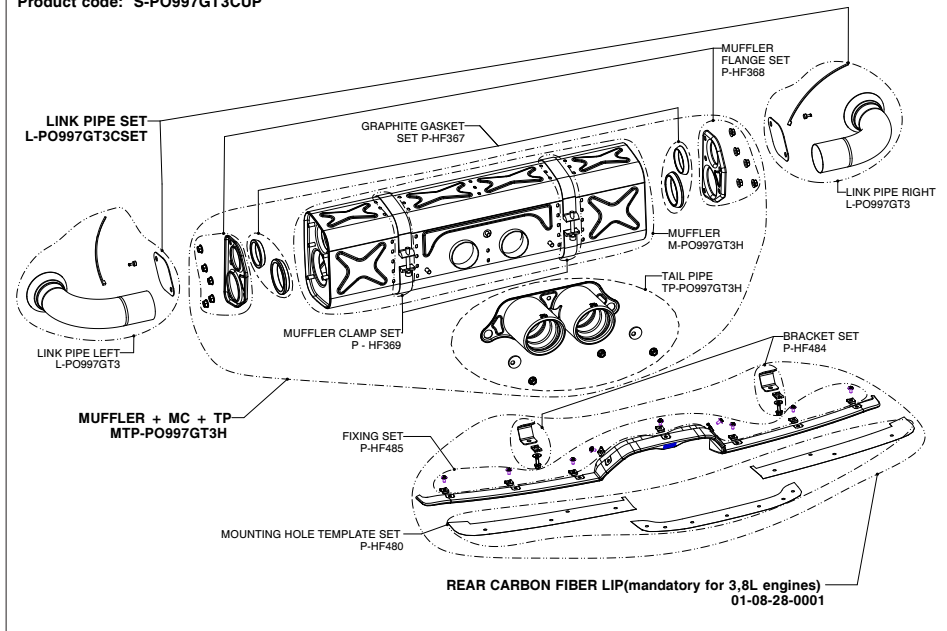

**PORSCHE 911 GT3/RS 3.6L/3.8L, type 997 Titanium exhaust system / "SO RACE"**

**Product code: S-PO997GT3SO2-R 112489**

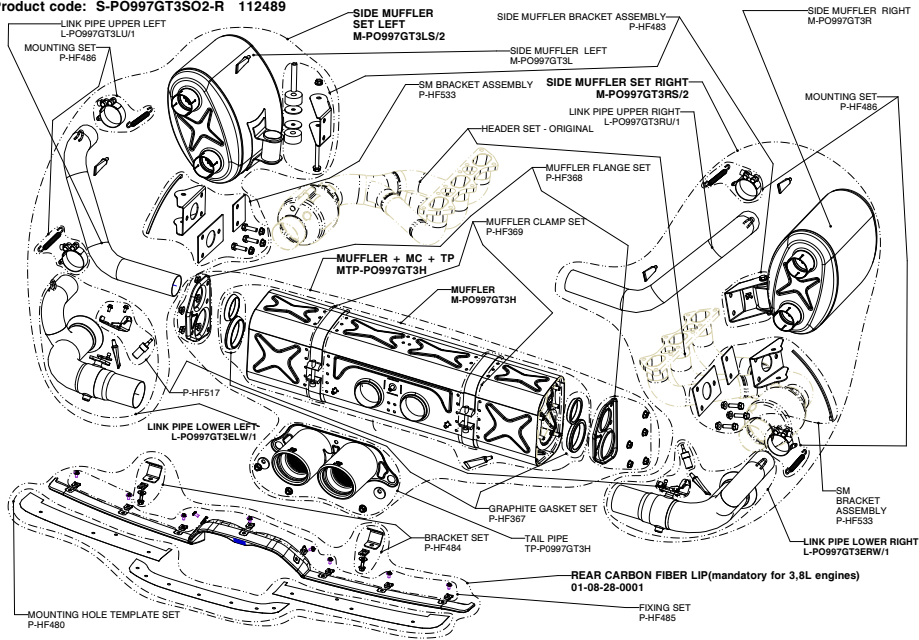

**PORSCHE 911 GT3/GT3 RS 3.6L type 997 Titanium exhaust system / "EVOLUTION" version**  
**Product code: S-PO997GT3E**

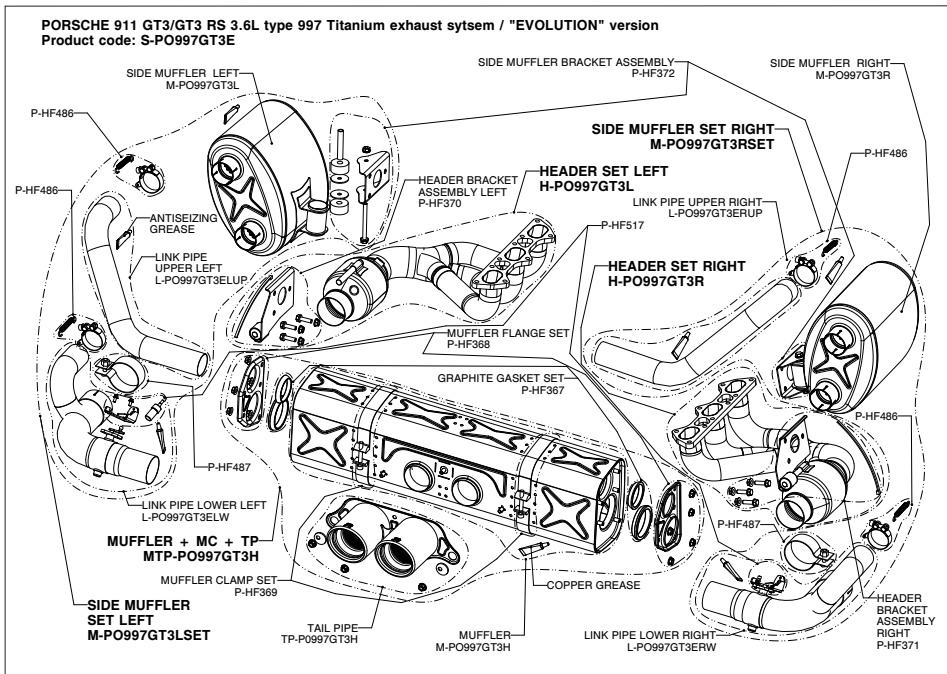

**PORSCHE 911 GT3/RS 3.8L, type 997 Titanium exhaust system / "EVOLUTION" version**  
**Product code: S-PO997GT3FLE**

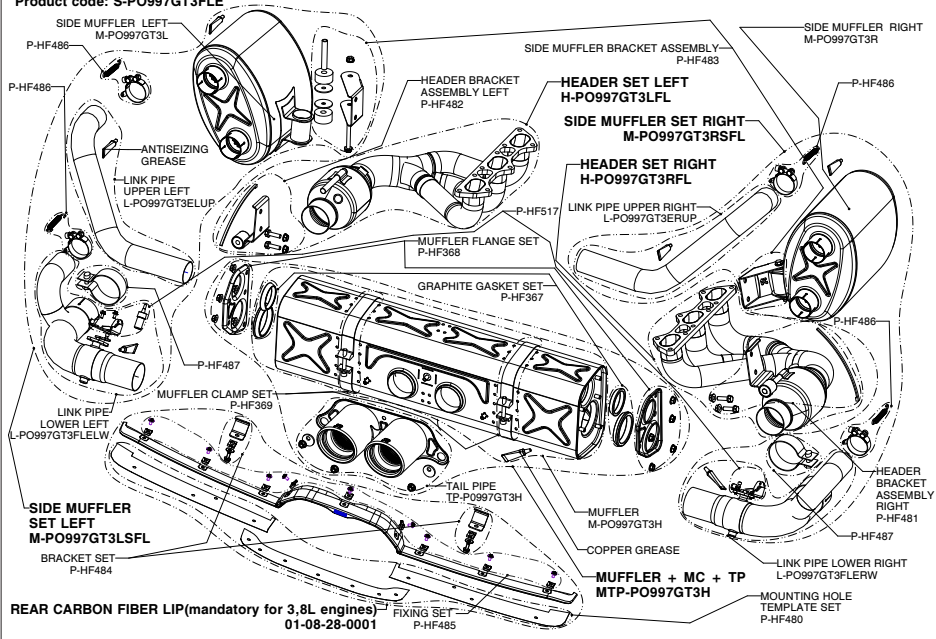

**PORSCHE 911 GT3/RS 3.6L, type 997 Titanium exhaust system / "EVOLUTION - RACE" version**  
**Product code: S-PO997GT3ER**

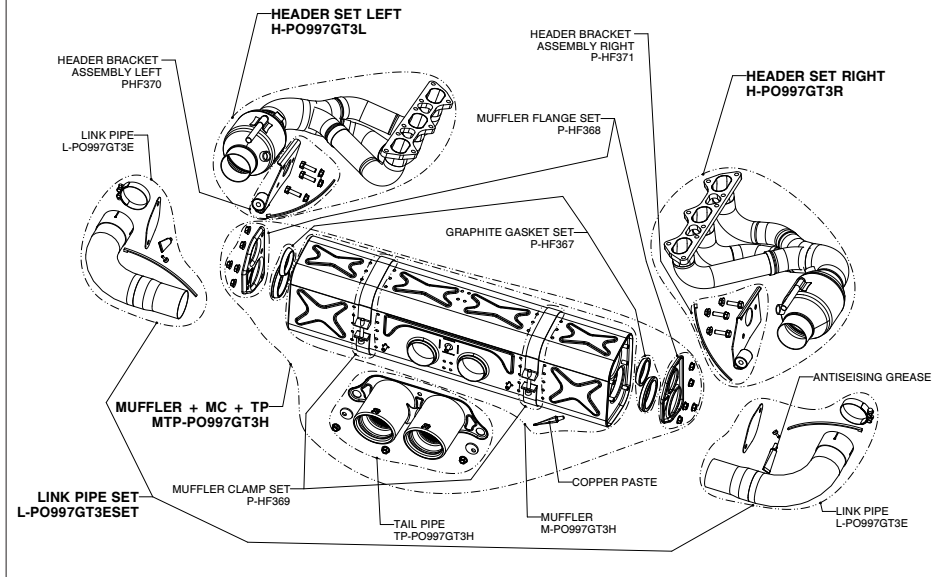

**PORSCHE 911 GT3/RS 3.8L, type 997 Titanium exhaust system / "EVOLUTION - RACE" version**  
**Product code: S-PO997GT3FLER**

