

**Air Lift**<sup>™</sup>  
**PERFORMANCE**

# Kit 78614

Lexus XE10  
(IS200/IS300/Altezza)

***Rear Application***

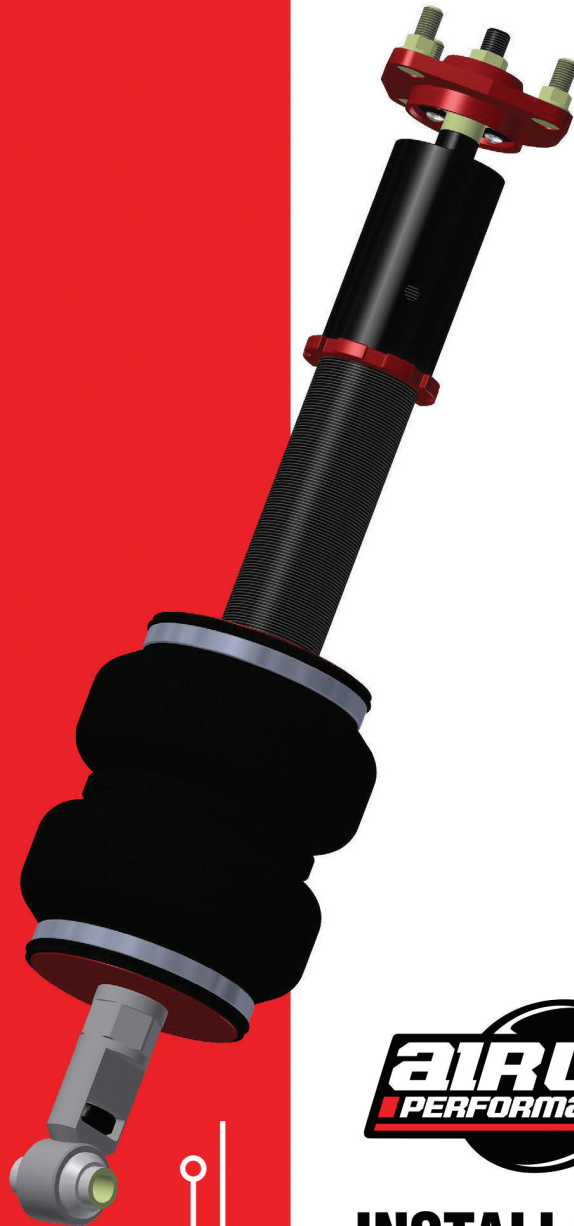

## INSTALLATION GUIDE

For maximum effectiveness and safety, please read these instructions completely before proceeding with installation.

*Failure to read these instructions can result in an incorrect installation.*

PERFORMANCE SUSPENSION PARTS

## Introduction

The purpose of this publication is to assist with the installation, maintenance and troubleshooting of this Lexus XE10 Platform Performance kit.

It is important to read and understand the entire installation guide before beginning installation or performing any maintenance, service or repair. The information includes a hardware list, step-by-step installation information, maintenance tips, safety information and a troubleshooting guide.

### NOTATION EXPLANATION

Hazard notations appear in various locations in this publication. Information which is highlighted by one of these notations must be observed to help minimize risk of personal injury or possible improper installation which may render the vehicle unsafe. Notes are used to help emphasize areas of procedural importance and provide helpful suggestions. The following definitions explain the use of these notations as they appear throughout this guide.

 **DANGER**

INDICATES IMMEDIATE HAZARDS WHICH WILL RESULT IN SEVERE PERSONAL INJURY OR DEATH.

 **WARNING**

INDICATES HAZARDS OR UNSAFE PRACTICES WHICH COULD RESULT IN SEVERE PERSONAL INJURY OR DEATH.

 **CAUTION**

INDICATES HAZARDS OR UNSAFE PRACTICES WHICH COULD RESULT IN DAMAGE TO THE MACHINE OR MINOR PERSONAL INJURY.

### NOTE

*Indicates a procedure, practice or hint which is important to highlight.*

### IMPORTANT SAFETY NOTICES

The installation of this kit does not alter the Gross Vehicle Weight Rating (GVWR) or payload of the vehicle. Check your vehicle's owner's manual and do not exceed the maximum load listed for your vehicle.

**Gross Vehicle Weight Rating:** The maximum allowable weight of the fully loaded vehicle (including passengers and cargo). This number — along with other weight limits, as well as tire, rim size and inflation pressure data — is shown on the vehicle's Safety Compliance Certification Label.

**Payload:** The combined, maximum allowable weight of cargo and passengers that the vehicle is designed to carry. Payload is GVWR minus the Base Curb Weight.

 **WARNING**

DO NOT INFLATE AIR SPRINGS WHILE OFF OF THE VEHICLE. DAMAGE TO ASSEMBLY MAY RESULT AND VOID WARRANTY.

 **CAUTION**

DO NOT WELD TO, OR MODIFY PERFORMANCE STRUTS/SOCKS IN ANY WAY. DAMAGE TO UNIT MAY OCCUR AND WILL VOID WARRANTY.

# Installation Diagram

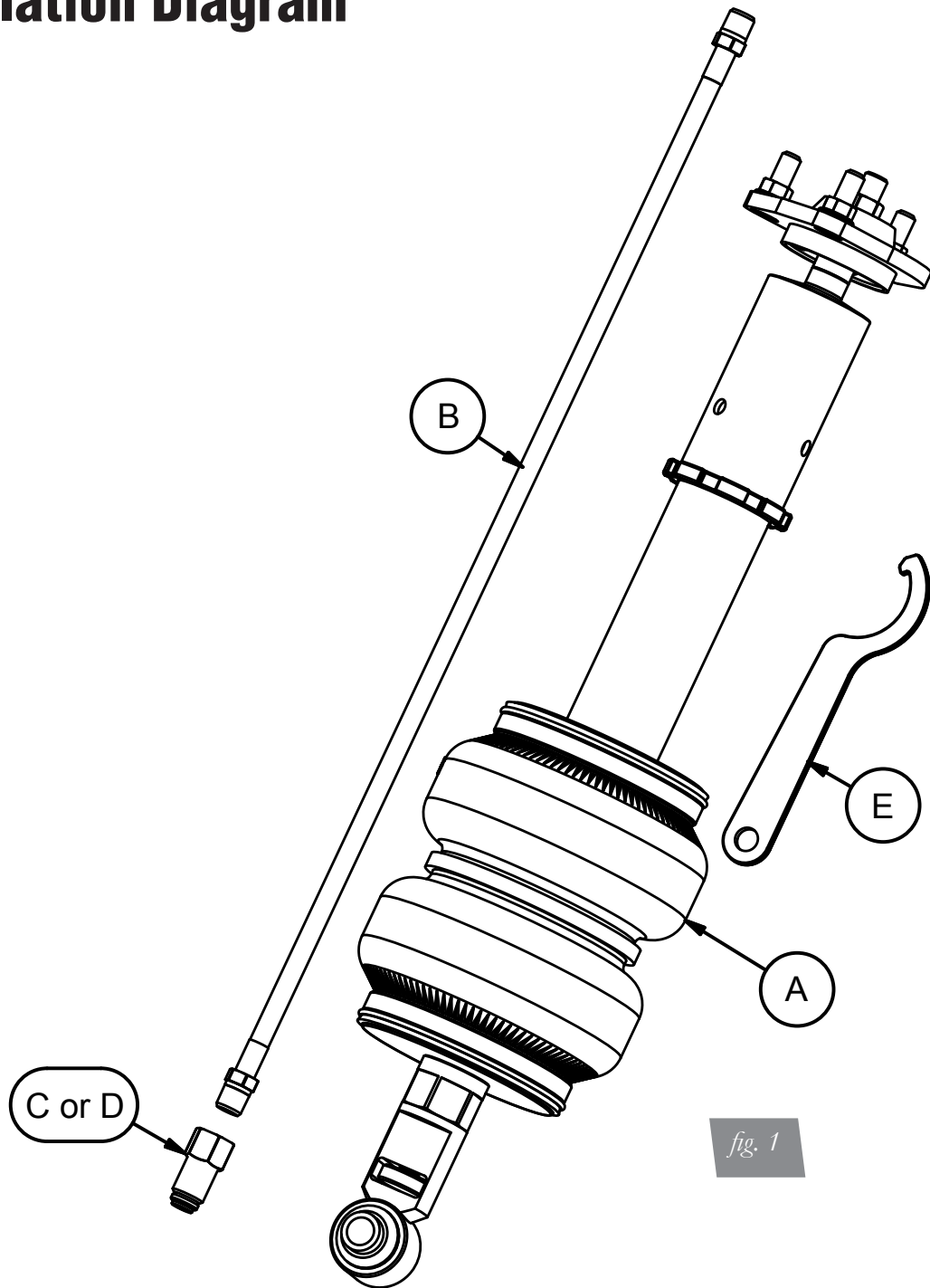

fig. 1

## HARDWARE LIST

Item	Part #	Description.....	Qty
A	35295	Shock, Lexus XE10 Platform Rear .....	2
B	20997	Leader Hose, 1/4" ID.....	2
C	21810	Union, 1/4"FNPT X 1/4" PTC, DOT .....	2
D	21987	Union, 1/4"FNPT X 3/8" PTC, DOT.....	2
E		Spanner Wrench.....	1

# Installing the Air Suspension

## PREPARING THE VEHICLE

1. Elevate and support the vehicle with a hoist or jack stands.
2. Remove the rear tire and support the hub assembly.



## REMOVING THE REAR SHOCK

1. Unbolt the stabilizer bar end link/headlight alignment bracket, shock eye and cam bolt from the lower control arm (figs. 3 and 4). Make certain to not over extend the headlight alignment linkage/sensor. Detach the lower control arm from the hub assembly (fig. 5).

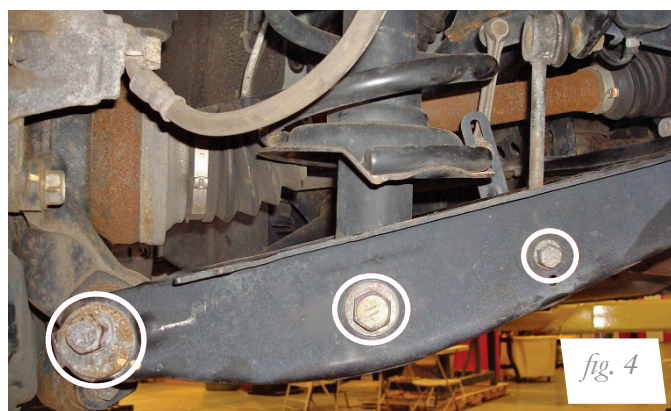

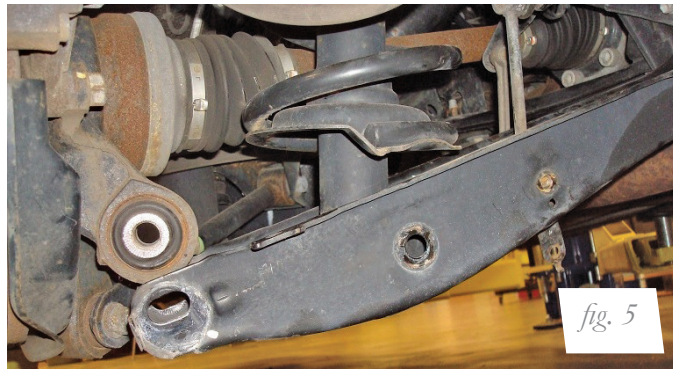

2. Remove the two lower bolts from the upper mount bracket (fig. 6).

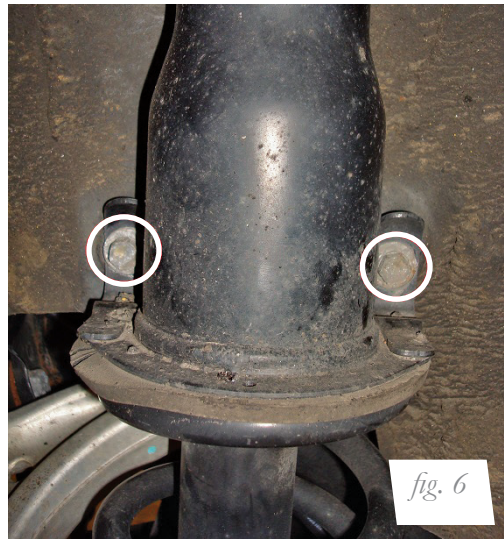

3. Within the luggage compartment, remove the trim and upper shock mount nuts behind the trim (fig. 7).

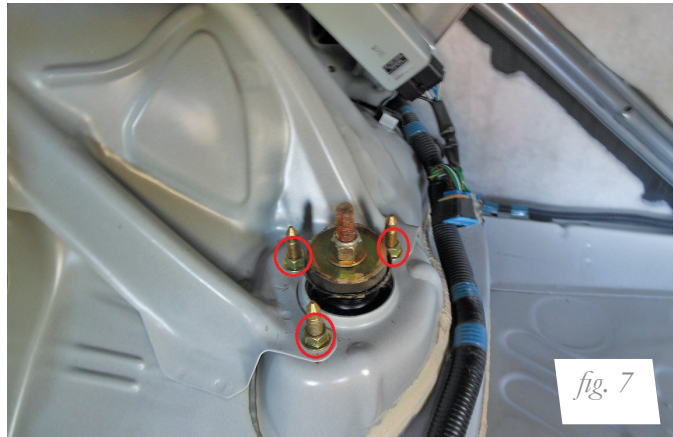

4. Remove the shock from the vehicle (fig. 8).



## AIR SUSPENSION INSTALLATION

1. Begin by installing the leader line into the air spring (fig. 9). Apply thread sealant to the threads of the leader hose. Tighten the appropriate fitting to the airline 1 ¼ turns beyond hand tight. Tighten the leader line into the air spring 1 ¼ turns beyond hand tight.

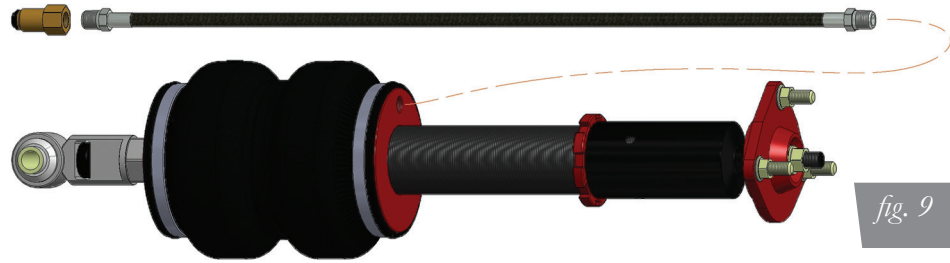

*fig. 9*

2. Insert the shock into the shock pocket of the vehicle (fig. 10a) and attach the three upper mount nuts (fig. 10b). Torque to 64Nm (47lbs ft).



*fig. 10a*



*fig. 10b*

3. Reinstall the stabilizer bar end link/headlight alignment bracket, shock eye and cam bolt from the lower control arm (fig. 11). Do not torque at this time.



*fig. 11*

4. Fully compress the suspension using a jack. With the suspension compressed, review the best routing for the leader hose that is clear of all suspension components and axle. Routing should also allow for the suspension to extend without kinking or pulling the line tight or rubbing on other components. Check clearances to all other components.
4. With the suspension fully compressed, take a measurement from the fender to some reference point – typically the center of the axle. Record this measurement as Max Compression.
6. Cycle the suspension to Max Extension and record the measurement from the same reference points.
7. Add ME and MC then divide by 2. Set the suspension to this point. This position will give 50% stroke in either direction and is a starting point for ride height (fig. 12).

**Formula for Calculating Ride Height**

$$(ME+MC) \div 2 = \text{MID STROKE}$$

*fig. 12*

12. With the suspension at this position, loosen, then re-torque the lower control arm bolts to manufacturer's specifications (Table 1).

Torque Specifications		
Location	Nm	lb-ft
Upper mount to chassis	64	47
Shock eye bolt	110	81
Control arm to hub	110	81
Control arm to sub frame	110	81
Stabilizer link nut and bolt	30	22
Upper control arm bolts to subframe	88	65
Trailing link bolts	75	55
Wheels	103	76

*Table 1*

## DAMPING ADJUSTMENT

The struts in this kit have 30 settings, or “clicks”, of adjustable compression and rebound damping characteristics. Damping is changed using the integrated adjuster knob on the lower eye of the shock (fig. 13).

Turn the adjuster clockwise when viewed from the bottom, and the damping settings are hardened. Turn the adjuster counterclockwise and the damping is softened. Each shock is preset to “-16 clicks”. This means that the shock is adjusted 16 clicks away from full stiff. Counting down from full stiff is the preferred method of keeping track of, or setting, damping. This setting was developed on a 2002 Lexus IS300 and may need to be adjusted to different vehicles and driving characteristics.

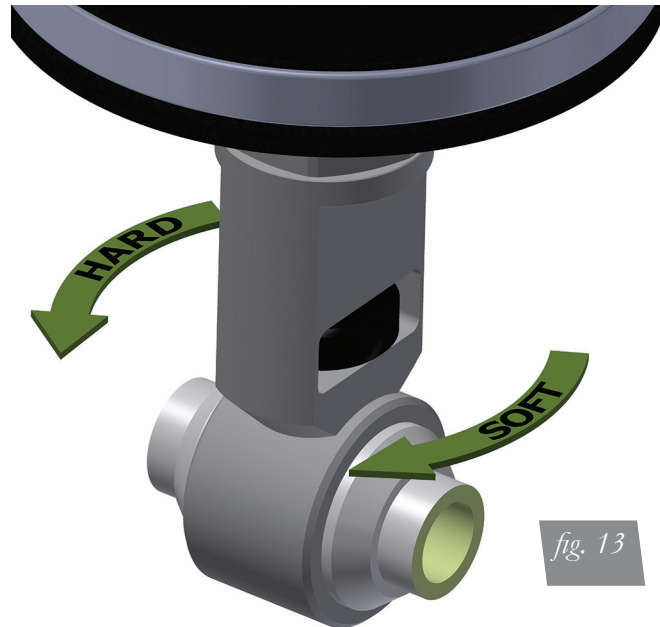

## ALIGNING THE VEHICLE

1. Using the control system, set the vehicle height to the new custom ride height.
2. If the custom ride height is lower than stock, we recommend loosening all pivot points (bolts, nuts) on any control arm, strut arm or radius rod that contains bushings. Once they have been loosened, re-torque to stock specifications.

---

### NOTE

*It may be necessary to cycle the suspension to loosen the bushing up from its mount. This will help re-orient the bushing at its new position based on the custom ride height.*

---



## ADJUSTING EXTENDED OR DROP HEIGHT USING THREADED MOUNT

Your struts/shocks have been pre-set at the factory to provide maximum drop height while maintaining adequate tire clearance to the air spring. If you wish to gain more extended height (lift), which is the same as reducing drop height, or want to lower the chassis further and there is still adjustment available at the upper mount, please use the following procedure:

1. Support the vehicle with jack stands or a hoist at approved lifting points.
2. Remove the wheel.
3. Using the supplied spanner wrench, loosen the lower locking collar (fig. 14).

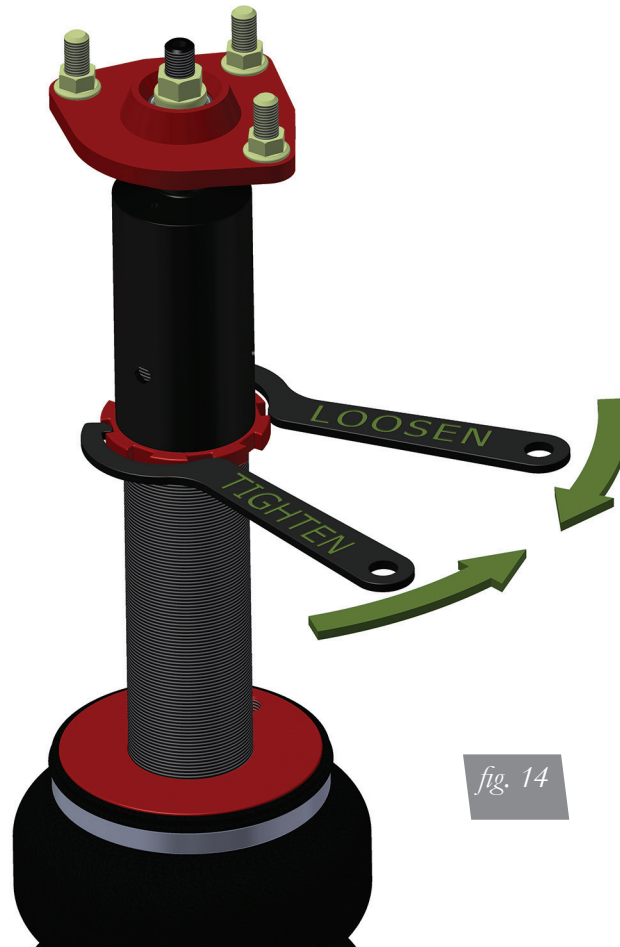

4. Deflate the air spring to 0 PSI on the corner you are adjusting.
5. Disconnect the mount from the suspension.
6. Spin the mount to the desired location.

---

### NOTE

*Not all models will have further drop height available.*

- 
7. Re-install the mount to the suspension and torque the fasteners.
  8. Tighten the locking collar to the mount using significant force.

## CAUTION

WHEN ADJUSTING HEIGHT UPWARDS, MAKE SURE THAT THE STRUT BODY ENGAGES ALL THE THREADS OF THE UPPER MOUNT (FIG. 15). WHEN ADJUSTING DOWNWARDS, MAKE SURE THERE IS ADEQUATE AIR SPRING CLEARANCE TO THE TIRE/WHEEL ASSEMBLY. CLEARANCE MUST BE CHECKED WITH SYSTEM FULLY DEFLATED AS WELL AS FULLY INFLATED TO ENSURE THAT NO RUBBING OCCURS. FAILURE TO MAINTAIN ADEQUATE CLEARANCE CAN RESULT IN AIR SPRING FAILURE AND WILL NOT BE COVERED UNDER WARRANTY.

## CAUTION

DO NOT ADJUST HEIGHT BY SPINNING AIR SPRING ON STRUT! DOING SO MAY CAUSE AN AIR LEAK AND COMPROMISE THE ASSEMBLY.

### FOR STRUTS:

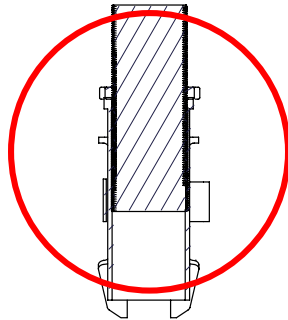
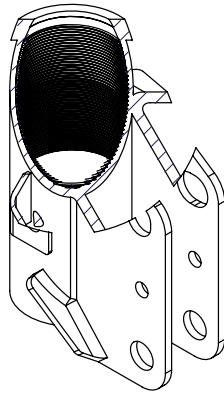

OK, no threads showing.

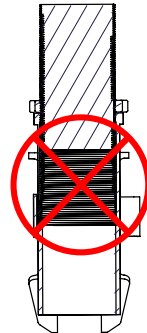

Not OK, threads are showing.

### FOR SHOCKS:

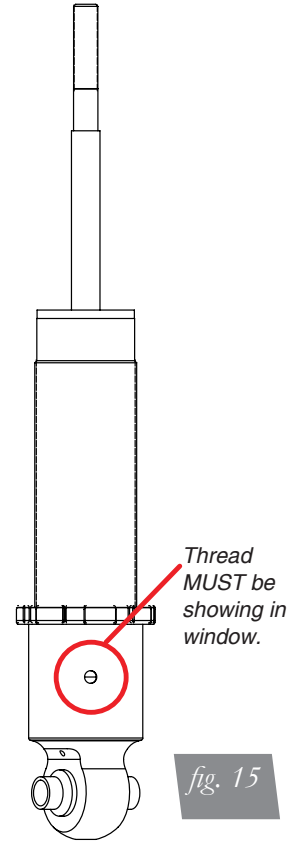

fig. 15