

2019 AIR DESIGN CUSTOM CAR GUIDE

NEW STINGER
GT FEDERATION
BY AIR DESIGN
BEST IN SHOW

BUILD YOUR RIDE



FACTORY OF DREAMS

FULL BODY KITS



OVER 60 MODIFIED CARS TO BUILD YOURS



INSIDE:
REAL PEOPLE
REAL LIFE
REAL CARS



AERODYNAMICS - PERFORMANCE - STYLE - SPARCO ACCESSORIES AND MORE

**AIR★
DESIGN**



**WE LOVE
MODIFIED CARS
EVER SINCE
THEY APPEARED**



**BUILD
YOUR
RIDE**

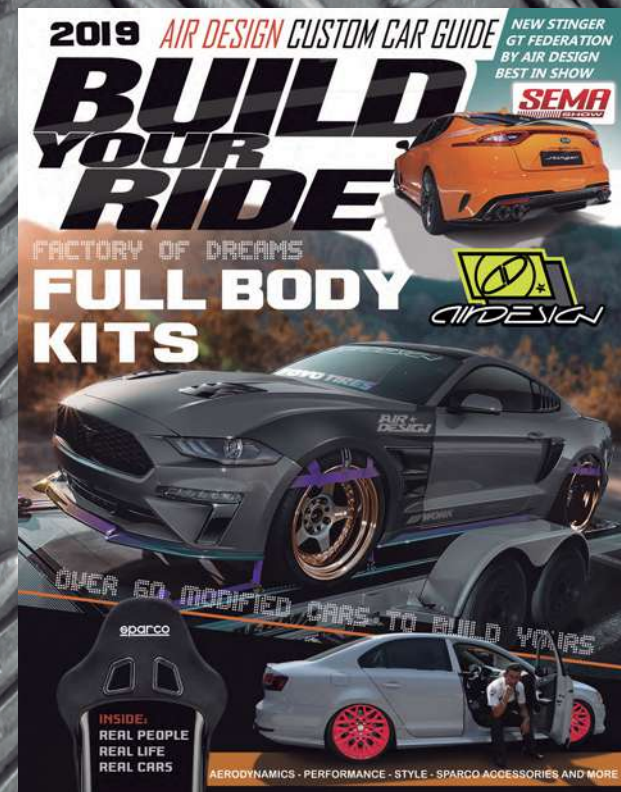

LETTER FROM THE EDITORS.

In this edition we look back to our roots in order to capture our passion for speed and customization. By flipping through these pages you will see reflected 28 years of intense experiences around the world, during which we have designed, developed and manufactured the best products and proposals in aerodynamics and sport accessories.

From the concept design to the distribution of our products, at Air Design we work driven by the dream of innovation. We hope this magazine to be a tool to share this motivation and to be used as a precious reference for your future personalization projects.



For "The Paint Shop", the most exciting thing is that there are no limits when it comes to exotic combinations, color or finish, reflections, or textures. What our finishes transmit resembles the beautiful sparkles of the sea in the sunset, as we incorporated higher-end technology with a finish that not only protects but also proclaims your personality.

The paint shop is born so that all the perceptions you have of the world of color can be put on your vehicle to take them wherever you desire. We reach the highest expression in painting and quality, in conjunction with our body kits, and with each element, we get

close to achieving the quality of a super exhibition car ready for daily use. With this, coming from the artistic medium of street art, with a great freedom of expressions in the environment of personalized cars. With painters, tinsmiths, polishers and a whole team of exceptional and capable professionals using the best technology, equipment, ovens and techniques. The detail of the work is so good that it represents what you want to express about your car with a personalized service, in addition to profession. With our Body Kits, born from artistic fusion, high-end technology, the dreams you have for your car, can all come true at The Paint Shop by Air Design. 🚗

INDICE / INDEX

VOLKSWAGEN

Jetta A7 2018-2019	10-11
Jetta A6 2011 - 2018	12-21
Jetta A5/Bora 2005 - 2010	22-23
Jetta A4/Clasico 2008 - 2014	24-27
Jetta A4 2000-2007	28-31
Gol A6 2013-2015	32
Cross Fox 2010-2017	33
Polo Europa 2013 - 2014	35
Polo India 2015 - 2019	36-37
Vento 2016 - 2019	38-39
Vento 2014 - 2015	40
Gol Sedan 2009 - 2012	41
Gol HB 2009 - 2012	42
Gol HB 2013 - 2016	43-46
Gol Sedan 2009 - 2012	47
Beetle 2012 - 2019	48-50
New Beetle 2000 - 2010	51

FIAT

500 Turbo /500C/ 500 Abarth 2012 - 2019	52-55
---	-------

RENAULT

Sandero 2016-2018	56-57
Duster 2012 - 2018	58-59
Oroch 2018 - 2019	60-61

KIA

Stinger GT 2017-2019	62-63
Forte 2019	64-65
Forte Sedán 2017 - 2018	66-67
Forte HB 2017 - 2018	68-69
Rio Street HB 2017 - 2019	70-71
Rio Street Sedan 2017 - 2019	72-73
Rio Cross HB 2017 - 2019	74-75
Rio Cross Sedan 2017 - 2019	76-77

NISSAN

Sentra 2013 - 2015	78-79
Kicks 2017 - 2019	80-81

MITSUBISHI

Lancer 2010 - 2014	82-86
Outlander 2010 - 2013	87

FORD

Mustang Convertible 2018 - 2019	88-89
Mustang Boy Racer Coupe 2018 - 2019	90-91
Mustang Ligth Coupe 2018 - 2019	92-93
Mustang Convertible 2015 - 2017	94-95
Mustang Coupe 2015 - 2017	96-102
Fusion 2013 - 2017	103
Focus HB 2011 - 2014	104-105
Focus Sedan 2011 - 2014	106
Fiesta Sedan 2014 - 2019	107
Fiesta HB 2014	108-109

SEAT

Leon FR 2015 - 2017	110-111
Ibiza 2018 - 2019	112-113
Ibiza 2013 - 2017	114-117
Ibiza 2009 - 2012	118
Toledo 2013 - 2019	119-121

CHEVROLET

Cavalier 2017 - 2019	122-123
Cruze 2016 - 2019	124-125
Cruze 2013 - 2015	126-127
Cruze 2015.5	128
Cruze 2010 - 2012	129
Sonic 2017 - 2018	130-131
Sonic Sedan 2012 - 2016	132-133
Sonic HB 2012 - 2016	134-135
Chevy 2008 - 2012/ Matíz 2005-2015	138-139
Spark NG 2017 - 2019	140-141
Spark 1lt & Classic 2013 - 2017	142-143
Spark 2lt 2013 - 2016	144
Spark 2011 - 2012	145
Beat HB 2018 - 2019	146-147
Beat NB 2018 - 2019	148-149
Aveo (Sail) 2018 - 2019	150-151
Aveo 2017.5	152-153
Aveo 2012 - 2017	154
Trax 2014 - 2016	155
Trax 2017 - 2019	156-157
Equinox 2018 - 2019	158-159

Sparco

Racing Accessories	160-161
Karting Accessories	162-163
Performance Accessories	164-165

BETTER WITH COLOR

LOW LIFE

Air Design Vehicle Personalization Center, Mexico City

Stance is a lifestyle, a cultural current that has been around for many years, starting with Hot Roads and its aerodynamic performance revolutionizing Lowriders with air suspension at birth. Nowadays, thanks to technology, this lifestyle can be incorporated into your daily car. This radically modifies the aesthetics of the car that highlights its characteristics and performance, framing the wheels that you put on, your Body Kit and the wonderful paint job, add more value and looks to your ride. 🇲🇽

VW27D09
High Profile Rear Deck Spoiler

VW27D09
High Profile Rear Deck Spoiler



VW27D04
Side Skirts Set



VW27D15
Low Profile Rear Deck Spoiler



VW27D05
Rear Spoiler with Diffuser and Decorative Exhaust Tips



VW27D04
Side Skirts Set

VW27D12
Front Air Curtains Set

THE SKATER

JETTA RACING A7 2019

The new Jetta A7 is the well deserved evolution of a classic icon to the contemporary world, Highlighting with its performance of the STREET motorsport symbols, meanwhile improving its aerodynamics and recovering the style of the 80's with it's splitters. The enormous diffuser and the abundant matte black surfaces, makes it a familiar car that does not forget its origins,

but that incorporates deserved advances that crown it in its category. In addition, this one is particularly equipped with its beautiful Rotiform gold honeycomb wheels that base their design on that specific generation, wide tires, and a new H & R suspension that stands out, even more, creating a new personality. 

 Body Kit with High Profile Deck Spoiler VW27D99

VW27D01
Front Spoiler With Splitter

 Body Kit with Low Profile Deck Spoiler - VW27D98



VW19D94 (2015- 2017)
Body Kit with Low Profile Deck Spoiler

VW19D40 (2011- 2017)
Low Profile Rear Deck Spoiler

VW19D38 (2015- 2017)
Rear Spoiler with Diffuser

VW19D10 (2011- 2017)
Side Skirts Set

VW19D37 (2015- 2017)
Front Spoiler With Splitter

LOVE FREEDOM

YOU NEVER FORGET YOUR FAVORITE CAR
JETTA A6 2015- 2017

Never forget your favorite car. Since I joined the security forces I always wanted to make me a classic car that represented me. A friend of mine had a Jetta A3 VR6 that I really fell in love with, that car stayed in my head and became an ambition of mine. Over time I got a family of my own and I decided to buy the Jetta A6. By driving my car, it gave me a sense of freedom and an inspiration to modify it".



VW19D38 (2015- 2017)
Rear Spoiler with Diffuser



It had a very discreet color, so when changing my wheels for a 20" Rotiform VLK set, I looked for the most expressive color you could find while, at the same time, I put a pneumatic suspension to make the car have a very versatile style. With these additions to my car, the Body Kit showed off perfectly, giving my car a personality and dynamism.

VW19D40 (2011- 2017)
Low Profile Rear Deck Spoiler



VW19D38 (2015- 2017)
Rear Spoiler with Diffuser



VW19D37 (2015- 2017)
Front Spoiler With Splitter

VW19D10 (2011- 2017)
Side Skirts Set

I travel with my car to the beautiful beaches of my country, enjoyed the roads, getting lost in some roads surrounded by nature. I take it on vacations and walk through streets surrounded by beautiful and elaborate graffiti, where the style of my car is integrated into the environment. It's a fulfilling feeling to see my car has become a dream come true.



VW19D37 (2015- 2017)
Front Spoiler With Splitter



Ask us For More Information
SPARCO Original Accessorie

Why did we change our original seats for Sparco?

A lot of you may wonder why we change the factory seats of our cars with Sparco seats. The vast majority of cars do not have seats that support a 4

point belt, nor provide the safety or aesthetics that these seats can give. The Sparco seats are almost always much lighter than the original. Exchanging the

stock seats for these gives you a sense of security and control in a sporty handling. They also reduce distractions when experiencing the G forces of the car

while turning and they give you a greater sense of control over your car... Did we already mentioned the aesthetics? 



VW19D05 (2011-2017)
Rear Windshield Spoiler

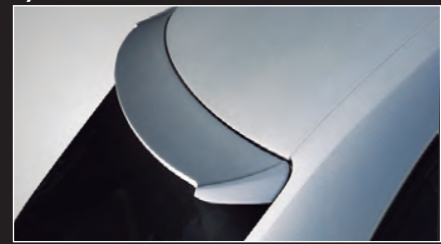

VW19D02 (2011-2017)
Fast Back Spoiler



VW19D01 (2011-2017)
Roof Spoiler



VW19D40 (2011-2017)
Light Rear Deck Spoiler



AERODYNAMIC SYSTEM

A spoiler not only gives a more sporty style to your car, it influences it's aerodynamics and it's agility at high speeds. It's important to choose one of quality and designed specifically for your car!

JETTA A6 2011-2014 SPORT EUROPA BASIC

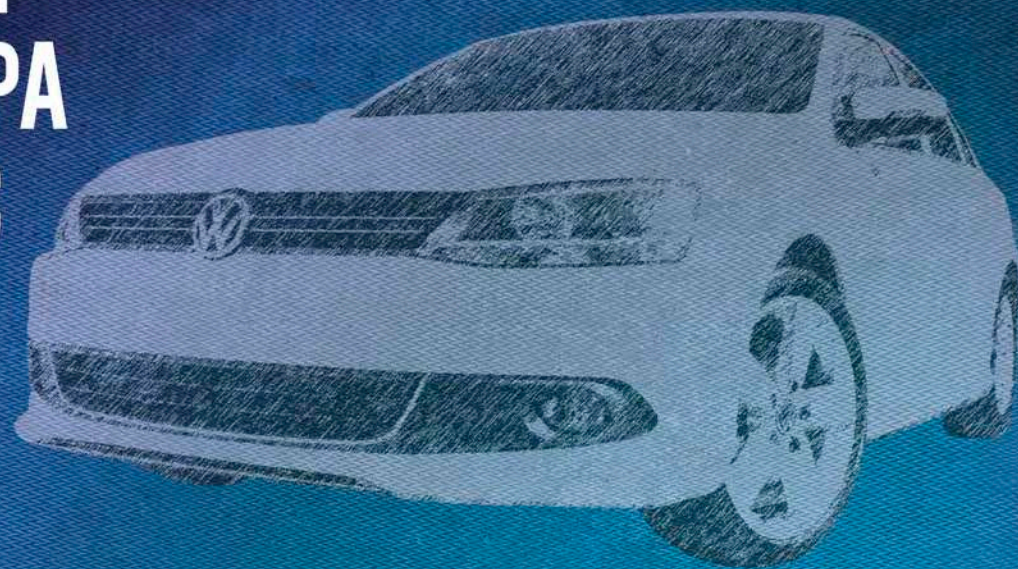

IDENTIFICA ESTA VERSION POR SUS BISELES REDONDOS

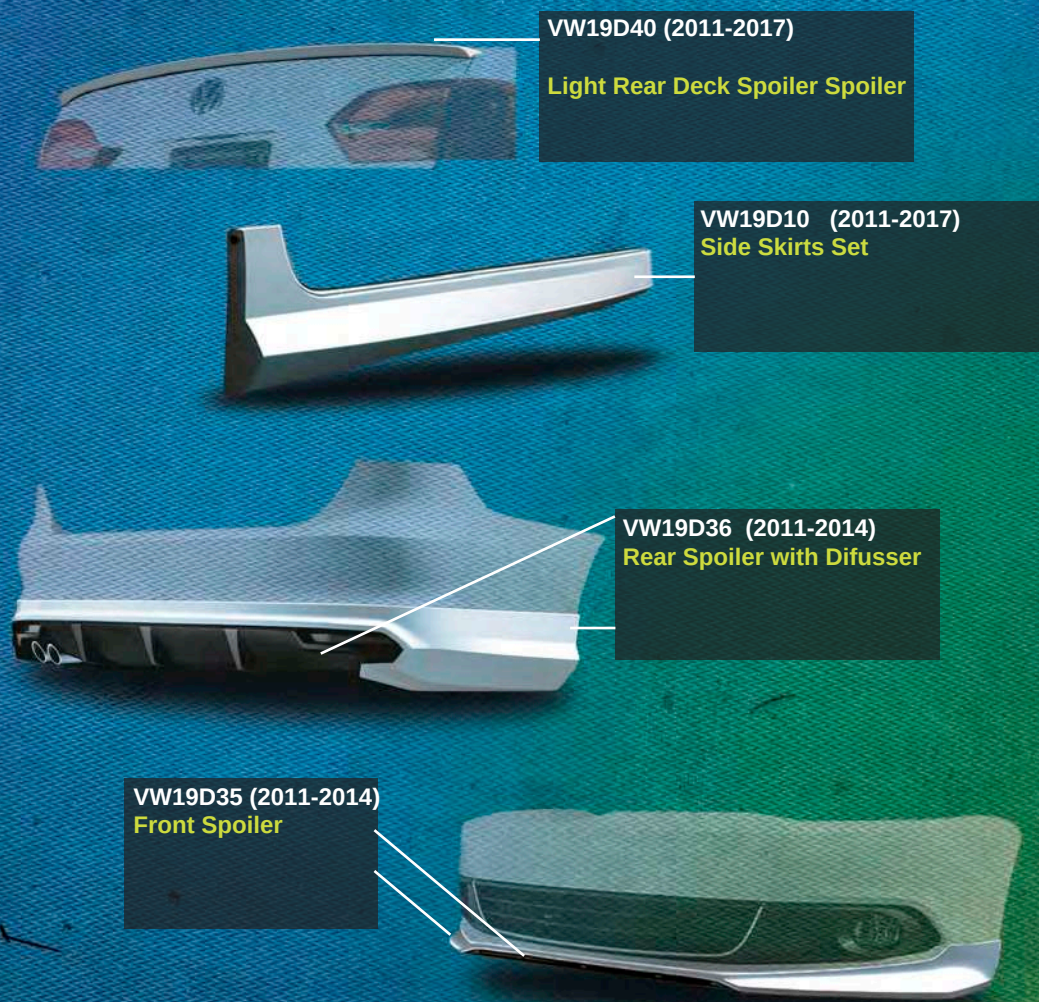

JETTA A6 GP 2015-2017



IDENTIFICA ESTA VERSION POR SUS BISELES CUADRADOS

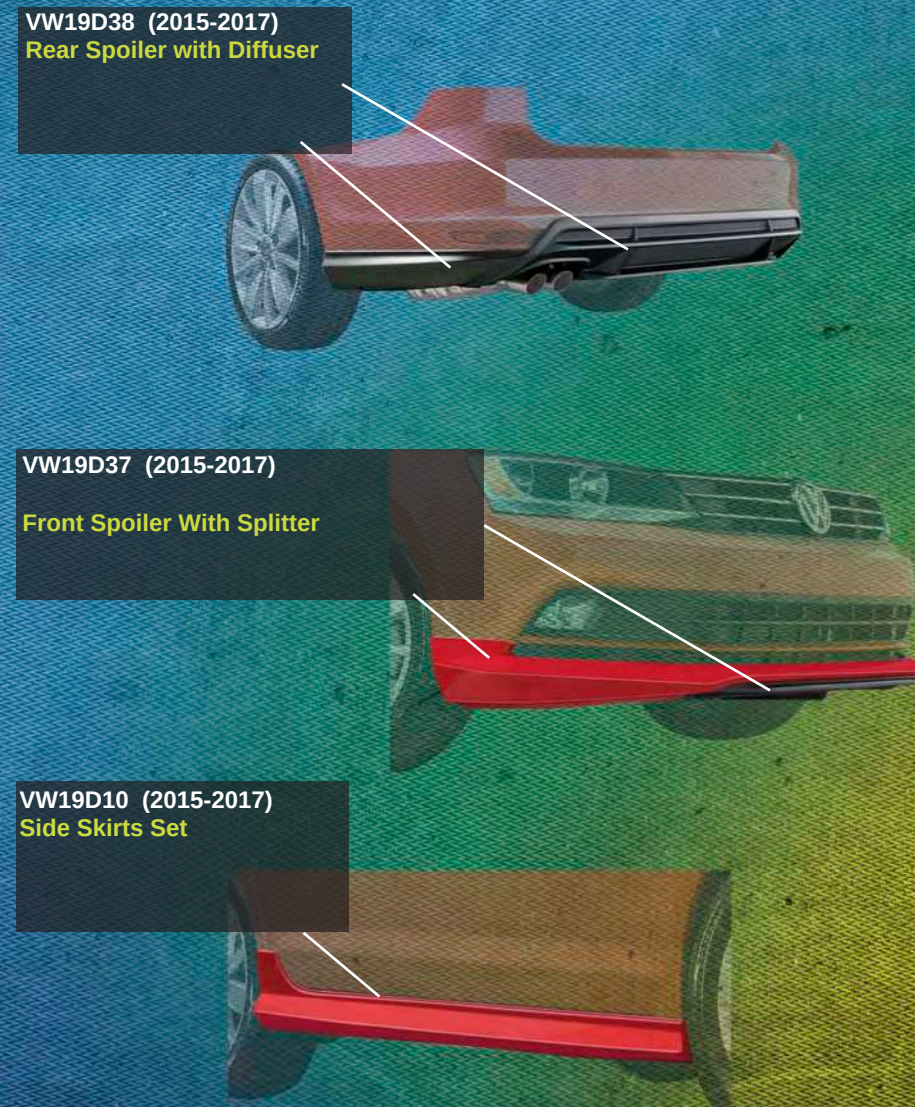

COMPLEMENTA TU ESTILO CON ALGUNO DE LOS SIGUIENTES ALERONES
COMPLETE YOUR STYLE WITH ONE OF THE FOLOWING DECK AND ROOF SPOILERS

VW19D02 (2011-2017)
Fast Back Rear Deck Spoiler

VW19D40 (2011-2017)
Light Rear Deck Spoiler

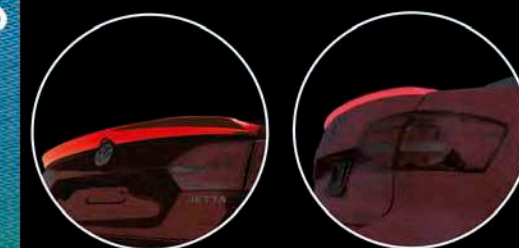

VW19D03 (2011-2017)
3 Piece Rear Deck Spoiler

VW19D01 (2011-2017)
Roof Spoiler

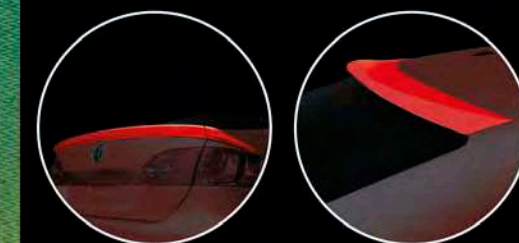

VW19D05 (2011-2017)
Rear Windshield Spoiler



VW19D06 (2011-2017)
Roof Spoiler



JETTA A6 2011-2014



VW19D15 (2011-2014)
Front Lip Spoiler



VW19D16 (2011-2014)
Rear Spoiler with Difusser



VW19D12 (2011-2014)
Front Splitters Set



VW19D09* (2011-2014)
Hood Flaps



VW19D10 (2011-2017)
Side Skirts Set



VW19D11* (2011-2017)
Lower Door Molding Set



ZZ99D07* (2011-2017)
Door Molding Set



VW19D14
PROTECTOR DE CAJUELA
(Trunk Floor Liner)



Body Kit with Front Spoiler

VW19D99



Body Kit with Front Splitters

VW19D98

* These accessories are purchased separately to the kit



VW19D40* (2011-2017)
Light Rear Deck Spoiler



VW19D03* (2011-2017)
3 Piece Rear Deck Spoiler



VW19D02* (2011-2017)
Fast Back Spoiler

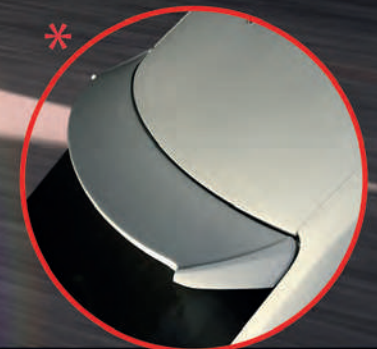

VW19D05* (2011-2017)
Rear Windshield Spoiler

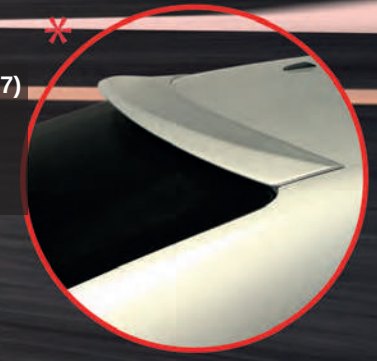

VW19D01 (2011-2017)
Roof Spoiler



VW19D13 *

(Kit of Bezels with LED Daytime Running Lights and Linear LED)



VW19D23 *

Kit de Biseles con Faros LED Luz de Día 24 hrs (Kit of Bezels with LED Daytime Running Lights)



VW19D17 *

Kit de Biseles para Faro Original con Tira de LED Lineares (KIT of Bezels with Linear LED)

2011-2014

UNFORGETTABLE



2005- 2011 JETTA A5/ BORA



VW08D03*
Roof Spoiler

VW08D02*
Light Style Rear Deck Spoiler

VW08D18
Rear Spoiler

VW08D17
Front Spoiler

VW08D13
Side Skirts Set

VW08D18
Rear Spoiler



This is the car that undoubtedly caused a revolution in Volkswagen. After having unveiled the new line of products that looked to the future, in conjunction with its partner the Golf, they were able to take some steps in the right direction. They imposed a large, elegant or sporty grill as the case may be, new technologies and refinement, Bi Xenon lights with the presence of LEDs that was quite an innovation in the market. It also comes loaded with a 2.5 VW 5-cylinder engine that did not leave anyone indifferent. Who knew that with very few modifications (such as a BBS and an Air Design Body Kit) it would be transformed into an unforgettable toy. 



Body Kit with Low Profile Rear Deck Spoiler

VW08D99

* THESE ACCESSORIES ARE PURCHASED SEPARATELY

THE FAMILY

CAR

JETTA A4 CLASICO GP
COMPETITION II
2008- 2014



VW07D03 (2008- 2014)
Roof Spoiler

VW16D05 (2008- 2014)
GLI Type Wing

VW16D44 (2008- 2014)
Rear Spoiler GLI Type

VW16D49 (2008- 2014)
GLI Type RH Side Skirt
VW16D55 (2008- 2014)
GLI Type LH Side Skirts

VW17D11 (2008- 2014)
Front Bumper Competition II with Bezels
(Without DRL'S)

"I bought my Classic Jetta as it just came out, falling in love with the new style and the old acquaintance who renewed his skin. It was the perfect car for my family and I. I had so many ideas for its aesthetics, I wanted its appearance to be really sporty, with a drag car feel to it. After the first modification the real motivation started, installing Coilovers for the suspension, wide WCI wheels with special HOOSIER tires for ra-

ces. A Sparco racing seat gave that drag car aesthetic. Once I changed the engine for a VR6, along with a new exhaust pipe and an Air Design Body Kit wich gave it more aggressive look, it felt like a drag car. Several pieces were painted in The Paint Shop, combining matte and bright blacks with orange tones with the original Silver color of the car".

Ask us for more information
SPARCO Original Accessories



VW17D11 (2008- 2014)

Front Bumper Competition II with Bezels
(Without DRL'S)



VW16D05 (2008- 2014)
GLI Type Wing

"Till until today, I'm still cruisin' in my car, enjoying it, still using it daily with my family, and every time I see it, it still brings out a smile" "Till this day, I'm still cruisin' in my car, enjoying it, still using it daily with my family, and every time I see it, it still brings out a smile"



VW16D44 (2008- 2014)
GLI Type Rear Spoiler



Body Kit GP Competition II

VW17D99



JETTA CLÁSICO A4 GP COMPETITION II 2008-2014



VW17D11

Front Bumper Competition II
with Bezels



VW17D16

Rear Spoiler with Diffuser



VW17D12

Side Skirts Set



VW07D03

Roof Spoiler



VW17D01

Low Profile Rear Deck Spoiler



VW07D02

Low Profile Rear Deck Spoiler



VW17D03

VR6 Wing



VW17D02

VR6 Wing with Stop Light

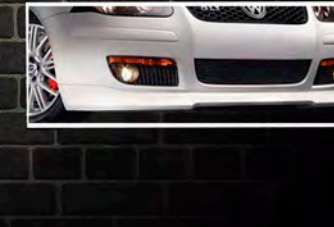

VW16D41

GLI Type Front Lip
Spoiler



KIT DE BISELES TIPO GRILL

Kit of Bezels with LED
Daytime Running Lights

VW17D13

Original (Kit of Bezels with LED
Daytime Running Lights)



VW17D17

Original (Kit of Bezels with
LED Daytime Running
Lights with Linear
LED Lights)



STYLIFE

JETTA A4 COMPETITION I 2000-2007



Body Kit with Low Profile Rear Deck Spoiler VW07D98



Ask us for more information
SPARCO Original Accessories

VW07D13
Front Bumper Competition I

Towards the late 90's and the beginning of the new 2000's, many new innovations and trends were set in place, especially in the world of personalized cars. This era capitalizes on the externalization of the personality of each driver and their cars. Skulls and LED headlights were popularized, and carbon fiber was accommodated in street cars incorporating new technologies. Iconic cars appeared thanks to some films that helped strengthen and increase the culture of personalizing your car that started back in the 40's with the Hot Rods.



VW07D13

Front Bumper Competition I

Las luces aparecieron de forma constante bajo los autos al terminar el día surgiendo esto del entorno nocturno de bares y antros con anuncios brillantes y luces de neón; y la estética de los autos se llevo a niveles insólitos con trabajos de pintura exclusivos, la modificación extrema de la carrocería, los enormes rines cromados, en fin, ¡toda una revolución de colores y emociones!

Este es el Jetta que refleja toda esa historia, un color verde Candy Electric combi-

nado con tonos negros, fibra de carbono en el cofre, rines cromados de 19 pulgadas, luces de neón blanco por fuera y por dentro, asientos Sparco luces en Leds, una fascia con grandes tomas de aire integradas al resto del body kit, nitrógeno en la cajuela y un sin numero de modificaciones performance para el auto, que sin duda alguna refleja con orgullo el estilo de vida tan increíble que, aun hoy después de tantos años, nos da alegría y emoción. 🏁

Neon lights appeared consistently under the Body from custom cars so when night time struck they would stand out. The aesthetics of the cars took to unusual levels with exclusive painting jobs, the extreme modifications of the bodywork, the enormous chromed wheels, in short, a whole revolution.

This is the Jetta that reflects all that history, with a candy electric green color combined with black tones, carbon fiber in the chest, 19-inch chrome

wheels, white neon lights on the outside and inside. It is also suited with Sparco racing seats, LED lights, a large Fascia air intake integrated to the rest of the body kit, nitrogen in the trunk and a number of performance modifications for the car. All the modifications to the performance and aesthetics undoubtedly reflects with pride the incredible lifestyle that, even today after so many years, it gives us joy and excitement. 🏁



VW07D05
GLO Wing



JETTA A4 COMPETITION I 2000 - 2007



Body Kit Competition I Front Bumper

VW07D98



Body Kit with Front Spoiler

VW07D99



VW07D13

Front Bumper Competition I



VW07D17
Front Spoiler



VW07D18
Rear Spoiler



VW07D14
Side Skirts Set



VW07D03
Roof Spoiler



VW07D06
GLX-VR6 Wing



VW07D05
GLO Wing



VW07D15

Kit of Bezels with DRL for Factory Front Bumper Ventury Style



VW07D16

Kit of Grilled Bezels with DRL for Factory Front Bumper

VW22E01
Roof Wing

VW22E07
Side Skirts Set

VW22E03
Rear Diffuser

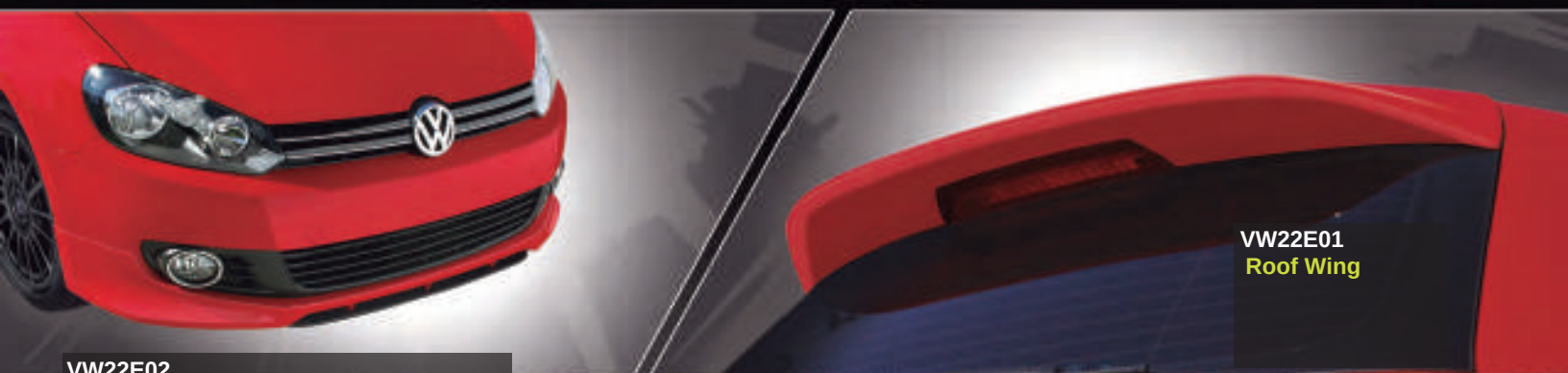

VW22E02
Front Spoiler With Splitter

VW22E01
Roof Wing

GOLF A6 2013-2015



Body Kit with Roof Spoiler

VW22E99



VW18E39
Plata Egipto
(Platinum)



VW18E50
Rojo Manzana
(Red Apple)



VW18E43
Azul Boreal
(Deep Blue)



VW18E36
Negro Mágico
(Shiny Black)



VW18E27
Gris Espectro
(Metallic Silver)



VW18E59
Naranja Atacama
(Orange Atacama)



VW18E25
Amarillo Imola
(Yellow Imola)



VW18E35
Blanco Marfil
(Ivory White)



VW18E63
(Bumper Guard)

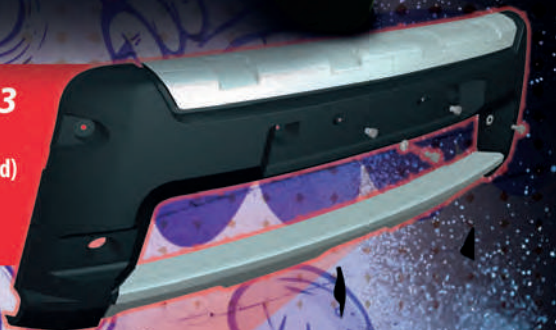

CROSS FOX



BE YOURSELF

An idea emerged, the start of a brand that could give a unique and exclusive touch to each car designed. To add the taste and ideas of each owner who wanted to take a step further in the personalization of their car. Making it possible to provide it presence with exclusive colors and designs in conjunction with high quality pieces and unparalleled configurations was something a lot of people wanted.

Air Design Original is just that, an expression of freedom and personification. A service that makes your car unique with unlimited possibilities along with deep projection in the world of automotive design. 

POLO EUROPE 2013- 2014

To speak of a Californian style we find a great exponent, the Polo TSI of Cesar developed by Air Design. The combination of the polar white color on the body with the optical and smoked skulls, 30% inked glass, WCI MT wheels -10, Body Kit and pneumatic suspension give it a beautiful exterior.



POLO EUROPE / POLO EUROPA

With the interiors covered in bone-colored leather and computer reprogrammed by API in Stange2, it ties together perfectly with a Borla exhaust system and Brembo ceramic brakes. It's truly an ecstatic vehicle. 

ORANGE TEAM

POLO INDIA 2015- 2019

VW24E07 (2015-2019)
Roof Wing



VW24E09 (2015- 2019)
Rear Spoiler with Diffuser

VW24E06 (2013- 2019)
Side Skirts Set

When getting this car, Roy knew that he wasn't always into buying top of the line. However, with money that he saved when buying the base version of the TSI Polo, it gave him the ability to focus on personalizing his car as he always dreamed of. By looking for the help from Air Design Originals to fulfill his dream, they were able to replaced the original

suspension with AG Vastago shocks, with Performance Blue springs. They also installed 19" WCI wheels with thin profile tires and a very wide body kit that perfectly combines the orange-copper tones of the car with matt blacks, and leather Sparco seats.



VW24E06 (2013- 2019)
Side Skirts Set

VW24E08 (2015- 2019)
Front Spoiler With Splitter



Body Kit with Roof Spoiler -

VW24E96

POLO INDIA / INDIAN POLO

VW24E07 (2014- 2019)
Wing



VW24E06 2013-2019
Side Skirts Set

Roy's car reminds us that the real value of an enthusiast's car does not come from the dealership, it comes from how happy it makes you. From the photos of it that you fill your

phone with, to the trips you make with it, show that your car is more than just metal on wheels. There is real value of a car like this. 🚗



VW03A11

Front Splitter Set



VW03D16

Rear Spoiler with Diffuser



VW03A10

Side Skirts Set

GOL SEDÁN

2009-2012



Body Kit (4pc) -

VW03D99

VW03A12

Bezels Set with DRL



VW03D04
Wing

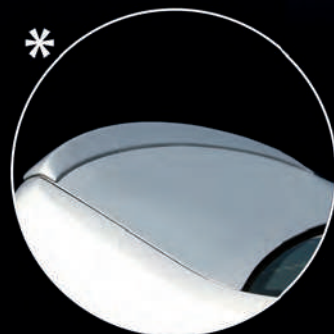

VW03D01

Low Profile Rear Deck Spoiler



* These accessories are purchased separately



VW03A11

Front Splitter Set



VW03A10

Side Skirts Set



VW03J15

Rear Spoiler with Diffuser

2009-2012

GOL HATCHBACK TRENDY STYLE



Body Kit (4pc)-

VW03E98



VW03J02
GT Roof Spoiler



VW03J05

WRCC Roof Wing



* These accessories are purchased separately
VW03A12

Bezels Set with DRL

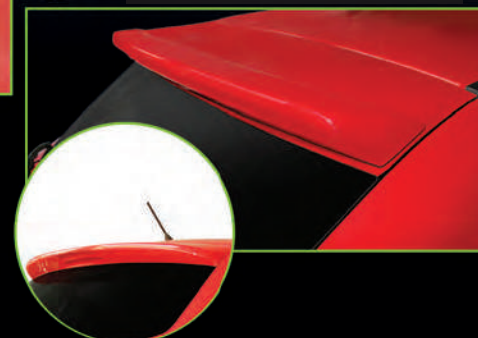

The King of the alley

Gol Hatchback 2013-2016



Body Kit With Roof Spoiler

VW25E99
2013-2016

VW25A11 (2013-2016)
Bezels with LEDS Set

VW25A02 (2013-2016)
Front Spoiler With Splitter

VW25A06 (2013-2018)
Side Skirts Set



The VW Gol is a practical, fun, reliable and simple car. It has a simple mechanic with 1.6 of 8 valves generating a little more than 100 HP to the front wheels, with ideal space to travel comfortably on roads and no struggle when parking in the city. It is not a car full of electronic sensors or loaded with technology, nor does it aspire to be a race car, but it does have one of the best power-to-weight ratios that makes it very fun to drive. It is stable and agile, all

while looking good! 16 "BBS wheels were also incorporated, along with Dunlop Sport SP 5000M wheels, Brembo perforated ceramic brakes, a suspension with H&R coilovers, stability bars signed by Ponce. They suited it up with a Magnaflow exhaust system, LEDs DRL Bezels, the complete Air Design Body Kit, and the whole set of modifications that provide you with greater grip, aerodynamics, lightness, and stability with a lot of style.



VW25A02 (2013-2016)
Front Spoiler With Splitter

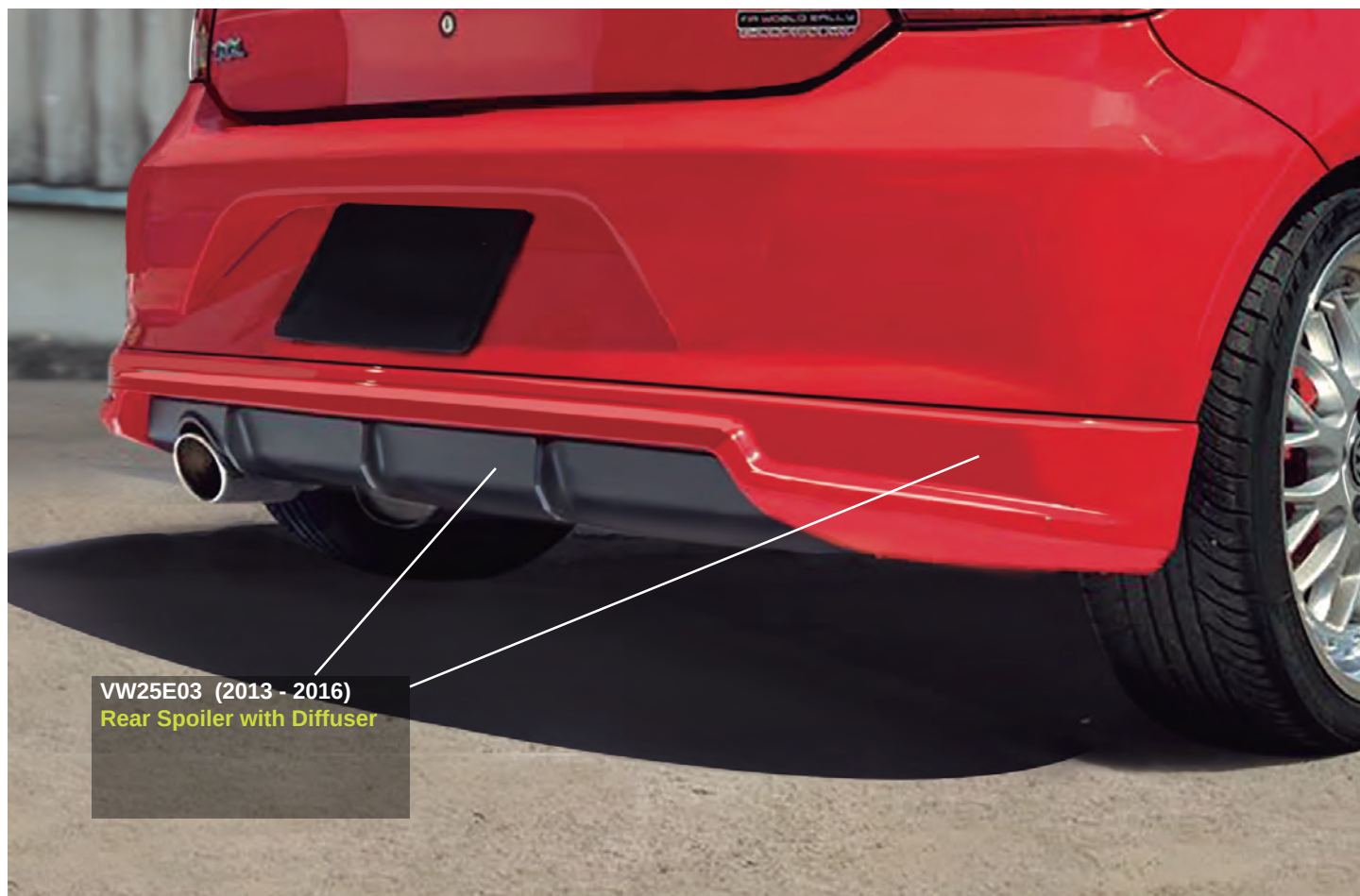

VW25E03 (2013 - 2016)
Rear Spoiler with Diffuser

This is one of the clearest examples of passion for cars. It doesn't depend on the type of car have, you do not need a supercar to feel the fun or the adrenaline. There is no need to

look for an expensive or exclusive car to have a beautiful car, after all, this VW Gol is fulfilling in the sense of passion, performance, and aesthetics. 🚗

VW25A02
Front Spoiler With Splitter

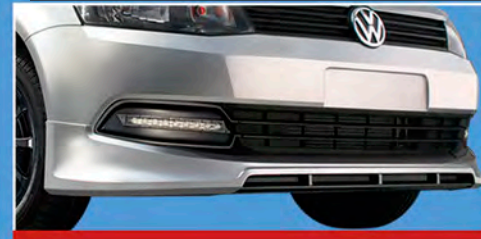

VW25E03
Rear Spoiler with Diffuser



VW25A06 (2013-2018)
Side Skirts Set

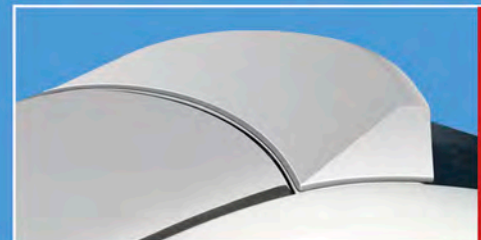
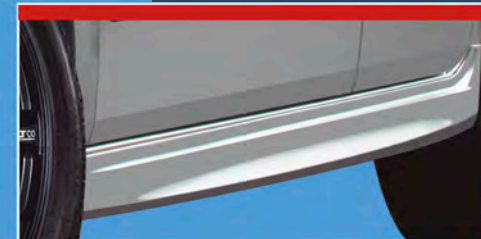

VW25E01
Roof Wing



VW25A11
Bezels Set with LED

2013-2016 GOL HATCHBACK



Body Kit with Roof Spoiler -

VW25E99



VW25A11
Bezels Set with LED



VW25D08
Rear Spoiler with Diffuser

VW25D07 (2013-2018)
Low Profile Rear Deck Spoiler



VW25A02
Front Spoiler With Splitter



VW25A06 (2013-2018)
Side Skirts Set



GOL SEDAN 2013-2016



Body Kit with Low Profile Rear Deck Spoiler

VW26D98

VENTO R 2014-2015

VW26D03 Spoiler FroWith Splitter

VW26D04 Rear Spoiler

VW26D97

VW26D99

VW26D10 Bezels Set with LED

VW26D07 Skirts Sidet

VW26D02 Low Profile Rear Deck Spoiler

VW26D01 Wing

LOW AND SLOW

VENTO 2016-2019

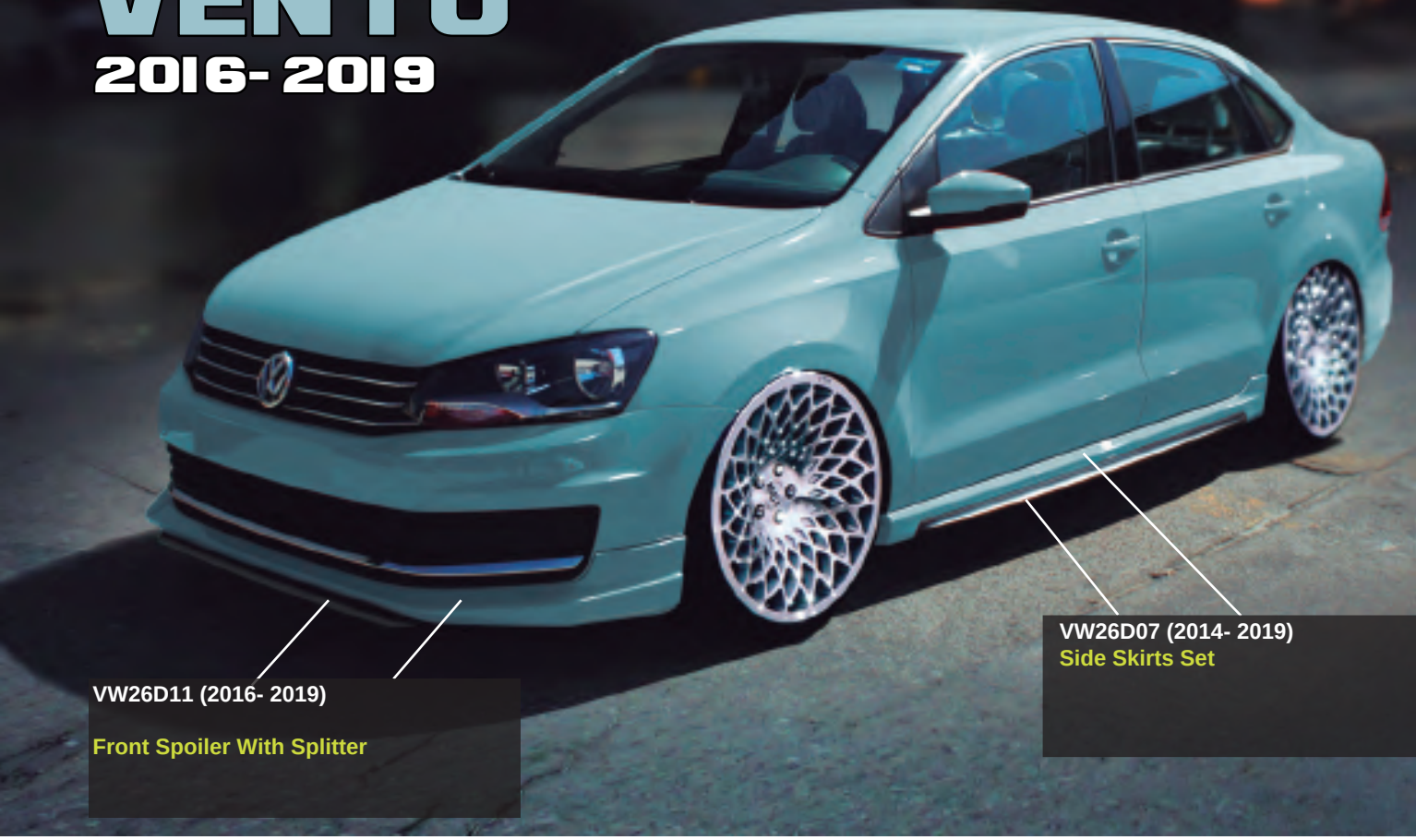

VW26D11 (2016-2019)
Front Spoiler With Splitter

VW26D07 (2014-2019)
Side Skirts Set



Body Kit With Low Profile Rear Deck Spoiler-

VW26D94



VW26D11 (2016-2019)
Front Spoiler With Splitter

There are few cars that reach this level of epicness. This VW Vento takes reference to its predecessor, the VW Sedan of the 60's' to show a retro Stance style. The paint job done by The Paint Shop in turquoise looks sublime to the color of the original model. The chromes that the car incorporates as standard were respected. This car was build with an Air Design Body Kit, 18" WCI wheels in bright brushed aluminum finish with low rim profile and an Airlift suspension, which formed a perfect set that balanced the retro image with the new age technology making the car a reference of the Stance. 🇩🇪



VW26D02 (2014-2019)
Low Profile Rear Deck Spoiler

VW26D12 (2016-2019)
Rear Spoiler with Diffuser

THE LEGACY OF THE BUGS Beetle 2012-2019



VW21E01*
Roof Spoiler

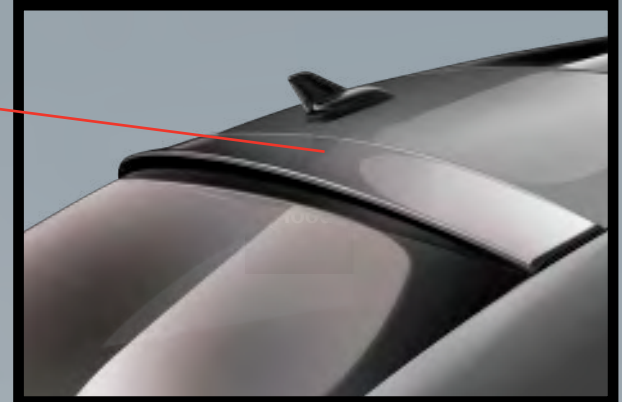

VW21E02
Wing

VW21E05
Side Skirts Set

VW21E10
Rear Diffuser for Turbo
Versions



 VW21E98
Body Kit with Regular Diffuser-

VW21E09
Rear Diffuser for Regular

 VW21E99
Body Kit with Turbo Diffuser-

When talking about the Beetle, originality is definitely included in the conversation. With a style of its own, it's an icon that set a trend and it was just what Pepe was looking for in his car. His work has him traveling all over the country, so being passionate about cars is a must. When looking for a vehicle with a great performance, agility, and of course, a lot of style, you can find it here. Aesthetics were increased when Pepe started with the modifications.

* This Accessory its purchased separately.



VW21E05
Side Skirts Set

VW21E08
Splitters Set



This VW Beetle has a sound system with a 1.5 amp which was installed featuring a Kicker woofer and an Optima gel battery. To improve performance, a new Tassel exhaust system was installed, reprogramming, Rotiform wheels of 18 "progressive and the complete Air Design Body Kit, creating a feel of power and sublime. 



VW10C02
Tail Duck Style Wing

VW10C01
Roof Spoiler

NEW BEETLE

2001-2010



EVERYBODY WANTS IT

DRIFT

STREET RACERS, KNOWN NATIVELY AS HASHIRIYA

Although street races are not legal in practically any country, there are runners with impressive cars outside the circuits in every country. Even if they are usually improvised events, they are very well organized, with the intention of reducing the dangers to the minimum. Some use the main avenues of their cities while other use stretches of roads, mountain passes and there are even places where narrow streets become tracks at nightfall.

This practice was born from the 40's, and was popularized with the birth of the Muscle Car in the 60's. Despite the fact there are different variants in each country, they will always share the excitement and passion for modified cars. With that inspiration in mind this Abarth was born.



FI02E11
Wing for Abarth Version

FI02E01
Wing for Turbo Version

 Body Kit with Wing (Fiat 500 Turbo) FI02E99

 Body Kit with Wing (Fiat 500 Abarth) FI02E98

DRIFT

FIAT 500 2012- 2019



FI02E02
Front Spoiler With Splitter

FI02E08
Wide Fender Flares Set



Air Design Proud Sponsor

CATEGORY **ABARTH500**

It is the first category in the country of Abarth 500 cars, coming from Italy, these cars are assembled in Mexico and with a Kit of competition developed by Italian engineers. It is a highly competitive category and at the same time fun for all public thanks to the qualities of these compact and modern Abarth cars.

A category supported by the best automotive technology in Mexico such as Fiat and Abarth and the not less important aerodynamics contribution by Air Design.



T500 EXPERIENCE
DRIVINGTEST



FI02E11
Wing for Abarth Version

FI02E01
Wing for Turbo Version

SPARCO Original
Accessories



FI02E08
Wide Fender Flares Set

FI02E03
Rear Diffuser

There are companies that become legendary overtime. Without a doubt, Abarth is one of them. Starting as a body shop for some Ferrari cars and then specialized in racing pieces, they were able to revolutionize the engine world with a super lightweight and powerful version for the Fiat 500 from 1957 called Abarth 695. This engine has the ability to compete in GT races with Porsches and Ferraris. It was acquired by Fiat in 1971 to be a fundamental part in its high performance cars and in 2007 Abarth resurfaced with a new

line of vitaminized Fiat products, being the most iconic the relaunch of the Abarth 500.

As the origins of Abarth, the wide Body Kit developed for the 500 and 500c in Air Design exponentially increases the dynamic characteristics of the car, give it a wider, much lower, and very aerodynamic look that is ready to see the checkered flag once again. 🏁



Body Kit with Roof Spoiler-

RE09E99

RE09E11*



RE09E03
Rear Spoiler with Diffuser

RE09E06
Side Skirts Set

RE09E01
Roof Wing



SPARCO Original
Accessories



complementó con el Body Kit de Air Design en color negro mate y detalles en aluminio. Otros accesorios incorporados en este vehículo fueron una suspensión baja con coilovers H&R, tubería directa con filtro K&N, Asientos Sparco y barras de estabilidad pintadas del mismo color verde que los rines, convirtiendo a su Sandero en uno de los Renault contemporáneos mas fantásticos del sistema solar.

MAGIC STARS

SANDERO
2016-2018

The wheels were ordered in phosphorescent green, a very colorful combination that is complemented by the Air Design Body Kit in matt black with aluminum details. Other accessories included in this vehicle are a low suspension with H&R coilovers, direct pipe with K & N filter, and Sparco seats and stability bars with the same green color. All these modifications to the Sandero undoubtedly left it as one of the most fantastic contemporary Renault in the solar system.

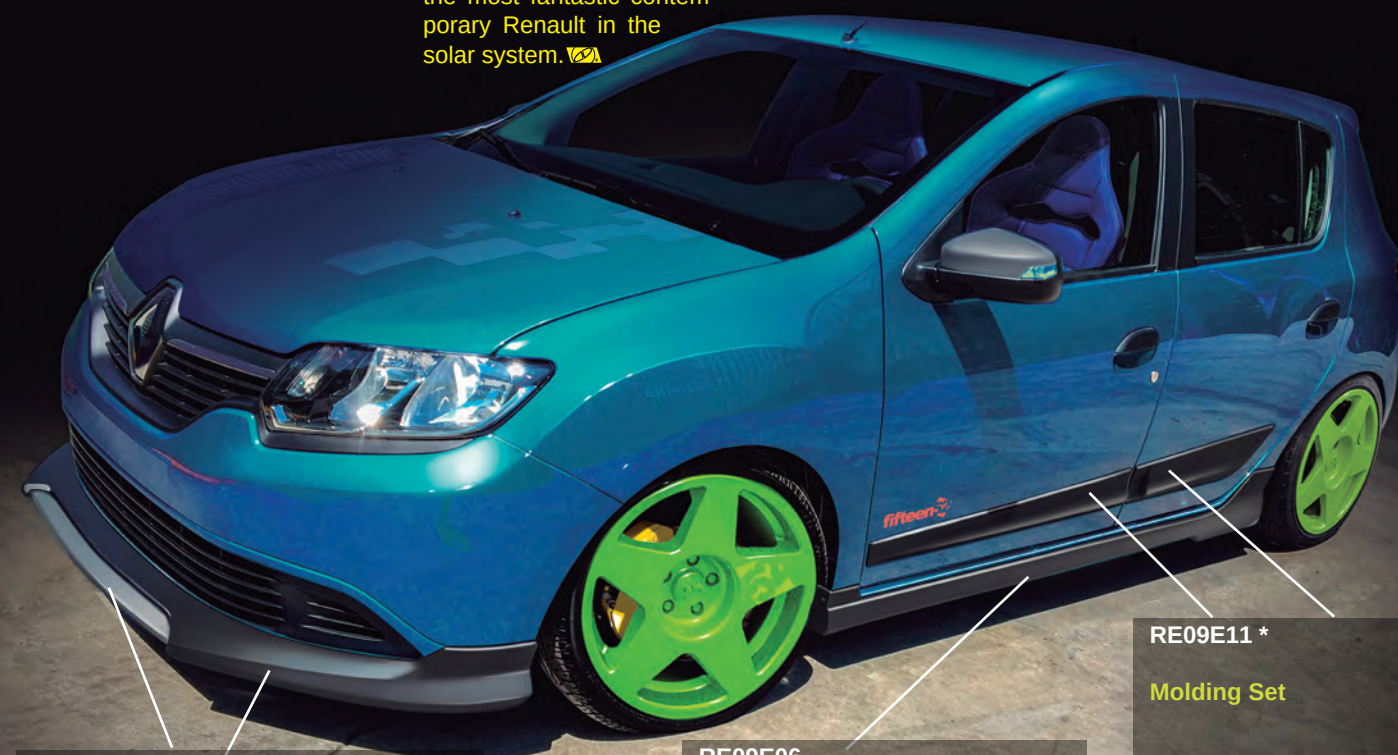

RE09E02
Front Spoiler With Splitter

RE09E06
Side Skirts Set

RE09E11*
Molding Set

*Accesorio se compra por separado.
This Accessory its purchased separately.

THE ADVENTURE OF A LIFETIME

RENAULT DUSTER 2012-2018



 GET THIS KIT FROM YOUR RENAULT LOCAL DEALERSHIP

The new limited edition of one of the subcompact SUV's of the brand in our country tried to include that fighting spirit that characterizes the cars that run in that Rally. This special edition is based on the Intens versions, but adds interesting aesthetic details, for example, the 16-inch wheels are a specific design and also incorporates exterior decals with the legend 'Dakar', rear wing, unique moldings for this model, two-tone board, steering wheel and vestments with inserts and front bumper with LED lighting.

OROCH 2019



Fender Flares Set



Door Rocket Panels Set

Front Bumper Protector with DRL LED's



GET THIS KIT FROM YOUR RENAULT LOCAL DEALERSHIP

“ If you ask me, what is the most logical format for a Duster platform? I would say that Pick-Up without thinking twice. It was no accident that their initial concept was like an SUV.

Doing it from a low-cost approach has been very convenient for the brand, but why not take advantage of its mechanical simplicity and general robustness to turn it

into a Pick-Up?

With this idea in mind, the Latin American subsidiary of Renault created the Oroch. It is, in essence, a Duster, but better. The brand did not just moisten the lid of the trunk and put a bed; but they incorporated a series of improvements that let the users to adapt their style to any situation ”

URBAN POWER

KIA STINGER 2017 - 2019

“During my stay in Tokyo, I was eager to know the lifestyle and nightlife of this technological city. In that beautiful environment I met Hiroshi, a big fan of modified cars. He devoted much of his life to find the best accessories for his cars. He showed me his Kia Stinger, a car that stole his heart from day one, because of its impressive appearance and performance. The electric blue color he chose fit the car perfectly with a set of other Brembo calipers that reminded me a lot of the Nissan GTR. This combination made his car fit in immediately with the culture of Street Racing.

Hood Vents Set
(KI03D26) Satin Black
(KI03D12) Glossy Black



Side Rocker Winglets Set
(KI03D20) Satin Black
(KI03D06) Glossy Black

Front Corner Winglets Set (Only works in GT Version)
(KI03D17) Satin Black
(KI03D03) Glossy Black



Rear Deck Spoiler
(KI03D18) Satin Black
(KI03D04) Glossy Black

Rear Spoiler with Diffuser (Only works on GT Version)
(KI03D19) Black Satin
(KI03D05) Black Glossy

Every feature I noticed from Hiroshi's Stinger and his parts very exclusive custom aerodynamic kit finished in beautiful Piano Black paint made me realize that a car with such technology. Like the rear spoiler with an integrated diffuser that provides a real downforce, has enormous potential. Everything was perfectly balanced with its Borla Carbon Fiber exhaust system and with the stunning Sky Blue Body Paint Shop, creating a perfect contrast and an explosion of color along with incredible Rotiform rims 22" inch metallic light charcoal wheels. One of the most visible aerodynamic features on this very impressive Stinger are the front and side functional winglets also printed in Piano Black finishes ending up in a very unique, clean and complete super car.”

Rear Deck Spoiler
(KI03D18) Satin Black
(KI03D04) Glossy Black



Body Kit Satin Black

KI03D96



Body Kit Glossy Black-

KI03D98

KRIPTON

KIA FORTE 2019





KI05A01 Front Spoiler

KI05A02 Air Curtains Set

KI05A06 Side Skirts Set



 Body Kit with Cutout for Exhaust Tip- **KI05D99**

 Body Kit without Cutout for Exhaust Tip- **KI05D98**

KI05D09 Rear Deck Spoiler



KI05D05 Rear Spoiler with Diffuser with Cutout for Exhaust Tip

KI05D05 Rear Spoiler with Diffuser without Cutout for Exhaust Tip

The 2019 Forte GT Federation official release at the SEMA Show 2018 was a complete success, and for this debut, Air Design decided to start the project with an entry model Forte 2019 and transform it into a real street machine! We started by lowering it approximately one and a half inches with Eibach progressive springs; we changed the tires for 19" TSW sports wheels and Azkenis FK 510 high performance Falken summer tires. We also installed a K&N cold air intake and a Borla exhaust system. But the star of this showcar was undoubtedly the Body Kit, proudly developed by

Air Design, which was inspired by the Stinger GT Federation presented at SEMA 2017, also at Kia's booth. All the parts of this Body Kit were molded by reaction injection in elastomeric polyurethane and painted in two tones. We managed to give a complex effect to the design of the front spoiler with integrated splitter, side skirts and rear deck spoiler, thanks to the dual tone painting. On the other hand, the Front Air Curtains, do function and direct the air as it passes through the front wheels; and finally, one of our favorites, the rear diffuser that gives this sedan a super aggressive style. 

AIR★ DESIGN

SUPREMACY

KIA FORTE SEDAN 2017-2018



KI02A02
Side Skirts Set with Insert

KI02A54
Front Spoiler with Splitter

 **KI02D99**
Body Kit with FX Diffuser (4 pc)
Para versiones con Salida de Escape Deportiva/ For versions with Sport Exhaust Tip

 **KI02D89**
Body Kit with EX Diffuser (4 pc)
Para versiones sin Salida de Escape Deportiva/ For versions without Sport Exhaust Tip

Life is constantly changing, your family grows and so do you, you have a better quality of life and you want your car to show that as well. For a car to have quality and class while still showing enthusiasm, the Kia Forte appeared as a great option. There is a lot of quality in a vehicle like this, for example; its good handling, top of the line equipment/ technology and excellent price for its value. However you were looking to show some more spirit so you decided to make a couple of improvements by including a 19" rims set with low profile wheels, adjustable suspension, and of course the Air Design Body Kit painted in dual tone and incorporating aluminum finish in its diffuser which highlights splendidly the large exhaust tip that this car carries from factory.

***KI02D48**
Low Profile Rear Deck Spoiler



KI02D12
Rear Spoiler with Diffuser with Cutout for Exhaust Tip (FX Versions)

KI02A02
Side Skirts Set with Insert

KI02D61
Rear Spoiler Rear Spoiler with Diffuser with Cutout for Exhaust Tip Diffuser without Cutout for Exhaust Tip (EX Versions)

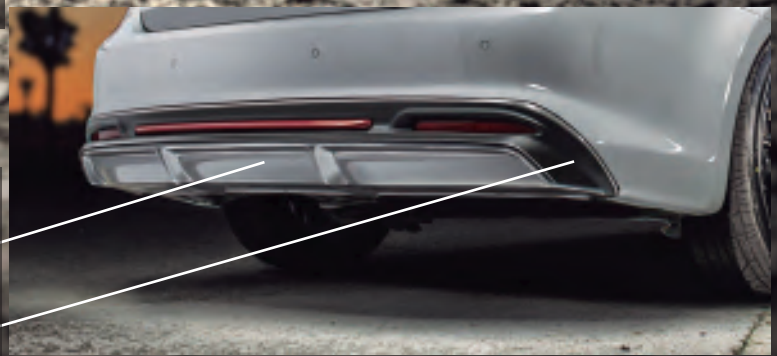

KI02A54
Front Spoiler with Splitter



KI02D48*
Low Profile Rear Deck Spoiler

* This Accessory is purchased separately

RED PARADIGM

KIA FORTE HATCHBACK
2017-2018



KI02A02
Side Skirts Set with Insert

KI02A54
Front Spoiler with Splitter

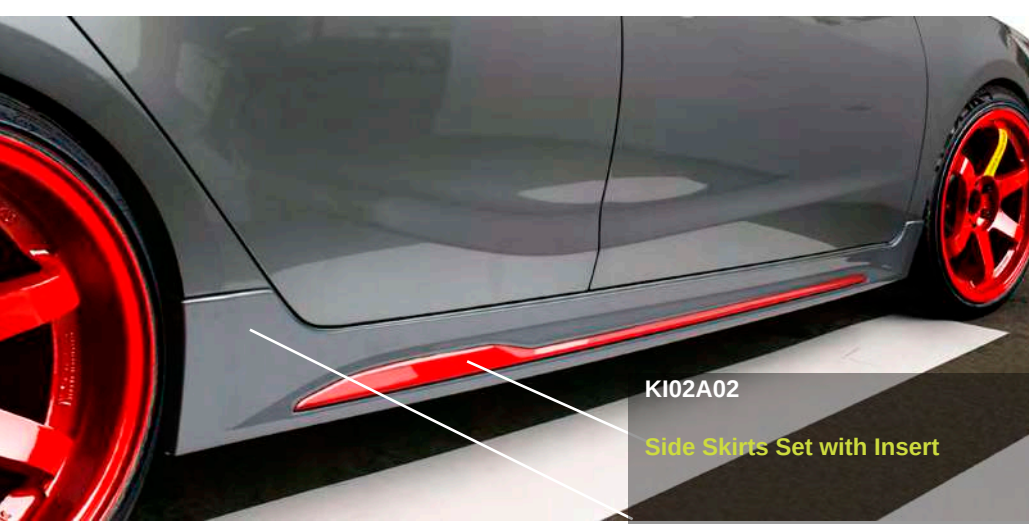

KI02A02
Side Skirts Set with Insert

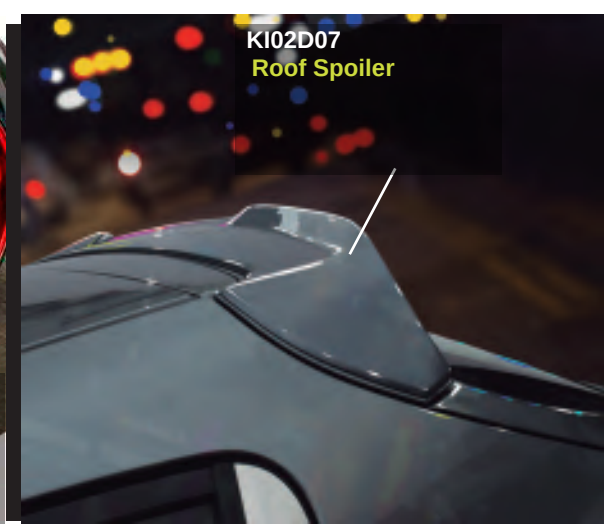

KI02D07
Roof Spoiler



Body Kit with Roof Spoiler

KI02E94

A very tough competitor arose into the medium Hatchback segment: the Kia Forte. This is an agile car, with a good weight-power ratio, wide, a very stylized aesthetics and, a sporty spirit. Dany sought to accentuate his vehicle's spirit inspired by the JDM and, just after two weeks of buying it, he installed a

RAYS wheels set in bright red, then reupholstered the entire interior to have everything in black leather and red details in Alcantara®. After that he asked Air Design to match his Body Kit to his car's body color but painting the inserts in red, giving his Forte the desired aesthetic worthy of any other JDM.



KI02D07
Roof Spoiler

KI02E14
Rear Spoiler with Diffuser and Insert for FX Versions

THE NEW CLASSICS

*** ** ** ** 7-***



KI01E39
Roof Spoiler

KI01E25
Rear Spoiler With Skid Plate

KI01E39
Roof Spoiler



Body Kit Street Style with Roof Spoiler -

KI01E99



KI01E22
Side Skirts Set



The Rio is that car that everyone recommends, either HB or Sedan. Rick was convinced once he took the car on a test drive and bought a white HB, a car with a lot of sports spirit but that did not end to reflect it in its aesthetics, so our protagonist decided to do something about it. He kept the neat white of the car and

look for Enkey wheels of 17" of the same target, modified the suspension with Coilovers to lower the height of the car, installed a Borla exhaust system and gave it a unique image with an Air Design Full Body Kit; he also added some decals in red vinyl, having an even greater result than he thought, achieving a car ready to run or for an exhibition.

KI01E11
Front Spoiler with Skid Plate

KI01D53
Air Curtains Set

KI01E22
Side Skirts Set

THE FLOWERING KNIGHT

RIO SEDAN 2017-2019



Body Kit Street Style Sedan with Roof Spoiler -

KI01D95

KI01D01
Low Profile Rear Deck Spoiler

KI01E22
Side Skirts

KI01D01
Low Profile Rear Deck Spoiler

KI01E22
Side Skirts

KI01E11
Front Spoiler with Skid Plate

KI01D53
Air Curtains

“I am a person of balance, I always try to look for the best qualities, and i bought the Rio Sedan just for that, an excellent quality-price ratio made me want it, and its lines had potential, a great starting point, but the car needed a touch of improved identity.

Fortunately there are already pieces designed specifically for this car as is the spectacular Body Kit Air Design that was integrated perfectly to the car and enhanced its aesthetics. the AG KIT suspension kit to lower the car it was already on sale too, maybe the hardest thing to find were the right wheels, which are in white. They gave my Rio the perfect identity. ”

KIA RIO HB CROSS



KI01E12
Front Bumper Protector
with DRL LED's

KI01E22
Side Skirts Set

KI01E11
Front Skid Plate



KI01E25
Rear Spoiler With Skid Plate

KI01E13
Fender Flares Set for HB

KI01E26
Door Rocket Panels Set

KI01E39
Roof Spoiler

The Cross package Air Design has developed for the Rio magnifies the virtues of this great vehicle, that is already a wide, safe, and fun vehicle, but to which it is added extra protection that allows it to go off-the-road without damaging its body. Air Design's Full Body Kit gives provides the Rio with an appearance much more rustic and adventurous, it includes Fender Flares, Side Skirts, Door Moldings, Front and Rear Spoiler with included skid plate and a Front Bumper Protector with integrated DRL lights, getting it ready for any road. 🚗



Ask for the 2" Lift Kit available for this vehicle.



Body Kit Cross Style HB -

KI01E99

KIA RIO SEDAN CROSS 2017-2019



KI01E12
Front Bumper Protector with DRL LED's

KI01E22
Side Skirts Set

KI01E11
Front Skid Plate

 Body Kit Cross Style Sedan **KI01D97**



The silver Rear Diffuser is painted from factory

KI01D49
Rear Extensions Set

KI01E26
Door Rocker Panels Set

KI01D46
Fender Flares Set for Sedan

KI01D01
Low Profile Rear Deck Spoiler



Ask for the 2" Lift Kit available for this vehicle.

This Sedan equipped with Air Design Cross Style Body Kit is definitely an eye-catching. It is distinguished by its more robust aesthetics, where the plastic protections on the fenders and lower parts of the body stand out, as well as the incorporation of the same wheels and tires of its simile Hatchback.

The final result is extremely interesting, since, in addition to having a generous trunk capacity, it has the strength and agility, ideal to get ahead of the most difficult roads with the dreadful potholes, bumps and other imperfections are constants. Is this car perfect for the city and the countryfield? That is just what we want to show. 

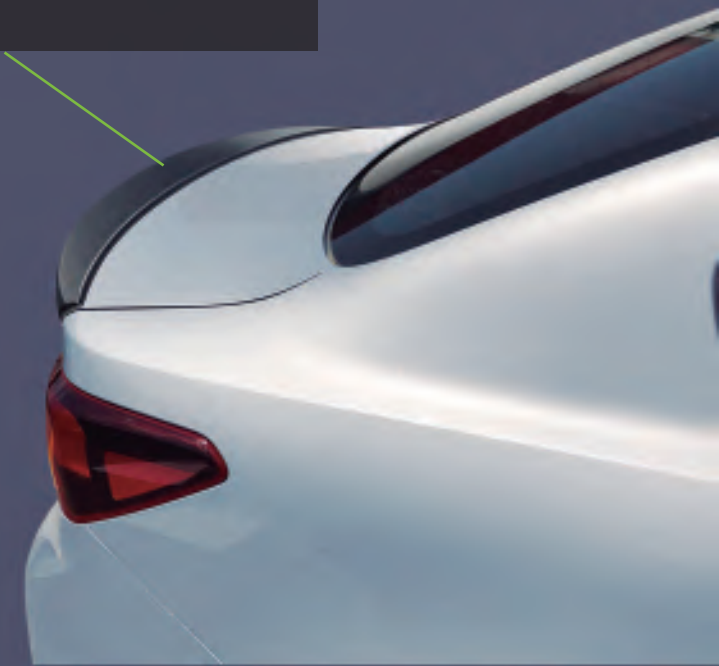

STORY COMPLETED



NI08D06 2013-2019
Rear Deck Spoiler



NI08D05 (2013-2019)
Side Skirts Set

NI08D02 (2013-2015)
Rear Spoiler



NI08D01 (2013-2015)
Front Spoiler

Body Kit with Low Rear Deck Spoiler

NI08D98

Jose Antonio has a true passion for JDM, he found this crashed Sentra and decided to not only restore it, but to transform it into a prideful work of art. He repaired the damages it had with extreme dedication

and caution. After the damages were gone he swapped the engine for an SR20T and put 17" RAYS wheels with Toyo Proxes tires. The final step was to take it to the Paint Shop by Air Design to paint the car in Gray

Platinum, the wheels in gold and both, the grille and the Air Design Body Kit, in a graphite color giving a new life to his Sentra, a life worthy of a legend. 🏆



NI08D01 (2013-2015)
Front Spoiler

NI08D05 (2013-2019)
Side Skirts Set

NI08D02 (2013-2015)
Rear Spoiler

NI08D06 (2013-2019)
Rear Deck Spoiler



GET THIS KIT FROM YOUR NISSAN LOCAL DEALERSHIP



NISSAN KICKS 2017 - 2019
HERE IS
THE REAL
KICKER



This SUV has almost everything! it has a very urban origin but lacks that feeling of roughness and strength. Just for that reason, at Air Design, we decided to give it a better image with a suitable Body Kit. The kit includes Front, Rear and Side Skid Plates and a Roof Spoiler that combine Satin Black with aluminum finish to protect your Kicks' sheet metal while making it look adventurous and ready for action. 🚗

GENKAKU

THE MOST POPULAR CARS LANCER 2010-2014

This is the car that exposes JDM, the Japan Domestic Market, to the maximum. But that leaves the question, apart from what the acronym stand for, what really is the JDM? In motoring culture, JDM refers to a modification of the style of automobiles. The aesthetic style of the components is very similar to those left by the production lines, that is, parts that maintain the sober sense of the manufacturer and are incorporated by trying to follow or maintain the original line of the car.

In the JDM everything applies when it comes to what can be improved with respect to the mechanical performance of the car, from the change of normal spark plugs for high performance to the change of engines and modifications of them. A more appropriate explanation would be that the JDM style improves the vehicle with a series of pieces from purely Japanese brands. These pieces do that, not by eccentricity, but rather by simplicity when seeking to maintain the original lines of the vehicle.

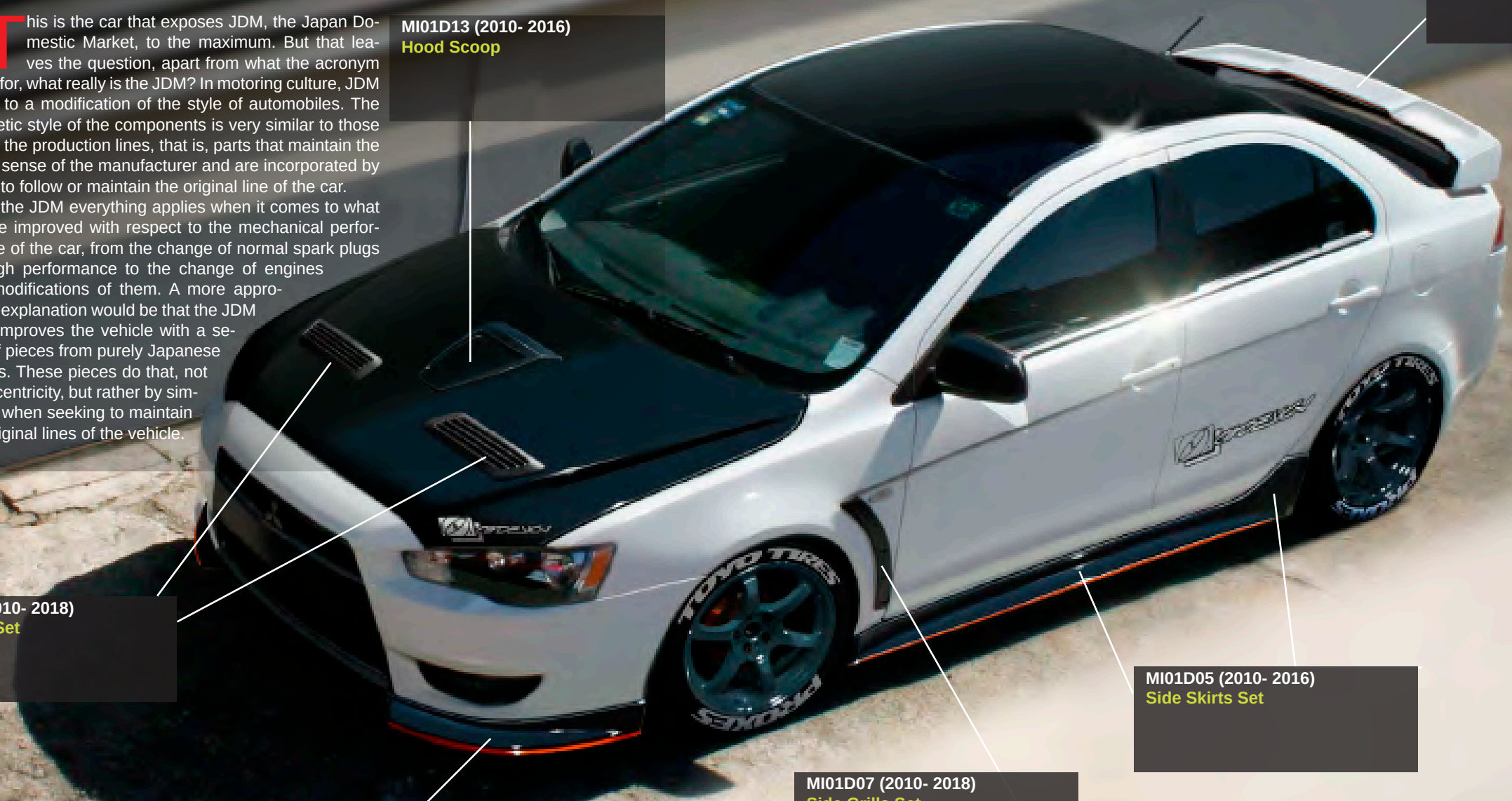

MI01D13 (2010-2016)
Hood Scoop

MI01D02 (2010-2018)
EVO Style Wing

MI01D06 (2010-2018)
Hood Vent Set

MI01D05 (2010-2016)
Side Skirts Set

MI01D07 (2010-2018)
Side Grills Set

MI01D08 (2010-2016)
Splitters Set

 Body Kit with EVO Style Wing
MI01D98

The Mitsubishi Lancer was manufactured uninterruptedly from 1973 to 2017 and from its first generation came a winner of multiple rally races.



MI01D07
Side Grills Set

MI01D08
Splitters Set

That's why Tony's Lancer is so special, all his aesthetics do not do more than magnify the original lines of the car and improve the performance. Since all the pieces that he installed were specifically designed for his car, both the trunk and the hood were replaced with carbon fiber parts lightening the whole weight of the vehicle. He installed 17" RAYS rims with Toyo Proxes tires, a Garret turbo of variable geometry, and forged the piston rods. He also changed the factory seats for Sparco's with 4-point belts and a steering wheel of the same brand. Adjustable R&R Coilovers suspensions and Brembo ceramic brakes were added, and the car was completed with the Full Body Kit from Air Design, created specifically for this model, making sure it holds the Japanese spirit of the king of Rallies. 🏆



SPARCO Original Accessories



DO IT
RIGHT



MI01D05
Side Skirts Set



MI01D02
EVO Style Wing



OUTLANDER 2010-2013 GT



MI02E03
Hood Vents Set



MI02E01
Front Bumper
Guard



MI02E07
Rear Skid Plate



MI02E04
Front Splitters Set



Body Kit

MI02E99

BRING ON THE Classic Style

2018-2019 Ford Mustang Convertible

At the beginning of the 1960s, Lee Lacocca commissioned Gene Bordinat to design a new concept of a 'compact' and sporty vehicle. The reason? The success of European cars and the fall of Ford Thunderbird sales. The designer and his team got down to work and in 1962 they had prepared the first concept car. A year later, Joe Oros would be in charge of the second prototype. It was 'small' and lightweight, had four independent stools and the gear lever was born from the ground. His image transmitted strength and sportsmanship. In April 1964, Ford presented the version that was going to be commercialized at the New York Auto Show and, to the amazement of the whole team, the first day on the market twenty thousand units were sold. 🚗

FO22A17
High Profile Rear Deck Spoiler for Convertible Versions

FO22A09
Fender Vents Set

FO22A06
Side Skirts Set

FO22A17
High Profile Rear Deck Spoiler for Convertible versions

FO24A33
Rear Valance Diffuser

FO22A01
Hood Vents Set



FO22A12
Side Scoop Set

FO24A34
Front Bumper with Splitter



THE FUGITIVE

MUSTANG COUPE BOY RACER 2018-2019



 Boy Racer Body Kit with Window Louvers **FO24A99**

 Boy Racer Body Kit with Window Scoops **FO24A98**

FO22A15
Widow Louvers Set

FO22A12
Side Scoop Set

FO22A09
Fender Vents Set

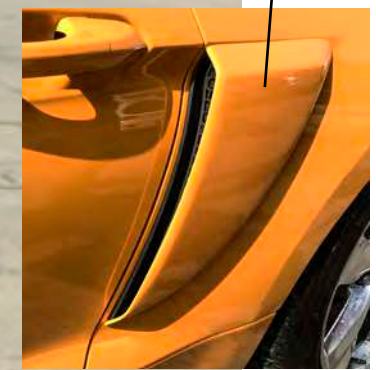

FO22A34
Wing

When I started to modify my new Mustang, I bought parts that would improve its performance, but back then I had not found any accessory that were able to express the same strength on its outside without losing functionality. I wanted a car that could do amaze more than one and, with that in mind, I started searching the web and found on the Air Design website something that combined all the essence and perfect aerod-

ynamics I was looking for. From the two versions that Air Design had available for the latest generation of the Mustang, I bought the Boy Racer Body Kit which fit perfectly to my car and also provided the good aerodynamic and the exceptional style I was expecting for. 🏆



FO24A13
Widow Louvers Set

FO22A15
Quarter Window Scoops Set



FO22A01
Hood Vents Set



FO22A06
Side Skirts Set

FO22A09
Fender Vents Set

FO24A34
Front Bumper with Splitter

2017 **SEMA** SHOW **VEHICLE** AWARD WINNING

Master Piece MUSTANG

LIGHT COUPE 2018 - 2019

FO24A06
Hood Vents Set

FO24A28
Air Curtains Set

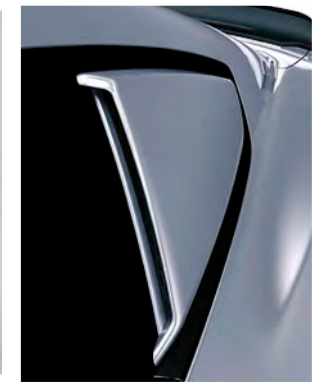

FO24A33
Rear Diffuser

FO22A15
Quarter Window Scoops Set

FO24A13
Louvers Set

Choose the one you like the most!



FO24A32
Low Profile Rear

FO24A31
Front Splitter for Factory Bumper

FO22A12
Side Scoop Set

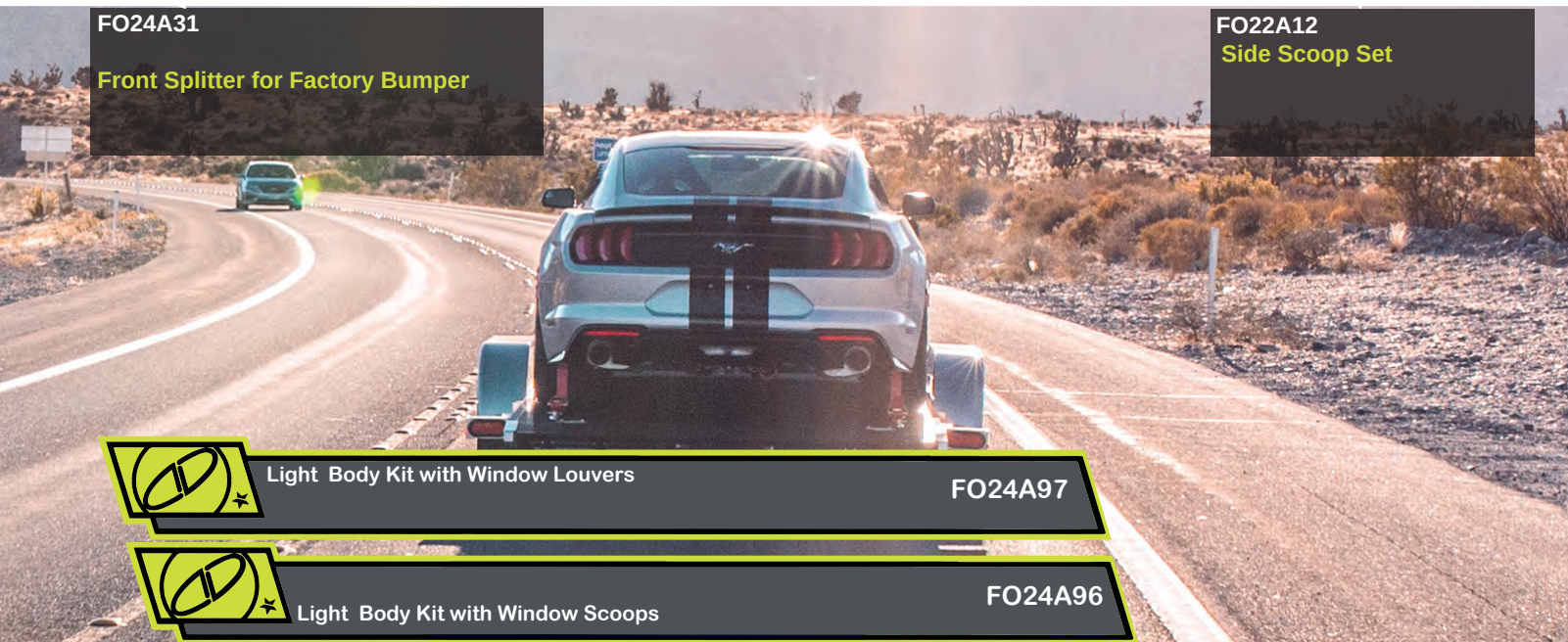

Light Body Kit with Window Louvers

FO24A97

Light Body Kit with Window Scoops



FO24A96

At Air Design we value aesthetics a lot, but we know that it's not everything. A Master Piece is only achieved by using the appropriate elements without giving too little or too much. When we were summoned to present a car at the 2017 SEMA Show Ford's booth

we knew we needed to equip our stock Mustang GT with the best components worthy of an exhibition car. With a powerful Coyote V8 engine we increased the car's performance, we exchanged the stock wheels for Rotiform 19" rims and Falken improved performance tires.

The next step was to lower its suspension and, of course, to add the Light Body Kit for Mustang we developed, which gave better aerodynamics and a much more elegant and sporty look. At The Paint Shop we gave the Mustang a Silver Metallic color paint job with Glossy

Black stripes going down the middle. It goes without saying that the car was a success and was worthy of Ford's Special Recognition for Outstanding Achievement in Design Award that year. 🏆

-  Body Kit with Front Splitter **FO22A99**
-  Body Kit without Front Splitter **FO22A90**



FO22A12
Side Scoop Set

They say there is no better feeling of freedom than you can experience in a convertible driving on the road, and I always wanted to make that dream come true a trip from coast to coast on beautiful roads with the tonneau-cover, open and while there are great convertibles like the Mazda MX5 or the BMW Z4, I looked for a much more classic style.



A DIFFERENT PLAN

FORD MUSTANG CONVERTIBLE 2015- 2017



FO22A01
Hood Scoop

The first Ford Mustang manufactured in the world was a white convertible with V8 engine and automatic gear-box with only 3 changes, doesn't seem like much. Right?

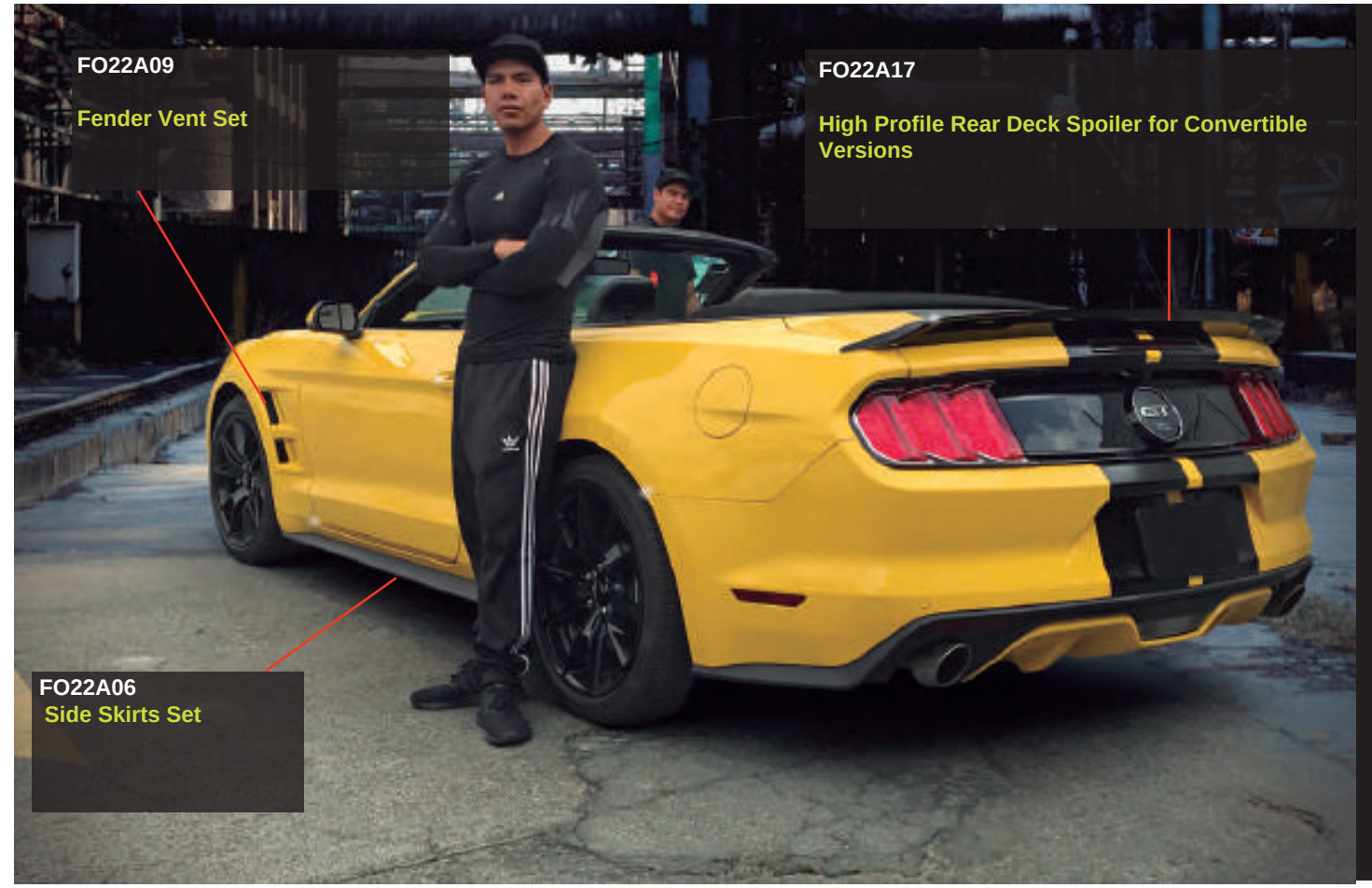

FO22A09
Fender Vent Set

FO22A17
High Profile Rear Deck Spoiler for Convertible Versions

FO22A06
Side Skirts Set

This Mustang definitely met all expectations! To make my trip I needed the car to be spectacular in every way, I put my hands to work and lowered the suspension, installed a Full Performance Air Design Body Kit and a much more noisy exhaust system, and after all that I can only say that they had a reason, making that trip with my Mustang was the best experience of my life. 🏆



Body Kit with Splitter (13 pc)

FO22A98



Body Kit without Splitter (12 pc)

FO22A89



THE LEGEND

2015-2017 MUSTANG

This is one of those cars that needs no introduction, the Ford Mustang was born with the aim of conquering the North American market back in the 60's thanks to its design, power and size. It was able to achieve much more than just a good looking car, it became a cultural and aspirational reference that, generation after generation has accentuated and reinvented its sportsmanship. However, for Jim his stock 2015 car had much more potential. He changed the tires to Goodyear Eagle GT2,

installed bigger Brembo ceramic brakes with hyperventilated perforated discs, an adjustable Eibach Performance suspension, roll bars, K&N filter; it was also given an Akrapovič exhaust system and had the computer reprogrammed. By last, he installed Air Design Body Kit that combined perfectly its Satin Black finish with the blue colors of the car's body. Jim's car became one of the most amazing racing Mustangs in the whole country. 

THE KI OF

2015- 2017 MUSTANG COUPÉ

NG DDM POWER

FO22A01
Hood Scoop



FO22A03
Front Splitter (Only can be installed under with Air Design Bumper)

FO22A02
Front Bumper Replacement

This is the Mustang that every racer dreams of having, a powerful, iconic, equipped, agile, powerful car, a dream car, a huge super-charged Coyote 5.0 engine, rear-wheel drive, racing tires, special new tubing, calibrated track suspension, and a complex and functional Performance Body Kit that aims to improve the aerodynamics and ventilation of the entire car.



FO22A06
Side Skirt Set

FO22A18
Rear Spoiler with Diffuser (Only fits on Ecoboost Versions)



FO22A23*
Side Rocket Winglet Set

FO22A12
Side Scoop Set



* This Accessory its purchased separately.



FO22A09
Fender Vents Set

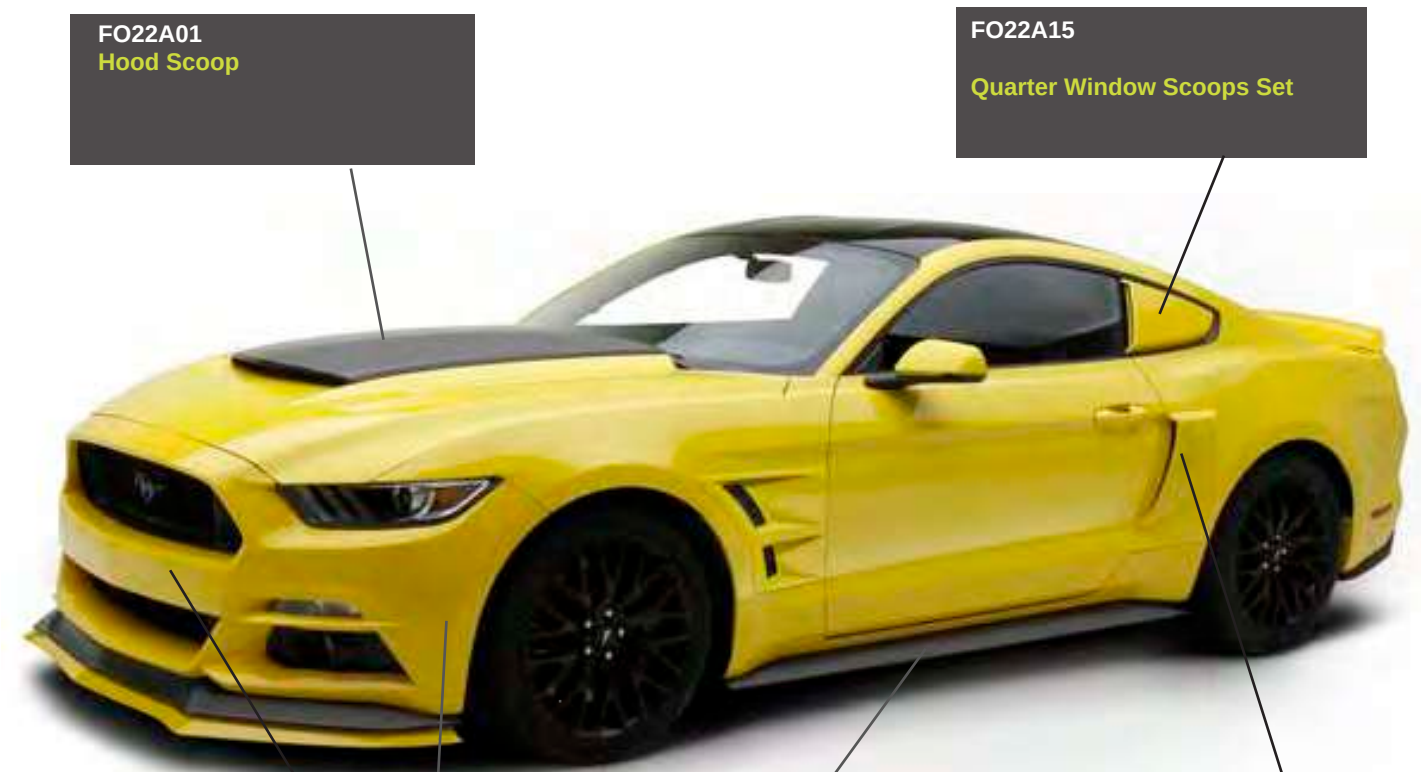

FO22A01
Hood Scoop

FO22A15
Quarter Window Scoops Set

FO22A02
Front Bumper Replacement

FO22A06
Side Skirts Set

FO22A12
Side Scoop Set

With the front we started with a Front Bumper Replacement and a Splitter that maintains the original grill intakes but lowers the height of the car, we also have a Hood Scoop and at the sides we have several elements, Fender Vents, Side Scoops in the rear windows and side sills, and to give the last detail we have behind a High Profile Rear Deck Spoiler, creating a fantastic set of aerodynamics and aesthetics. 🚗



FO22A15
Window Scoop Set

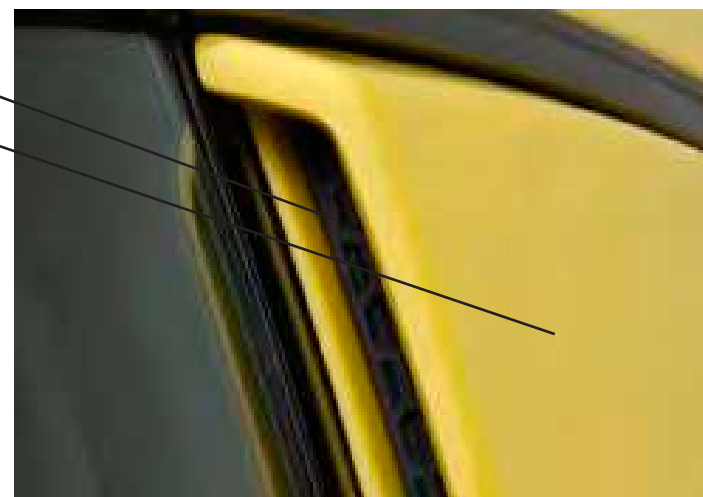

Black Honeycomb Grills included



FO22A03
Front Splitter (Only can be installed under with Air Design Bumper)

FO22A02
Front Bumper Replacement

The Ford Mustang is not just an American success, it is also for the automotive industry in general. Together with the Porsche 911, it is one of the most renowned

sports cars in the history of the automobile industry (they havent sold more than 10 million units in vain).

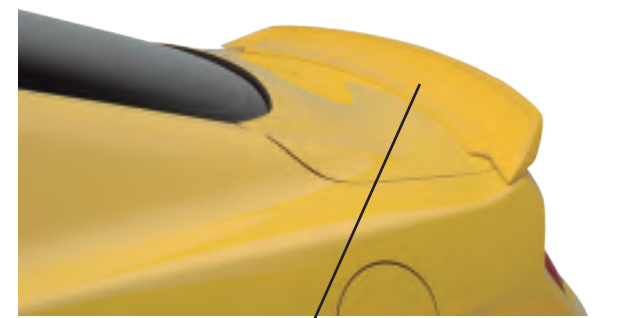

FO22A16
High Profile Rear Deck Spoiler for Coupé Versions



FO22A18
Rear Spoiler with Diffuser (Only fits on Ecoboost Versions)

FO06D08
Spoiler Front



FO06D12*
Rear Spoiler with Diffuser

LA ESPERA TERMINÓ

FUSION 2013-2016



*El Spoiler Trasero con Difusor solo puede instalarse en versiones FO06D08T
Rear Spoiler with Diffuser only can be inst. for FO06D08T Versions

Kit Deportivo Kit spoiler -

FO06D11
Skirts SeSid

FO06D07

FO06D97

FO06D96

FOCUS

HATCHBACK 2011-14

The Focus is usually classified as a more serious car, a car that does everything right but doesn't necessarily stand out. Vic didn't think the same, knowing that it was a very underestimated car and decided to get a Focus and make it the most amazing car in the neighborhood. Starting with a completely stock 2012 Focus SE and got right to work. The first step was changing the stock filters for high performance conical with a complete pipe specially prepared for it. It got some new superlight rims with high performance wheels and grooved brakes, he also installed a new audio system. As for painting, he decided to keep the original color but went to The Paint Shop to paint the Body Kit in a very genuine way, leaving the upper part black and the other half phosphorescent green creating a unique combination. Vic's car now have the style that always deserved.



* 3D691932
Roof Spoiler



FO15K07
Side Skirts Set

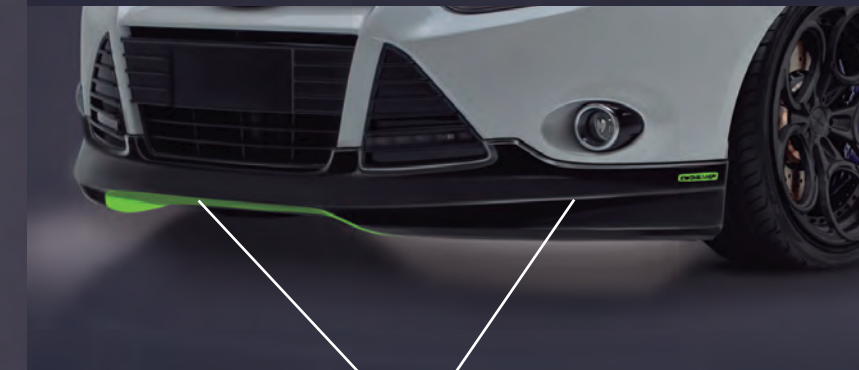

FO15D04
Front Spoiler with Splitter



FO15E09
Rear Spoiler with Diffuser



 Body Kit without Roof Spoiler (4 pc)- FO15E96

*Accesorio se compra por separado
This Accessory is purchased separately

FOCUS SEDAN 2011-14



FO15K07
Side Skirts Set



Body Kit with Low Profile Rear Deck Spoiler

FO15D98



Body Kit with Wing

FO15D99



FO15D04
Front Spoiler

FO15D03
Rear Spoiler with Diffuser

FO15D01
Wing

FO15D02
Low Profile Rear Deck Spoiler

FIESTA 2014-2018 SEDÁN



FO19K03*
Front Lip Splitter



*This Part only can be installed under Air Design's Front Spoiler



3D691623
RH Side Skirt

FO19K02
Front Spoiler



FO13D02
Low Profile Rear Deck Spoiler



FO13D01
Wing



3D691624
LH Side Skirt



THE ART OF EVOLUTION

FORD FIESTA HB 2014-2016



Body Kit with Roof Spoiler

FO19E99



FO19K03*
Front Lip Splitter (Only Fits Under Air Design Spoiler)

FO19K02
Front Spoiler

* This Accessory is purchased separately



FO19E01
Roof Spoiler

3D691624
LH Side Skirt

3D691623
RH Side Skirt

3D691622
Rear Spoiler

The Ford Fiesta is a very expressive and dynamic car, original, adventurous, and a youthful spirit. That's why to celebrate the anniversary of The Paint Shop we decided that the Fiesta would be the ideal build for our celebration. Just like its personality, we gave it a chameleon paint job that gives an incredible Under-

ground style to the car. The Air Design Body Kit with a great combination of 17" wheels with the same chameleon color and low profile tires that complement the car with a low suspension, giving us a true trophy car that grabs the attention on the streets. 🏆

THE KING OF ALLEY

SEAT LEON 2015-2017

Chris has a really special Leon FR, although there are many modified FR, his is careful to show his style Stance while at the same time providing maximum performance. He reprogrammed the computer, modified the turbo, put some lighter wheels with high-performance Falken wheels, Magnaflow pipe and an H&R adjustable suspension system. To top it off and give it its finishing touches Chris ordered an Air Design Body Kit performance in a matte color with bright purple paint brushed gold wheels, giving a completely unique look and unstoppable strength.



SE09B02
Roof Spoiler



SE09B05
Door Moldings Set



SE09B01
Front Spoiler with Splitter



Body Kit with Roof Spoiler-

SE09B99

AIR ★ DESIGN

THE FIGHTER

START THE CHALLENGE

SEAT IBIZA 2018-2019



2018+ IBIZA EXPECTED RELEASE- MARCH 2019

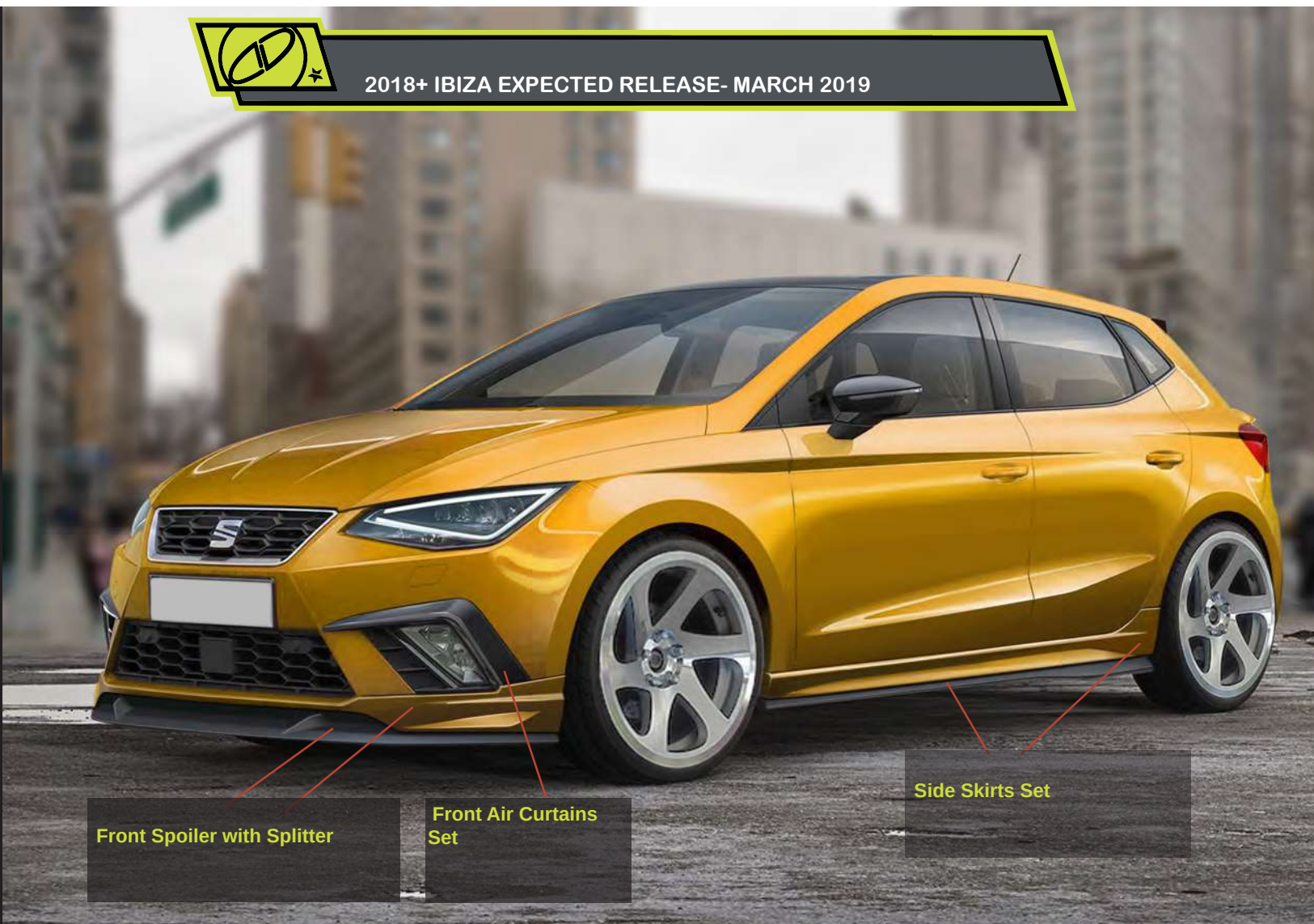

Front Spoiler with Splitter

Front Air Curtains Set

Side Skirts Set



Roof Spoiler

Rear Spoiler with Diffuser

Side Skirts Set



When someone looks for a good compact car, one of the best options is an Ibiza. This generation is no different. The 2018 Ibiza became a more advanced, refined, agile, and fun car. It was still able to maintain a moderate size with great optimized space. On the outside, its more radical and sporty look

integrates the design lines of its elder brother the Leon, which will stand out beautifully with the Body Kit that Air Design is preparing. Estimated release month is March 2019.

THE FINE TOUCH

SEAT IBIZA 2013-2017



SE06B30
3 Doors Side Skirts Set

Un Ibiza como primer auto es cómodo, seguro, divertido y

SE07G01
Front Spoiler



Body Kit with Roof Spoil SE07B99
APLICA PARA IBIZA 3PTS / ONLY FOR 3 DOORS IBIZA

An Ibiza as the first car is excellent, comfortable, safe, fun and very dynamic to modify. Rudolph has taken a lot of time to customize his.

He installed an Air Design Full Body Kit, a sound system, a set of wheels, Sparco accessories, and a couple of special lights he adapted himself.



SE07B02
3 Doors Rear Spoiler with Diffuser



SE07G01 Front Spoiler

SE07B02

Rear Spoiler with Diffuser

SE06B30

Side Skirts Set



SE06B02 Roof Spoiler

SE06B09*

Door Molding Set

SE06B12* 5th Door Molding

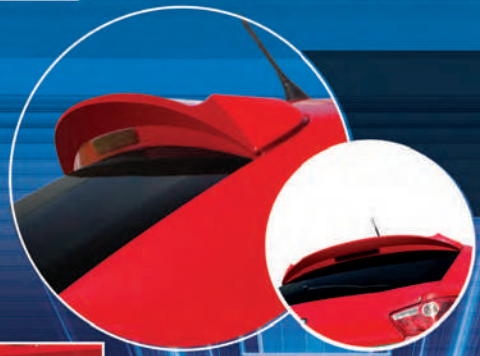

2013-2017 IBIZA 3 PUERTAS



Body Kit with Roof Spoiler

SE07B99

* THESE ACCESSORIES ARE PURCHASED SEPARATELY

SE07G01 Front Spoiler

SE07D03

Rear Spoiler with Diffuser

SE06D10*

Door Molding Set

SE06D31

Side Skirts Set



SE06D01*

5th Door Fastback Spoiler



SE06D03 Roof Spoiler



SE06D13* 5th Door Molding



Body Kit with Roof Spoiler

SE07B98

IBIZA 5 PUERTAS 2013-2017



* THESE ACCESSORIES ARE PURCHASED SEPARATELY



Body Kit with Roof Spoiler (5 pc.)

SE06B99

* THESE ACCESSORIES ARE PURCHASED SEPARATELY



2010-2012 IBIZA 3 PUERTAS

SE06B30

Side Skirts Set



SE06G11

Front Splitters Set

SE06B24

Rear Spoiler with Diffuser

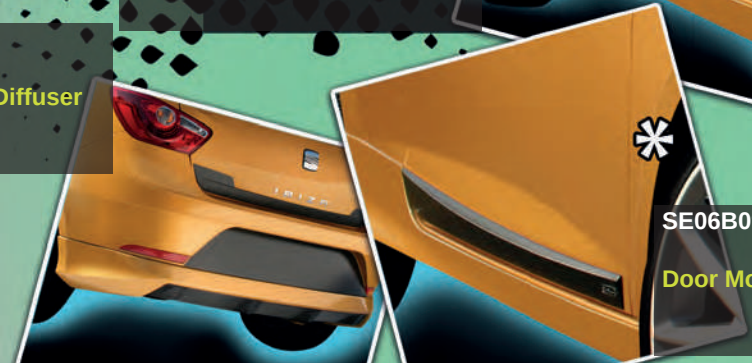

SE06B09*

Door Molding Set



SE06B12*

5th Door Molding



SE06G08*

Front Moldings Set



SE06B02

Roof Spoiler



TOLEDO 2013-2019



Bodykit with Low Profile Rear Deck Spoiler

SE08D98



Body Kit with Wing

SE08D99



SE08D03
Front Spoiler



SE08D04
Rear Spoiler



SE08D07
Side Skirts Set



SE08D01
Rear Deck Spoiler



SE08D02
Wing



SILVER WOLF

TOLEDO 2013-2019

The Toledo is not a Sedan or a Hatchback, it is a Liftback, as its trunk opens together with the rear window.



SE08D02
Wing



Body Kit with Wing-

SE08D99

SE08D01
Rear Deck Spoiler



SE08D04
Rear Spoiler

SE08D07
Side Skirts Set

SE08D01
Rear Deck Spoiler

SE08D03
Front Spoiler with Splitter



Body Kit with Low Profile Rear Deck Spoiler-

SE08D98



When one needs a bigger car, the Toledo becomes an option that is worth considering. Being a Liftback the space is very spacious, but it also owns a daring Turbo engine and excellent dynamic behavior. It was enough to add a set of 18" WCI

wheels with low suspension, and an Air Design Full Body Kit to provide this vehicle with the look and style that many would like to have. 🚗

Road Hunter

Chevrolet Cavalier
2017 - 2019



GET THIS KIT FROM YOUR CHEVROLET LOCAL DEALERSHIP



Rear Deck Spoiler

Rear Spoiler with Diffuser and Decorative Exhaust Tips

Side Skirts Set



Side Skirts Set

Front Spoiler



Rear Deck Spoiler

How is a classic born? Many of the great achievements of brands were not planned, as the birth of the Golf GTI whose creators did it behind VW's back. Convinced that they could improve their car, Michelle knew that with that same philosophy he could dignify the new compact sedan Chevrolet, the Cavalier. She started by changing the wheels for a Rotiform with an angled star design that emulates the 80 'Cavalier. A new firmer suspension, exhaust system, headers, and intake were installed to improve the power of the engine. All these modifications were extremely complemented by a full body kit from Air Design in same Satin Black color which highlighted its modern shapes and aggressive lines. Now Michaelle enjoys going in her classic yet modern car to roads surrounded by beautiful scenery. She travels far and near, from the city to the countryside, and also to perfect places for a good photo shoot. 📸

CHEVROLET CRUZE 2016-2019

BIG STORM



* Available 2019 version

THE CONFORT NEVER LOOKED SO FAST



GET THIS KIT FROM YOUR CHEVROLET LOCAL DEALERSHIP



Front Spoiler with Splitter



Alerón Volado Wing

Side Sklrts Set

Rear Spoiler with Diffuser and Decorative Exhaust Tips

The Cruze is a car that is reinvented, looking for a new and elegant image, changing black plastics by chrome and acquiring a larger air intake with more stylized designs, better finishes, more technology and greater safety.

Air Design Body Kit for Cruze is composed of 5 pieces that integrates harmoniously to these new lines.



Wing

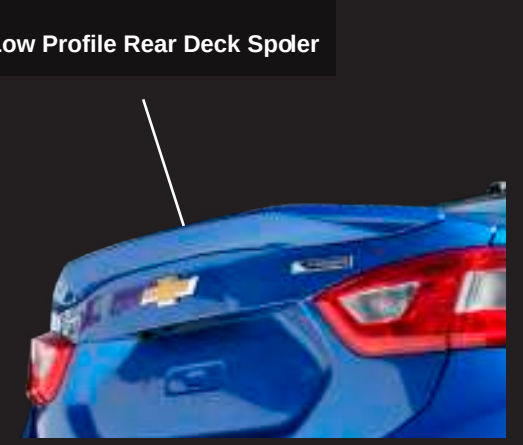

Low Profile Rear Deck Spoiler

RACING

PITS

CRUZE 2013-2015



GM12D16
Front Spoiler

GM12D23*
Bezels Set with DRL LED light



GM12D20
Side Sklrts Set



Body Kit with Low Profile Rear Deck Spoiler-

GM12D95

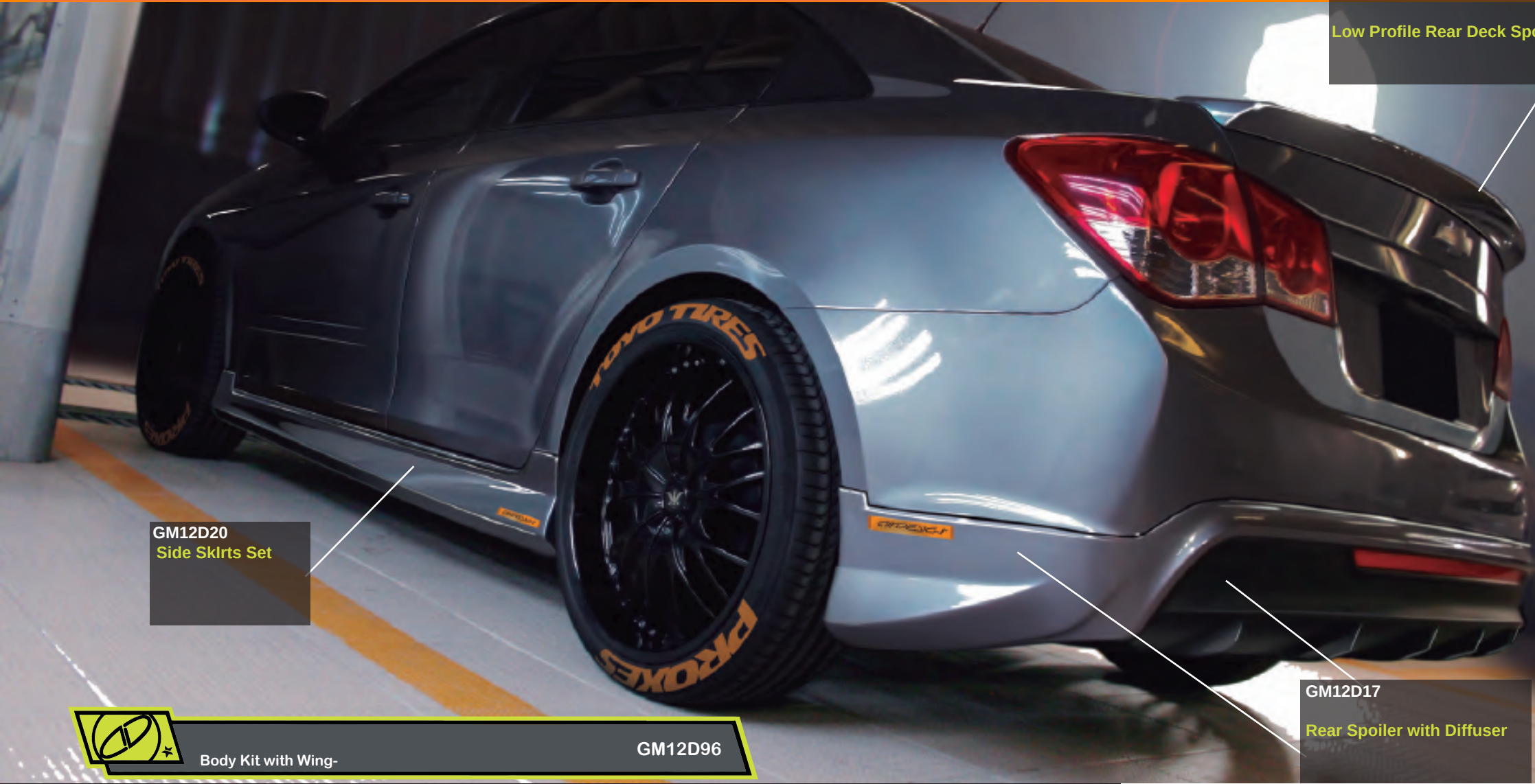

GM12D01
Low Profile Rear Deck Spoiler

GM12D20
Side Sklrts Set

GM12D17
Rear Spoiler with Diffuser



Body Kit with Wing-

GM12D96

“Not everyone can be a racer, but a racer can come from anywhere. I met Jesús at a car show and we became good friends. He told me that he was putting together a race car and he agreed to show it to me. While we were on the way to getting to know the car he told me about all the modifications he made: Air Design Body Kit, competition tires, superlight wheels, a direct exhaust system, forged rods and pistons, modified transmission, low performance suspension, and racing seats. He never mentioned which car he owned, until we get to his garage and I saw his 2013 Cruze I realized that any car could become a great race car.”

Ask us For More Information
SPARCO Original Accessories



CRUZE 2015.5



GM22D06
Front Spoiler



Body Kit with Wing

GM22D98



Body Kit with Low Profile Rear Deck Spoiler

GM22D97



GM12D20
Side Sklrts Set

GM12D17
Rear Spoiler with Diffuser

GM12D01 (2010-2015.5)
Low Profile Rear Deck Spoiler

GM12D02 (2010-2015.5)
Wing

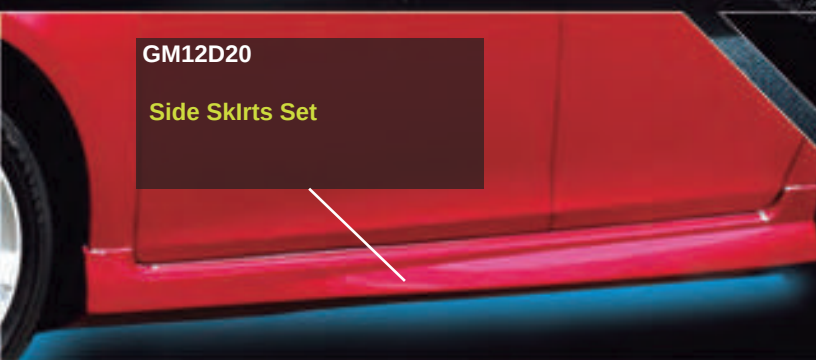

CRUZE 2010-2012



GM12D02 (2010-2015.5)
Wing

GM12D01 (2010-2015.5)
Low Profile Rear Deck Spoiler

GM12D14
Front Spoiler



GM12D01 (2010-2015.5)
Low Profile Rear Deck Spoiler

GM12D07
Side Sklrts Set



GM12D15
Rear Spoiler with Diffuser

Rebel Orange

2017- 2018 SONIC SEDAN



GM29D03
Low Profile Rear Deck Spoiler



Body Kit with Low Profile Rear Deck Spoiler

GM29D99

GM29D02
Rear Spoiler with Diffuser and Decorative Exhaust Tips

GM16D17
Side Skirts Set

GM29D01
Front Spoiler



Body Kit with Wing-

GM29D98

GM29D01
Front Spoiler

“I am very precise, and I also like the striking, that’s why I decided to buy the new Sonic in orange, it has a modern design, a beautiful color, and I could make it look even better, so I put my hands to work and looked for pieces that not only look good, but also add value to the car. I hit the nail with these 17” Vossen wheels with very thin and very wide profile rims, that made a perfect match with the Air Design Body Kit, which by the way is perfect for the car with the same color. I also changed the shock absorbers for the short stem with new springs to lower the height and go, a real bright car.”

DARK SIDE MAY

THE DOWN FORCE BE WITH YOU



GM16D14 Wing

GM16D18 Front Spoiler

GM16D19 Rear Spoiler With Diffuser



GM16D17 Side Skirts Set



Body Kit with Wing-

GM16D98



Body Kit with Low Profile Deck Spoiler-

GM16D95



"From the moment that Chevrolet launched its design for the Sonic I loved it, the front was unique, the design of the headlights with separate sections for each light on a black background had a spectacular effect. I liked it so much that I decided to buy it and play with its lines to create a special car, based entirely on black so that its lines



were what stood out and not the color. I installed the Air Design Body Kit with Wing which added a very few aesthetic detail. I also installed low suspension and Vossen wheels that combine lines in aluminum with black background, I managed to have a very precise combination".

FORBIDDEN FRUIT

CHEVROLET SONIC HB 2012-2016

Ask us for more Information
SPARCO Original Accessories



GM16D18
Front Spoiler

GM16D17
Side Skirts Set



Andy waited a long time for the Chevy Sonic, he loved the frontal appearance of it but he needed an HB for space. Even before getting his car from the dealership he started buying parts for it, and by the time he finally bought it, he already had, in his possession, some Sparco seats with 4-point belts, 17" Progressive wheels with low profile rims, coilovers and a Body Kit from Air Design. The next step was to assemble and install all the pieces onto his new car. Andy didn't travel 20 miles with his original parts! He was commissioned to assemble each piece the same, which included the seats, wheels, belts, body kit, coilovers and all the other small accessories. Everything fit perfectly, the only adaptation was the seat but the Sparco universal seat bases fitted perfect with his car. 🏆

GM16E20
Roof Spoiler



Body Kit with Roof Spoiler-

GM16E97



GM16E21
Rear Spoiler with Diffuser



GM06E07

Roof Wing

*3 Puertas / 3 Doors



GM06C06

Roof Wing

*5 Puertas / 5 Doors



GM06D21

Front Bumper Reemplacement Competition

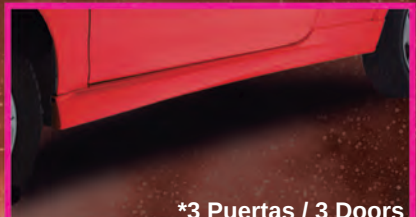

*3 Puertas / 3 Doors

GM06C25

Side Skirts Set



*3 y 5 Puertas / 3 and 5 Doors

GM06J40

Rear Spoiler with Diffuser

CHEVY

C3 HATCHBACK
2008-2012



MATIZ

2006-2015



GM17E01
Roof Spoiler

GM06D21

Front Bumper Reemplacement Competition



GM06D41

Rear Spoiler with Diffuser



GM06D05
Wing



GM06K26

3 and 5 Doors Side Skirts Set

Chevy C3

Sedán

2008-2012



SUPER LIFE

CHEVROLET SPARK NG 2017-2019

I like to modify cars, I dedicate my life to it. I've worked hard to open up my own workshop and modify as many cars as possible. At the same time I decided to build my own car. I remember the excitement of receiving each piece, the desire to see the finished project. I mounted a set of Vossen wheels, ceramic brakes to match its Airlift and a Body Kit I got from Air Design and that was sent by them matching the exact color of my car. LED lights were also put in. I had to created all the exhaust system and air induction by hand. There's no better feeling than knowing that you build your own car! 🏆



* Available 2019 version

Front Spoiler with Splitter

Roof Spoiler

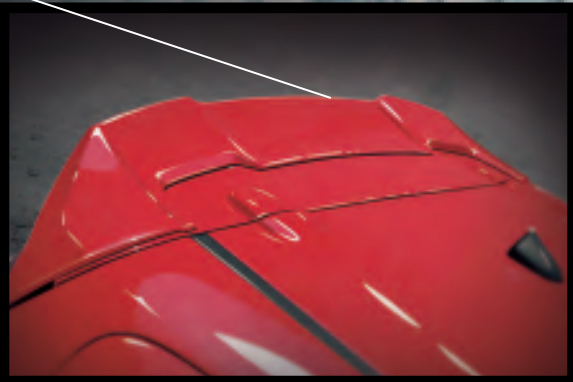

Rear Diffuser



GET THIS KIT FROM YOUR CHEVROLET LOCAL DEALERSHIP

Roof Spoiler



Front Spoiler with Splitter

Side Skirts Set

Three Body Kit

CHEVROLET SPARK 2013-2016

Mario is dedicated to personalizing items and cars through vinyl. He decided that his car should reflect his personality that he could provide with his line of work. The first step was to eliminate the rear seats to have cargo space appropriate to their needs and then proceeded to start working on the design. The design was achieved by combining its wrap with black and dark orange matte colors, and its Air Design Body Kit was also customized with glossy black, giving the car a unique personality that reflects the work and soul of Mario.

GM18E01
Roof Spoiler



GM18E95
Body Kit with Roof Spoiler-

APLICA PARA SPARK 1LT Y CLASSIC / ONLY FOR SPARK 1LT AND CLASSIC

GM18E01
Roof Spoiler

GM18E07
Side Skirts Set

GM18E02
Front Spoiler with Splitter for 1LT and Classic

GM18E02
Front Spoiler with Splitter for 1LT and Classic



#ADSTICKERS
 CARWRAP
 BORDADOS
 SUBLIMACIÓN
 ROTULACIÓN
 E IMPRESIÓN
 DIGITAL
 GRABADO Y CORTE
 LASER
 Tl. 58774606
 Cd. SS 13 8191 22

SPARK 2LT

2013-2016

SPARK 2LT 2013-2016



Ask us For More Information
SPARCO Original Accessories

Styling his car was extremely easy for Rogelio. At Air Design, Rogelio found a Body Kit created specifically for his Spark 2LT, without any adaptation, just a plug & play! He was extremely happy with his Body Kit and its unique style!



GM18E03
2LT Front Spoiler
2LT



Body Kit with Roof Spoiler-

GM18E99

APLICA PARA SPARK 2LT / ONLY FOR SPARK 2LT

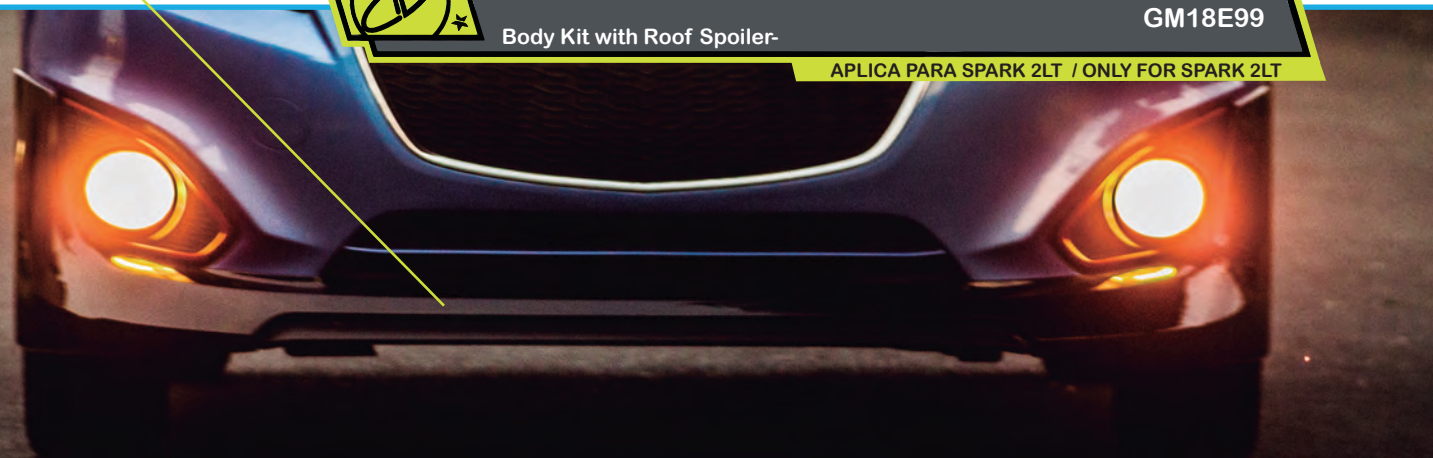

GM15E08
Front Spoiler

GM15E06*
Door Molding Set

GM15E02
Rear Diffuser

SPARK 2011-2012



GM15E01
Roof Spoiler

GM15E05
Side Skirts Set



GM15E07*
Rear Ligths Molding Set

These accessories are purchased separately



Body Kit with Roof Spoiler-

GM15D98

SPARK

2011-2012

el mas grande VIVE AVENTURAS

TOY LAND

BEAT HB 2018-2019



GET THIS KIT FROM YOUR CHEVROLET LOCAL DEALERSHIP



Side Skirts Set

Front Spoiler with Splitter



Alerón de Techo
Roof Spoiler



Side Skirts Set

Rear Diffuser

For a lot of us, when we were younger our passion for cars started with collecting toy cars, they brought us joy and we thought they were so cool. That was a time that required a very worthy tribute, so Max decided to make this Beat that tribute. He acquired some 17" Fifteen52 wheels with a friendly design with very low profile rims. The next step was to add white lights to match the color of the body and the Body Kit made by Air Design in Satin Black finish, making it a car that invites you to play with it. Fun, agile and always ready for the adventure. 🏁

THE BIG FISH

BEAT NB 2018-2019



Side Skirts Set

Front Spoiler with Splitter



GET THIS KIT FROM YOUR CHEVROLET LOCAL DEALERSHIP



Rear Desk Spoiler

Rear Spoiler with Diffuser and Decorative Exhaust Tips

Side Skirts Set



Rear Deck Spoiler

This car was based on the designs of Asia, where its aesthetic relates to the legendary Koi fish. The Koi is a small fish that becomes strong when swimming against the current, famous for its red, orange and white colors and also for resembling its head of the mythological dragon. This car is just like that, small but with enough power to overcome the asphalt jungle. A car that becomes stronger with details like its new wheels, adjustable suspension and an Air Design Body Kit that enhances a strong and aggressive design, that makes the Beat our big fish. 🐉



FREE

SPIRIT

AVEO (SAIL) 2018



Side Skirts Set

Front Spoiler with Splitter



Rear Deck Spoiler

Rear Spoiler with Diffuser and Decorative Exhaust Tips

Rear Deck Spoiler



GET THIS KIT FROM YOUR CHEVROLET LOCAL DEALERSHIP



The Aveo was always a traditional, simple, practical car, but in this new generation it changed its personality, becoming also a daring free-spirited car, which acquires much more presence with small modifications. We modified this wine-colored Aveo with an Air Design Body Kit that combines the original color with Satin Black and 18" polished aluminum finish wheels with air suspension.





Body Kit with Low Profile Rear Deck Spoiler-

GM32D99

GM32D01

Low Profile Rear Deck Spoiler

GM02D13

Side Skirts Set

GM02D07

Rear Spoiler with Diffuser

There are cars that people praise for their versatility, endurance, agility, and space. Beloved cars that people practically demands from the manufacturers. just like the VW Sedan which was produced in Mexico until 2003, the Nissan Sentra B13 until 2017, or the Combi until 2014 in Brazil. The Chevrolet Aveo has joined that list of cars appreciated by the people, lasting 10 years with very few changes. Its latest refreshing features more sports lines which have been retaken by Air Design for the Body Kit shown in this page. 

ON THE JOURNEY

AVEO 2017.5



GM02D13

Side Skirts Set

GM32D02

Front Spoiler with Splitter

2012 - 2017 AVEO



GM02D19 (2012-2016)
Front Spoiler



GM02D07 (2012-2017.5)
Rear Spoiler with Diffuser



GM02D13 (2008-2017.5)
Side Skirts Set



GM02D02 (2008-2017.5)
Wing



GM02D01 (2008-2017.5)
Profile Rear Deck Spoiler



TRAX 2014-2016



Body Kit

GM21E99



GM21E01
Front Bumper Guard



GM21E07
Roof Spoiler



GM21E23
Moldings
Door Set





GET THIS KIT FROM YOUR CHEVROLET LOCAL DEALERSHIP



Side Skid Plate Set

Door Moldings Set

Front Bumper Guard with Sid Plate



Our parts are made of the highest quality polyurethane, which gives them flexibility and resistance

Rear Bezels Set



In a city of chaos you need to always be in control, you need a large space but an adequate size to park in the tightest places. Alexa's Chevy Trax meets such a challenge and still keeping an amazing look. Using a 19"chrome Rotiform concave wheels, wide tires, and a matte black Air Design Body Kit with aluminum details that stand out on the nautical blue body color, it becomes one of the most beautiful SUV around.

WILD CITY

EVERYTHING IS ABOUT YOU

TRAX 2017
2019



Roof Spoiler



Side Skid Plates Set

Rear Skid Plate

THE ADVENTUROUS



RH Side Skid Plate



Front Skid Plate



Roof Spoiler

Fender Flares Set

LH Side Skid Plate

Rear Skid Plate

This is undoubtedly one of the most amazing SUV that one could find around the city. Its 4-cylinder engine gives it enough power to furrow across the asphalt jungle with surprising ability while maintaining comfortable its occupants. It definitely does not lack of styling. The Air Design

Body Kit in Aluminum and Satin Black finishes integrates perfectly to these elements, keeping the elegance of this SUV design. Its double exhaust tips molded in the Rear Skid Plate provides this vehicle with the sophistication and solidity essential for its segment.

2018- 2019 CHEVROLET EQUINOX



GET THIS KIT FROM YOUR CHEVROLET LOCAL DEALERSHIP

PERFORMANCE

ACCESSORIES FOR STREET CARS AND TUNING



Asientos de Calle
Cinturones
Volantes de Calle
Palancas
Tapetes y Posapies
Filtros de Aire
Tapas para gasolina
Seguros para cofre
Merchandising

Street Seats
Harnesses
Street Steering Wheels
Gear Knobs
Floor carpets and foot rests
Air Filters
Fuel caps
Hood Pins
Merchandising

OFFICIAL SUPPLIER FOR YOUR PASSION

sparco



ECE 22.05

SPRINT

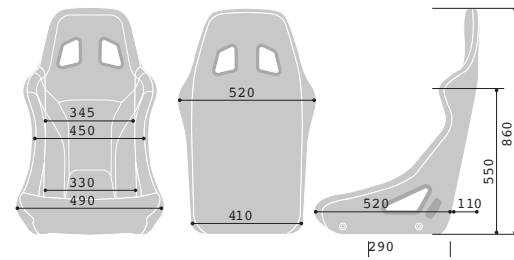

008235NR 008234LNR 008234LRS

The Sprint seat has a tubular steel frame with an elastic backrest and seat structure. Homologated with holes at the bottom and lateral fixing for 5 or 6 straps belts.



Tubular steel chassis. Fixing points 271 x 345 mm. Compatible with 3 and 4 points safety harnesses. 3D fabric for improve breathability.

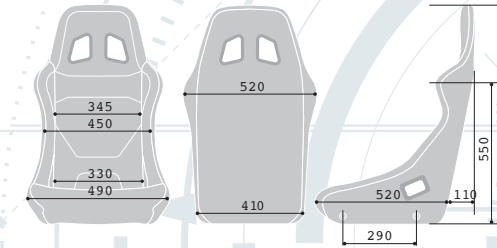

F200



R600

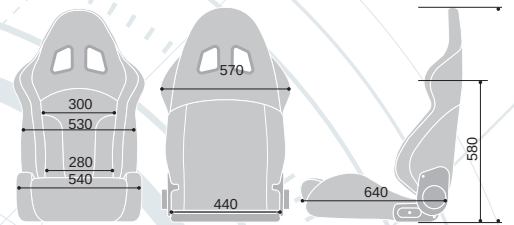

Tubular steel frame. New micro seat back regulation, similar to top supercars. Ergonomic and comfortable padding. Covering in Jacquard Quick Tilting lever. Lower fixing 271 x 345 mm. Compatible with 3 and 4 points safety harnesses.

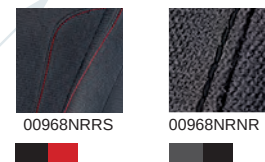

R100



R100 SKY

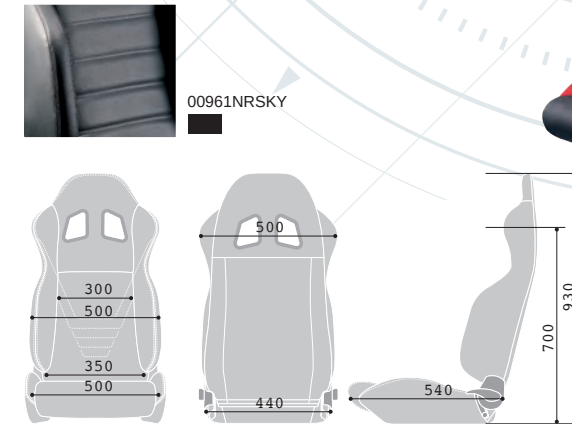

R100/ R100 SKY



R333

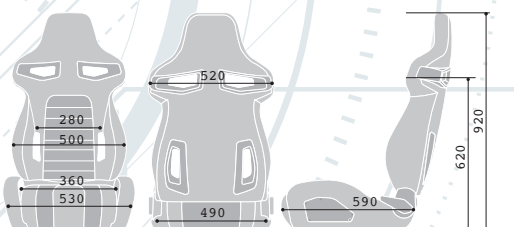

Tubular frame. Double adjustment and reclining lever. bottom fixing 271 x 345 mm. Compatible with 3 or 4 fixing point harnesses.



SET OF SLIDE RUNNERS
 Longitudinal distance 271 mm.



Distance between holes 290 mm. Max length 400 mm. Simple mounting in the car with more than 25 positions. 3 mm black powder coated, FIA compliant. M8 mounting kit included.

04604 BM1



Homologation: ECE

- 04604BM1AZ
- 04604BM1NR
- 04604BM1RS
- 04604BM1GR

4 fixing points, snap on, lap reinforcement.

04608 DF1

SPORT

Homologation: ECE

- 04608DF1AZ
- 04608DF1NR
- 04608DF1RS
- 04608DF1GR

3 fixing points, double buckle, snap on and lap reinforcement.



- 01090S4AZ
- 01090S4RS
- 01090S4NR
- 0109077BIAZ
- 0109077AZ
- 0109077RS
- 0109077NR

77

04604 BV1



4 fixing point by bolt with lap reinforcement.

Homologation: ECE

- 04604BV1AZ
- 04604BV1NR
- 04604BV1RS
- 04604BV1GR

04608 BV1

GT

Homologation: ECE

- 04608BV1AZ
- 04608BV1NR
- 04608BV1RS
- 04608BV1GR

3 bolted fixing points.



- 01090R3AZ
- 01090R3RS
- 01090R3NR

Pair of pads in Alcantara® with high grip neoprene inner layer. Useful to improve comfort of driving when fitted on steering wheels or hand-brake handle.

MINI

- 01099NR
- 01099RS
- 01099AZ

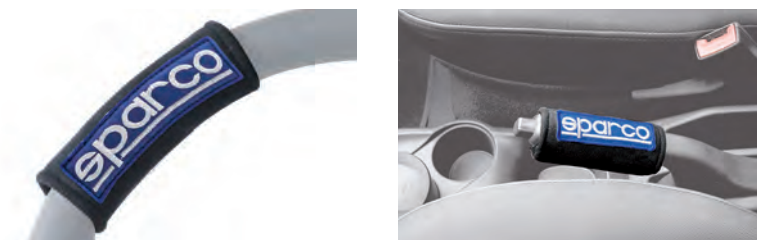

L777



Leather - Piel
015L800PL

Suede - Ante
015L800SC

L575



Leather - Piel
015L750PL

Suede - Ante
015L750SC

L999



Leather - Piel
015TMG22TUV

L360



Leather - Piel
015TRGL1TUV

Suede - Ante
015TRGS1TUV

L550



Leather - Piel
015TMZL9

Suede - Ante
015TMZS1

L505



Leather - Piel
015TL522TUV

L575

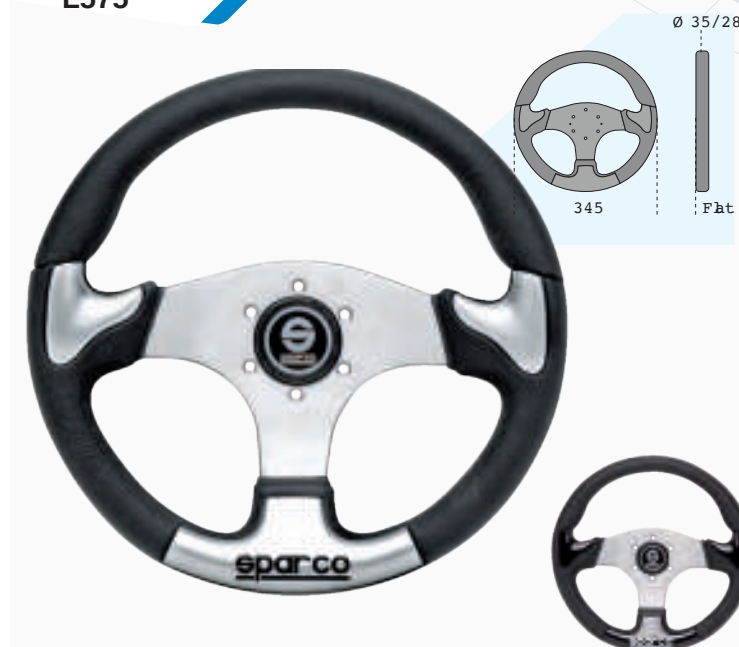

Leather - Piel
015THPUGR345

Suede - Ante
015THPUNR345



PIUMA



Lightened grey/black gear knob.

03741BN01 03741BT01



SETTANTA



Titan/black two colour gear knob.

03736A 03736AO1



SETTANTA R



03737TS 03737NS

Titan/black two colour gear knob for reverse gear.

RACING



037401CL

SPEED



03744PTN

TECNO



03747PTN

TRALICCIO

Universal mounting on all gear stick with a max diam. 15 mm. Not suitable for gearbox with syringe safety stop. Made by aluminium.



Drilled gear knob with sphere handgrip.

037401CR 037401AN



DRIFTING



03735NR
HAND BRAKE LEVER

Aluminum hand brake lever. Black aluminum tube, with anti-slip o-ring. Height adjusting up to +15 cm with additional part. Fitting diameter: 20 mm.

Chromed gear knob with leather insert.



GLOBE
03745PTN

HYDRAULIC BRAKE LEVER

Hydraulic brake lever, Girling compatible. Horizontal or vertical fitting (uniball adjusting). 20 mm tube. Cap, Uniball and Girling are sold individually.



037521FPLNR

GEAR KNOB

Aluminum gear knob standard (not suitable for syringe engagement). Black or anodized aluminum tube, with anti-slip o-ring. Height adjusting (more than 10 cm with additional part. Complete with screws and instructions. Fitting diameter: 15 mm.



03734NR

Chromed or wrapped in perforated leather gear knob.

Perilla para palanca cromada o vestida en piel.



03747CR

Homologation: ECE



037879BC01

Set of universal pedals.



037879BT01



037879IT01

Homologation: ECE

Lightened universal black or silver pedal.



037879OP01

Set of pedals, long accelerator pedal.



037879OP04

REFLEX



0378713

Reflex kit universal pedals, ECE.



03753TI



03753NR

Universal hand brake.

FUEL CAPS

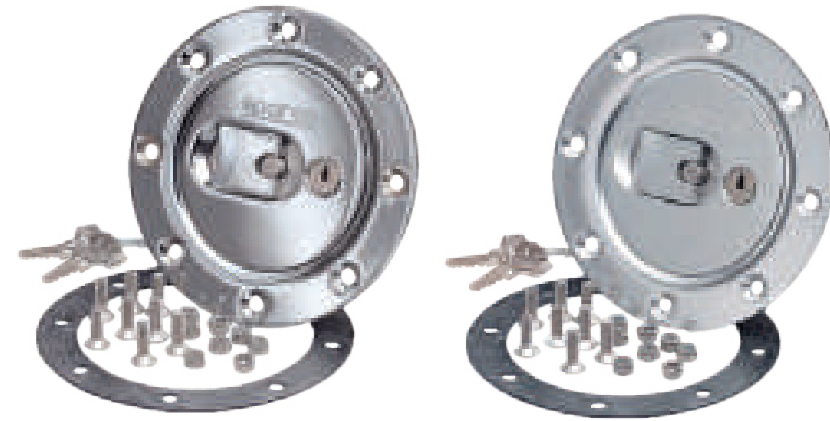

27004CR

27004OA

Developed in a special aluminium alloy through an innovative forging technology, and trimmed with CNC machine computer numerical control to obtain the perfect coplanar surface. They are heat treated to increase the mechanical resistance and then they are anodized to prevent oxidation. Fits on the most popular vehicles, bolts and studs come included.



27009G

HP300

Universal air filter. Intended for cars which performance goes up to 300 bhp. Includes universal assembly kit. Requires some modifications on the air intake assembly.

030HP300



Universal air filter. Intended for cars which performance goes up to 160 bhp. Includes universal assembly kit. Requires some modifications on the air intake assembly.

HP160

030HP160



030HP003



HP300 Filter
Filtro de aire
HP300



HP300 Filter
Filtro de aire
HP300

030HP002



030HP001

Connector tube for HP300 and HP160.

CUBRE ESTRIBOS



Set of 2 sill guard 3D flexible adhesive.

605 x 35 mm

450 x 35 mm

03769A

03769B



Carbon sill guard 3D flexible adhesive.

605 x 35 mm

450 x 35 mm

03770CARBON

03769CARBON



FUELLE PARA PALANCA



Gear knob gaiter in ecological leather with Sparco embroidered logo.

037541NRRS

037541NRAZ

037541NRAR



RELOJES



099014BM

099013NR

099014RS

099016VI

099017NR



01606S

01606AA

01606AR

Pair of stainless steel bonnet pins with captive slide pin.

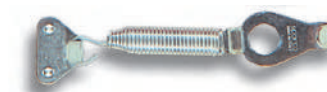

01608

Pair of stainless steel spring hooks.

CIERRES COFRE

MARKETING

sparco



Michel Betancourt

- 1st. place at International Grand Prix, México City

- 1st. place at Santiago Race Track, Monterrey

- 1st. place at Bosque Real Cup, México City

Flame retardant fabric racing suits (Nomex)
Underwear
Karting Rib Protectors
Helmets
Racing Shoes
Racing Gloves
Accessories for Karts

OFFICIAL SUPPLIER FOR YOUR PASSION



RACING

sparco

OFFICIAL SUPPLIER FOR YOUR PASSION



- Flame retardant fabric racing suits (Nomex)
- Underwear
- Racing Seats
- Harnesses
- Hans Device Collars
- Helmets
- Racing Steering Wheels
- Racing Shoes
- Racing Gloves
- Intercom Amplifier
- Accessories for Mechanics
- Roll Cages



THE PERFECT TERRAIN

2018-2019



-SPOILER DELANTERO - FRONT SPOILER

Learn more about fender flares we have.