



Engineered to Deliver

**THE ULTIMATE LINE OF PROFESSIONAL
CARGO MANAGEMENT SYSTEMS**



2016

TracRac® ...THE DETAILS OF DESIGN

ALUMINUM CONSTRUCTION is lightweight and strong

- 6000 series aluminum; common in aerospace and marine applications
- Occupies less payload capacity than competitive racks
- Will never rust
- Cast aluminum components increase strength and rigidity

DURABLE POWDER COAT finish for superior quality

- Electrostatic powder coating produces harder and tougher finish

AERODYNAMIC for a quiet ride

- Noise reducing crossbar extrusion contains aerodynamic profile to eliminate whistle from crossbar slots
- Uniquely shaped aluminum cast components lowers wind noise and improves racks aesthetics

USA MADE to ensure quality

- Products are built in an ISO 9000 Certified manufacturing facility
- The Seymour, Connecticut factory employs talented local labor to ensure products are manufactured to the highest standards

TESTED by a LIFETIME WARRANTY

- Validation testing of our products to 150% of rated strengths simulate over 20 years of operation
- OEM approved by top domestic automotive/truck manufactures
- U-channel bed protectors and rubber cushioning strips are designed to protect the bed of your vehicle from damage during installation and usage





Engineered to Deliver

Contents

Rack Systems

TracRac® SR	4
T-Rac® Pro2™	8
TracONE™	10
Universal Steel Rac	12
Utility Rac™	14
Contractor Steel Ladder Rack	15
TracVan® ES	16
TracVan®	17
CapRac™	18

Accessories

Optional Accessories	19
----------------------------	----

TracRac® SR

THE ULTIMATE SLIDING RACK SYSTEM

TracRac® SR is engineered to maximize the functionality of your truck. You can slide the racks into any position along the base rails for different size loads and add accessories for extra capacity, storage configuration or tie-down points. **TracRac® SR conforms to your needs.**

Complete System: 21000 Series Base Rails & 43000 Series Overhead Racks

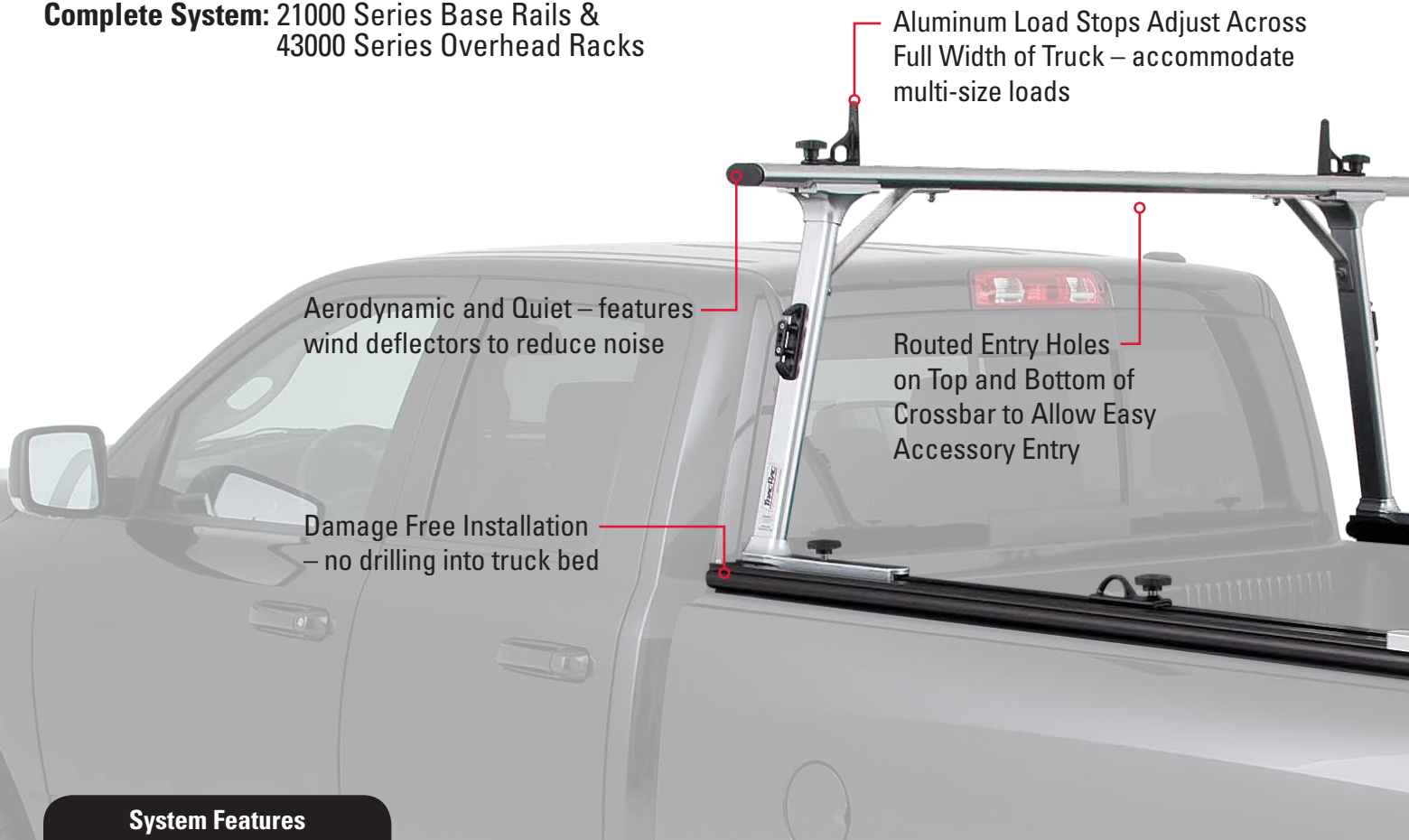

Aluminum Load Stops Adjust Across Full Width of Truck – accommodate multi-size loads

Aerodynamic and Quiet – features wind deflectors to reduce noise

Routed Entry Holes on Top and Bottom of Crossbar to Allow Easy Accessory Entry

Damage Free Installation – no drilling into truck bed

System Features

Base Rails Includes	<ul style="list-style-type: none">• 2 Black Anodized Aluminum Base Rails• Drill-free Mounting Hardware
Over Head Racks Includes	<ul style="list-style-type: none">• Front and Rear Sliding Racks• 4 Sliding Aluminum Crossbar Load Stops• 4 Aluminum ARC Side Cleats• Pre-assembled Uprights
Load Capacity	<ul style="list-style-type: none">• 1250 lbs.* <i>*When evenly distributed across both racks and installed correctly.</i>
Weight	<ul style="list-style-type: none">• 55 lbs. (Over Head Racks), 20 lbs. (Base Rails)
Finish and Material	<ul style="list-style-type: none">• Durable Powder Coat Finish• 100% Rust Free Aluminum



Black Anodized Aluminum Base Rails



Expansion Block Stake Pocket Mounts



Sliding Racks Adjust Along Full Length of Bed to Carry Different Loads and Can Easily Be Removed When Needed



Aluminum Crossbar Endcaps
– assist load retention

Aluminum ARC Side Cleats
– provide additional tie-down points

Internal Web Structure on Crossbar for Increased Strength

Corner Brace Design Improves Rack Stability and Performance

Utilizes TracRac's Modular Design Platform – increased strength and flexibility

Technical Specifications

Materials	<ul style="list-style-type: none"> – Core Components: 6063 T-6 Aluminum – Hardware: 304/18-8 SS or Coated Steel Meeting GM Specification GMW4700
Coatings	<ul style="list-style-type: none"> – Core Components: Electrostatic Powder Coating 2.0-4.0 mils thickness tested to ASTM B117 – Base Rails: Black Anodized
Performance Characteristics	<ul style="list-style-type: none"> – Load Rated for 1,250 lbs. Evenly Distributed
Cross Bar T-Slot Dimensions	<ul style="list-style-type: none"> – Slot Opening Width: .393" – Slot Base Width: .720" – Slot Height: .275"
Physical Features	<ul style="list-style-type: none"> – Bullet Shaped Crossbars - Aerodynamics – Air Foil Trip Strip at Front of Crossbar – Reduces Noise – Tri-Directional Aluminum ARC Cleat Located on Outside of Uprights – Unique Saddle Base Slider Construction Shape Increase Strength and Rigidity – Rubber Expansion Block Stake Pocket Mounts with Aluminum Compression Nuts – Corner Brace Design Improves Rack Stability and Performance

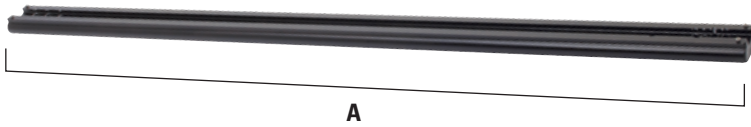

Base Rails

Part Number	Description	Dimensions (inches)		
		A	B	C
21000	Base Rail (Fullsize longbed trucks)	96.9	4.0	1.9
21010	Base Rail (Super Duty longbed)	96.9	4.0	1.9
21011	Base Rail (2007 Tundra Longbed)	96.9	4.0	1.9
21501	Base Rail (Fullsize shortbed trucks)	77.5	4.0	1.9
21505	Base Rail (Tundra - Short Bed)	75.3	4.0	1.9
21508	Base Rail (F-150 Super Crew)	65.6	4.0	1.9
21510	Base Rail (Super Duty shortbed)	81.5	4.0	1.9
21600	Base Rail (Compact shortbed)	73.0	4.0	1.9
21603	Base Rail (Nissan Crew Cab)	57.0	4.0	1.9
21606	Base Rail (Nissan Titan Crew Cab)	65.8	4.0	1.9
21608	Base Rail (GMC Crew Cab)	68.0	4.0	1.9
21610	Base Rail (2007 Tundra Shortbed)	77.5	4.0	1.9
21611	Base Rail (2007 Tundra XShortbed)	65.4	4.0	1.9
21780	Base Rail (14- Silverado/Sierra Long Bed)	96.9	4.0	1.9
21781	Base Rail (14- Silverado/Sierra Short Bed)	77.5	4.0	1.9
21782	Base Rail (14- Silverado/Sierra XShort Bed)	68.0	4.0	1.9
21783	Base Rail (15- Colorado/Canyon Short Bed)	73.0	4.0	1.9

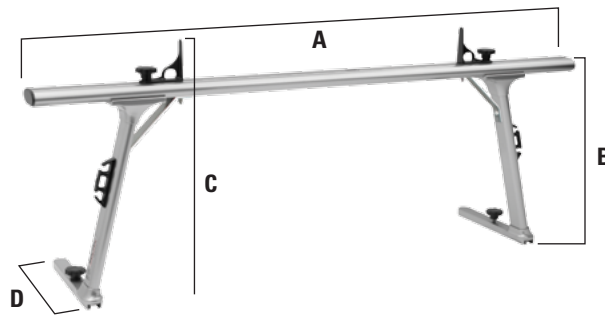

Overhead Racks

Part Number	Description	Dimensions (inches)			
		A	B	C	D
43001	Overhead Racks - SR - Compact	65	23.27	27.76	16
43002	Overhead Racks - SR - Fullsize	69.5	25.4	29.9	16
43003	Overhead Racks - SR - Super Duty/Dodge Ram	69.5	27.03	31.53	16



ACCESSORIES

See page 19 for information about accessories.



Engineered to Deliver



T-Rac® Pro2™

THE PROFESSIONAL'S CHOICE

Built with professionals and truck enthusiasts in mind, the **T-Rac® Pro2** has the functionality and accessories you need to transport cargo and materials. The **T-Rac® Pro2** features pre-assembled uprights and a 1,000 lbs. load capacity.

Aerodynamic and Quiet – features wind deflectors to reduce noise

Aluminum Load Stops Adjust Across Full Width of Truck – accommodate multi-size loads

Routed Entry Holes on Top and Bottom of Crossbar to Allow Easy Accessory Entry

Strong and Secure Universal Mounting Clamps with Integrated Toolbox Mount

System Features

System Includes

- Front and Rear Powder Coated Aluminum Racks
- 8 Single Axis Mounting Clamps
- 2 Toolbox Mount Clamps
- 4 Sliding Aluminum Crossbar Load Stops
- 4 Aluminum ARC Side Cleats
- Pre-assembled Uprights

Load Capacity

- 1,000 lbs.* **When evenly distributed across both racks and installed correctly.*

Weight

- 55 lbs.

Finish and Material

- Durable Powder Coat Finish
- 100% Rust Free Aluminum

Product Dimensions

Part Number	Description	Dimensions (inches)			
		A	B	C	D
37001	T-Rac Pro2 - Compact	65.00	25.38	29.88	16
37002	T-Rac Pro2 - Fullsize	69.50	27.25	31.75	16
37003	T-Rac Pro2 - Super Duty/Dodge Ram	69.50	29.15	33.65	16
37004	T-Rac Pro2 - Tacoma 2005-2015	65.00	25.38	29.88	16
37005	T-Rac Pro2 - Tacoma 2016 -	65.00	25.38	29.88	16

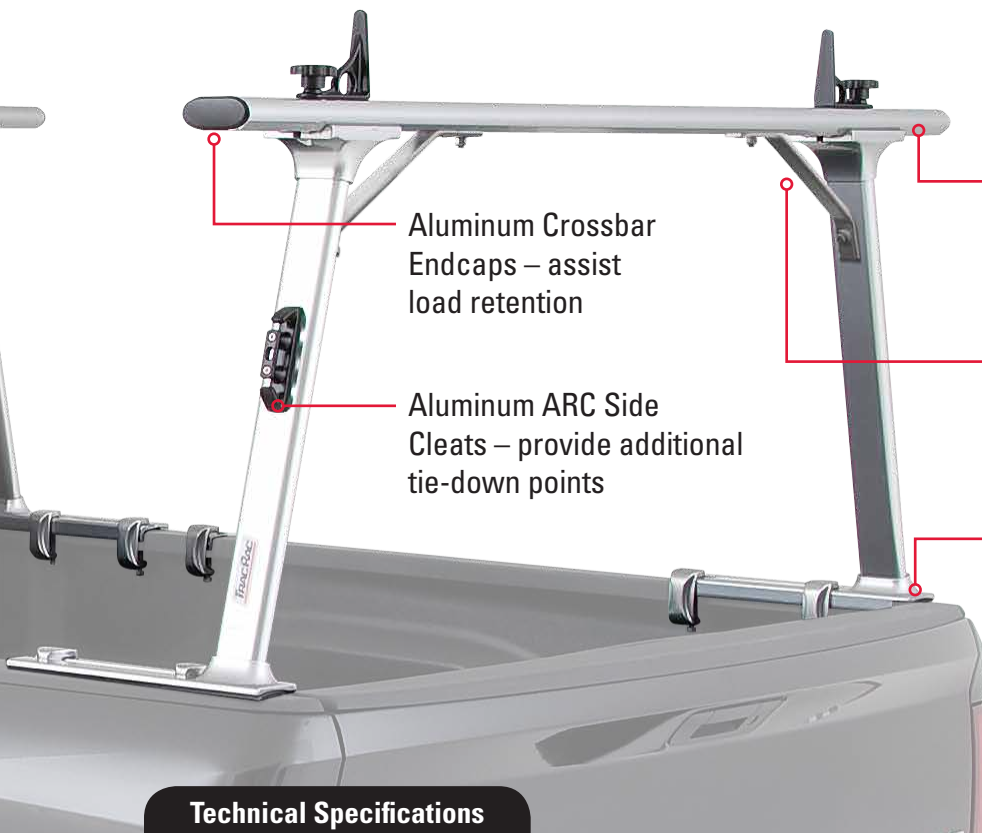
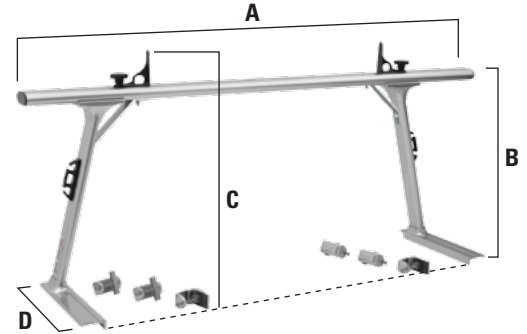

Aluminum Crossbar Endcaps – assist load retention

Aluminum ARC Side Cleats – provide additional tie-down points

Internal Web Structure on Crossbar for Increased Strength

Corner Brace Design Improves Rack Stability and Performance

Utilizes TracRac's Modular Design Platform – increased strength and flexibility

Technical Specifications

Materials	<ul style="list-style-type: none"> – Core Components: 6063 T-6 Aluminum – Hardware: 304/18-8 SS or Coated Steel Meeting GM Specification GMW4700
Coatings	– Core Components: Electrostatic Powder Coating 2.0-4.0 mils thickness tested to ASTM B117
Performance Characteristics	– Load Rated for 1,000 lbs. Evenly Distributed
Cross Bar T-Slot Dimensions	– Slot Opening Width: .393" – Slot Base Width: .720" – Slot Height: .275"
Physical Features	<ul style="list-style-type: none"> – Bullet Shaped Crossbars - Aerodynamics – Air Foil Trip Strip at Front of Crossbar – Reduces Noise – Tri-Directional Aluminum ARC Cleat Located on Outside of Uprights – Unique Saddle/Base Construction Shape Increase Strength and Rigidity – Single Axis C-Clamps with Aluminum U-Channel for Bed Protection and Integrated Toolbox Mount – Corner Brace Design Improves Rack Stability and Performance

TracONE™

THE UNIVERSAL TRUCK RACK

The **TracONE™** is the perfect rack for those occasions when you need to carry ladders, lumber or other long items that just won't fit in your truck bed.

*Also available in
Matte Black finish*



Aerodynamic and Quiet – features wind deflectors to reduce noise

Internal Web Structure on Crossbar for Increased Strength

Easy to Install Universal Mounting Clamps

System Features

System Includes	<ul style="list-style-type: none">• Front and Rear Powder Coated Aluminum Racks• 8 Single Axis Mounting Clamps• 4 Adjustable Crossbar Loop Tie-downs
Load Capacity	<ul style="list-style-type: none">• 800 lbs.* <i>*When evenly distributed across both racks and installed correctly.</i>
Weight	<ul style="list-style-type: none">• 50 lbs.
Finish and Material	<ul style="list-style-type: none">• Durable Powder Coat Finish• 100% Rust Free Aluminum
Fit Kits* <i>* Kits only available in Silver color</i>	<ul style="list-style-type: none">• Toyota Tacoma Mount Kit: 34000 (2005-2015) 34001 (2016-)• Toyota Tacoma Mount Kit with Toolbox Mount: 41500 (2005-2015) 41501 (2016-)• Compact/Fullsize Truck Toolbox Mount Kit: 41000

Product Dimensions

Part Number	Description	Dimensions (inches)			
		A	B	C	D
27000-01	TracONE	65.00	26.23	28.92	16
27000B	TracONE - Matte Black	65.00	26.23	28.92	16

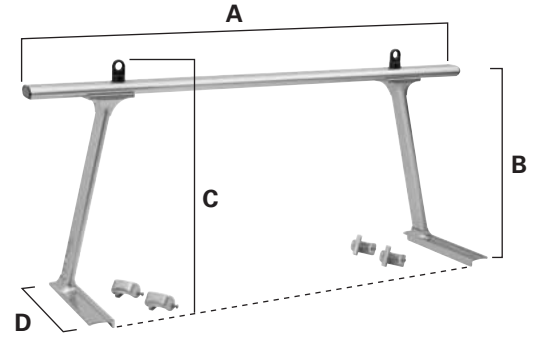

Technical Specifications

Materials	<ul style="list-style-type: none"> - Core Components: 6063 T-6 Aluminum - Hardware: 304/18-8 SS or Coated Steel Meeting GM Specification GMW4700
Coatings	<ul style="list-style-type: none"> - Core Components: Electrostatic Powder Coating 2.0-4.0 mils thickness tested to ASTM B117
Performance Characteristics	<ul style="list-style-type: none"> - Load Rated for 800 lbs. Evenly Distributed
Cross Bar T-Slot Dimensions	<ul style="list-style-type: none"> - Slot Opening Width: .393" - Slot Base Width: .720" - Slot Height: .275"
Physical Features	<ul style="list-style-type: none"> - Bullet Shaped Crossbars - Aerodynamics - Air Foil Trip Strip at Front of Crossbar - Reduces Noise - Unique Saddle/Base Construction Shape Increase Strength and Rigidity - Single Axis C-Clamps with Aluminum U-Channel for Bed Protection

Universal Steel Rac

THE UNIVERSAL STEEL TRUCK RACK

Outfit your truck to work harder so you don't have to. With up to 1,000 lbs. load capacity, the Universal Steel Rac will handle the toughest of jobs. Corrosion resistant powder coated steel tubing and adjustable hardware make for easy installation on almost every fullsize truck from Chevrolet, Dodge, Ford, GMC, Nissan and Toyota. **Best of all, we make it right here in the USA.**

Robust 1 5/8" Round Steel Tube
– provides strength and reduces wind noise

Superior Durability and Corrosion Resistance with Powder Coat Finish

Adjustable Design – fits all Full Size pickup trucks with 5' to 8' bed length

System Features

System Includes	<ul style="list-style-type: none">• Powder Coated Steel Full Frame Rack• 4 Adjustable Uprights• 8 Powder Coated Steel Adjustable Mounting Clamps• 1 Removable Rear Load Bar• 4 Integrated Steel Tie-Down Cleats
Load Capacity	• 1,000 lbs.* <i>**When evenly distributed. Vehicle may limit carrying capacity.</i>
Weight	• 140 lbs.
Finish and Material	• Durable Powder Coat Finish

Product Dimensions

Part Number	Description	Dimensions (inches)						
		A	B	C	D	E	F	G
91000	Universal Full Frame Steel Rack	54.50	27.75	33.00	17.00	148.00	56.00 – 97.00	61.50 – 67.00
91001	Steel Rack Accessory Bar	54.50	n/a	n/a	n/a	n/a	n/a	n/a

Product design subject to change

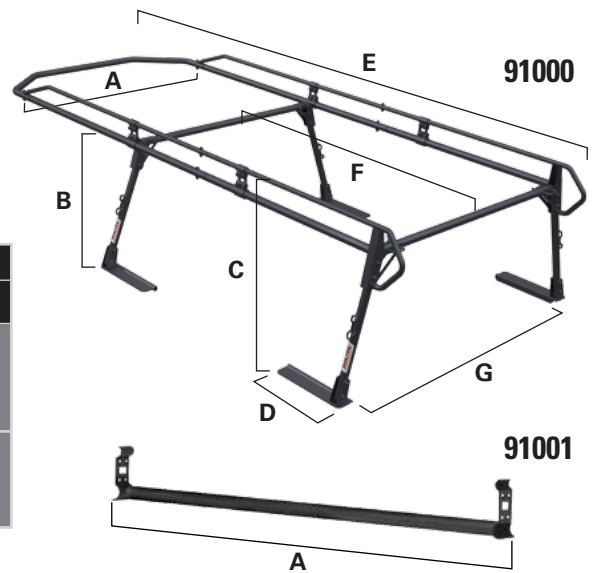

Integrated Grab Handles
– provide assistance when stepping up into truck bed

Unobstructed Loading of Tall Items with Easily Removable Rear Load Bar

Quickly Secure Load to Rack with Integrated Tie-down Cleats



Strong, Easy to Use Clamps
– provide drill-free mounting

Technical Specifications

Materials

- Core Components: High strength powder coated steel
- Hardware: Corrosion resistant coated steel

Coatings

- Core Components: Electrostatic Powder Coating

Performance Characteristics

- Load Rated for 1,000 lbs. Evenly Distributed

Physical Features

- Fully adjustable uprights accommodate various truck bed widths
- Removable rear load bar for easy loading of tall items
- Integrated tie down cleats

Utility Rac™

THE UTILITY TRUCK CARGO MANAGEMENT SYSTEM

Utility Rac™ is a sliding truck rack system designed to help you get the most carrying capacity out of your utility truck.

Aerodynamic and Quiet
– features wind deflectors to reduce noise

Internal Web Structure on Crossbar for Increased Strength

Aluminum Load Stops Adjust Across Full Width of Truck
– accommodate multi-size loads

Sliding Racks Adjust along Base Tracks to Carry Different Loads and Can Easily be Removed When Needed

Aluminum ARC Side Cleats – provide additional tie-down points

Utilizes TracRac's Modular Design Platform – increased strength and flexibility

Product Dimensions

Part Number	Description	Dimensions (inches)			
		A	B	C	D
42100-01	Utility Rac - Short	69.5	17	21.5	16
42100-02	Utility Rac - Tall	69.5	22	26.5	16
42100-03	Utility Rac - SuperDuty	69.5	28	32.5	16

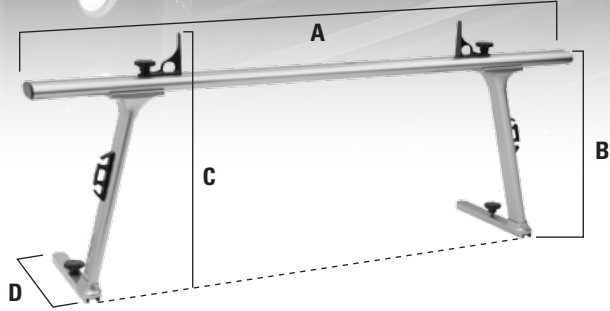

System Features

System Includes	<ul style="list-style-type: none"> • Front and Rear Powder Coated Aluminum Racks • 4 – 24" Double-T Anodized Aluminum Slide Tracks • 4 Sliding Aluminum Crossbar Load Stops • 4 Aluminum ARC Side Cleats
Load Capacity	• 1250 lbs.* <i>*When evenly distributed across both racks and installed correctly.</i>
Weight	• 55 lbs.
Finish and Material	• Durable Powder Coat Finish • 100% Rust Free Aluminum
Optional Accessory	• 4ft Extension Track: 28040

Contractor Steel Ladder Rack

THE ULTIMATE STEEL LADDER RACK

Adjustable, multi-position ladder and lumber carrying system installs easily to most pickups.

250 Pounds* of Carrying Capacity

Accommodate Various Loads with Adjustable Load Arms (22" to 37")

Maximum Corrosion Resistance – with rust-resistant e-coating

Great Looking and Long Lasting Black Powder Coat Finish

Quick and Easy Installation – limited assembly

Durable and Strong – 14-Gauge, 1 1/2" square welded steel construction

Side Rail Mount – ensures precise fit to most pickups

System Features

#14750 System Includes	<ul style="list-style-type: none">• 2 Adjustable Ladder Holders• Mounting Hardware
Load Capacity	<ul style="list-style-type: none">• 250 lbs. Load Capacity* <p><i>*When evenly distributed across both racks and installed correctly.</i></p>
Weight	<ul style="list-style-type: none">• 57 lbs.
Finish and Material	<ul style="list-style-type: none">• Durable Powder Coat Finish

CUSTOM FIT RACK SYSTEM FOR TODAY'S EURO STYLE VANS

Designed to perfectly fit each vehicle, the TracVan ES offers unsurpassed fit, function, and aesthetics. Outfit your van with this rack system and deliver a higher level of service to your customers.

Aluminum Load Stops Adjust Across Full Width of Van – accommodate multi-size loads

Aerodynamic and Quiet – features wind deflectors to reduce noise

Easy Installation Via Fixed Point Mounting



Fit List / Product Dimensions

Part Number	Make	Model	Year Span	Dimensions (inches)			
				A	B	C	D
29614	Chevrolet	City Express	'15-	53	4.75	4.00	10.25
29610	Ford	Transit	'14-	69	4.75	4.00	10.25
29611	Ford	Transit Connect	'14-	53	4.75	4.00	10.25
29612	Mercedes-Benz	Sprinter w. Fixed Points	'10-	69	4.75	4.00	10.25
29614	Nissan	NV200	'13-	53	4.75	4.00	10.25
29615	Nissan	NV1500 / 2500 / 3500	'12-	53	4.75	4.00	10.25
29613	Ram	ProMaster	'14-	69	4.75	4.00	10.25
29616	Ram	ProMaster City	'14-	69	4.75	4.00	10.25



System Features

System Includes	<ul style="list-style-type: none"> • Front and Rear Powder Coated Aluminum Load Bars • 4 Steel Reinforced Feet • 4 Sliding Aluminum Crossbar Load Stops • Custom Hardware for Attachment to Fix Points in Roof
Load Capacity	<ul style="list-style-type: none"> • 500 lbs. Load Capacity* *When evenly distributed across both racks and installed correctly. Load capacity varies by vehicle. See vehicle owners manual for specification.
Weight	<ul style="list-style-type: none"> • 30 lbs.
Finish and Material	<ul style="list-style-type: none"> • Durable Powder Coat Finish • 100% Rust Free Aluminum

TracVan®

THE ULTIMATE VAN RACK

TracVan® has the strength and functionality that you need to get the job done and the quality that will tell your customers that you care about your equipment and your work.

Aluminum Load Stops Adjust Across Full Width of Van – accommodate multi-size loads

Van Rack Shim Set
#29700 (sold separately)
Shim will compensate for curved vans

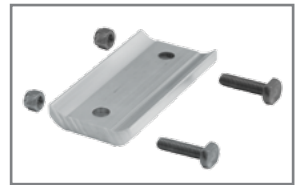

Aerodynamic and Quiet – features wind deflectors to reduce noise

Internal Web Structure on Crossbar for Increased Strength

Damage Free Installation – via rain gutter clamping solution



Product Dimensions

Part Number	Description	Dimensions (inches)			
		A	B	C	D
29055	TracVan Double	65	7.47	8.7	13.2
29056	TracVan Triple	65	7.47	8.7	13.2
29555	TracVan Single	65	7.47	8.7	13.2

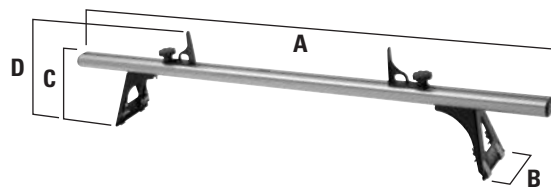

System Features

System Includes	<ul style="list-style-type: none"> • Front and Rear Powder Coated Aluminum Load Bars (Center Rack for 3 bar version) • 4 Aluminum Rain Gutter Mounts • 4 Sliding Aluminum Crossbar Load Stops
Load Capacity	<ul style="list-style-type: none"> • 500 lbs. Load Capacity* (750 lbs. Capacity for 3 bar version) *When evenly distributed across both racks and installed correctly.
Weight	<ul style="list-style-type: none"> • 35 lbs.
Finish and Material	<ul style="list-style-type: none"> • Durable Powder Coat Finish • 100% Rust Free Aluminum

CapRac™

FOR TRUCK CAPS AND SHELLS

CapRac™ is a lightweight, easy to install, aerodynamic rack will help you get the most carrying capacity out of your cap.

Aerodynamic and Quiet
– features wind deflectors to reduce noise

Aluminum Load Stops Adjust Across Full Width of Truck
– accommodate multi-size loads

Routed Entry Holes on Top and Bottom of Crossbar to Allow Easy Accessory Entry

Adapts to Curved Surfaces with Swivel Adaptor Bracket



Product Dimensions

Part Number	Description	Dimensions (inches)			
		A	B	C	D
29200	CapRac	65	5	5.5	9.94

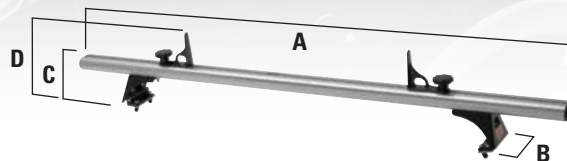

System Features

System Includes	• Two Crossbars and Mounting Hardware • 4 Sliding Aluminum Crossbar Load Stops
Load Capacity	• High Strength - Load capacity dependent on load capacity of cap/shell
Weight	• 26 lbs.
Finish and Material	• Durable Powder Coat Finish • 100% Rust Free Aluminum

Technical Specifications

Materials	– Core Components: 6063 T-6 Aluminum – Hardware: 304/18-8 SS
Coatings	– Core Components: Electrostatic Powder Coating 2.0-4.0 mils thickness tested to ASTM B117
Cross Bar T-Slot Dimensions	– Slot Opening Width: .386" – Slot Base Width: .587" – Slot Height: .275"
Physical Features	– Bullet Shaped Crossbars - Aerodynamics – Air Foil Trip Strip at Front of Crossbar – Reduces Noise – Routed Entry Holes On Top and Bottom of Crossbar to Allow Accessory Entry

Accessories

TracRac® SR Accessories



25700 Locking TracKnobs

— Designed to add security to your Sliding TracRac SR and Utility Rac Systems, the top of the knob spins freely when locked so that the over racks cannot be moved or removed.

- Includes 2 Locking TracKnobs.
- *Exclusive to TracRac® SR and Utility Rac™.



25100 Base Rail Tie-downs

— Create additional mounting points anywhere along the bed rail with the sliding powder coated aluminum tiedowns.

- Includes 2 Base Rail Tie-downs.
- *Exclusive to TracRac® SR and Utility Rac™.

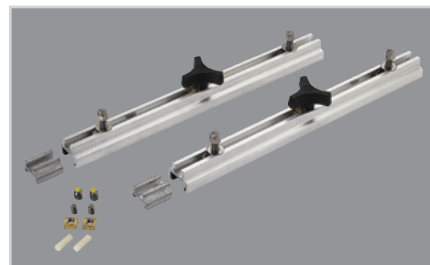

25200 TracRac Toolbox Mount Kit

— Enables user to mount, slide and reposition or remove a crossover toolbox for easy access to contents or bed space.

- *Exclusive to TracRac® SR.

Universal Accessories



24001, 24002 Cantilever Extension

— Protect your truck cab from potential damage carrying long loads, the cantilever provides 32 inches of additional coverage.

- 24001 (65" crossbar).
- 24002 (69.5" crossbar).

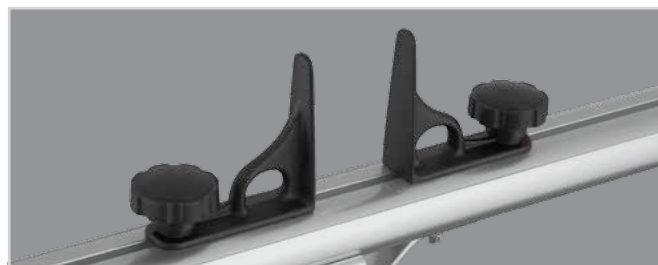

25110 Crossbar Load Stops

— Rugged aluminum Crossbar Load Stops can be adjusted along the full width of the crossbar to accommodate any size load. Built in eyelet and large knob allow user to quickly adjust, lock and secure cargo.

- Includes 2 Crossbar Load Stops.

28500 TracRac Cargo Buckle – Professional grade retractable ratchet tie-downs, the ultimate solution for securing all kinds of cargo gear and equipment to the TracRac crossbars



Accessories – FIT LIST

Part Number	Item	Fit
25100	TracRac Base Rail Tiedowns	TracRac SR and Utility Rac Base Rails Only
25700	TracRac Locking TracKnobs	TracRac SR and Utility Rac Racks Only
25200	TracRac Toolbox Mount Kit	TracRac SR and Utility Rac Base Rails Only
24001	TracRac Cantilever Extension - Compact	See Rack Fit Guide
24002	TracRac Cantilever Extension - Fullsize	See Rack Fit Guide
25110	TracRac Crossbar Load Stops (2)	All Aluminum TracRac Racks
44700	TracRac Plastic Tiedown Kit (4)	All Aluminum TracRac Racks
28500	TracRac Cargo Buckle (2)	All Aluminum TracRac Racks
41000	TracRac TracONE Toolbox Mount Kit	TracOne and T-Rac



Engineered to Deliver



Looking for dependable truck bed accessories? Rely on Thule for quality and long-lasting products.