

6395601

2009-2014

Ford SVT Raptor



6395601

2009-2014

Ford SVT Raptor

2009-2014 Ford SVT Raptor TORCH Series LED Light Kit 2 - 3" LED Cubes

TOOLS REQUIRED:

10mm Socket
13mm Socket
Ratchet and Extensions

PARTS LIST

(2) 3" LED Light Cube
(2) LED Light Cradles
(1) Left Light Mount
(1) Left Mount Support Bracket
(1) Right Light Mount
(1) Right Mount Support Bracket
(4) M6 Nylock Nuts
(4) M6 Socket Head Screw
(2) M8 Lock Nuts
(2) M8 Lock Washers
(2) M8 Bolts

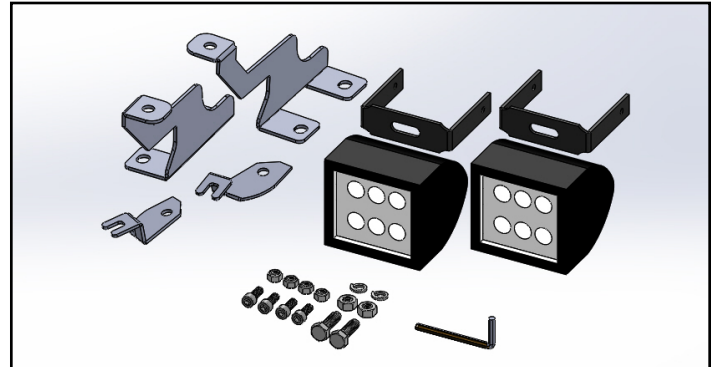

Step 1

Begin by opening the hood and removing the two rear bolts securing the hood hinge to the fender. Set aside for late use. (Fig 1)



Step 2

Position drivers side bracket underneath the hood hinge. Make sure the bracket points away from the hood and is angled towards the windshield. Reinstall the factory hinge bolts that were removed in step 1. (Fig 2)

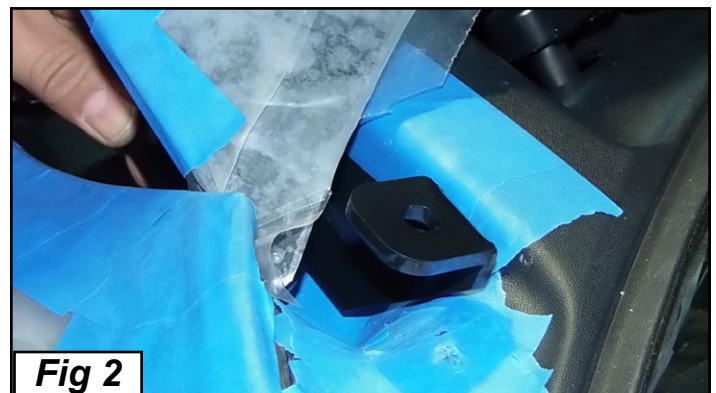

6395601

2009-2014

Ford SVT Raptor



6395601

2009-2014

Ford SVT Raptor

Step 3

Place the M8 bolts into the lower hole of the LED light cradle. Loosely secure cradle assembly with the lock washer and M8 Nuts. (Fig 3)



Fig 3

Step 4

Attach the light support bracket to the LED light cradle assembly bolt. Remove the black plastic clip on the plastic cowl. Secure the light support bracket to the cowl with the factory clip. Secure bracket to hood hinge with factory bolts. Repeat on opposite side of vehicle. (Fig 4)



Fig 4

Step 4

Wire LED Light Bar via our T-Rex optional wiring harness kit (part# 639HAR1) or custom wiring harness. T-Rex recommends Torch Lights be wired with our optional wiring harness kit (part#639HAR1). To adjust the angle of your Light Bar, rotate the Light Bar to adjust the angle, then tighten the hardware once the desired angle is achieved (please be careful not to over tighten the mounting hardware). It is best to adjust the angle with the vehicle on level ground with lights facing a wall, garage door or other solid barrier. We recommend checking from a distance of 25'. Your installation is now completed. (Fig 5)



Fig 5