

**2018 Catalog**

**sparco®**

**sparco®**

**2018  
Catalog**



# INDEX

## RACING 04 » 255



**38 » 59**

Suits



**60 » 67**

Underwear



**74 » 83**

Shoes



**90 » 97**

Gloves



**98 » 111**

Helmets



**112 » 115**

Helmets accessories



**116 » 117**

Head Restraint



**118 » 123**

Communication systems



**132 » 163**

Seats



**164 » 167**

Seats accessories



**168 » 177**

Harnesses



**178 » 187**

Steering wheels



**188 » 189**

Steering wheels accessories



**200 » 217**

Extinguishing systems

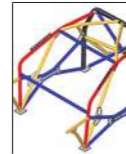

**218 » 223**

Roll cages



**224 » 233**

Technical accessories



**234 » 247**

Mechanics

## KARTING 256 » 301



**256 » 269**

Suits



**270 » 275**

Underwear



**276**

Kids articles



**277**

Articles for renting kart



**278 » 283**

Shoes



**284 » 291**

Gloves



**292 » 297**

Helmets



**298**

Steering wheels



**299**

Technical accessories



**234 » 247**

Mechanics

## PERFORMANCE 302 » 357



**302 » 313**

Seats



**314 » 319**

Harnesses



**320 » 327**

Seats for sports



**328 » 337**

Steering wheels



**338 » 341**

Gear knob



**342 » 345**

Pedal sets



**346 » 353**

Accessories

## TEAMWEAR 358 » 373

## MERCHANDISING 374 » 393

Sales conditions

**394 » 399**

## Legend symbols



Customizable



Made in Italy



Oil and fuel resistant sole



Water resistant treatment



Preformed



Impact absorber



Self-extinguishing fabric



Side fixing



Base fixing



Formula use



Rally use



GT use



Tourism use



Karting use



Off road use



Nautical use



# RACEWEAR CLOTHING

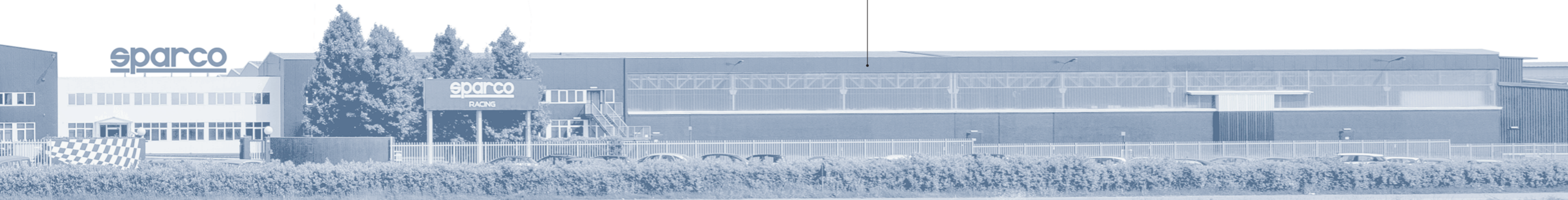
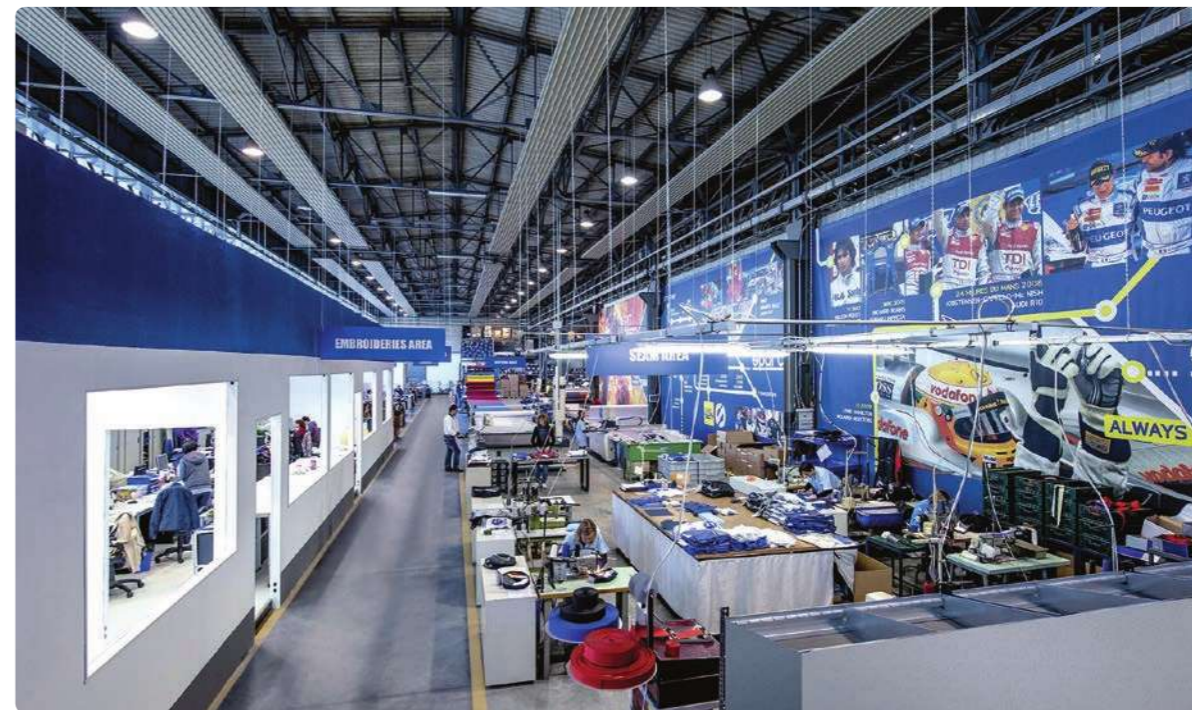

# SEATS & CARBON

OFFICIAL SUPPLIER OF YOUR PASSION



# FACTORY STORE

OFFICIAL SUPPLIER OF YOUR PASSION



# OFFICIAL SUPPLIER OF YOUR PASSION



# ON THE TRACK, ON THE ROAD

## THE FASTEST CARS IN THE WORLD ARE EQUIPPED WITH SPARCO TECHNOLOGIES



OEM SUPPLIER:



ASTON MARTIN



BENTLEY



## ENGINEERING & DESIGN

Sparco designs and engineers some of the most advanced Sport Seats in the world. The superiority of Sparco seats comes from the shells that are designed, engineered and developed with performance in mind. Our seat shells are designed using Catia 5 and NX 9 CAD software. Then the project is verified using the most sophisticated FEM & FEA structural analysis methods. Sparco knows how to design the best seat shells, whether in prepreg carbon, forged carbon or glass fiber. But the shape is just as important in a sport seat. Supercar drivers want seats that allow them to "feel" the performance, the handling and the behavior of the car while racing or fast driving. Therefore, our sport seats are designed like customized suits that fit each driver at best. But the demanding Supercar customers also want the best possible comfort, for long distance, and for as smooth as possible driving experience. This is why ergonomic studies are so important for the engineers who design Sparco seats. A good trim and foam design is the foundation for high speed performance as much as a light and rigid shell. Together they form the winning combination of the Sparco sport seat for Supercars.



## SEATS



Sparco started manufacturing Sport Seats in OEM in 1998 for the Lamborghini Diablo. Sparco studied, designed and developed the first adjustable sport seat in Carbon Fiber for Supercars, satisfying the safety & durability requirements of the most demanding car makers. Since those days, Sparco supplied sport seats to Lamborghini, Ferrari, Bugatti, Aston Martin, Bentley, Audi, McLaren Cars, AMG Mercedes Benz, Alfa Romeo, Lotus Cars, Koenig-gsegg, Maserati, Ford GT, Mini John Cooper Works and many more sport and supercar makers. Sparco seats for Supercars have the same DNA, the same engineering and capability of the Sparco racing seats. They are light, thin yet safe and comfortable. Furthermore, Sparco Sport Seats for Supercars are often luxuriously trimmed in sporty Alcantara or in the most exclusive and expensive leathers. Since 2010, Sparco offers Sport seats for Supercars with Side Bag, up to 12 way Power assisted adjustments, Heating and Cooling systems and comfort features like Lumbar Adjusters. And, as the technological innovation never stops, Sparco has gained the leadership by being the first to offer short fiber technology for the most complex yet lightest sport seats. Today, Sparco is the only manufacturer that offers seats with side airbags wrapped by a real carbon fiber cover, granting an uninterrupted look and the highest safety standards.

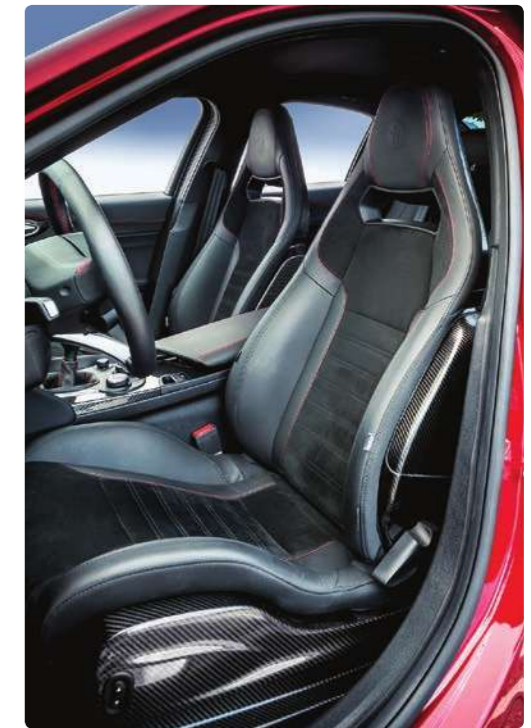



## QUALITY

The Quality on Sparco sport seats is not only the “cherry on top” of the production process, but is a mindset that starts from the design of the seat and goes through the various manufacturing processes until the end of line product checks. Seats and carbon parts are designed according to DFMEA and PFMEA methodology, that allow to detect potential mistakes in design and process before they happen. Then, the test for qualification and product approval are carried out according to the demanding PPAP procedures used by the world class car industry. Sparco applies the ISO/TS:16949 Quality System in all the steps of the seat and carbon fiber design, development and manufacturing. On top of this method, each of the supercar makers has its own requirements, that our quality team implements and matches with our processes. Only the best, for the most sophisticated cars of the planet.



## CARBON TECHNOLOGY

Carbon Fibre is the most advanced material used in the automotive industry. Incredibly light and strong, Carbon Fibre was created as an aerospace and military material and introduced in F1 by the ingenious founder of Lotus, Colin Chapman, in 1981 on the Lotus 88 F1 car. Sparco started using carbon fibre for its racing seats in 1984 and since then never stopped designing the most technically advanced racing seats. In 1999 Sparco created a dedicated carbon fibre and sport seats division, devoted to supplying the Supercar and aerospace industry. Today, 9 autoclaves (2 autoclaves have been added in 2014) and over 250 employees are working to create carbon parts for supercars like the Lamborghini Aventador, the Alfa Romeo Giulia QV as well as parts for superjets like the Airbus A380. Carbon Fibre is not an easy material to deal with. It has a complicated, non-linear stress behavior and requires a sophisticated design and engineering approach to generate the light and strong parts used in extreme applications like racing cars, supercars and planes. In 2014 Sparco has added the pressed carbon fiber technology. This new technology reduces the production time, increasing Sparco's production capacity while maintaining the excellent performance of the carbon fibre materials.





# A SUIT TAILORED FOR YOU

## 5 simple rules to follow to complete your custom suit

# 1

### MODEL

Draw your suit. Send it to our sales customer office or to your nearest Sparco dealer, or simply choose from different Sparco models. Our production department will check the feasibility of the project before it is accepted.



# 2

### IDENTIFY YOUR SIZE

You can easily identify your size by using the size chart here below. If you cannot find the correct standard size, you can create a made-to-measure suit by following the instructions in the chart beside. However we do suggest that you go to the nearest Sparco dealer who will assist you in the task.

# STANDARD SIZE CHARTS

# MADE-TO-MEASURE CHART

SUITS - KID BODY SIZE CHART / TABELLA MISURE FISICHE PER BAMBINO														
KID	CHEST CIRCUMFER.	WAIST CIRCUMFER.	PELVIS CIRCUMFER.	THIGH CIRCUMFER.	SHOULDER WIDTH	SLEEVE LENGHT	FRONTAL CHEST LENGHT	EXTERNAL LEG LENGHT	INSEAM LEG LENGHT	BACK LENGHT	NECK CIRCUMFER.	cavallo	HEIGHT	WEIGHT
	cm	cm	cm	cm	cm	cm	cm	cm	cm	cm	cm	cm	cm	kg
età / taglia	A	B	C	D	E	F	G	H	L	M	N	P		
6-7 / 120	60-63	55-60	69-71	37-39	28-30	44-47	41-44	67-71	52-54	29-31	32-34	104-106	116-125	20-23
8-9 / 130	64-67	61-63	72-75	40-42	31-33	48-51	45-48	75-79	57-60	32-34	34-36	107-110	126-135	24-28
10-11 / 140	68-71	64-67	76-79	43-44	34-36	52-55	49-52	83-87	63-66	35-37	37-39	111-113	136-145	29-36
12-13 / 150	72-75	68-71	80-83	45-47	37-39	56-59	53-56	91-95	69-72	38-41	40-42	114-117	146-155	37-44

SUITS - MAN BODY SIZE CHART / TABELLA MISURE FISICHE PER ADULTO														
MAN	CHEST CIRCUMFERENCE	WAIST CIRCUMFERENCE	PELVIS CIRCUMFERENCE	THIGH CIRCUMFERENCE	SHOULDER WIDTH	SLEEVE LENGHT	FRONTAL CHEST LENGHT	EXTERNAL LEG LENGHT	INSEAM LEG LENGHT	BACK LENGHT	NECK CIRCUMFERENCE	HEIGHT	WEIGHT	
	cm	cm	cm	cm	cm	cm	cm	cm	cm	cm	cm	cm	kg	
size / taglia	A	B	C	D	E	F	G	H	L	M	N			
XS	44	86-89	74-77	86-89	45-48	37-40	54-57	62-64	97-100	72-74	41-43	37-38	164-167	54
	46	90-93	78-81	90-93	47-50	39-42	56-59	64-66	98-101	73-75	42-43	38-39	167-170	60
S	48	94-97	82-85	94-97	49-52	41-44	58-61	66-68	99-102	74-76	42-44	39-40	170-173	66
	50	98-101	86-87	98-101	51-54	42-46	60-63	68-70	100-103	75-77	43-44	40-41	173-176	72
M	52	102-105	88-93	102-105	54-57	45-48	62-65	70-72	101-104	76-78	44-45	41-42	176-179	78
	54	106-109	94-97	106-109	56-59	47-50	64-67	72-74	102-105	77-79	45-46	42-43	179-182	84
L	56	110-113	98-101	110-113	59-62	49-52	66-69	74-76	103-106	78-80	46-48	43-44	182-185	90
	58	114-117	102-105	114-117	61-64	51-54	68-71	76-78	103-107	79-81	48-49	45-46	185-188	96
XL	60	118-121	106-109	118-121	64-67	53-56	70-73	78-80	105-108	80-82	49-51	46-47	188-191	102
	62	122-125	110-113	122-125	67-70	56-58	72-75	80-82	107-110	81-83	51-52	47-48	191-194	108
XXL	64	126-129	114-117	126-129	69-72	57-60	74-77	82-84	108-111	82-84	52-54	49-50	194-197	114
	66	130-133	118-121	130-133	72-75	59-62	76-79	84-86	109-112	83-85	53-55	51-52	197-200	120

NB: If Your measurements differ from standard size, please verify with a tailor measuring tape and complete the Driver's chart measurements; It's recommended also complete the optional measures. Please note that these physical measurements charts are indicative only for commercial purposes, then are only usefull for Sparco products. Note only for the kids' product sizes: Take into account any uses of chest protectors and its related footprint.

GLOVES										
Hand (inches)	3-4½	4-5½	5-6½	6-7½	7-8½	8-9½	9-10½	10-11½	11-12½	
Hand (cm)	7½-10½	10-14	12½-16½	16½-19	18-21½	20-24	23-26½	25½-29	28-32	
Letter sizes	XXXXXS	XXXS	XXS	XS	S	M	L	XL	XXL	
Number sizes	5	6	7	8	9	10	11	12	13	

To determine your size, it is recommended to measure the dominant hand (e.g. the right hand if you are right handed) as this will typically be larger. Measure around the largest part of the hand over knuckles while making a fist, excluding thumb.

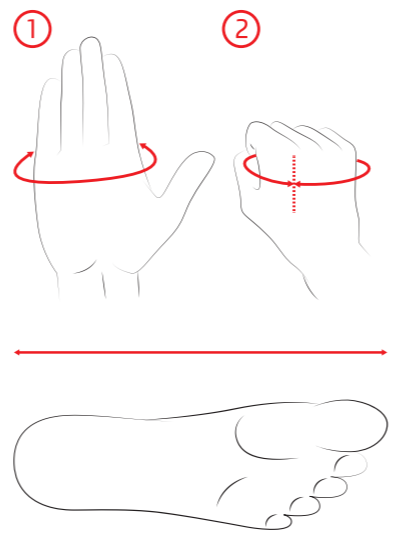

SHOES														
UK	3½	4	5	5½	6½	7	8	9	9½	10½	11	12	13	14
US	4½	5	6	6½	7½	8	9	10	10½	11½	12	13	14	15
Continental	36	37	38	39	40	41	42	43	44	45	46	47	48	49
Japanese (cm)	23	23½	24	24½	25	26	27	28	28½	29½	30	31	32	33

**A THORAX CIRCUMFERENCE**

cm:

Use a tape measure, run under armpit, put in the largest part of the chest in horizontal position, arms at your sides.

**B WAIST CIRCUMFERENCE**

cm:

Run tape measure around waist horizontally, arms at your sides.

**C PELVIS CIRCUMFERENCE**

cm:

Run tape measure around basin in the largest point, arms at your sides. Put the tape measure 18-20 cm under waist point.

**D THIGH CIRCUMFERENCE**

cm:

Run tape measure around the thigh horizontally, try to measure the largest part of the thigh. You should be around 10 cm from the crotch.

**E SHOULDER WIDTH**

cm:

Arms at your sides, run tape measure from bone to bone. It is important that the tape is rigid in order to obtain a proper measure.

**F SLEEVE LENGTH**

cm:

Start the measurement from shoulder bone, running the tape measure around elbow (arm slightly flexed) until wrist bone.

**G FRONTAL CHEST LENGTH**

cm:

Take the measure starting from the notch of the neck to the front of crotch (reference stitch of the underwear). It is important to put the tape measure in the correct position, always keeping in tension in a vertical position.

**H EXTERNAL LEG LENGHT**

cm:

Put tape measure laterally, and run the tape measure from waist to ankle bone.

**L INTERNAL LEG**

cm:

Run tape from crotch to internal ankle bone.

**M REAR LENGHT**

cm:

Run the tape measure from lower vertebra of the neck to the waist (see point 2).

**N NECK CIRCUMFERENCE**

cm:

Run your tape measure around the neck and close the circle. Please indicate in the space below the value in centimeters.

**O BICEPS CIRCUMFERENCE**

cm:

Run the tape measure around the widest point of the biceps. Close the circle with the tape measure and indicate in the space below the value in centimeters.

**P TOTAL CROTCH LENGHT**

cm:

Take the measuring tape and put it in front of your body. The measurement should be taken starting from the notch of the neck to the lower vertebra of the neck, passing by the horse. The tape should then have a complete round from the front to the back.

### PRIME SP-16 / PRIME SP-16+

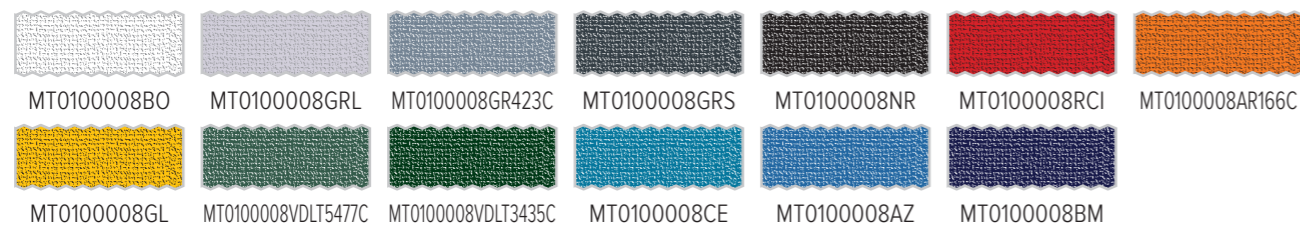

### NEW | EAGLE RS-8.2

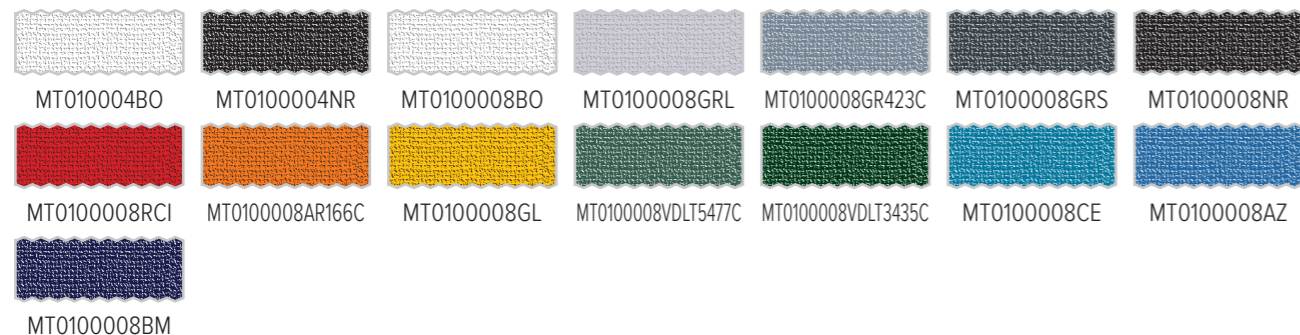

### NEW | SUPERSPEED RS-9

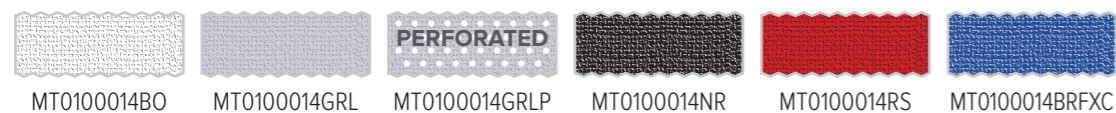

### NEW | VICTORY RS-7

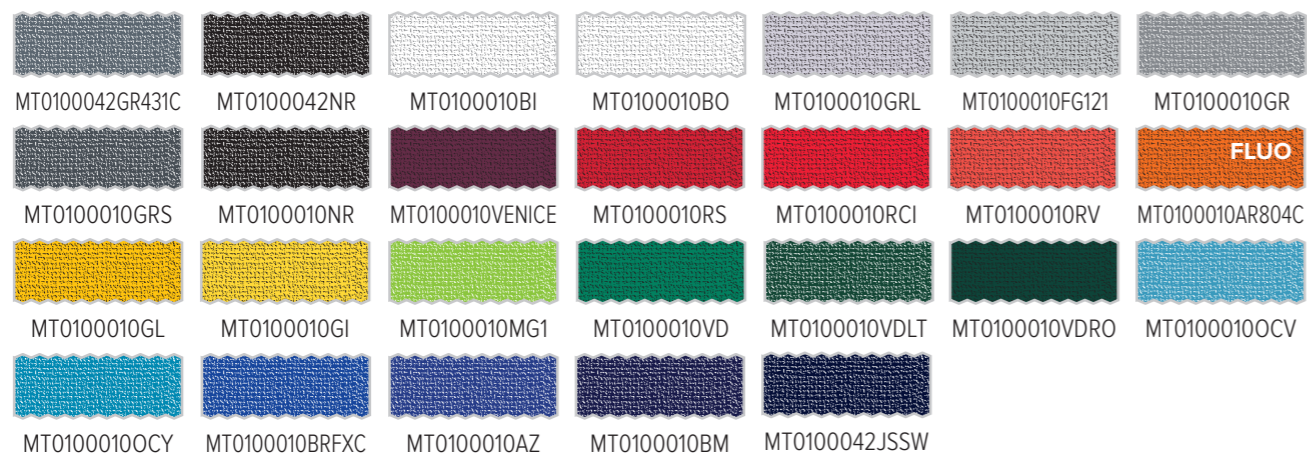

**3 COLOURS AND FABRIC**  
Select your required colours and fabric from the wide Sparco range. Colours availability as shown in the colour chart.

**4 DESIGN**  
Customize the suit by adding stripes, squares and coloured stitching.

### ENERGY RS-5



### NEW | GRIP RS-4

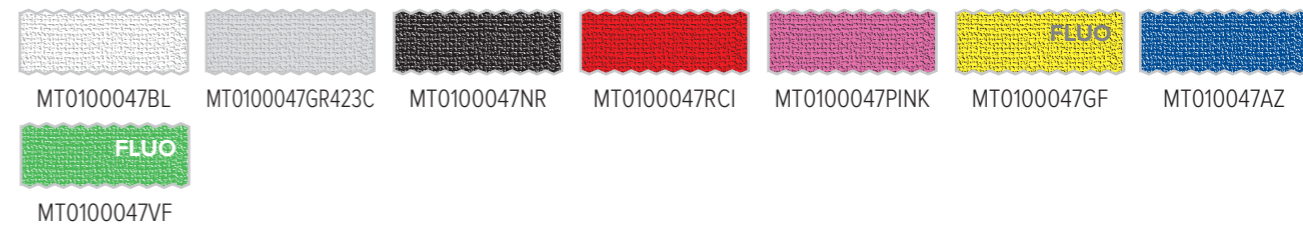

### SPRINT RS-2.1

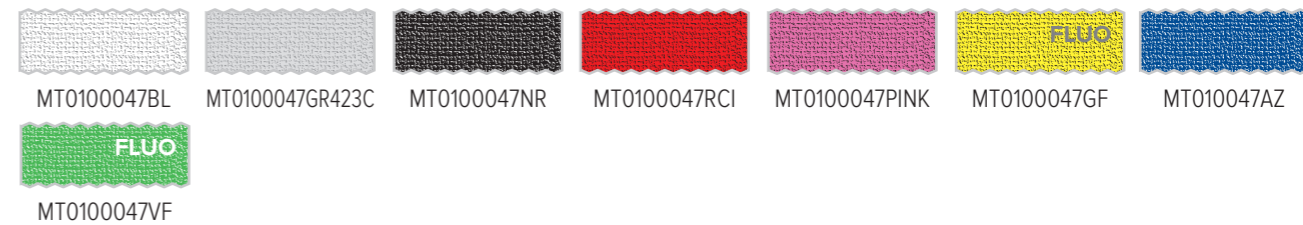

**5 EMBROIDERIES**  
It is possible to embroider writing and logos on to the suit. Important: Do not forget to attach the computer tape of the embroidery or the logo images in .jpg format in high resolution.

## SPARCO CONFIGURATORS

### DO YOU HAVE A UNIQUE AND ORIGINAL PRODUCT IN MIND?

Are you dreaming of a suit, gloves, shoes or even seats created by you? Do you really want to Be Sparco - Be Original? Now you can. With the new online configurator, Sparco is the only company on the market able to offer, 2/7, an efficient service for custom gloves, shoes, suits and seats. What are you waiting for? Go to the Sparco website. Customise online, customise with Sparco!



# SPARCO INFINITY



**FIA APPROVED**  
 MANUFACTURER: SPARCO  
 MODEL: R538  
 HOM. NO: RS 245.13  
 FIA STANDARD: 8856-2000

Enter the new Sparco Infinity world.  
 The first fireproof overalls in the world fully customizable.  
**Over 64.000 colours at your disposal**  
 Your Creativity, our Technology.  
 Your Idea, our Expertis.  
 Make your overalls unique with Sparco Infinity.



Infinity 2.0 | 0011027SP |

## RACING INFINITY 2.0 & KARTING PRIME KS-10







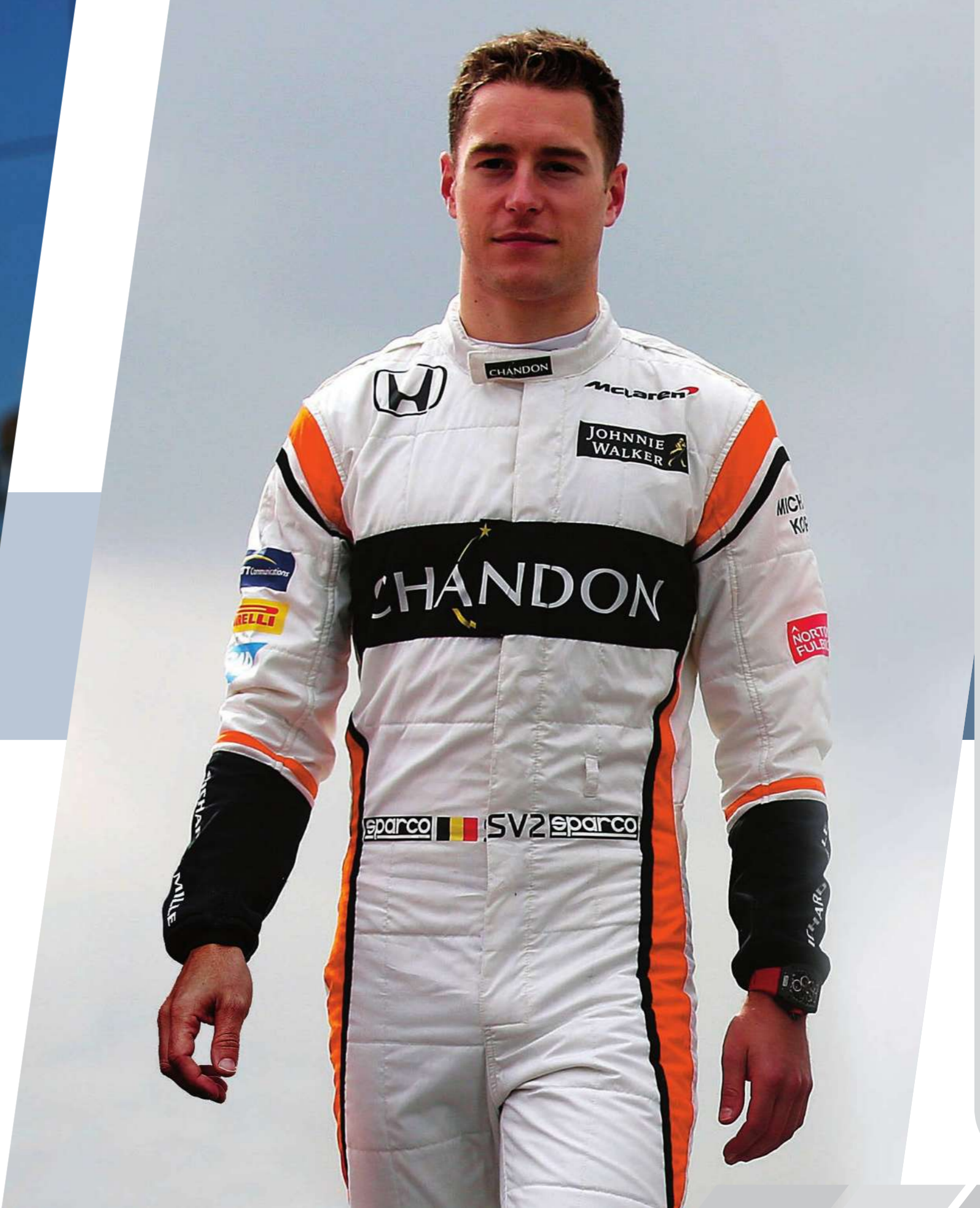
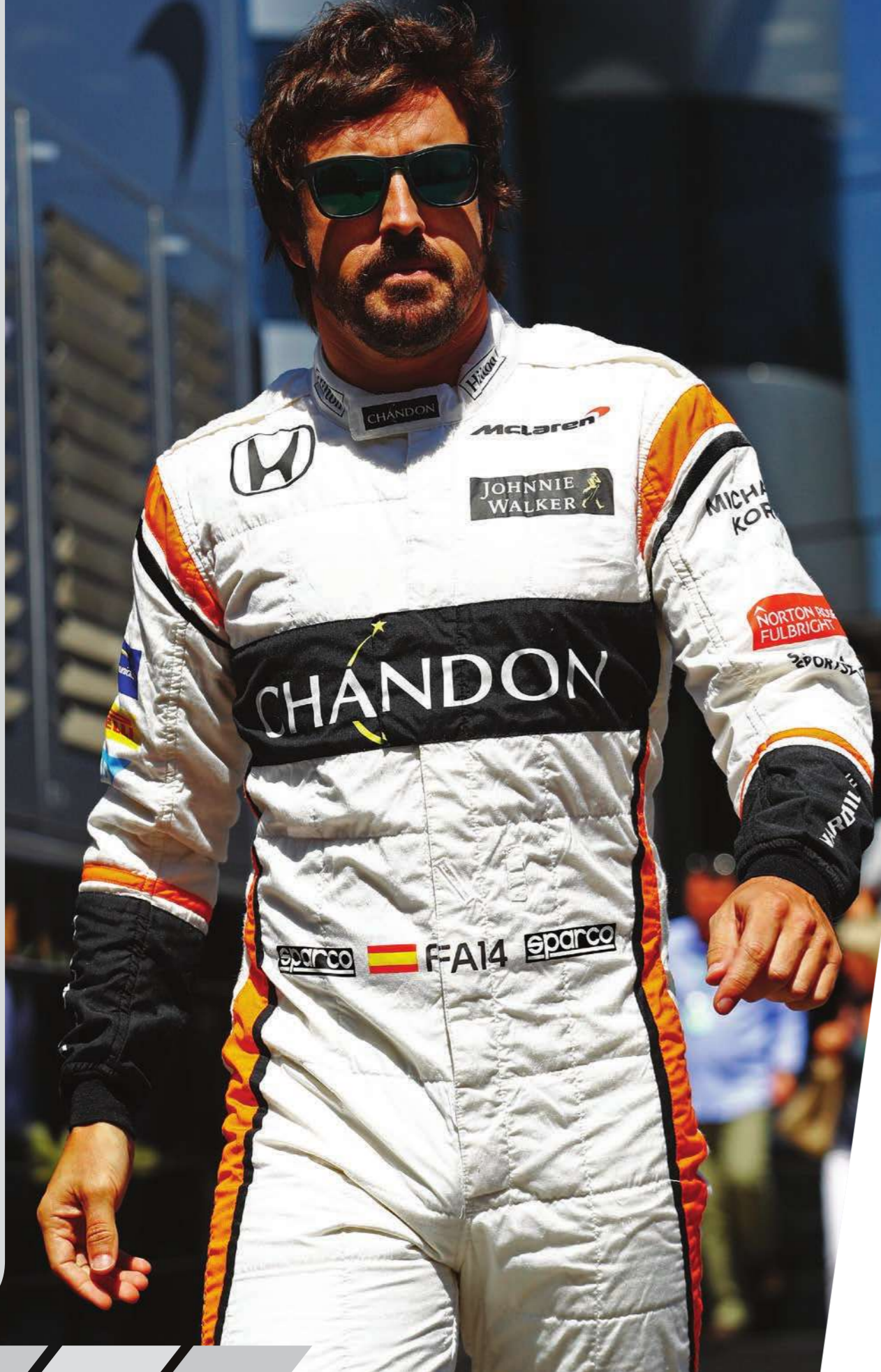





OFFICIAL SUPPLIER OF YOUR PASSION



sparco®

OFFICIAL SUPPLIER OF YOUR PASSION

OFFICIAL SUPPLIER OF YOUR PASSION

OFFICIAL SUPPLIER OF YOUR PASSION

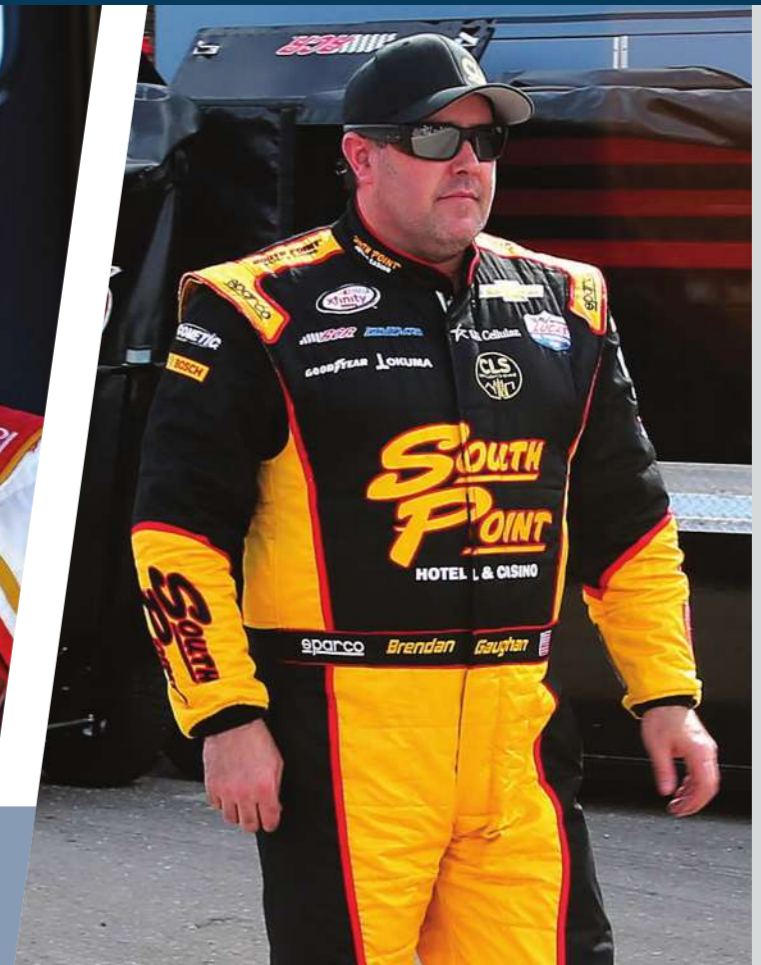
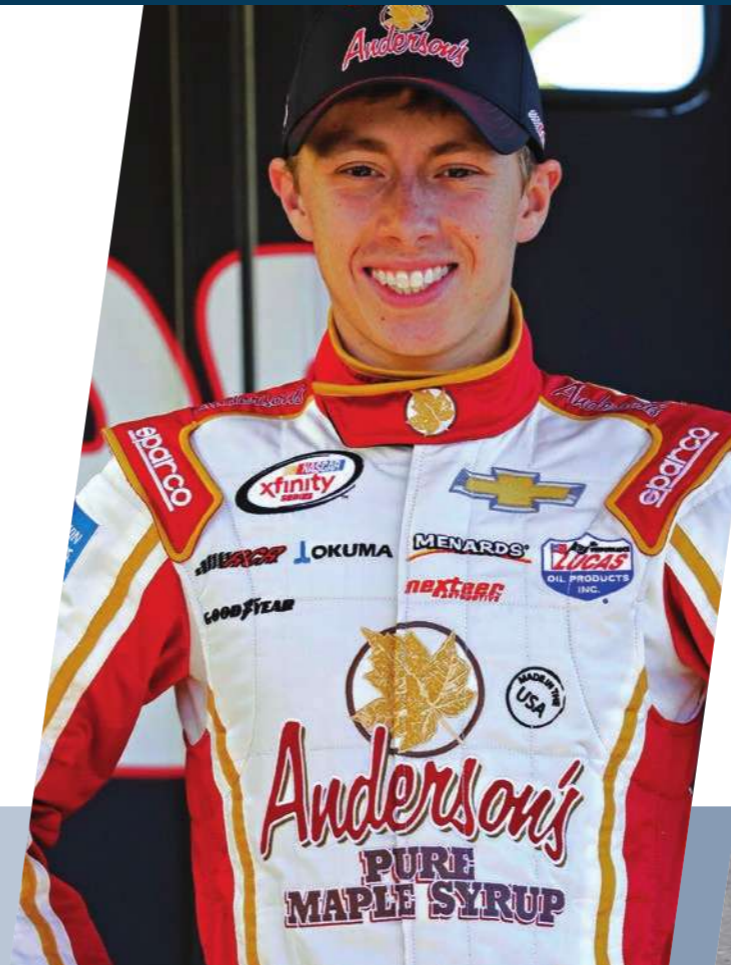
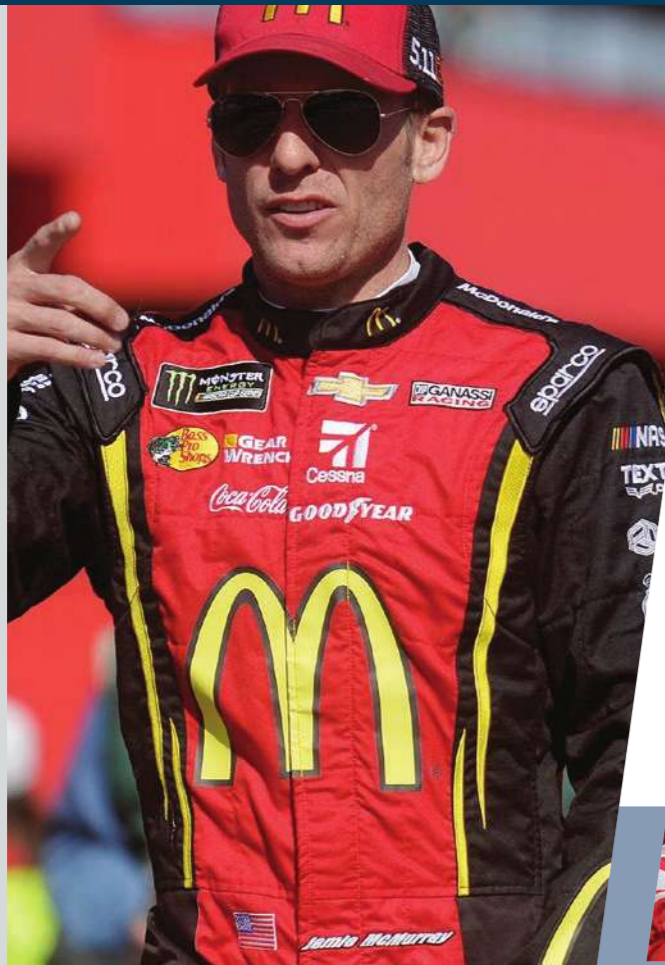

OFFICIAL SUPPLIER OF YOUR PASSION

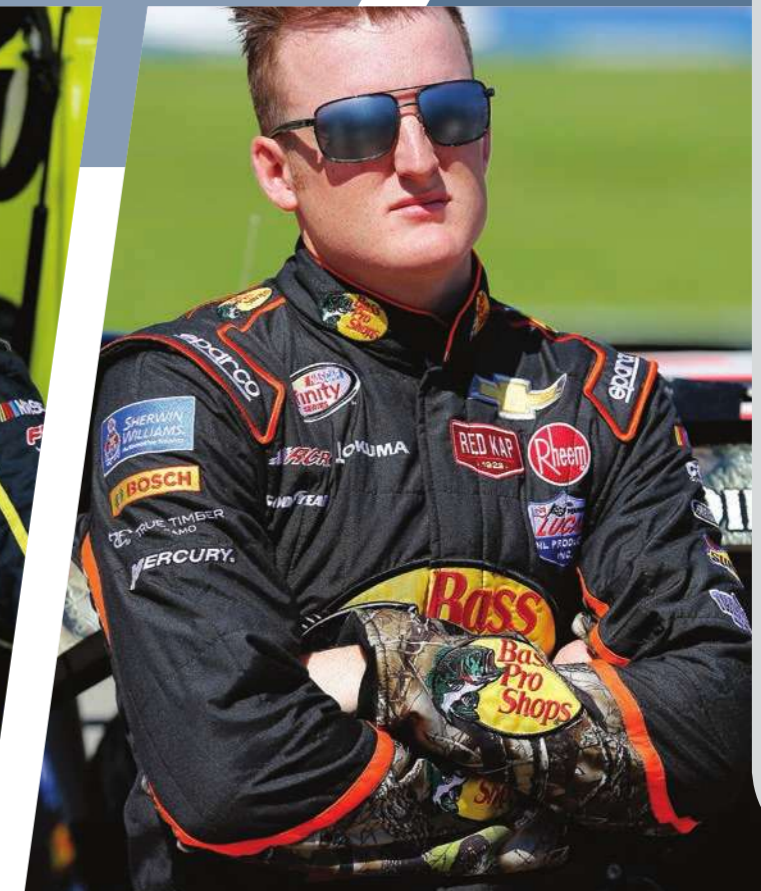

# RACING SUITS



# PRIME SP-16+

FIA 8856-2000	0011321SP	
NOMEX®		Size: 48-66
240/270 g/m <sup>2</sup>	3 Layers	

(ON DEMAND)

The Prime SP-16+ is made in collaboration with the McLaren Honda F1 Team and is the lightest ever FIA approved racing suit. The Prime Sp-16+ has unparalleled technological features: created in the Sparco R&D laboratories, it weighs only 590 gram (size 52) and is unbelievably comfortable. The Prime SP-16+ has just 2 layers which makes it highly breathable. The project involved optimising every single detail including the ultra slim zip, seamless Nomex/Viscosa wrists and ankles, reduced neck and shoulder pads, thinner thread and more flattened stitching. The Prime SP-16+ is a suit uniquely designed to withstand extreme use and maximize performance.



**FIA APPROVED**  
 MANUFACTURER: SPARCO  
 MODEL: R547-PRIME SP16-SPEC2  
 HOM. NO: RS.282.16  
 FIA STANDARD: 8856-2000

## PRIME SP-16



## PRIME SP-16

FIA 8856-2000		
NOMEX®		Size: 48-66
240/270 g/m <sup>2</sup>	3 Layers	

The Prime SP-16 suit was designed to provide drivers light weight material, comfort and breathability. Even the smallest details in terms of materials, construction and accessories were taken to the limits to ensure weight optimization down to the very last gram.

**COMPOSITION:** Meta-aramid/polyamide-imide.

Three-layer sandwich weighing less than 240/270 g/m<sup>2</sup>.

**CHARACTERISTICS:** The three-layer Prime SP-16 suit features elasticised panels at the armpits and back made from a light, breathable fabric. The third outer layer is a double face mesh made from original DuPont Nomex® Comfort woven using the Kompact system. This material contains a high percentage of antistatic fibres which provide extremely effective antistatic properties. The Prime SP-16 suit is FIA approved and has all the latest

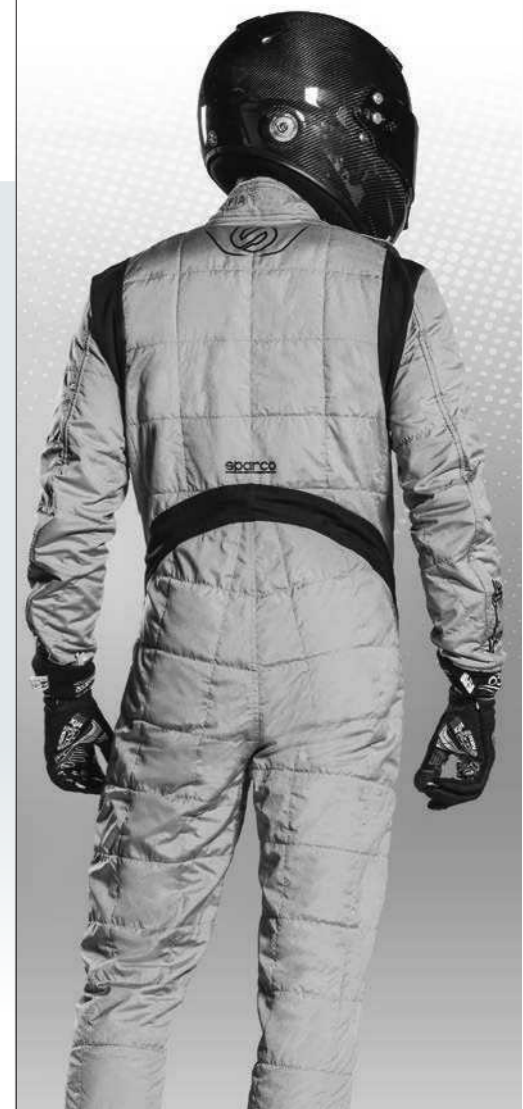

001132..GR

001132..NR



# EAGLE RS-8.2



## NEW EAGLE RS-8.2

FIA 8856-2000		
HOCOTEX	NOMEX®	Size: 48-66
290/320 g/m <sup>2</sup>	1 Layer	

**COMPOSITION:** NOMEX® antistatic HOCOTEX™ fabric. Single layer sandwich with an average weight of 290/320 g/m<sup>2</sup>.  
**CHARACTERISTICS:** The single layer Eagle RS-8.2 suit is made from a breathable, ultra-thin, multi-layer fabric (0.6 mm). It is made by pairing Hocotex fabric with other support fabrics including Eagle fabric for the panels at the back, sides and armpits. The Eagle fabric is a tried and tested material with better breathing and resistance properties than traditional jersey. Ultra-thin stitched quilting is used in classic style reinforced with anti-abrasion material on the legs and arms. The suit includes integrated extraction apauettes. The shoulders, which are compatible with the use of Hans devices, were designed to reduce pressure during races.  
**PERSONALISATION:** fireproof transfer printing (recommended) - embroidery.



PREZZI IVA ESCLUSA • VAT NOT INCLUDED • PRECIOS SIN IVA

0011278H..BNRS

0011278H..BNAZ

0011278H..NGRS

0011278H..NGGR





VICTORY RS-7



**NEW**  
**VICTORY RS-7**

FIA 8856-2000	SFI 3.2A/5	
	Meta Aramid	Size: 48-66
330/360 g/m <sup>2</sup>	1 Layer	

**COMPOSITION:** Meta-Aramid HOCOTEX™ fabric, Single layer sandwich with an average weight of 330/360 gr/m<sup>2</sup>.  
**CHARACTERISTICS:** The suit was designed with the aim of ensuring maximum driver comfort while driving, with elasticised panels made of double-fronted soft mesh (armholes and back) and preformed sleeves. The suit is equipped with contrasting panels in flat ultralight cloth and new Sparco personalised linings, with some details in partial view, producing the characteristic Sparco style. Stitched quilting with ultra-thin yarn evokes the classic Sparco style, the suit has integrated extraction epaulettes made in the typical Sparco shoulder design, concealed pockets, preformed neck and belt with the characteristic Sparco logo.  
**PERSONALISATION:** fireproof transfer printing (recommended) - embroidery.



PREZZI IVA ESCLUSA • VAT NOT INCLUDED • PRECIOS SIN IVA

0011277H..GRAR

0011277H.. GRAZ

0011277H.. NRGR

0011277H.. NRRS



# VINTAGE CLASSIC (ON DEMAND)

FIA 8856-2000		
300 g/m <sup>2</sup>	3 Layers	Size: 48-66



MANUFACTURER: SPARCO  
MODEL: R511  
HOM. NO: RS.049.03  
FIA STANDARD: 8856-2000

Lightweight suit based on the 70's retro apparel.  
COMPOSITION: 3 layers suit: 300 g/m<sup>2</sup>  
FEATURES: Inner lining highly breathable and antistatic.  
Zip pocket on chest.



001103..CE

001103..EC



## SUPERSPEED RS-9

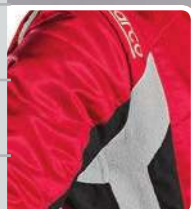

## NEW SUPERSPEED RS-9

FIA 8856-2000	SFI 3.2A/5	
Meta Aramid		Size: 48-66
290/320 g/m <sup>2</sup>	3 Layers	

**COMPOSITION:** Double-faced silk/aramid multilayer fabric. Three-layer sandwich with an average weight of 290/320 gr/m<sup>2</sup>.

**CHARACTERISTICS:** Made of a medium-light slim compound, but notably with a new outer fabric partly made of high-range natural fibres such as silk. The fabric is also used in a mesh version for better breathability. The suit has elastic panels made of Eagle fabric (complete armholes, sides, kneecap leg panels and back) and preformed sleeves. The suit is equipped with contrasting panels in flat ultralight cloth. Stitched quilting with thin yarn evokes the classic Sparco style. The suit includes integrated extraction epaulettes attached to the armholes, concealed pockets, preformed neck, and belt with the characteristic Sparco logo.

**PERSONALISATION:** fireproof transfer printing (recommended) - embroidery.



MANUFACTURER: SPARCO  
MODEL: XX  
HOM. NO: XX  
FIA STANDARD: 8856-2000



0011279.. RS

0011279.. AZ

0011279.. BI

0011279.. NR



ENERGY RS-5



ENERGY RS-5

FIA 8856-2000	SFI 3.2A/5	
Meta Aramid		Size: 48-66
330/360 g/m <sup>2</sup>	3 Layers	

Evolved version of the Lunargrid RS-6 which has been simplified and optimised to be easily personalised. This suit has three ultra-thin, breathable layers with a panel in a third color.

**COMPOSITION:** Meta Aramid. Three-layer sandwich with an average weight of 330/360 g/m<sup>2</sup>.

**CHARACTERISTICS:** The three-layer Energy suit is made from fabrics which offer an excellent compromise between weight and breathability. Elasticised armpits and back panel for increased driver comfort. Zip pull at neck and waist. Jean type pockets, preformed sleeves and lightened fabric with the same materials as used for all the top/medium range suits.

**APPROVED**  
 MANUFACTURER: SPARCO  
 MODEL: R549-ENERGY RS-5  
 HOM. NO: RS.295.16  
 FIA STANDARD: 8856-2000



0011273..RSSI

0011273..AZNR

0011273..GRSI

0011273..NRSI



GRIP RS-4



**NEW**  
**GRIP RS-4**

FIA 8856-2000	SFI 3.2A/5	
Meta Aramid		Size: 48-66
360/390 g/m <sup>2</sup>	3 Layers	

**COMPOSITION:** Meta-Aramid, three-layer sandwich.  
**CHARACTERISTICS:** Made with a new compound and new-generation raw materials giving it an excellent value for its cost. This suit, conceived for maximum driver mobility and comfort during driving, is made with the traditional double-fronted jersey mesh front, uncovered, for reducing thickness and weight; a large back panel, made of the same material, gives the garment an unequalled degree of driving-seat comfort; preformed sleeves and NASCAR style pant legs. Stitched quilting with ultra-thin yarn, integrated extraction epaulettes made in the classic Sparco shoulder design, concealed pockets, preformed neck and belt. **PERSONALISATION:** fireproof transfer printing - embroidery.



PREZZI IVA ESCLUSA • VAT NOT INCLUDED • PRECIOS SIN IVA

0011275.. NGRG

0011275..ANRG

0011275.. BNRR

0011275.. NRGR





## SPRINT RS-2.1

FIA 8856-2000	SFI 3.2A/5	CE
Meta Aramid		Size: 48-66
360/390 g/m <sup>2</sup>	2 Layers	

The Sprint RS-2.1 is an excellent entry level suit. Improved details and top quality materials. The suit can be easily personalised including the use of prints and features mesh panels at the armpits and back.

**COMPOSITION:** Meta Aramid.

Two-layer sandwich with an average weight of 360/390 g/m<sup>2</sup>.

**CHARACTERISTICS:** The Sprint RS-2.1 suit has two layers made of new generation fabric and offers excellent value for its cost. Suit includes elastic armpits and back panel for increased driver comfort. Jean type pockets, preformed sleeves and light fabric which has the same materials as used for all the top/medium range suits.



MANUFACTURER: SPARCO  
MODEL: R548-SPRINT RS-2.1  
HOM. NO: RS.287.16  
FIA STANDARD: 8856-2000



001091..NRBI

001091..NRRS

001091..RS

001091..AZ

001091..NR



# ONE RS-1

SFI 3.2A/1		
180 g/m <sup>2</sup>	1 Layer	Size: S-XXL



001052NR..

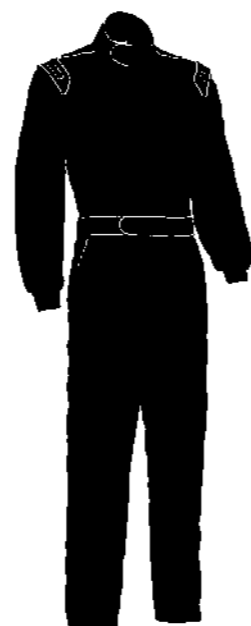

One layer suit. **COMPOSITION:** One layer fabric: 180 g/m<sup>2</sup>  
**FEATURES:** Suitable for national or historic race drivers, mechanics, race officials and technicians.



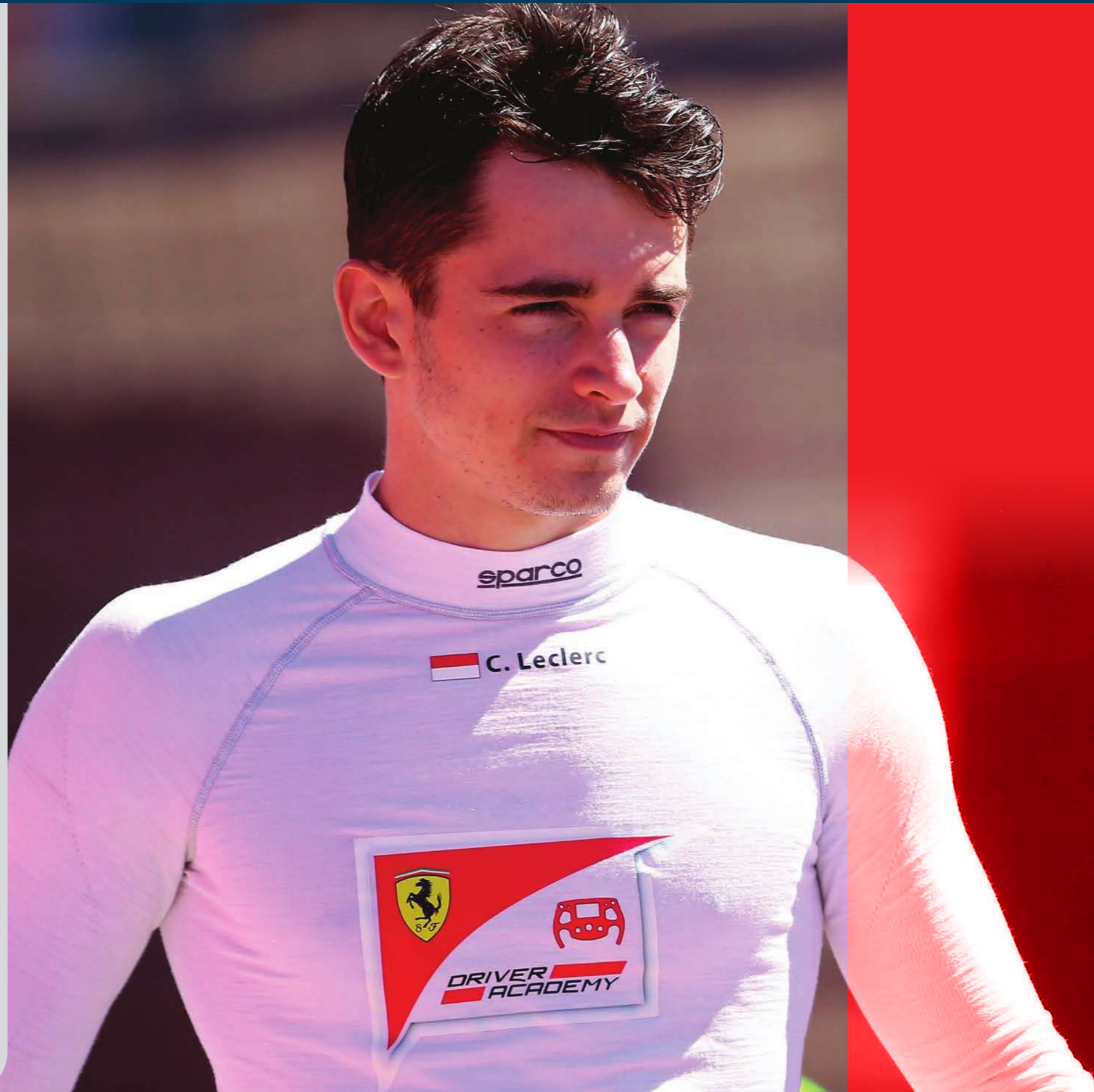

# RACING UNDER WEAR



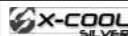

# SHIELD RW-9



FIA 8856-2000	SFI 3.3	
		

Revolutionary Underwear designed to conform to body shape with technical material (Aramid Jersey, Acrilate, Modal Viscose, Elastane) in order to obtain incredible comfort while driving. New fiber has been designed and constructed to remove sweat as quickly as possible, for added breathability and freshness. Shield RW-9 is seamless with added breathability to the back, armpit, and chest areas. SPARCO underwear weighs only 180 g/m<sup>2</sup>, most lightweight fireproof underwear in the world. Shield RW-9 also contains X-Cool fibers which guarantee comfort and freshness.





SIZE	COL	CODE
XS/S - M/L - XL/XXL - XXXL		001764MBO..
		001764MNR..





SIZE	COL	CODE	
XS/S - M/L - XL/XXL - XXXL		001765PBO..	90,00
		001765PNR..	





SIZE	COL	CODE
38/39-46		001510ICE..
		001510ICENR..



SIZE	COL	CODE
XS/S - M/L - XL/XXL - XXXL		001795BO..
		001795NR..



SIZE	COL	CODE
XS/S - M/L - XL/XXL - XXXL		001795BO..
		001795NR..





Cuciture extra piatte. Extra flat seams.  
Costuras extra planas.



SIZE	COL	CODE
XS/XL - XL/XXL		001494BO..
		001494NR..



SIZE	COL	CODE
38/39 - 40/41 - 42/43 - 44/45 - 46		
		001512BI..
		001512NR..

## COMPRESSION

**COMPOSITION:** 10%Meta-aramid. 84% Viscose. 6%Elastan.

**CHARACTERISTICS:** Derived from the new graduated compression socks commonly used for sports, these use the same principles as compression therapy with a particular characteristic: exerting maximum pressure at the ankle that decreases as it goes up the leg facilitating bloodflow upwards. Sparco COMPRESSION socks have a class 1 (> 21 mmHg) compression force and are effective in preventing the development of circulatory problems and extremely effective in alleviating the feeling of heaviness and fatigue in the legs.



Simply add to your washing machine before washing overalls or underwear and the original X-Cool treatment is recharged. Treats one racesuit or 1 set of underwear (pant, top and socks).

# DELTA RW-6

FIA 8856-2000

The new Delta RW-6 fabric is made from a mixture of very comfortable, soft fibres by means of a processing method known as "body-size" in which the garment is produced as a single piece item with no stitching at the sides. This type of process means different sections can be made more or less elastic to meet differing needs. The existence of more elastic sections makes the garment more comfortable to wear.

#### COMPOSITION:

50% Flame Retardant Cotton - 50% Modacrylic Fibres.  
Average weight of fabric 190/200 g/m<sup>2</sup>.



MANUFACTURER: SPARCO  
MODEL: 001521  
FIA STANDARD: 8856-2000



MANUFACTURER: SPARCO  
MODEL: 001511  
FIA STANDARD: 8856-2000

SIZE	COL	CODE	
38/39 - 46	<input type="checkbox"/>	001521..	Long
	<input type="checkbox"/>	001511..	Short



MANUFACTURER: SPARCO  
MODEL: TOP DELTA RW-6  
FIA STANDARD: 8856-2000

SIZE	COL	CODE	
XS/S - M/L - XL/XXL	<input type="checkbox"/>	001770MBI..	

Different mesh structure to provide better comfort and enhance breathability in different specific areas. Elastic ribbed neck band. The raglan sleeve pattern makes the garment more comfortable thanks to the stitching of the sleeves which is positioned in an area that is subjected to less pressure. The wrists and waist have finer stitching for increased comfort.



MANUFACTURER: SPARCO  
MODEL: BOTTOM DELTA RW-6  
FIA STANDARD: 8856-2000

SIZE	COL	CODE	
XS/S - M/L - XL/XXL	<input type="checkbox"/>	001771PBI..	

Different structure of the pants to provide better comfort and enhance breathability in different specific areas. Elastic, ribbed, mesh waist band edges. The ankles have finer stitching for increased comfort.



MANUFACTURER: SPARCO  
MODEL: BALACLAVA DELTA RW-6  
FIA STANDARD: 8856-2000

SIZE	COL	CODE	
SINGLE SIZE	<input type="checkbox"/>	001483BI	

Doppia struttura differenziata tra la parte anteriore e quella posteriore del sottocasco. Apertura occhi rifinita con bordo maglia per una maggiore resistenza all'usura.

Two different structure between the front and rear of the balaclava. Soft eye holes with mesh edges for improved resistance to wear and tear.

Doble estructura diferente entre la parte delantera y la trasera del sotocasco. Abertura para los ojos acabada con borde de punto para una mayor resistencia al desgaste.

SIZE	COL	CODE	
SINGLE SIZE	<input type="checkbox"/>	001484BI	



MANUFACTURER: SPARCO  
MODEL: BALACLAVA DELTA RW-6  
FIA STANDARD: 8856-2000



# NOT FIA APPROVED



Single layer balaclava specifically for all championships in which FIA/SFI type approved garments are not mandatory. Double differentiated structure between the front and rear of the balaclava. Soft eye holes with mesh edges for improved resistance to wear and tear.

SIZE	COL	CODE
SINGLE SIZE	<input type="checkbox"/>	001485BI..

Low neck, short sleeve T-shirt specifically for all championships in which FIA/SFI type approved garments are not mandatory. Differentiated mesh structure to provide better comfort and enhance breathability in different specific areas. Elastic low ribbed neck band. The raglan sleeve pattern makes the garment more comfortable thanks to the stitching of the sleeves which is positioned in an area that is subjected to less pressure. The wrists and waist have finer stitching for increased comfort.

SIZE	COL	CODE
XS/S - M/L - XL/XXL	<input type="checkbox"/>	001796TBI..

Bermuda shorts specifically for all championships in which FIA/SFI type approved garments are not mandatory. Differentiated mesh structure of the shorts to provide better comfort and enhance breathability in certain specific areas. Elastic, ribbed, mesh waist band edges.

SIZE	COL	CODE
XS/S - M/L - XL/XXL	<input type="checkbox"/>	001710BBI..



COL	CODE
<input type="checkbox"/>	00156N

Ginocchiere. Knee pads. Rodilleras



COL	CODE
<input type="checkbox"/>	00157N

Gomitiere. Elbow pads. Coderas



CINTURA CONTENIMENTO BRACCIA  
ARM RESTRAINTS  
CINTURÓN DE RETENCIÓN DE LOS BRAZOS

Arm restraints suggested for Dragster, Midget and Off Road racing. SFI 3.3 approved.

COL	CODE
<input type="checkbox"/>	00158SETRS
<input type="checkbox"/>	00158SETAZ
<input type="checkbox"/>	00158SETNR

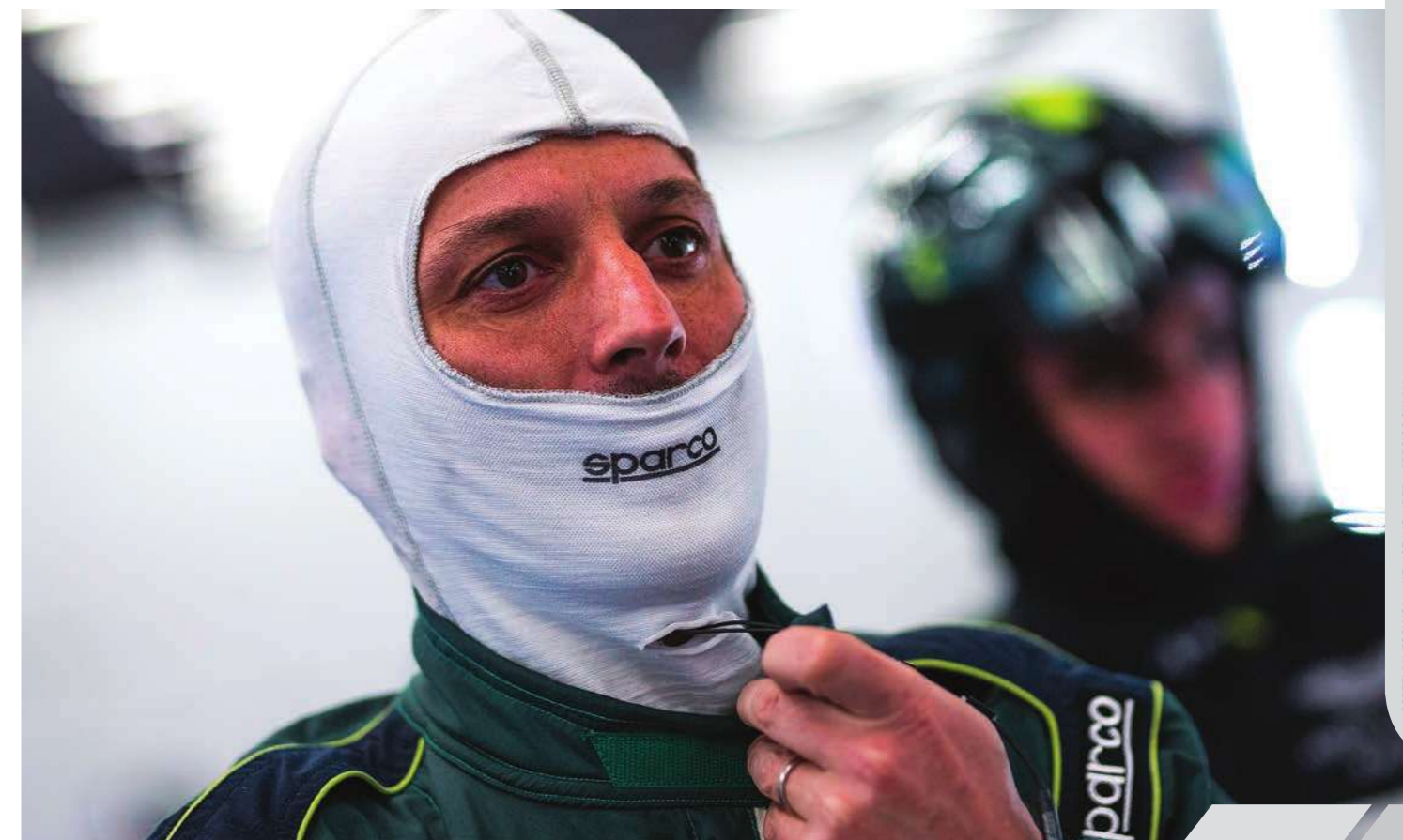



sparco®

OFFICIAL SUPPLIER OF YOUR PASSION

OFFICIAL SUPPLIER OF YOUR PASSION



OFFICIAL SUPPLIER OF YOUR PASSION



OFFICIAL SUPPLIER OF YOUR PASSION

sparco®

OFFICIAL SUPPLIER OF YOUR PASSION

OFFICIAL SUPPLIER OF YOUR PASSION

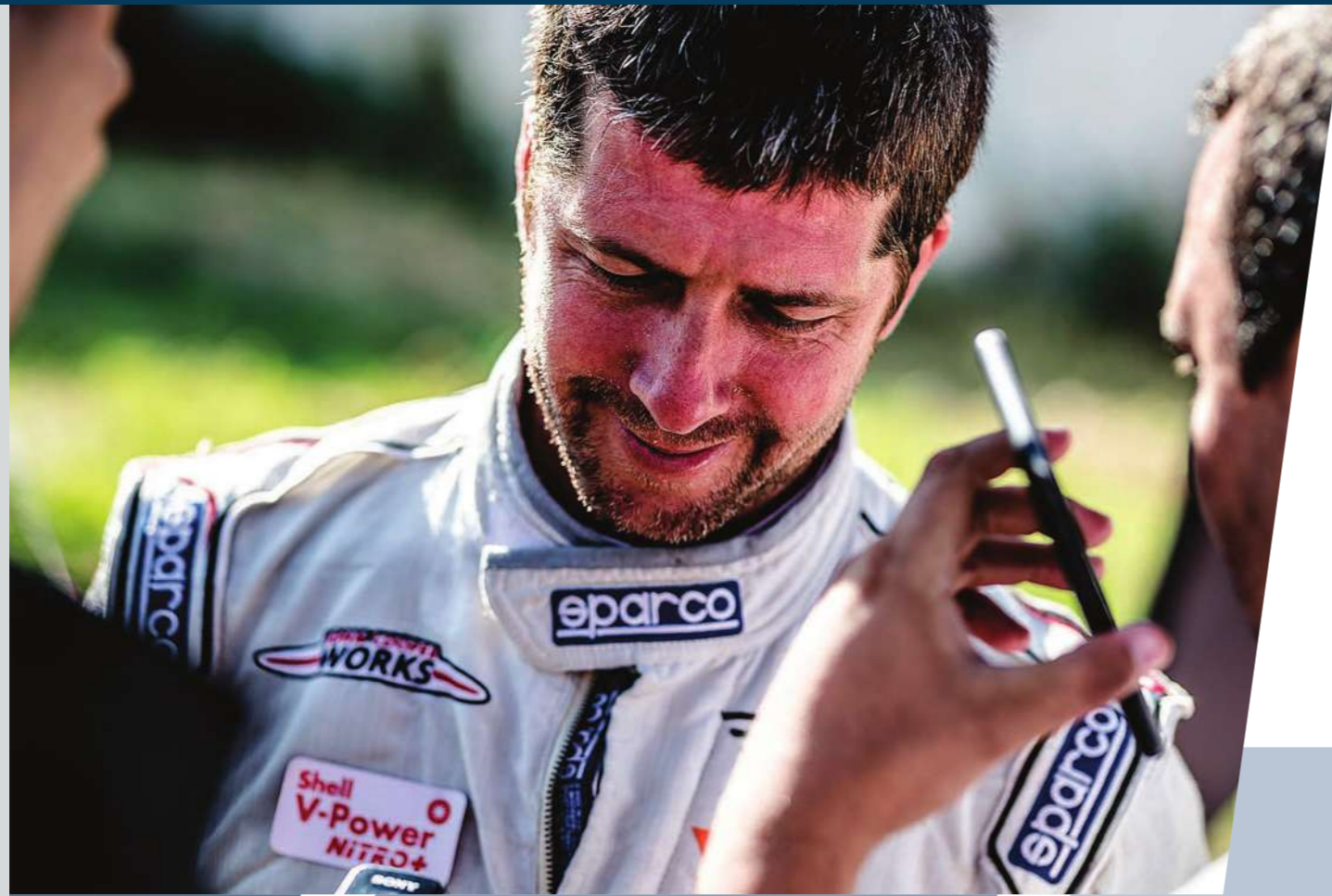

OFFICIAL SUPPLIER OF YOUR PASSION



OFFICIAL SUPPLIER OF YOUR PASSION



# RACING SHOES

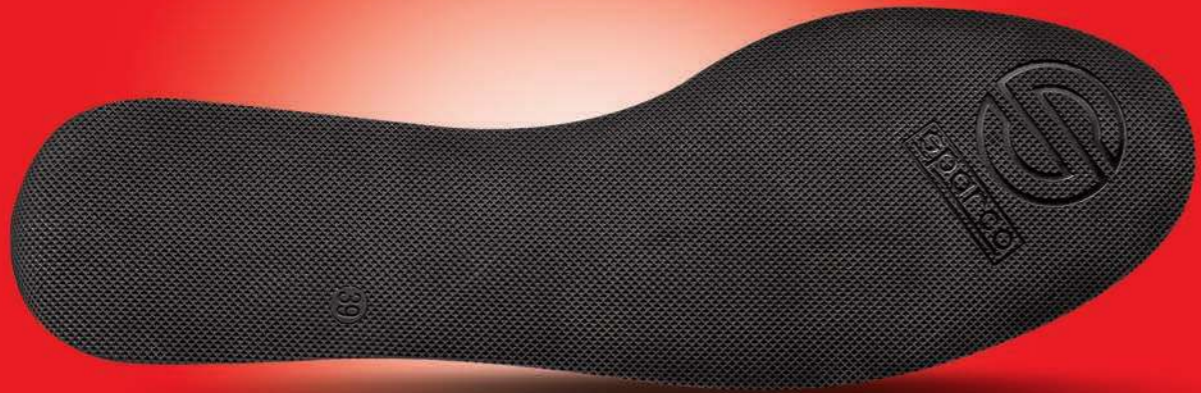

SUPERLEGGERA RB-10.1



FORMULA RB-8.1



APEX RB-7



SLALOM RB-3



SLALOM RB-3 CLASSIC



# RACING

## SUPERLEGGERA RB-10.1

FIA 8856-2000



Size: 38-48

Superleggera RB-10.1 race boots are made with a fire retardant fabric and can be personalised including the use of prints. The panels are made from lightweight kangaroo skin which is much more resistant than normal leather. The ultra-light soles conform perfectly to any heel. Integrated lateral reinforcement. The stretch fabric tongue wraps around the foot like a second skin and prevents dust, soil or other materials from entering the shoe. Superleggera RB-10.1 racing boots have an elastic panel at the rear just above the heel to improve fit and allow the ankle to move freely when driving.



MANUFACTURER: SPARCO  
MODEL: SUPERLEGGERA RB-10.1  
FIA STANDARD: 8856-2000



001237..NR

# RACING

## NEW FORMULA RB-8.1

FIA 8856-2000

SFI 3.3/5



Size: 37-48

**CHARACTERISTICS:** Adjustable strap on the ankle. Logos printed directly on the leather. Ventilated leather for breathability. Rapid and ultralight lacing system. New leather with soft-hand matte finish, secure wraparound feel: the foot is facilitated in its movements and the leather adapts to its shape. The elastic rear fabric aids the movements of the ankle. Lining in Cotton-Modacrylic fabric coupled with ultra-breathable expanded PU. Insole with shock absorber. Leather reinforcement side-panels to reduce impacts. Ultra-thin pure rubber sole, antistatic and with a special texture for better pedal grip.

**PERSONALISATION:** transfer printing - embroidery.



MANUFACTURER: SPARCO  
MODEL: RB-8.1  
FIA STANDARD: 8856-2000



001251..AZBI



001251..BINR



001251..NRAF (NO SFI)



001251..NRBI



001251..NRGF (NO SFI)



001251..RSBI



# NEW APEX RB-7

FIA 8856-2000



Size: 37-48



**CHARACTERISTICS:** Adjustable strap on the ankle. Logos printed directly on the leather. Area with ventilated leather for breathability. Rapid and ultralight lacing system with double tie option, either on the tongue or inside a special concealed compartment. Two types of leather, one with a soft-hand matte finish and a secure wraparound feel: the foot is facilitated in its movements and the leather adapts to its shape. The shoe also includes rubber leather for reinforcement and anti-abrasion. The elastic rear fabric aids the movements of the ankle. Lining in light fabric, wraparound and ultra-breathable. Insole with shock absorber. Ultrathin pure rubber sole, antistatic and with a special texture for better pedal grip.

**PERSONALISATION:** transfer printing - embroidery.

**APPROVED**

MANUFACTURER: SPARCO  
MODEL: RB-7  
FIA STANDARD: 8856-2000



001261..AZGR



001261..BIRS



001261..NRBI



001261..NRGI



# SLALOM RB-3

FIA 8856-2000



SFI 3.3/5

Size: 36-48



Suede racing boots. Possibility of customisation following Sparco guidelines.

**COMPOSITION:** Suede exterior. Leather insole. Natural rubber sole.

**APPROVED**

MANUFACTURER: SPARCO  
MODEL: SLALOM RB-3  
FIA STANDARD: 8856-2000



001235..RS



001235..AZ



001235..NR



001235..NRVF



# SLALOM RB-3 CLASSIC

FIA 8856-2000



Size: 36-48



Classic RB-3 racing boots are made from calf leather and can be personalised following Sparco guidelines.

**COMPOSITION:** the exterior of Slalom RB-3 boots is made of very high quality calf skin leather which has been softened. The insoles are made from leather and the soles are natural rubber.



MANUFACTURER: SPARCO  
MODEL: SLALOM RB-3  
FIA STANDARD: 8856-2000



001239..MA



001239..NR



## RALLY OVERSHOES

Size: S-XL

S (38.5-40), M (40-41.5), L (41.5-43), XL (43.5-45)

Overshoes in natural rubber, ideal for protecting shoe soles on wet or abrasive surfaces. Rally use.



002431..N

# sparco®



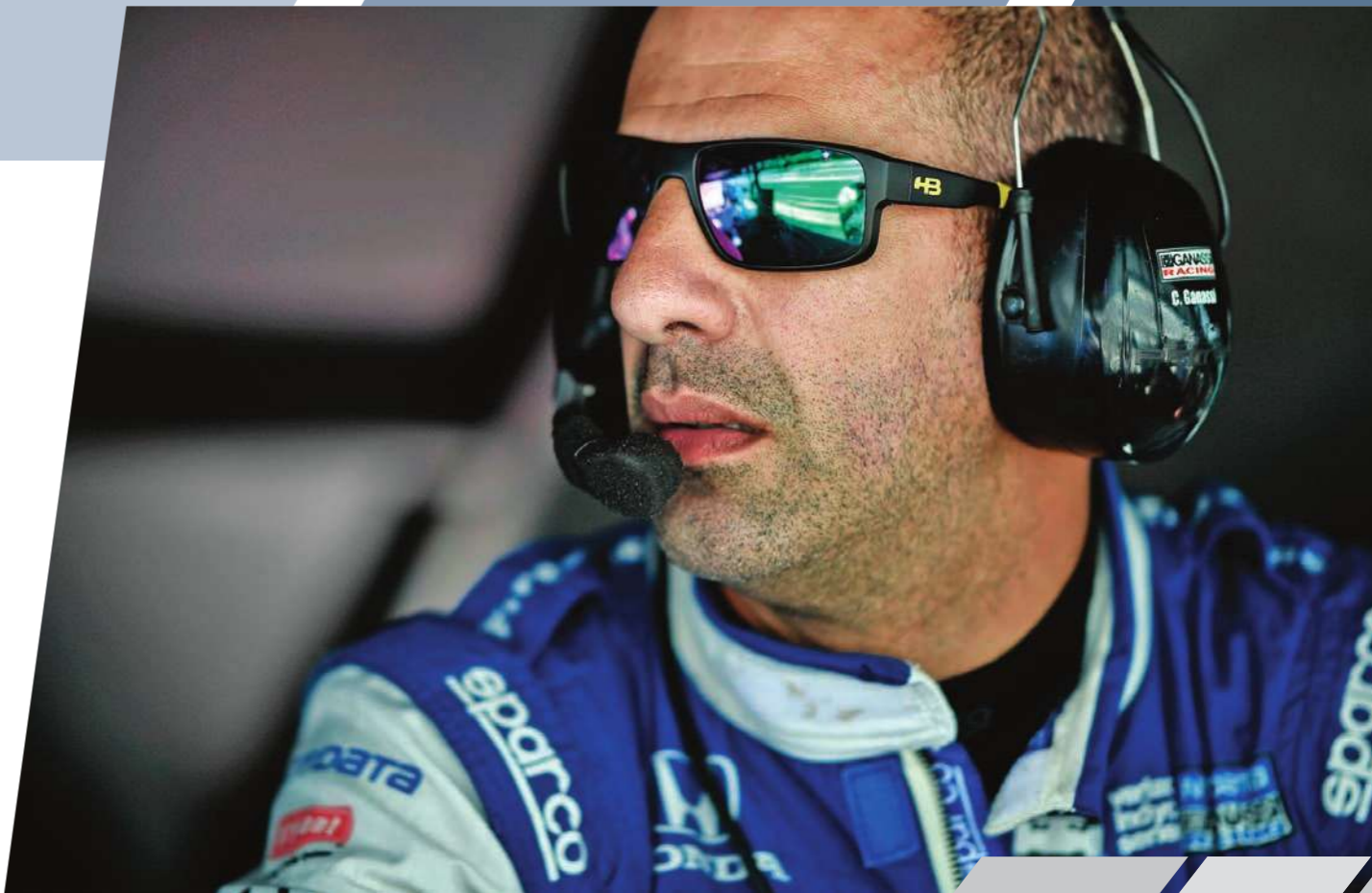



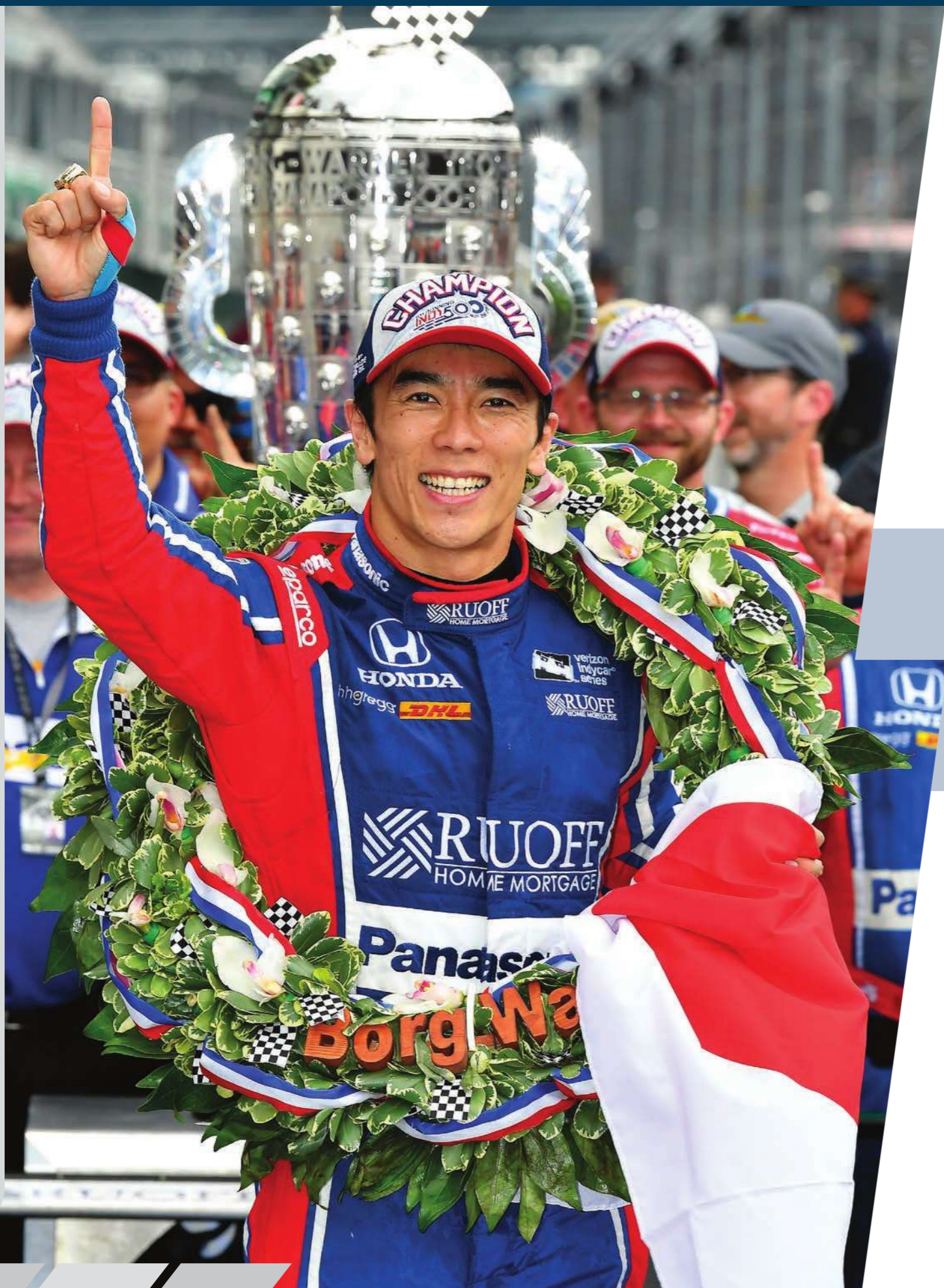



# RACING GLOVES

# TIDE RG-9

FIA 8856-2000	SFI 3.3/5	
HTX	Size: 7-12	

Gloves with external seams and preformed, high-grip, shock-absorbant, ergonomic palms. Possibility of customisation following Sparco guidelines.  
**COMPOSITION:** 100% meta-aramid jersey. Palm with 3D "Volcano" HTX reinforcements (Sparco patent). Back with 3D HTX reinforcements.



MANUFACTURER: SPARCO  
 MODEL: TIDE  
 FIA STANDARD: 8856-2000



0011355..RS



0011355..AZ



0011355..NR



0011355..BI



# NEW ARROW RG-7 EVO

FIA 8856-2000	SFI 3.3/5	
HTX	Size: 7-13	

**CHARACTERISTICS:** Pre-curved. Single-layer fabric on the back and between fingers, breathable and light. Back and fingers preformed, elastic wrist. Ergonomic profiling. Unique and FR patented technology: Touch Sensitive on index and thumb. Palm made of double-layer fabric using HTX technology, padding in the carpal region of the palm to reduce impact damage. New back graphic ready for personalisation.  
**PERSONALISATION:** transfer print.



001309..AZ



001309..BI



001309..NRGR



001309..NRRS



001309..RS



MANUFACTURER: SPARCO  
 MODEL: RG-7  
 FIA STANDARD: 8856-2000





# NEW LAP RG-5

FIA 8856-2000	SFI 3.3/5	
	Size: 8-12	

**COMPOSITION:** 93% meta-aramid mesh, 7% silicone.  
**CHARACTERISTICS:** differentiated stitching for improving the fitting; external in the palm and internal on the back and fingers. Back and fingers are preformed. Palm with new silicone grip, smooth to reduce bunching. Belt closure for wrist and inner elastics adjustment. Screen-printed back.  
**PERSONALISATION:** transfer print.



001311..RS



001311..AZ



001311..NR



001311..NRGF



001311..NRAF



MANUFACTURER: SPARCO  
 MODEL: RG-5  
 FIA STANDARD: 8856-2000



# LAND RG-3.1

FIA 8856-2000	SFI 3.3/5	
	Size: 8-12	

Gloves with internal seams, single-layer ultra-lightweight palm and quality suede inserts. Possibility of customisation following Sparco guidelines.

**COMPOSITION:** 100% meta-aramid jersey. Palm with suede reinforcements.



001308..RS



001308..AZ



001308..NR



MANUFACTURER: SPARCO  
 MODEL: RG3/RG4/RG5  
 FIA STANDARD: 8856-2000



# LAND CLASSIC (ON DEMAND)

FIA 8856-2000	SFI 3.3/1	
	Size: 8-12	

Gloves with internal seams, single-layer ultra-lightweight palm and quality suede inserts. Possibility of customisation following Sparco guidelines.  
**COMPOSITION:** 100% meta-aramid jersey. Palm with suede reinforcements.



MANUFACTURER: SPARCO  
 MODEL: RG3/RG4/RG5  
 FIA STANDARD: 8856-2000



001308..RS



001308..NR



sparco®





# RACING HELMETS

## PRIME RF-9W SUPERCARBON

### CARBON

SNELL SA 2015    FIA 8860-2010



COL	SIZE	CODE	
CARBON	XS	53-54	0033420XS
	S	55-56	00033421S
	M	57-58	0033422M
	M+	59	0033423ML
	L	60	0033424L
	XL	61	0033425XL



MANUFACTURER: VM SAFETY  
MODEL: SPARCO PRIME RF-9W  
HOM. NO: AH.029.17-C  
FIA STANDARD: 8860-2010

The Prime RF-9W helmet has a carbon fibre shell reinforced with carbon-Kevlar. Thanks to this manufacturing technology, the lightweight Prime RF-9W has excellent resistance. The shell and EPS are manufactured in two sizes and have been designed to ensure excellent ventilation. The interior linings can be removed, washed and repositioned. The Prime RF-9W helmet can accommodate a drink system and the visor (FIA approved) can be easily adjusted. The Prime RF-9W comes supplied with Hans® clips fitted. Available in 6 sizes.



## SKY RF-7W CARBON

### CARBON

SNELL SA 2015    FIA 8859-2015



COL	SIZE	CODE	
CARBON	XS	53-54	0033440XS
	S	55-56	00033441S
	M	57-58	0033442M
	M+	59	0033443ML
	L	60	0033444L
	XL	61	0033445XL



MANUFACTURER: VM SAFETY  
MODEL: SPARCO SKY RF-7W  
HOM. NO: PH.036.16-C  
FIA STANDARD: 8859-2015

The SKY RF-7W helmet has a carbon fibre shell reinforced with layers of carbon-Kevlar. The shell and EPS are manufactured in two sizes and has been designed to ensure excellent ventilation. The interior linings can be removed, washed and repositioned. The SKY-7W helmet can accommodate a drink system and the visor (FIA approved) can be easily adjusted. The SKY-7W comes supplied with Hans® clips fitted. Available in 6 sizes.



# AIR PRO RF-5W

## KEVLAR / FIBERGLASS

SNELL SA 2015    FIA 8859-2015



COL	SIZE	CODE	
WHITE	XS	53-54	0033450XS
	S	55-56	00033451S
	M	57-58	0033452M
	M+	59	0033453ML
	L	60	0033454L
	XL	61	0033455XL
XXL	62	0033456XXL	

COL	SIZE	CODE	
MATT BLACK	XS	53-54	0033450XSNR
	S	55-56	00033451SNR
	M	57-58	0033452MNR
	M+	59	0033453MLNR
	L	60	0033454LNR
	XL	61	0033455XLNR
XXL	62	0033456XXLNR	



MANUFACTURER: VM SAFETY  
MODEL: SPARCO SKY RF-5W  
HOM. NO: PH.037.16-C  
FIA STANDARD: 8859-2015



The AIR PRO RF-5W helmet has a carbon fibre shell reinforced with layers of carbon-Kevlar. The shell and EPS are manufactured in two sizes and have been designed to ensure excellent ventilation. The interior linings can be removed, washed and repositioned. The AIR PRO RF-5W helmet can accommodate a drink system and the visor (FIA approved) can be constantly adjusted. The AIR PRO RF-5W comes supplied with Hans® clips fitted. Available in 7 sizes and in two colours.

# CLUB-X1

## ATM

ECE 22-05    NOT FIA Homolog.

COL	SIZE	CODE	
WHITE	XS	53-54	0033190XS
	S	55-56	0033191S
	M	57-58	0033192M
	L	59	0033193L
	XL	60	0033194XL
	XXL	61	0033195XXL

COL	SIZE	CODE	
MATT BLACK	XS	53-54	003319N0XS
	S	55-56	003319N1S
	M	57-58	003319N2M
	L	59	003319N3L
	XL	60	0033194NXL
	XXL	61	0033195NXXL

ATM (Advance Thermo Material) shell. Removable and washable inner lining. Kart indoor  
Not homologated for FIA competition. Not fireproof.

### CLEAR VISOR



0032CLUBV01

### SMOKED VISOR



0032CLUBV02

### SILVER IRIIDIUM VISOR



0032CLUBV03

### VISOR FASTENER KIT



0032CLUBK01



## PRIME RJ-9i SUPERCARBON

### CARBON

SNELL SA 2015    FIA 8860-2010



COL	SIZE	CODE	
CARBON	XS	53-54	0033460XS
	S	55-56	0033461S
	M	57-58	0033462M
	M+	59	0033463ML
	L	60	0033464L
	XL	61	0033465XL



MANUFACTURER: VM SAFETY  
MODEL: ---  
HOM. NO: ---  
FIA STANDARD: 8860-2010

The Prime RJ-9i helmet has a carbon fibre shell reinforced with carbon-Kevlar. Thanks to this manufacturing technology, the lightweight Prime RJ-9i has excellent resistance. The shell and EPS are manufactured in two sizes and have been designed to ensure excellent ventilation. The interior linings can be removed, washed and repositioned. The Prime RJ-9i comes supplied with a professional communications system (adjustable carbon fibre boom, noise cancelling microphone, high quality speaker) and military grade connections (Nexus connector). The Prime RJ-9i comes supplied with Hans® clips fitted. Available in 6 sizes.



## SKY RJ-7i CARBON

### CARBON

SNELL SA 2015    FIA 8859-2015



COL	SIZE	CODE	
CARBON	XS	53-54	0033470XS
	S	55-56	00033471S
	M	57-58	0033472M
	M+	59	0033473ML
	L	60	0033474L
	XL	61	0033475XL



MANUFACTURER: VM SAFETY  
MODEL: SPARCO SKY RJ-7i  
HOM. NO: PH.041.16-0  
FIA STANDARD: 8859-2015

The SKY-RJ-7i helmet has a carbon fibre shell reinforced with carbon-Kevlar. The shell and EPS are manufactured in two sizes and have been designed to ensure excellent ventilation. The interior linings can be removed, washed and repositioned. The SKY RJ-7i comes supplied with a professional communications system (adjustable carbon fibre boom, noise cancelling microphone, high quality speaker) and military grade connections (Nexus connector). The SKY RJ-7i comes supplied with a carbon fibre peak and Hans® clips fitted. Available in 6 sizes.



## SKY RJ-7 CARBON

### CARBON

SNELL SA 2015    FIA 8859-2015



COL	SIZE	CODE	
CARBON	XS	53-54	0033480XS
	S	55-56	0033481S
	M	57-58	0033482M
	M+	59	0033483ML
	L	60	0033484L
	XL	61	0033485XL



MANUFACTURER: VM SAFETY  
MODEL: SPARCO SKY RJ-7  
HOM. NO: PH.041.16-O  
FIA STANDARD: 8859-2015

The SKY-RJ-7 helmet has a carbon fibre shell reinforced with carbon-Kevlar. The shell and EPS are manufactured in two sizes and have been designed to ensure excellent ventilation. The interior linings can be removed, washed and repositioned. The SKY RJ-7 comes supplied with a carbon fibre peak and Hans® clips fitted. Available in 6 sizes.



## AIR PRO RJ-5i

### KEVLAR / FIBERGLASS

SNELL SA 2015    FIA 8859-2015



COL	SIZE	CODE	
WHITE	XS	53-54	0033490XS
	S	55-56	00033491S
	M	57-58	0033492M
	M+	59	0033493ML
	L	60	0033494L
	XL	61	0033495XL
XXL	62	0033496XXL	

COL	SIZE	CODE	
MATT BLACK	XS	53-54	0033490XSNR
	S	55-56	00033491SNR
	M	57-58	0033492MNR
	M+	59	0033493MLNR
	L	60	0033494LNR
	XL	61	0033495XLNR
XXL	62	0033496XXLNR	



MANUFACTURER: VM SAFETY  
MODEL: SPARCO PRO RJ-5i AIR  
HOM. NO: PH.041.16-O  
FIA STANDARD: 8859-2015

The AIR PRO RJ-5i helmet has a carbon fibre shell reinforced with carbon-Kevlar. The shell and EPS are manufactured in two sizes and have been designed to ensure excellent ventilation. The interior linings can be removed, washed and repositioned. The AIR PRO RJ-5i comes supplied with a professional communications system (adjustable carbon fibre boom, noise cancelling microphone, high quality speaker) and military grade connections (Nexus connector). The AIR PRO RJ-5i comes supplied with a colour coded carbon fibre peak and Hans® clips fitted. Available in 7 sizes and in two colours.



# PRO RJ-3i

## KEVLAR / FIBERGLASS

SNELL SA 2015 FIA 8859-2015



COL	SIZE	CODE	
WHITE	XS	53-54	0033520XS
	S	55-56	0033521S
	M	57-58	0033522M
	M+	59	0033523ML
	L	60	0033524L
	XL	61	0033525XL
	XXL	62	0033526XXL



MANUFACTURER: VM SAFETY  
MODEL: SPARCO PRO RJ-3i  
HOM. NO: PH.041.16-O  
FIA STANDARD: 8859-2015

The AIR PRO RJ-3i helmet has a fibreglass shell reinforced with carbon-Kevlar. The shell and EPS are manufactured in two sizes and have been designed to ensure excellent ventilation. The interior linings can be removed, washed and repositioned. The PRO RJ-3i comes supplied with a professional communications system (adjustable carbon fibre boom, noise cancelling microphone, high quality speaker) and military grade connections (Nexus connector). The AIR PRO RJ-3i comes supplied with Hans® clips fitted. Available in 7 sizes.



# PRO RJ-3

## KEVLAR / FIBERGLASS

SNELL SA 2015 FIA 8859-2015



COL	SIZE	CODE	
WHITE	XS	53-54	0033530XS
	S	55-56	0033531S
	M	57-58	0033532M
	M+	59	0033533ML
	L	60	0033534L
	XL	61	0033535XL
	XXL	62	0033536XXL



MANUFACTURER: VM SAFETY  
MODEL: SPARCO PRO RJ-3  
HOM. NO: PH.041.16-O  
FIA STANDARD: 8859-2015

The PRO RJ-3 helmet has a fibreglass shell reinforced with carbon-Kevlar. The shell and EPS are manufactured in two sizes and have been designed to ensure excellent ventilation. The interior linings can be removed, washed and repositioned. The PRO RJ-3 comes supplied with Hans® clips fitted. Available in 7 sizes.





# CLUB-J1

ATM	
ECE 22-05	NOT FIA Homolog.

COL	SIZE	CODE
WHITE	XS	-54 0033170XS
	S	55-56 0033171S
	M	57-58 0033172M
	L	59-60 0033173L
	XL	61- 0033174XL

ATM (Advanced Thermo Material) shell. ECE approved. Anti-dazzle peak. Hypoallergenic lining. Sizes XS (54) - XL (61). Not homologated for FIA competition. Not fireproof.



# sparco®



### ACCESSORIES - JET HELMETS

= STANDARD/SPARE

= OPTION

	INTERCOM SYSTEM	BLACK ABS PEAK	WHITE ABS PEAK	MATT BLACK ABS PEAK	CARBON PEAK 8859	CARBON PEAK 8860	CARBON BOOM 8859	SET OF SMALL MATT BLACK AIR INTAKES	SET OF SMALL WHITE AIR INTAKES
PRIME RJ-9i	FACTORY FITTED	00316F01	00316F03	00316F02	00316F04	00316F05	537010	00315K04	0032WTXK06
SKY RJ-7i	FACTORY FITTED	00316F01	00316F03	00316F02	00316F04	00316F05	537010	00315K04	0032WTXK06
SKY RJ-7	AVAILABLE	00316F01	00316F03	00316F02	00316F04	00316F05	537010	00315K04	0032WTXK06
AIR PRO RJ-5i WHITE	FACTORY FITTED	00316F01	00316F03	00316F02	00316F04	00316F05	537010	00315K04	0032WTXK06
AIR PRO RJ-5i BLACK	FACTORY FITTED	00316F01	00316F03	00316F02	00316F04	00316F05	537010	00315K04	0032WTXK06
PRO RJ-3i	FACTORY FITTED	00316F01	00316F03	00316F02	00316F04	00316F05	537010	00315K04	0032WTXK06
PRO RJ-3	AVAILABLE	00316F01	00316F03	00316F02	00316F04	00316F05	537010	00315K04	0032WTXK06

### ACCESSORIES - FULL FACE HELMETS

= STANDARD/SPARE

= OPTION

	CLEAR VISOR	DARK VISOR	BLUE IRIIDIUM VISOR	SILVER IRIIDIUM VISOR	SET OF 5 TEAR-OFFS	VISOR FASTENER KIT	CENTRAL MATT BLACK AIR INTAKE	SET OF SMALL MATT BLACK AIR INTAKES	CENTRAL WHITE AIR INTAKE	SET OF SMALL WHITE AIR INTAKES
PRIME RF-9W	00314V01	00314V02	00314V03	00314V04	00315K01	00315K02	00315K03	00315K04	0032WTXK04	0032WTXK06
SKY RF-7W	00314V01	00314V02	00314V03	00314V04	00315K01	00315K02	00315K03	00315K04	0032WTXK04	0032WTXK06
AIR PRO RF-5W WHITE	00314V01	00314V02	00314V03	00314V04	00315K01	00315K02	00315K03	00315K04	0032WTXK04	0032WTXK06
AIR PRO RF-5W BLACK	00314V01	00314V02	00314V03	00314V04	00315K01	00315K02	00315K03	00315K04	0032WTXK04	0032WTXK06
AIR KF-7W	00314V01	00314V02	00314V03	00314V04	00315K01	00315K02	00315K03	00315K04	0032WTXK04	0032WTXK06
SKY KF-5W	00314V01	00314V02	00314V03	00314V04	00315K01	00315K02	00315K03	00315K04	0032WTXK04	0032WTXK06



CLEAR VISOR



DARK VISOR



SMOKED VISOR



BLUE IRIIDIUM VISOR



SET OF WHITE AIR INTAKES



SET OF CLEAR AIR INTAKES



VISOR FASTENER KIT



TEAR-OFF

### ACCESSORIES - FULL FACE HELMETS



CHEEK PADDING  
(Full face helmets)

THICKNESS (mm)	CODE
25	0032RF01ML
30	0032RF01MXLXXL
35	0032RF01SL
40	0032RF01XS



TOP PADDING  
(Full face and Jet helmets)

THICKNESS (mm)	CODE
10	0032R01XXL
15	0032R01MMLLXL
15+5	0032R01XSS

These kits allow for the best possible helmet fitting, with the right choice of thickness for the user's needs. Installation is simple and rapid, thanks to the Velcro fastenings.



FRONT SPOILER



REAR SPOILER



PUMPER

COL	SIZE	CODE
■	XS-M/L	00317P02
■	L-XXL	00317P04
□	XS-M/L	00317P01
□	L-XXL	00317P03

COL	CODE
■	00315K08
□	00315K07

COL	CODE
■	00315K10
□	00315K09



HELMET BAGS



CODE	003112NGR
------	-----------

HELMET NET RED



CODE	00313
------	-------



CODE	01666
------	-------



COSMOS

Helmet and HANS bag. 600 polyester fabric, neoprene and synthetic leather inserts. Drying system helmet with USB 12V power. Divider to increase the capacity of the bag. Adjustable shoulder strap. Two carry handles. Water resistant material. Ventilation cover.

DIMENSIONS	CODE
H 35 x L35 x P 40   50 Lt	016433NR



HELMET BOXES



New edition made of washable vinyl.

COL	CODE
	01662R
	01662A
	01662N

NECK SUPPORT COLLARS



Characterized by a special rear anatomic shape and variable density padding (more consistent in the helmet support area and softer under the chin and in the spoiler) in order to reduce the weight of the helmet on the back.



COL	CODE
	001603AZNR
	001603RSNR
	001603GRNR



COL	CODE
	001601AZNR
	001601RSNR
	001601GRNR

# HANS DEVICE



## ULTIMATE

- Weight: 490 g (without padding)
- Improved fitting
- Sliding Tethers

CODE	00393U...	
DEGREE	SIZES	
20	M	
20	L	
30	M	
30	L	



## HI TECH

- Weight: about 550 g
- All sizes available
- Sliding Tethers

CODE	00391N...	
DEGREE	SIZES	
10	M	
20	S - M - L	
25	S	
30	M - L	
30	SPECIAL M - L	
40	M	

Thanks to the new trade agreement, Sparco is able to provide the best range of Head Restraint for sizes, structure, weight and price. Moreover, thanks to the usual care for its products, Sparco is the only factory able to provide to customers a full package compatible with the set (helmet, harness and seat)



## RACING 2

- Realized in high resistance PVC
- Weight: about 800 g
- Lighter structure
- Sliding Tethers
- Low price

CODE	00391RS...	
DEGREE	SIZES	
20	M/L - L/XL	



## CLUB

- Realized in high resistance PVC
- Weight: around 950 g
- Ergonomic design shape
- Sliding Tethers
- Low price

CODE	00391C...	
DEGREE	SIZES	
20	M/L - L/XL	

## DIGITAL INTERCOM BOX

## IS-150 BT

- Digital intercom control unit
- Digital noise cancelling with different preset adjustment levels
- Bluetooth connection with mobile devices
- "Race" mode to disable communication with mobile devices in special stages
- RCA jack for in-car camera
- Independent volume control between driver and navigator.
- Military grade Nexus connectors.

CODE	00537021
------	----------



## INTERCOM BOX

## IS-140

Professional intercom box designed to offer the best performance in communication during racing. The system has been developed with the help of the most important drivers and teams all over the world. The main strength of this accessory is the quality of communication: Regardless of the situation, it is clear and guarantees precise communication and additional safety to the crew. Advanced noise reduction filters adjustable in six different positions permit this box to be fitted in all cars, including noisier cockpits such as WRC and S2000.

CODE	00537016
------	----------



## IS-140 Technical specification:

- Independent volume adjusting (driver and co-driver)
- External shape is designed to fit easily to rollcage and panel
- Female Nexus military connectors
- Integrated internal cable for upgraded reliability
- Powered via a 9v PP3 battery (not supplied) or 12v car battery (integrated cable)
- 3 noise reduction filters, 2 different amplification possibilities for a total of 6 settings
- Developed for Sparco crash helmets but totally compatible with most common crash helmets on the market
- Automatic switched on once the co-driver crash helmet is plugged in
- ON/OFF led signal
- 3,5mm connector for mobile phone (I-Phone, Nokia, Samsung)
- RCA output for on board camera

## INTERCOM BOX

## IS-110

High quality intercom system designed for professionals that need a simple and economic product.  
High quality audio and easy-to-use system make this product perfect for a variety of uses.

## IS-110 Technical specification:

- One knob adjusts both driver and co-driver volumes
- External shape is designed to easily fit to rollcage and panel
- 6.3 mm high quality connectors
- Integrated internal cable for an upgraded reliability
- Powered via a 9v PP3 battery (not supplied) or 12v car battery (integrated cable)
- Knob to switch on
- ON/OFF led signal

CODE	00537009
------	----------



## HEADSETS

- Headphones designed for use on open road (rallies/time trials)
- Excellent noise cancelling headphones
- Adjustable microphone
- Connection by means of spiral cable and connector

## SPARCO HEAD NX1



CODE	00537023
------	----------

## SPARCO HEAD R



CODE	00537024
------	----------



## ACCESSORIES



Intercom kit for full-face helmets.

CODE	00537013	
------	----------	--



Intercom kit for jet helmets.

CODE	00537011	
------	----------	--



Phone cable for IS-140

Compatibile con - Compatible with  
I-Phone, Blackberry, Nokia, Samsung.

CODE	00537020	
------	----------	--



Adattatore Nexus F-F  
Nexus F-F adaptor  
Adaptador Nexus F-F

CODE	00537015	
------	----------	--



Adattatore Nexus M-M  
Nexus M-M adaptor  
Adaptador Nexus M-M

CODE	00537019	
------	----------	--



PRIME RJ-9i

CODE	00537004	
------	----------	--



SKY RJ-7i - AIR PRO RJ-5i

CODE	00537010	
------	----------	--

Noise cancelling microphone. Adjustable microphone position. Covered in carbon fibre made using innovative technologies. Compatible with PRIME RJ-9i, SKY RJ-7i and AIR PRO RJ-5i.

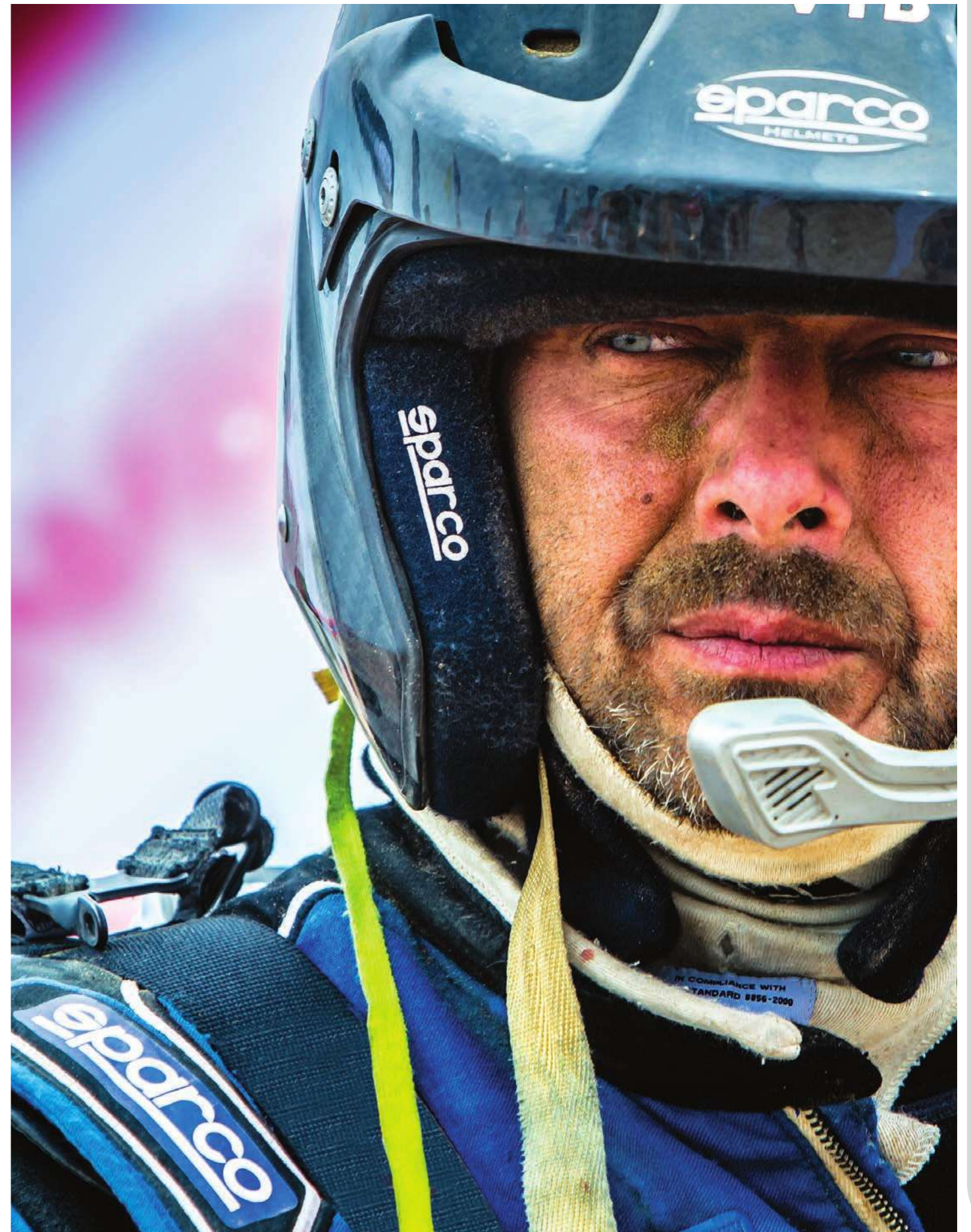



OFFICIAL SUPPLIER OF YOUR PASSION







OFFICIAL SUPPLIER OF YOUR PASSION



sparco®

OFFICIAL SUPPLIER OF YOUR PASSION

OFFICIAL SUPPLIER OF YOUR PASSION

OFFICIAL SUPPLIER OF YOUR PASSION



OFFICIAL SUPPLIER OF YOUR PASSION





# RACING SEATS

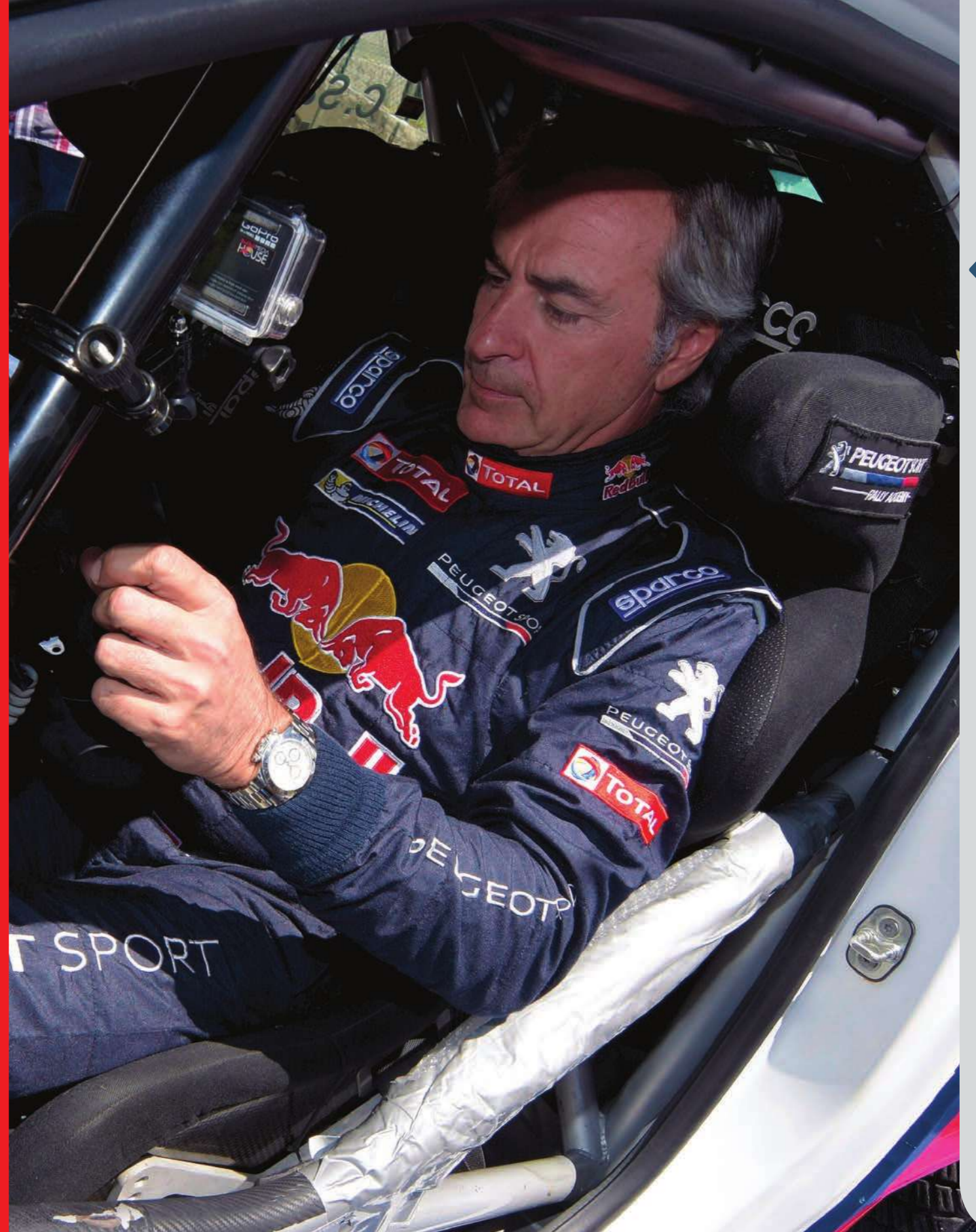

# NEW ADV XT

## CARBON

FIA 8862-2009



The lightest seat with FIA 8862 ever produced by Sparco. The driver seat has been improved to give greater comfort, for both road and circuit races. Self-extinguishing fabric. IA protection for areas in contact with the driver's body.



- staffe per attacco laterale 0049605.
- The seat is approved in conjunction with the side mounting frames 0049605.

CODE	0049605
------	---------

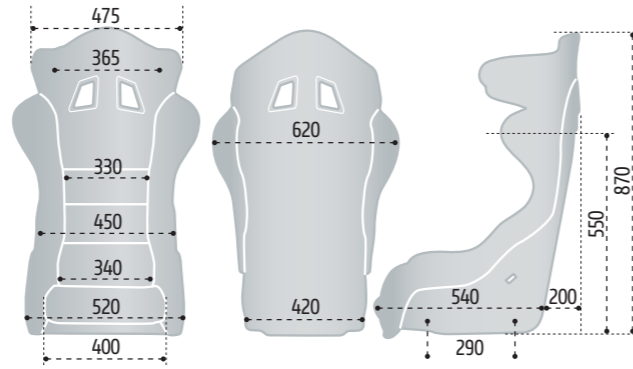

	SIZE	COL	CODE
ADV XT	L	7,5	008002ZNR

carbonTech



MANUFACTURER: SPARCO  
MODEL: ADV XT  
HOM. NO: AS.064.17  
FIA STANDARD: 8862-2009



# ADV ELITE

## CARBON

FIA 8862-2009



### THE LIGHTEST

FIA 8862 compliant. Lightest in this category.  
Self extinguish fabric.  
IA protection in specific areas (body contact).  
Lateral fixing (290 mm).



- Il sedile è omologato in abbinamento con le staffe per attacco laterale 004988ADV.
- The seat is approved in conjunction with the side mounting frames 004988ADV.
- El asiento esta homologado juntos con los soportes laterales 004988ADV.

CODE 004988ADV

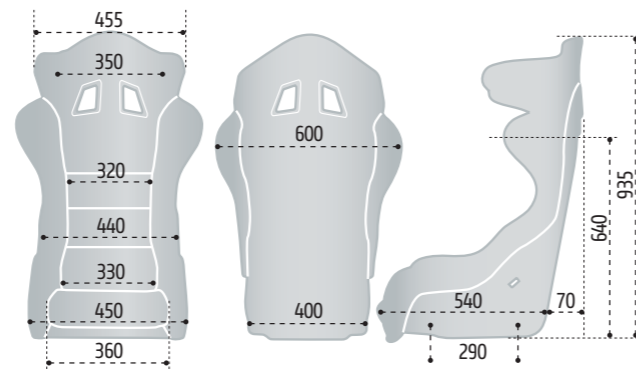

	SIZE	COL	CODE
ADV ELITE	Regular	7,8	00849ZNR

carbonTech



MANUFACTURER: SPARCO  
MODEL: ADV ELITE  
HOM. NO: AS.037.14  
FIA STANDARD: 8862-2009



# ADV SCX SCX-H

## CARBON

FIA 8862-2009



**REALLY RESISTANT: 70 G, MORE THAN 3000 Kg**

High lateral impact protection. Impact absorber material in body contact areas. Self-extinguishing fabric.

staffe per attacco laterale:

- The seat is approved in conjunction with the side mounting frames:

ADV SCX	CODE	004985ADV	
ADV SCX-H	CODE	004984ADV	



MANUFACTURER: SPARCO  
MODEL: ADV SCX H  
HOM. NO: AS.016.11  
FIA STANDARD: 8862-2009

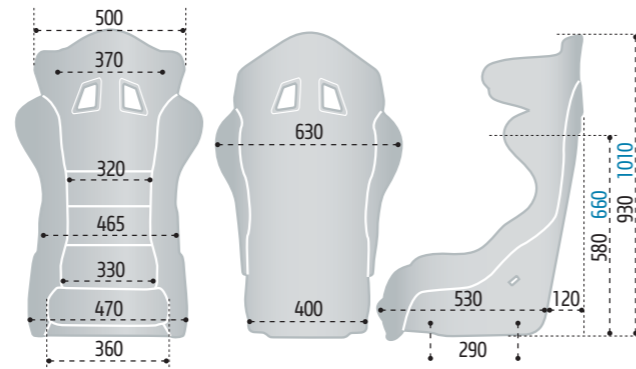

	SIZE	COL	CODE
ADV SCX	S/M	8,25	00804ZNR
ADV SCX-H	L	9,5	00805ZNR



ADV SCX-H

carbonTech



MANUFACTURER: SPARCO  
MODEL: ADV SCX  
HOM. NO: AS.022.12  
FIA STANDARD: 8862-2009



ADV SCX

# PRO ADV

**CARBON**

FIA 8855-1999



**ULTRALEGGERO  
ULTRALIGHT SHELL  
BASTIDOR ULTRALIGERO**

Simplified and lighter version for ADV SC  
8855-1999 homologated  
Large head and shoulder protectors  
Maximum safety and lightness



MANUFACTURER: SPARCO  
MODEL: PRO ADV CF  
HOM. NO: CS.351.17  
FIA STANDARD: 8855-1999

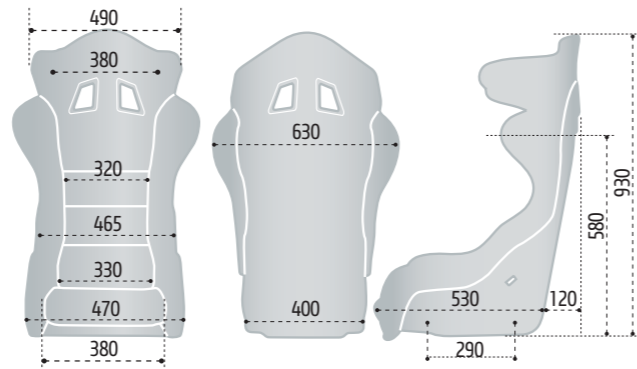

	SIZE	COL	CODE
PRO ADV	Regular	5,3	008093ZNR

**sparco**

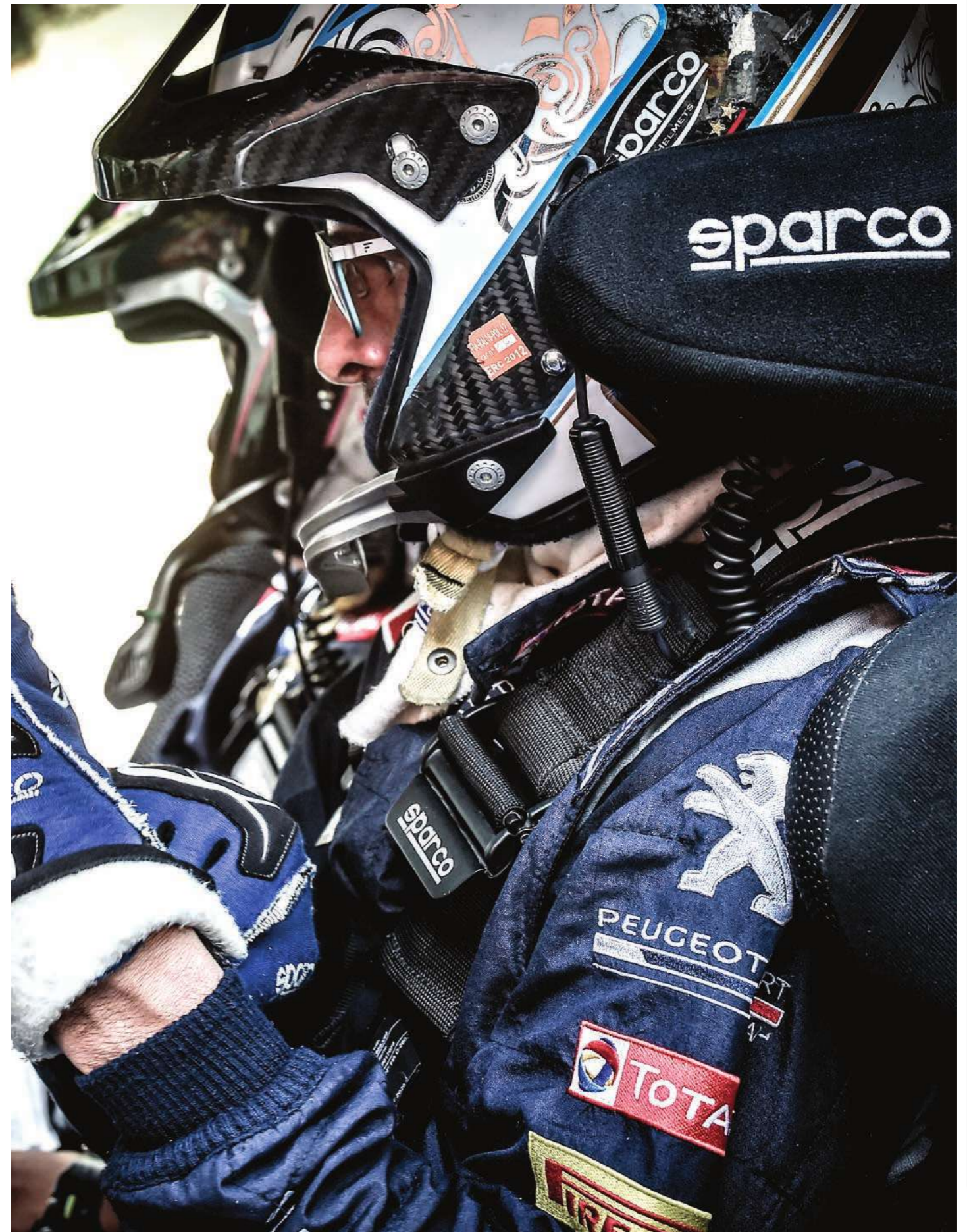



sparco®

OFFICIAL SUPPLIER OF YOUR PASSION

OFFICIAL SUPPLIER OF YOUR PASSION

OFFICIAL SUPPLIER OF YOUR PASSION



OFFICIAL SUPPLIER OF YOUR PASSION





# QRT TECHNOLOGY

The Quick Resin Technology (QRT), invented and industrialized by Sparco, allows for quick and uniform fusion of the seat frame, resulting in a significant reduction in the product's mass through the improved dosage of resin.

This technology improves fibre arrangement within the frame, while the innovative transfer of resin results in unparalleled mechanical strength/weight ratios for fibreglass sports seats.

The technology, created in Italy by Sparco's R&D Composite and Racing Equipment departments, has been developed over the years to stabilize production, considerably reducing the static dispersion of the seat weight. Through QRT, this parameter has been consolidated, bringing the standard deviation of the weight of the new seats to very low levels: the weight of the frames has decreased by about 3 kg, thus achieving a 45% improvement.

QRT, designed and developed by Sparco, is destined to generate the world's lightest fibreglass frames and to determine the properties of the sports seats of the future.

**NEW**  
**QRT-V**

**QRT / FIBERGLASS TECH**

FIA 8855-1999



QRT-V seat: L size shell, designed with the state-of-the-art CAD software. New design also for the seat belt slider. This shell is easily installable, also in the smallest of cockpits. Two configurations available: "traditional saddling" and sky.

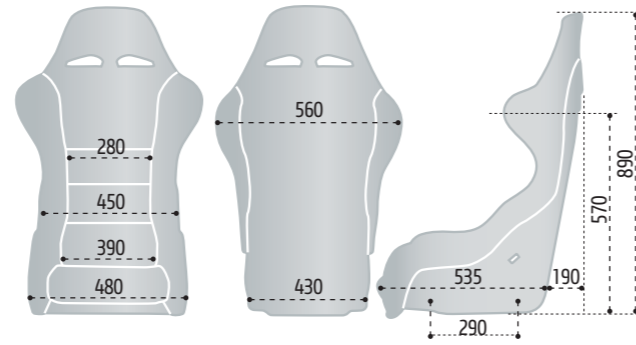

	SIZE	COL	CODE
QRT-V	L	4,5	008003RNR
QRT-V SKY	L	4,5	008003RNRSKY



**QRT-V SKY**

**FIA APPROVED**  
MANUFACTURER: SPARCO  
MODEL: ---  
HOM. NO: ---  
FIA STANDARD: 8862-2009

*quick resin* **TECH**

**FIA APPROVED**  
MANUFACTURER: SPARCO  
MODEL: ---  
HOM. NO: ---  
FIA STANDARD: 8862-2009



**QRT-V**

sparco®

OFFICIAL SUPPLIER OF YOUR PASSION

OFFICIAL SUPPLIER OF YOUR PASSION

OFFICIAL SUPPLIER OF YOUR PASSION



OFFICIAL SUPPLIER OF YOUR PASSION



# ERGO LF

## LF II

FIBERGLASS

FIA 8855-1999



CAD design ensures perfect fit for drivers, safety harness and HANS device.  
 DTC system, removable head protection.  
 HANS compatible.  
 Innovative shell design and use of special materials ensures both lightweight and rigid construction.  
 Non-slip Kinderpoint fabric on lower cushion and shoulders for maximum restraint and comfort.  
 Anatomic lower cushion and backrest with high breathability fabric for added comfort.  
 High resistance material in high wear areas.

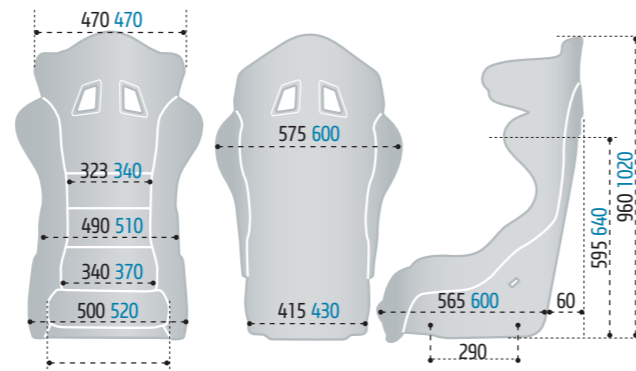

	SIZE	COL	CODE
ERGO LF	S/M	7,9	008722NR2M
ERGO LF II	L	8,0	008722NR3L



ERGO LF II



# GRP LIGHT 8855



MANUFACTURER: SPARCO  
 MODEL: ERGO L LF  
 HOM. NO: CS.344.16  
 FIA STANDARD: 8855-1999



New lower cushion sewed in one piece with backrest, made with impact absorbent padding, thinner, lighter, more comfortable (available also as an optional). 2 sizes S/M and L.



ERGO LF

# PRO-ADV TS

FIBERGLASS

FIA 8855-1999



The DTC is 400 mm to improve mounting options in smaller cockpits.  
 Head restraint reviewed to help support driver when cornering resulting in less fatigue on the neck  
 Shoulder and leg restraints to improve ergonomics. Ergonomic cushion.  
 Bigger hole for the 5th seat belt strap to avoid having to disassemble the lap strap to remove the seat.  
 Weight: 2 kg less than standard Pro-Adv

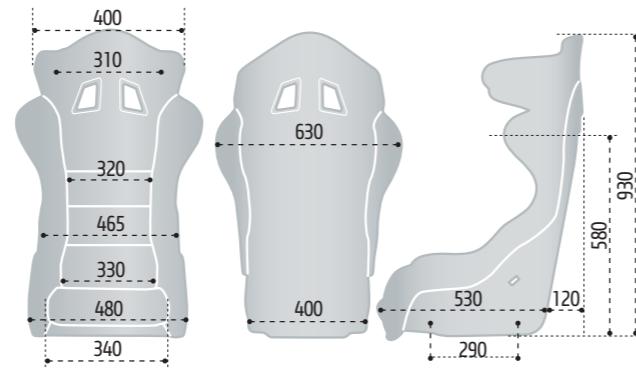

	SIZE	COL	CODE
PRO-ADV TS	Regular	7,5	008094FNR



GRP LIGHT 8855



MANUFACTURER: SPARCO  
 MODEL: PRO ADV TS  
 HOM. NO: CS.298.13  
 FIA STANDARD: 8855-1999



# ALPHA

FIBERGLASS

FIA 8855-1999



Fibreglass monocoque seat, ultralight lamination with reinforced panels in areas subjected to major mechanical stress. Lateral fixings 290 mm apart. Base fittings compatible with universal frames. Ultra-resistant cover with tear proof reinforcements in areas most affected by wear. Low seat cushion for better sensitivity at the wheel. Designed for very tall drivers of L/XL and greater size.



MANUFACTURER: SPARCO  
MODEL: ALPHA LF  
HOM. NO.: CS.357.17  
FIA STANDARD: 8855-1999

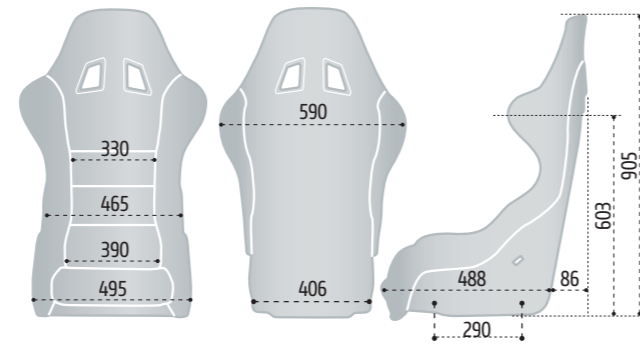

	SIZE	W	COL	CODE
ALPHA	L/XL	7,6	■	008001FNR

# PRO-ADV LF

FIBERGLASS

FIA 8855-1999



ADV SC FIBERGLASS VERSION



MANUFACTURER: SPARCO  
MODEL: PRO ADV LF  
HOM. NO.: CS.353.17  
FIA STANDARD: 8855-1999

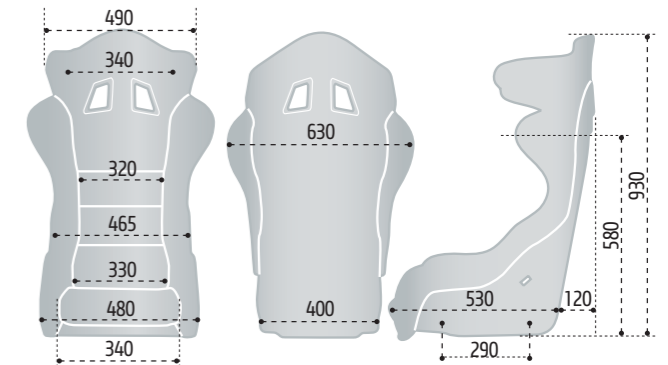

	SIZE	W	COL	CODE
PRO-ADV LF	Regular	10,0	■	008093FNR

# CIRCUIT LF LF II

FIBERGLASS

FIA 8855-1999



Integrated DTC system.  
No-slip fabric for shoulders and cushion.  
Smooth and slim backrest for high lateral support.  
Lateral fixing (290 mm).  
For track racing.



MANUFACTURER: SPARCO  
MODEL: CIRCUIT II  
HOM. NO: CS.303.14  
FIA STANDARD: 8855-1999



CIRCUIT LF II



MANUFACTURER: SPARCO  
MODEL: CIRCUIT LF  
HOM. NO: CS.325.15  
FIA STANDARD: 8855-1999

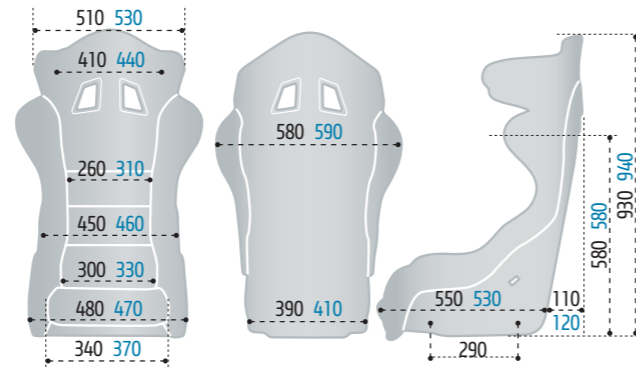

	SIZE	W	COL	CODE
CIRCUIT LF	M/L	7,45	■	008063FNR
CIRCUIT LF II	L/XL	7,83	■	008133FNR

# PRO 2000 LF LF II

FIBERGLASS

FIA 8855-1999



No-slip fabric for shoulders and cushion.  
Backrest with 2 lumbar supports and a slim cushion design.  
Lateral fixing (290 mm).  
Lower fixing available.  
Pro 2000 LF: for M size drivers.  
Pro 2000 LF II: for L size drivers.



MANUFACTURER: SPARCO  
MODEL: PRO 2000 II  
HOM. NO: CS.304.14  
FIA STANDARD: 8855-1999



PRO 2000 LF II



MANUFACTURER: SPARCO  
MODEL: PRO 2000 LF  
HOM. NO: CS.322.15  
FIA STANDARD: 8855-1999

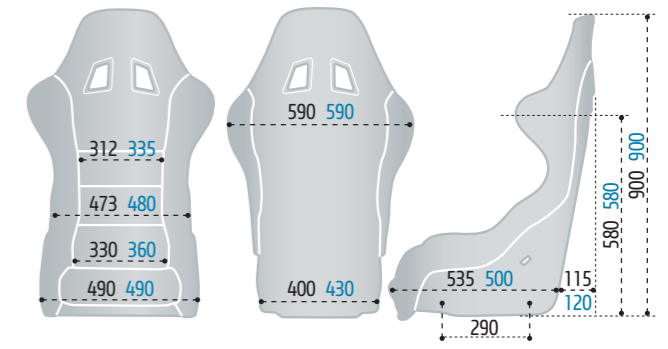

	SIZE	W	COL	CODE
PRO2000 LF	M/L	6,9	■	008083FNR
PRO2000 LF II	L/XL	6,7	■	008273FNR



# EVO LF

## LF II

FIBERGLASS

FIA 8855-1999



Fiberglass seat in 2 sizes  
 Non-slip fabric for shoulders and seat  
 Split cushion  
 Evo II: L size  
 larger and higher,  
 with space for the Hans collar



MANUFACTURER: SPARCO  
 MODEL: EVO II LF  
 HOM. NO: CS.342.16  
 FIA STANDARD: 8855-1999



EVO LF II



MANUFACTURER: SPARCO  
 MODEL: EVO LF  
 HOM. NO: CS.323.15  
 FIA STANDARD: 8855-1999

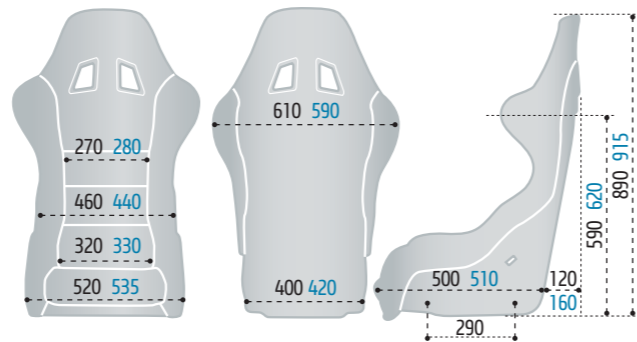

	SIZE	W	COL	CODE
EVO LF	M	6,6	■	008072FNR
EVO LF II	L	7,7	■	008282FNR

# REV

## REV II

FIBERGLASS

FIA 8855-1999



Fiberglass monocoque seat. Lateral fixings 290 mm apart. Ultra-resistant cover with tear proof reinforcements in areas most affected by wear. New lower seat cushion for better sensitivity at the wheel. NEW XL SIZE - Despite the XL size, the outer dimensions of the seat are compact making it ideal for use in small competition cars.



MANUFACTURER: SPARCO  
 MODEL: REV II LF  
 HOM. NO: CS.340.16  
 FIA STANDARD: 8855-1999



REV II



MANUFACTURER: SPARCO  
 MODEL: REV LF  
 HOM. NO: CS.339.16  
 FIA STANDARD: 8855-1999

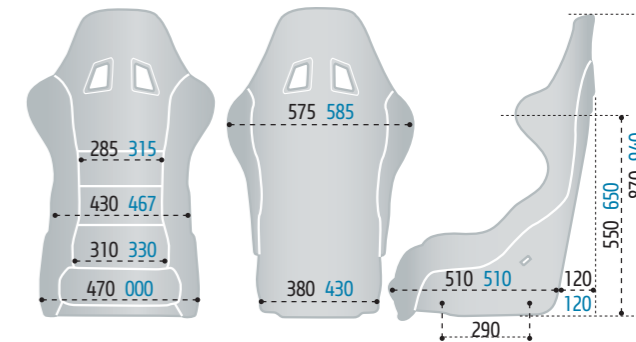

	SIZE	W	COL	CODE
REV	M/L	6,6	■	008143FNR
REV II	L/XL	7,9	■	008142FNR

# GRID II

FIBERGLASS

FIA 8855-1999



High leg protection. Shoulders are free to move due to specific shape of the shell.  
 Glass fiber racing seat with detachable cover and adjustable padding fixed to the seat frame by Velcro.  
 It is possible to customize the padding  
 Lateral fixing (290 mm).

**FIA APPROVED**  
 MANUFACTURER: SPARCO  
 MODEL: DRIFTING II  
 HOM. NO: CS.328.15  
 FIA STANDARD: 8855-1999

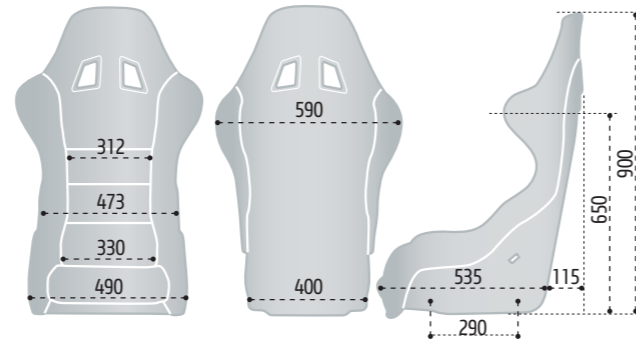

	SIZE	W	COL	CODE
GRID II	L/XL	7,2	■	008802FNR



# sparco®



# SPRINT

## SPRINT L

### STEEL TUBULAR FRAME

FIA 8855-1999



Steel tubular frame. Elastic strap containment. Lateral fixing holes. Lower fixing holes. A fifth harness slot to allow for 5 or 6 point harness fitment. SPRINT: for M size drivers. SPRINT L: for L size drivers.

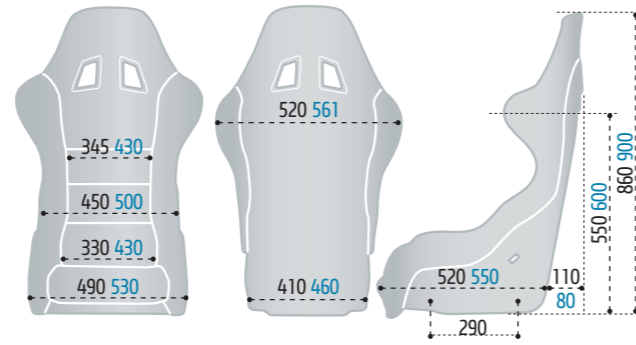

	SIZE	COL	CODE
SPRINT	Regular	7,39	008231NR
			008231AZ
			008231RS
SPRINT L	L/XL	-	008232LNR
			008232LAZ
			008232LRS



MANUFACTURER: SPARCO  
MODEL: SPRINT L  
HOM. NO: CS.314.15  
FIA STANDARD: 8855-1999



SPRINT L



MANUFACTURER: SPARCO  
MODEL: SPRINT  
HOM. NO: CS.322.15  
FIA STANDARD: 8855-1999



# SPRINT SKY

## SPRINT SKY L

### STEEL TUBULAR FRAME

FIA 8855-1999



Tubular frame with backrest and seat structure with elastic. Ultra-resistant Sky (vinyl) fabric. Easy to clean with water only. Ideal for off-road vehicles and boats. Approved for bottom and side fixing. A fifth harness slot to allow for 5 or 6 point harness fitment. SPRINT SKY: for M size drivers. SPRINT SKY L: for L size drivers.

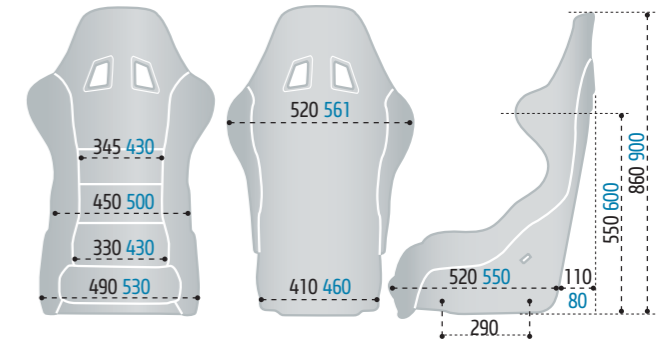

	SIZE	COL	CODE
SPRINT SKY	M/L	6,6	008232NRSKY
SPRINT SKY L	L/XL	7,9	008232LNRSKY



MANUFACTURER: SPARCO  
MODEL: SPRINT SKY L  
HOM. NO: CS.314.15  
FIA STANDARD: 8855-1999



SPRINT SKY L



MANUFACTURER: SPARCO  
MODEL: SPRINT SKY  
HOM. NO: CS.332.15  
FIA STANDARD: 8855-1999



**SUPPORTI A NORME FIA  
PER SEDILI CON ATTACCHI LATERALI**

**FIA-APPROVED MOUNTING FRAMES  
FOR SEATS WITH SIDE MOUNTING**

**SOPORTES CONFORME FIA  
PARA ASIENTOS CON  
SUJECIONES LATERALES**

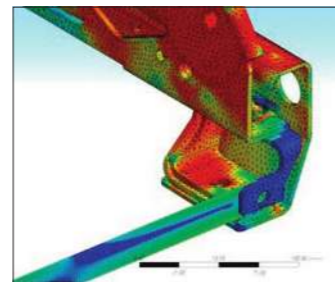
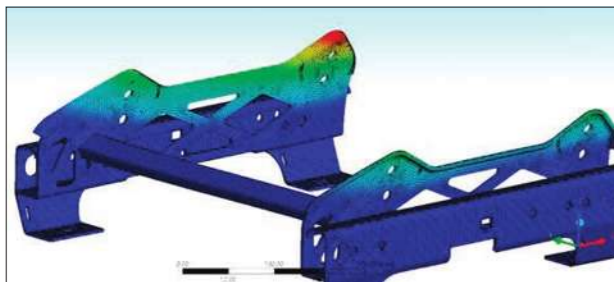

The 8862 sliding seat tracks were designed to offer drivers a wide range of driving positions (by means sliding back and forth and by tilting). Designed to comply with FIA8862 standards, these sliding tracks were optimised using the Finite Element Method (FEM). This approach and the use of high resistance steel and carbon fibre mean a light weight and very high safety standards. The sliding tracks can be adapted for the cockpits of all types of GT-Touring cars.



**QRT-V**

CODE	0049606	
------	---------	--

CODE	0049304 (ON DEMAND)	
------	---------------------	--



Longitudinal distance between holes 290 mm. 2 symmetrical pieces. Max length 415 mm. Simple mounting in the car with more than 25 positions. 6 mm anodized aluminium, FIA compliant. M8 mounting kit included.

CODE	004903	
------	--------	--



3 mm conforme FIA. Kit di montaggio M8 incluso. Longitudinal distance between holes 290 mm. 2 symmetrical pieces. Max length 400 mm. Simple mounting in the car with more than 25 positions. 3 mm black powder coated, FIA compliant. M8 mounting kit included.

CODE	004902	
------	--------	--

**SUBFRAMES FOR BOTTOM MOUNTING.**

FOR THE COMPLETE APPLICATION LIST SEE THE PRICE LIST



Dismountable mounting frame made of Steel. Maximum height and length adjustability. New L shape of the lateral element to allow a double lockage with the base element. New C shape of the base element to increase the grip of the lateral element. 22 eyelets on the base element.

CODE	00492LAT	
------	----------	--



Longitudinal wheelbase 290 mm. 3mm thick steel.

CODE	004901NR	
------	----------	--

DRIVER DRINK



Drink bag. Insulates from outside heat and keeps drinks at a constant temperature. Holds 1.5 litres, inner bottle and spout also available as spare parts. Four braces for attachment to the seat.



CODE	01045NR
------	---------

OPTIONAL PADDING



Headrest cushion

01008
-------



Leg support cushion

01011
-------



Pair of lumbar side backrests

01022
-------



Universal lumbar backrest

01023
-------

CUSCINO E SCHIENALE - BACKREST AND BASE CUSHIONS - RESPALDO Y FONDO DEL COJÍN



**ERGO**  
Size: S - M  
Colour: ■

01047KIT872NR1S
-----------------



**ERGO**  
Size: L  
Colour: ■

01047KIT872NR3L
-----------------



CUSCINO OPZIONALE - OPTIONAL CUSHION - COJÍN OPCIONAL



SEAT	mod.	CODE
ALPHA	A	01048A
REV II LF	A	01048A
REV LF	B	01048B
EVO LF	B	01048B
EVO II LF	A	01048A
PRO 2000 LF	A	01048A

SEAT	mod.	CODE
PRO 2000 II LF	A	01048A
CIRCUIT LF	C	01048C
CIRCUIT II LF	C	01048C
PRO-ADV LF	A	01048A
PRO-ADV TS	A	01048A
PRO-ADV CARB	A	01048A

sparco®

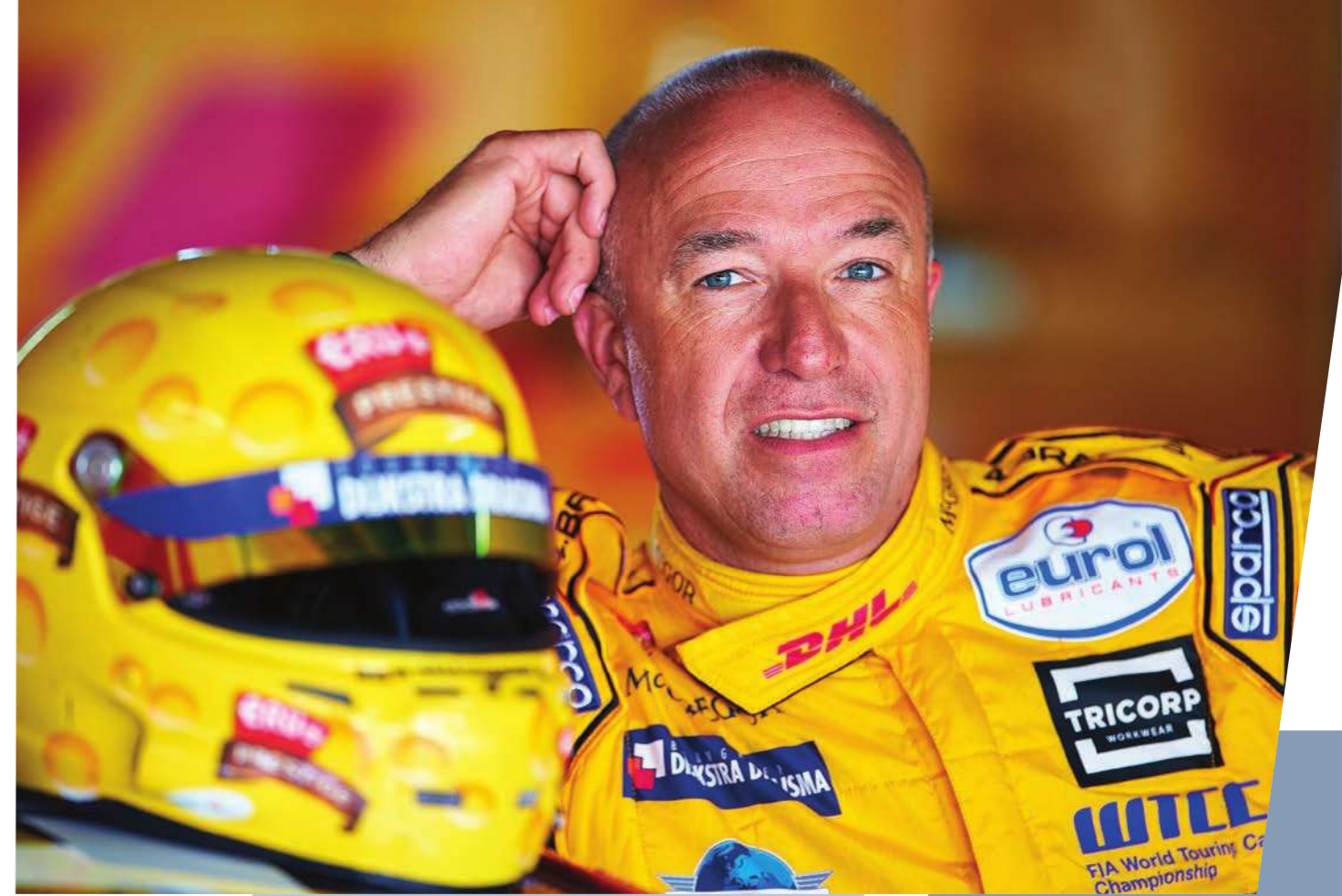







# RACING HARNESSES







Sparco's line of belts has been completely updated following the introduction of the new FIA 8853-2016 standard, which has considerably raised safety standards. FIA 8853-2016 approval has become compulsory for all manufacturers.

Belts are now subjected to a dynamic test involving a deceleration of 60 g (compared to the 30 g required by the previous standard); each belt must register an ultimate tensile strength of no less than 2500 kg.

In 2017, the new legislation was introduced in Formula 1, WRC and WTCC. Throughout the season, Sparco has been able to develop its line of Prime H9 belts through the valuable contribution of drivers and technicians from the world's most famous WRC teams.

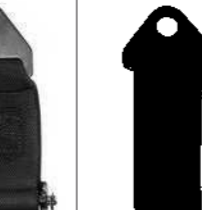
The Prime H9 belts stem from the need to drastically reduce the weight of the components installed in the vehicle, without compromising on functionality or safety. With this in mind, the Prime H9 belt components have been designed directly in Sparco and then tested in our laboratories and at the World Rally Championship trials.

					
PRIME H-9			•		
PRIME H-7			•		
04818RHAL	•				•
04818RH	•				•
04818RHALPD	•				
04818RAL	•				
04818RAC	•				•
04818RALPD	•			•	
04716M		•			•
04819H		•			

							
		•			•	•	
		•			•	•	
			•		•	•	
			•		•	•	
	•		•		•	•	
	•		•		•	•	
		•	•		•	•	
		•	•		•	•	
		•		•	•	•	•

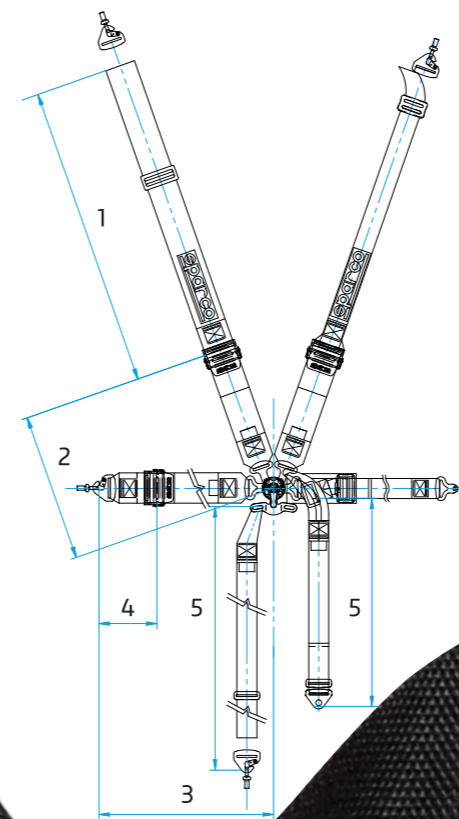

	1	2	3	4	5
	mm				
PRIME H-9	600	400	800	150	800
PRIME H-7	600	400	800	150	800
04818RHAL	1700	400	800	150	850
04818RH	1700	400	800	150	850
04818RHALPD	1700	400	700	150	850
04818RAL	2000	400	800	120	900
04818RAC	2000	400	800	120	900
04818RALPD	600	400	1000	-	850
04716M	1700	400	800	150	-
04819H	400	350	500	350	700





MANUFACTURER: SPARCO  
MODEL: 04820H  
HOM. NO: SH,----  
FIA STANDARD: 8853-2016



**NEW**  
**PRIME H-9**

FIA 8853-2016  

Hans specific shoulder trap (2")  
New steel adjusters  
New aluminium buckle  
Fastening to rollbar  
SPECTRA ribbon  
Weight < 1.30 kg

COL	CODE	
	04820HNR	
	04820HAZ	
	04820HRS	





MANUFACTURER: SPARCO  
MODEL: 04821H  
HOM. NO: SH,----  
FIA STANDARD: 8853-2016



**NEW**  
**PRIME H-7**

FIA 8853-2016  

Hans specific shoulder trap (2")  
New steel adjusters  
New aluminium buckle  
Fastening to rollbar  
POLYESTER ribbon  
Weight < 1.80 kg

COL	CODE	
	04821HNR	
	04821HAZ	
	04821HRS	





MANUFACTURER: SPARCO  
MODEL: 04818RH  
HOM. NO: SH.005.16-T-6  
FIA STANDARD: 8853-2016



**NEW**  
**04818RHAL**

FIA 8853-2016  

Hans specific shoulder strap (3" - 2")  
New aluminium adjusters  
New aluminium buckle  
Carabiner fasteners for all straps  
Fastening to rollbar to remove carabiner fastener

COL	CODE	
	04818RHALNR	
	04818RHALAZ	
	04818RHALRS	





MANUFACTURER: SPARCO  
MODEL: 04818RH  
HOM. NO: SH.005.16-T-6  
FIA STANDARD: 8853-2016



**NEW**  
**04818RH**

FIA 8853-2016  

Hans specific shoulder trap (3" - 2")  
New steel adjusters  
New aluminium buckle  
Carabiner fasteners for all straps  
Fastening to rollbar to remove carabiner fastener

COL	CODE	
	04818RHNR	
	04818RHHAZ	
	04818RHRS	



**FIA APPROVED**

MANUFACTURER: SPARCO  
MODEL: 04818RH  
HOM. NO: SH.005.16-T-6  
FIA STANDARD: 8853-2016



**NEW**  
**04818RHALPD**

FIA 8853-2016



Straps 3"  
New aluminium adjusters  
New aluminium buckle  
Carabiner fasteners for all straps  
Fastening to rollbar to remove carabiner fastener

COL	CODE	
■	04818RHALPDNR	
■	04818RHALPDAZ	
■	04818RHALPDRS	

**FIA APPROVED**

MANUFACTURER: SPARCO  
MODEL: 04818RH  
HOM. NO: SH.005.16-T-6  
FIA STANDARD: 8853-2016



**NEW**  
**04818RAL**

FIA 8853-2016



Straps 3"  
New aluminium adjusters  
New aluminium buckle  
Carabiner fasteners for all straps  
Fastening to rollbar to remove carabiner fastener

COL	CODE	
■	04818RALNR	
■	04818RALAZ	
■	04818RALRS	

**FIA APPROVED**

MANUFACTURER: SPARCO  
MODEL: 04818RH  
HOM. NO: SH.005.16-T-6  
FIA STANDARD: 8853-2016



**NEW**  
**04818RAC**

FIA 8853-2016



Straps 3"  
New steel adjusters  
New aluminium buckle  
Carabiner fasteners for all straps  
Fastening to rollbar to remove carabiner fastener

COL	CODE	
■	04818RACNR	
■	04818RACAZ	
■	04818RACRS	

**FIA APPROVED**

MANUFACTURER: SPARCO  
MODEL: 04818RH  
HOM. NO: SH.005.16-T-6  
FIA STANDARD: 8853-2016

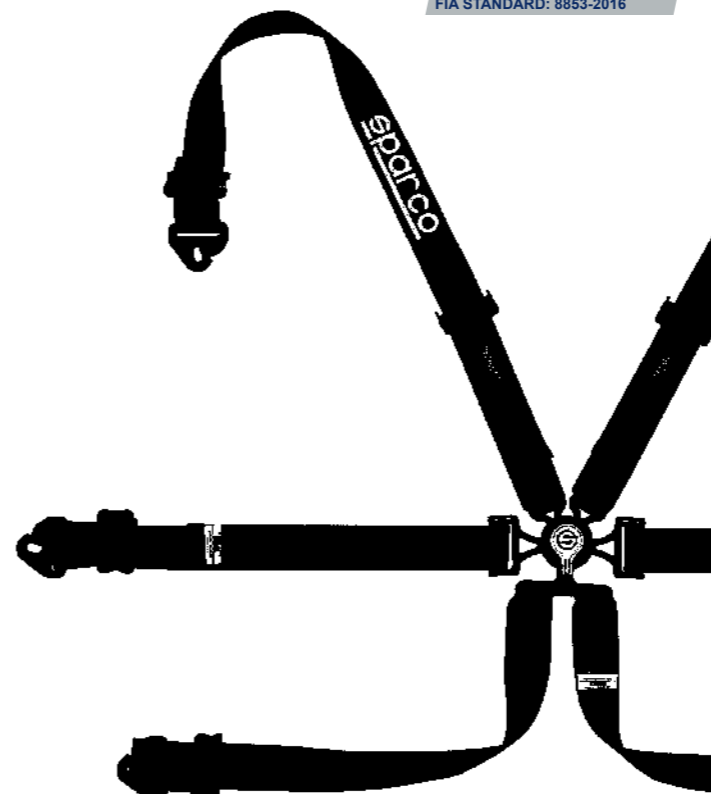

**NEW**  
**04818RALPD**

FIA 8853-2016



Six-point safety harness with 3"+2" shoulder straps for FHR and HANS Device systems  
Carabiner fasteners  
Abdominal pulldown adjustment near buckle  
Fastening to rollbar to remove carabiner fastener



COL	CODE	
■	04818RALPDNR	
■	04818RALPDAZ	
■	04818RALPDRS	





MANUFACTURER: SPARCO  
MODEL: 04716M  
HOM. NO: B----,T/98  
FIA STANDARD: 8854-1998



## NEW 04716M

FIA 8854-1998  

Shoulder and abdominal strap 3"  
New steel adjusters  
New aluminium buckle  
Carabiner fasteners for all straps

COL	CODE	
	04716MNR	
	04716MAZ	
	04716MRS	





MANUFACTURER: SPARCO  
MODEL: 04819H  
HOM. NO: SH----,16-T-6  
FIA STANDARD: 8853-2016



## NEW 04819H

FIA 8853-2016  

Steel adjusters, light version  
Aluminium buckle  
Screw fastening to frame



COL	CODE	
	04819HNR	
	04819HAZ	
	04819HRS	



## 04806SFI

SFI  



Three colour available. SFI seat belt, aluminum buckle  
Ideal for off road and boats. 5 fixing point carabiner

COL	CODE	
	04806SFIVDM	
	04806SFINR	
	04806SFIVD	

### PAIRS OF SHOULDER PADS



Pair of pads for 3" harnesses. Made of padded velour.  
NOT FIREPROOF.

COL	CODE	
	01098S3N	
	01098S3A	
	01098S3R	



04502



04501



# RACING STEERING WHEELS



**NEW**  
**F-10 C**

Carbon steering wheel for prototype single-seater and sports vehicle. Ergonomic grip, designed based on experience gained with the racing teams of the most prestigious motor manufacturers. Hole interaxis 3x50.8 mm.

COL	CODE
■	015PC270SSN
Scamosciato - Suede - Ante	

**NEW**  
**F-10 A**

Aluminium steering wheel for prototype single-seater and sports vehicle. Ergonomic grip, designed based on experience gained with the racing teams of the most prestigious motor manufacturers. Hole interaxis 3x50.8 mm.



COL	CODE
■	015P270SSN
Scamosciato - Suede - Ante	

**P 310**

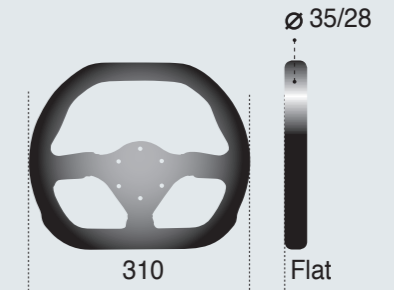

Flat steering wheel ideal for Sports car. Hole interaxis: 6x70 mm.

COL	CODE
■	015P310F2SN
Scamosciato - Suede - Ante	

**P 300**

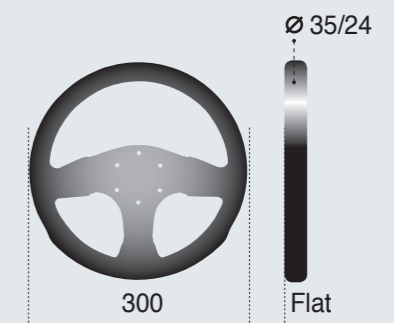

Black anodized spokes. High quality black silicone lining, without any odour. Horn button. Thumb shape on grip. Hole interaxis: 6x70 mm.

COL	CODE
■	015P300SN
Scamosciato - Suede - Ante	



## CARBON 385

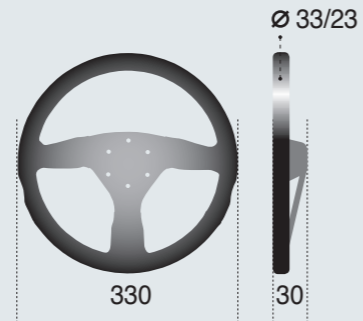

Grip and spokes made of carbon. Only 385 grams. Passed tests for use in Formula One racing and German TÜV against collapse. Hole interaxis: 6x70 mm.

COL	CODE	
■	015RC385SN	
Scamosciato - Suede - Ante		

## DRIFTING SW

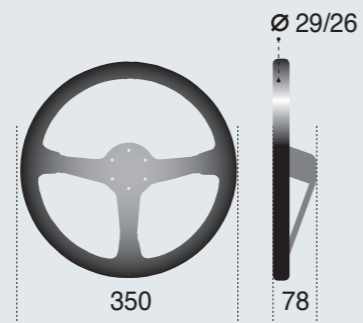

Black anodized spokes. High quality black silicone lining, without any odour. Horn button. Thumb shape on grip. Hole interaxis: 6x70 mm.

COL	CODE	
■	015R350SNR	

## R 353

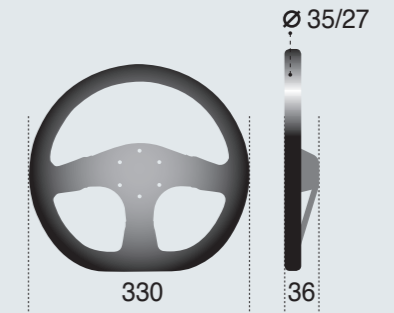

Flat steering wheel with large grip. Hole interaxis: 6x70 mm.

COL	CODE	
■	015R353PSN	
Scamosciato - Suede - Ante		

## R 368

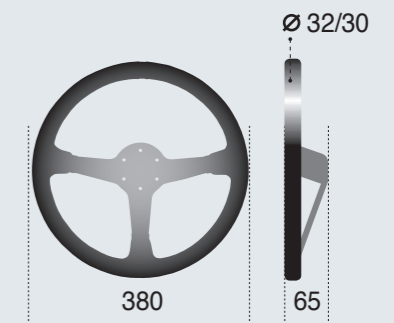

### OFF ROAD SPECIAL DISHED

Dished steering wheel. Ideal on off-road cars. Hole interaxis: 6x70 mm.

COL	CODE	
■	015R368MSN	
Scamosciato - Suede - Ante		



## R 323

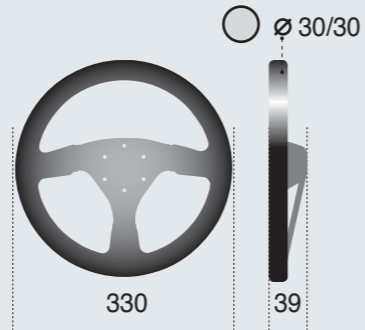

Dished steering wheel with small grip.  
Hole interaxis: 6x70 mm.

COL	CODE
■	015R323PSNR
Scamosciato - Suede - Ante	

## R 333

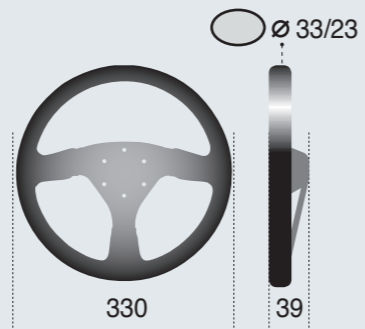

Volante a calice con razze alleggerite.  
Interasse foratura: 6x70 mm.  
Dished steering wheel with lighter spokes.  
Hole interaxis: 6x70 mm.  
Volante en forma de copa con orificios de  
aligeramiento en los radios. Distancia entre  
agujeros: 6x70 mm.

COL	CODE
■	015R333PSNO
Scamosciato - Suede - Ante	



## R 383

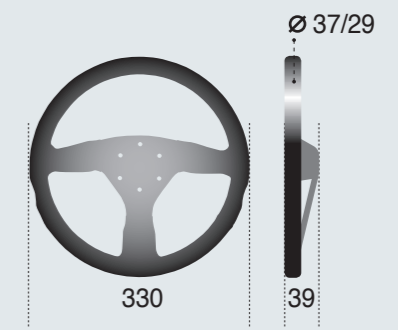

Steering wheel with special comfortable grip  
shape. Hole interaxis: 6x70 mm.

COL	CODE
■	015R383PSN
Scamosciato - Suede - Ante	

## R 375

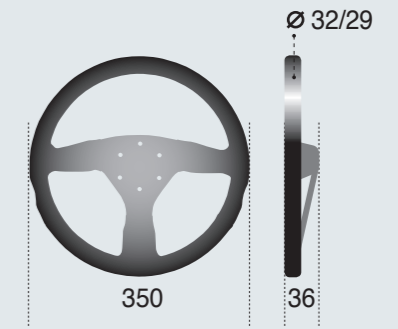

Special 36 mm dished. Hole interaxis: 6x70 mm.

COL	CODE
■	015R375PSN
Scamosciato - Suede - Ante	



## R 345

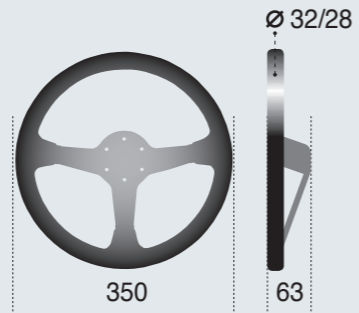

Dished steering wheel with small grip.  
Hole interaxis: 6x70 mm.

COL	CODE
■	015R345MSN
	Scamosciato - Suede - Ante
■	015R345MLN
	Pelle - Leather - Piel

## R 215

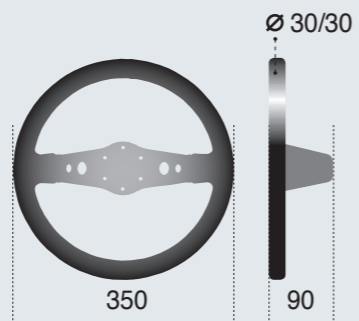

Dished steering wheel with lighter spokes.  
Hole interaxis: 6x70 mm.

COL	CODE
■	015R215CSN
	Scamosciato - Suede - Ante
■	015R215CLN
	Pelle - Leather - Piel

## R 325

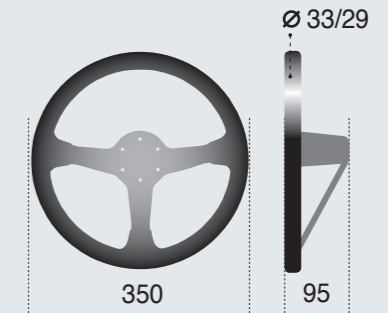

Dished steering wheel with three spokes and small grip. Hole interaxis: 6x70 mm.

COL	CODE
■	015R325CSN
	Scamosciato - Suede - Ante
■	015R325CLN
	Pelle - Leather - Piel

## SANREMO

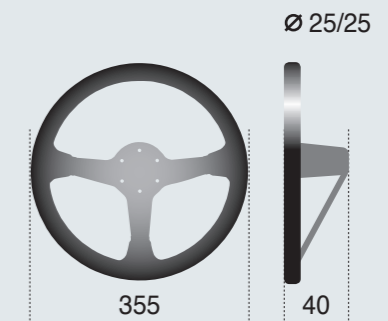

Steering wheel with round grip shape 25/25 mm. Diameter 355 mm. Three-spokes mirror polished. Hand grip in natural mahogany painted. U-ring fixing to the spokes: 9 aluminum rivets.

CODE
015R355VR



### QUICK RELEASE TOURING/RALLY

New quick release aluminium hub with steel steering column, ideal for use in rallies or on the track. Six bolt fastening 70 mm apart on hub side + (3+6) holes on steering wheel. Option of using 6 bolt steering wheel or 3 bolt Sparco. Fixing stud in high resistance steel with double safety lock (one for fixing + one to prevent accidental unfastening).

COL	CODE	
■	015R96NR	



### QUICK RELEASE TRACK/FORMULA

New quick release aluminium hub with steel steering column, ideal for use in formula races. Fitting with steering column to be welded directly to the steering + (3+6) holes on steering wheel side. Option of using 6 bolt steering wheel or 3 bolt Sparco. Fixing stud in high resistance steel with double safety lock (one for fixing + one to prevent accidental unfastening).

COL	CODE	
■	015R95NR	

### MOZZI - HUB

FOR THE COMPLETE APPLICATION LIST  
SEE THE PRICE LIST



### PAD

Steering wheel pad in sponge. Outer diameter 160 mm, height 50 mm, made of suede with Sparco embroidery, full three-strip locking rear buttons (compatible with dishes and flat steering wheels).



COL	CODE	
■	015001	





sparco®

OFFICIAL SUPPLIER OF YOUR PASSION

OFFICIAL SUPPLIER OF YOUR PASSION

OFFICIAL SUPPLIER OF YOUR PASSION



OFFICIAL SUPPLIER OF YOUR PASSION



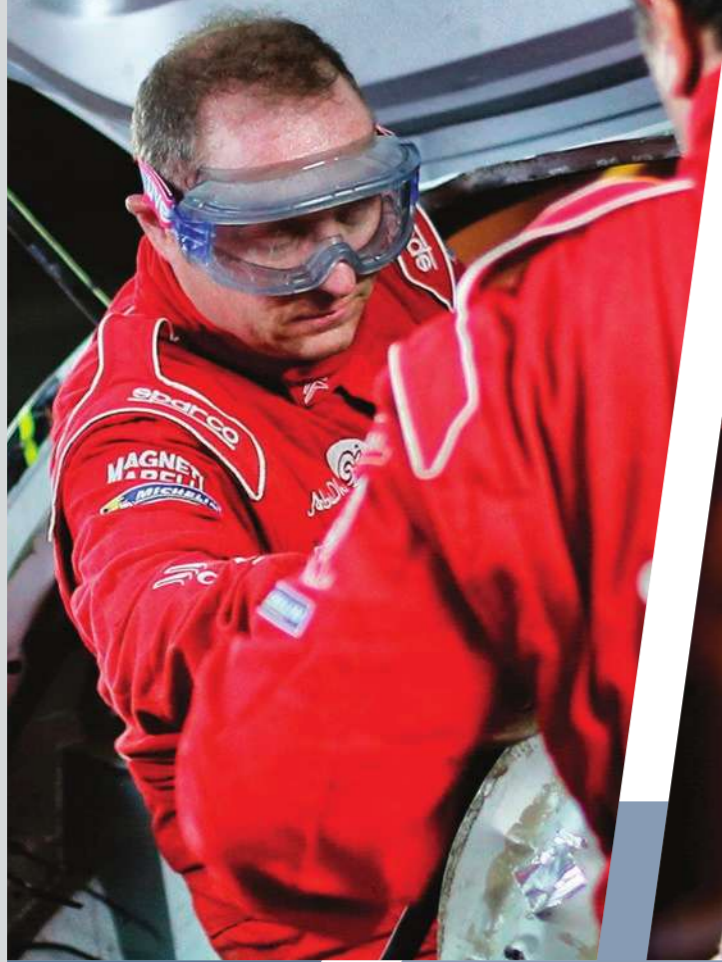

OFFICIAL SUPPLIER OF YOUR PASSION

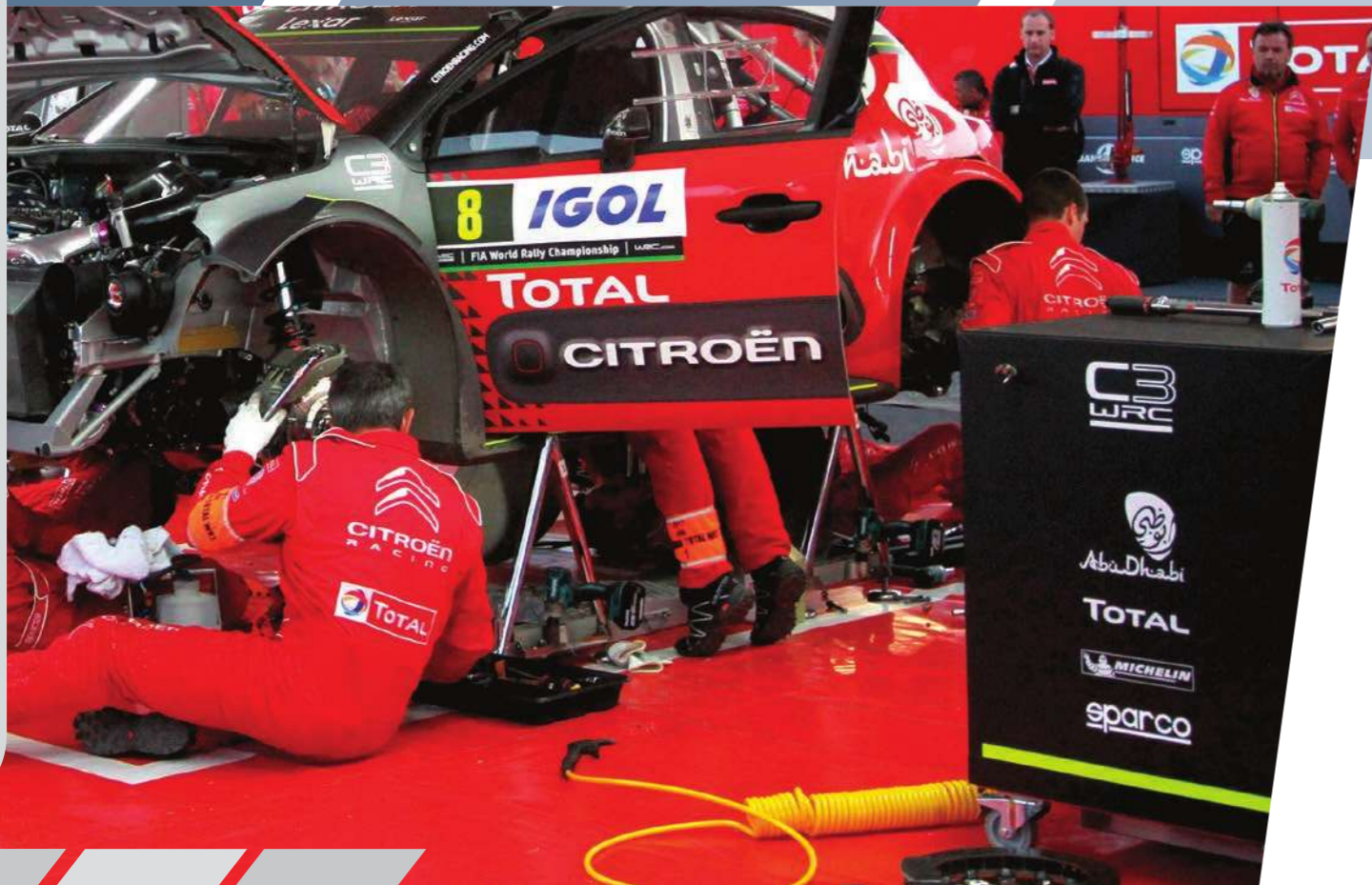

sparco®

OFFICIAL SUPPLIER OF YOUR PASSION

OFFICIAL SUPPLIER OF YOUR PASSION

OFFICIAL SUPPLIER OF YOUR PASSION



OFFICIAL SUPPLIER OF YOUR PASSION

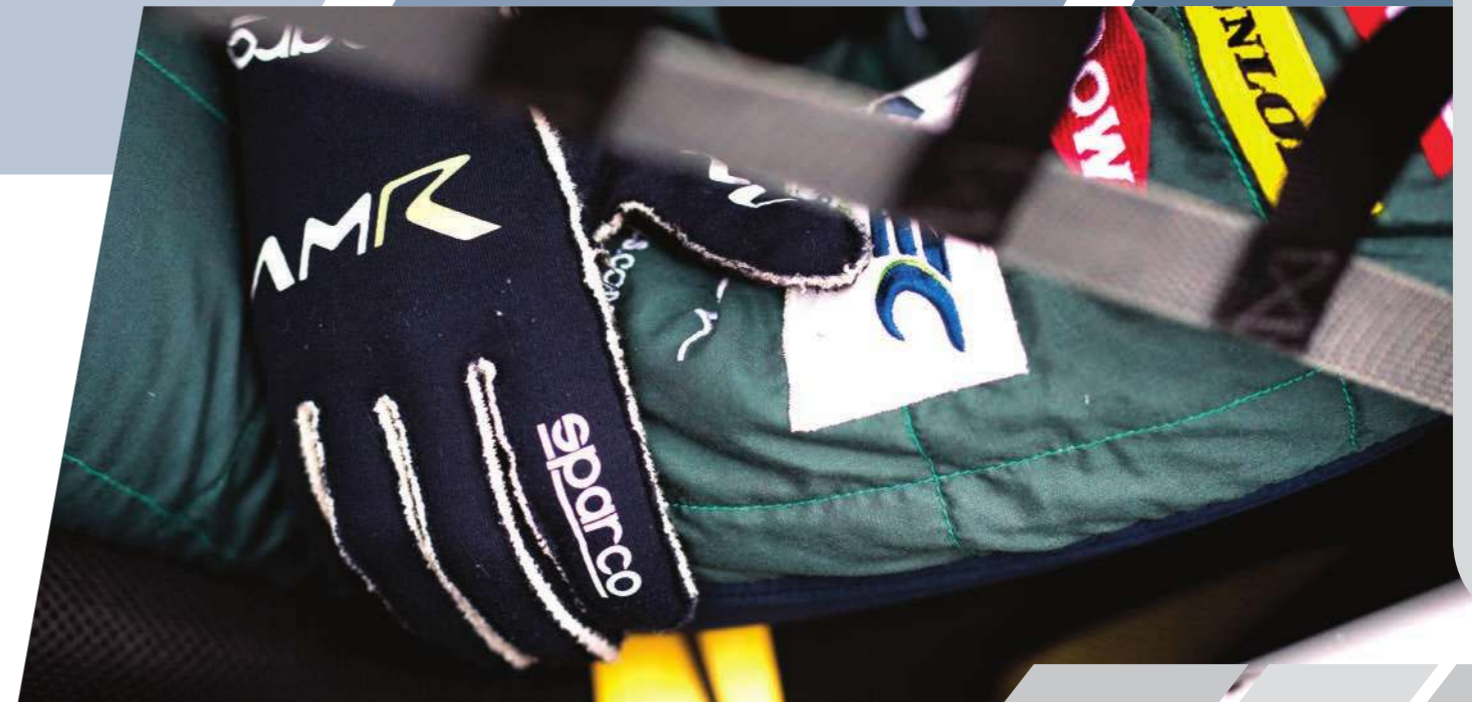

sparco®

OFFICIAL SUPPLIER OF YOUR PASSION



OFFICIAL SUPPLIER OF YOUR PASSION



sparco®

OFFICIAL SUPPLIER OF YOUR PASSION

OFFICIAL SUPPLIER OF YOUR PASSION

OFFICIAL SUPPLIER OF YOUR PASSION



OFFICIAL SUPPLIER OF YOUR PASSION



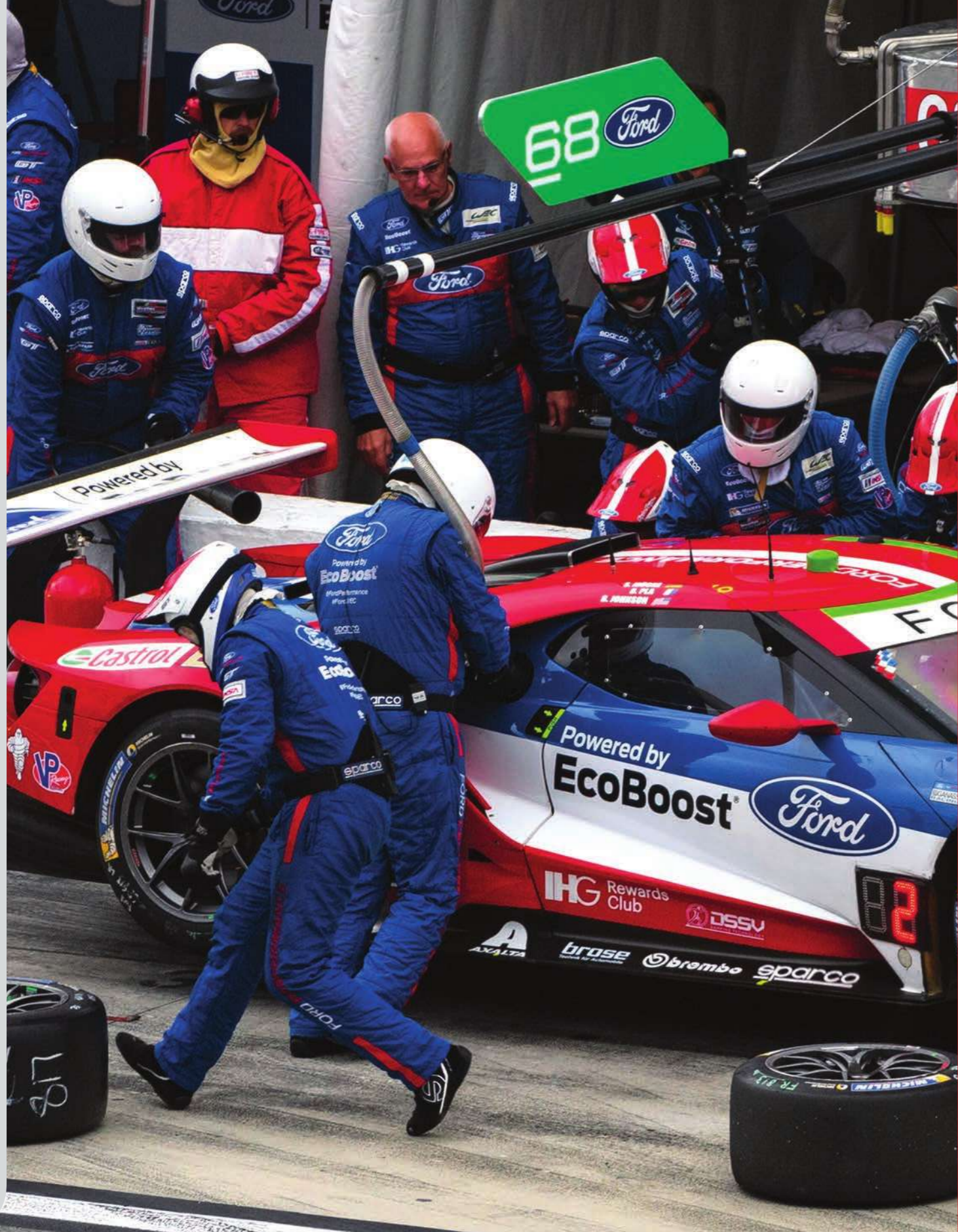

# RACING TECHNICAL

# NEW 01494EANGT

ALUMINIUM

01494EANGT

ELECTRICAL SYSTEM



Suitable for closed cockpit cars the latest Extreme fire extinguisher systems from SPARCO have been developed to be lighter weight and provide rapid extinguishing output resulting in rapid fire out times. Using Novec 1230™ fluid for both cockpit & Engine compartment this is the Lightest two system set currently available anywhere complying with the latest 8865-2015 FIA approval. Using a Patent Pending Nozzle design with only one in the cockpit and one in the engine compartment making for an easier installation. Rapid fire out times, convincingly passing the FIA standard as tested by BSI. Novec™1230 fluid is a Halon replacement with zero ozone depletion, no GWP, leaves no residue and has no effect on delicate electronics, the preferred choice of the environmentally aware driver. The system is supplied as a complete set with the latest power pack (conforming to FIA 8865-2015 regulations), tubing, compression fittings, bulkhead fittings, nozzles, wiring, internal and external switches and E stickers. The system is suitable for petrol and E85 fuel and can be used in vehicles with cockpit volumes from 1.4m<sup>3</sup> to 2.3m<sup>3</sup>.

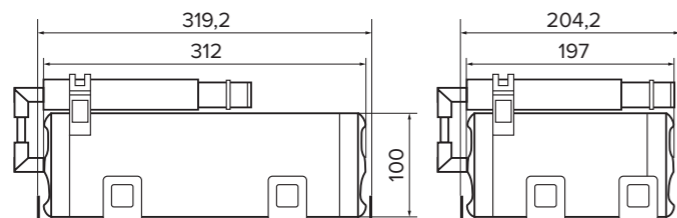

Bottle plinth

MA0141040



Bottle plinth

MA0141041



Bolted Straps

MA0141039



Cockpit nozzles / Engine nozzles

MA0141032



Extension Pipe

MA0141035



Bulkhead Adapter + M20 nut

MA0141033



10 mm 1/4" BSP Compression Fitting

MA0141034



12,7 mm 1/4" BSP Compression Fitting

MA0141037



10mm Copper pipe L=200 cm

MA0141031



12,7 mm Copper pipe L=50 cm

MA0141036



Hirschman Plug & Leads L=?

MA0141005



Power Pack Hirschman Type

MA0141030



External Fire Button

MA0141008



Internal Fire Button

MA0141007



E Location Sticker Small

MA0141020

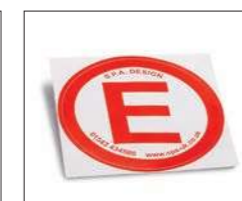

E Location Sticker Large

MA0141011

**NEW**  
**01494EAN**

ALUMINIUM

01494EAN

IMPIANTO ELETTRICO  
ELECTRICAL SYSTEM  
EQUIPO MANDO ELÉCTRICO



MANUFACTURER: SPA Desing  
MODEL: XTREME-X  
HOM. NO: EX.007.16  
FIA STANDARD: 8865-2015

Suitable for closed cockpit cars the latest Extreme fire extinguisher systems from SPARCO have been developed to be lighter weight and provide rapid extinguishing output resulting in rapid fire out times. Using Novec 1230™ fluid for both cockpit & Engine compartment this is the Lightest two system set currently available anywhere complying with the latest 8865-2015 FIA approval. Using a Patent Pending Nozzle design with only one in the cockpit and one in the engine compartment making for an easier installation. Rapid fire out times, convincingly passing the FIA standard as tested by BSI. Novec™1230 fluid is a Halon replacement with zero ozone depletion, no GWP, leaves no residue and has no effect on delicate electronics, the preferred choice of the environmentally aware driver. The system is supplied as a complete set with the latest power pack (conforming to FIA 8865-2015 regulations), tubing, compression fittings, bulkhead fittings, nozzles, wiring, internal and external switches and E stickers. The system is suitable for petrol and E85 fuel and can be used in vehicles with cockpit volumes from 2.3 m<sup>3</sup> to 4.1 m<sup>3</sup>.

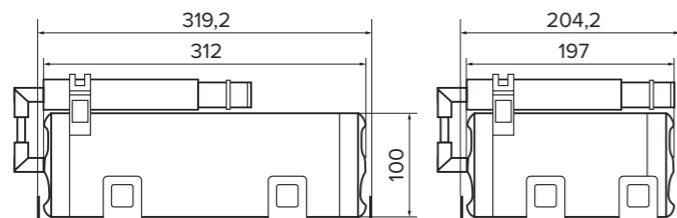

Bottle plinth

MA0141040



Bottle plinth

MA0141041



Bolted Straps

MA0141039



Cockpit nozzles / Engine nozzles

MA0141032



Extension Pipe

MA0141035



Bulkhead Adapter + M20 nut

MA0141033



10 mm 1/4" BSP Compression Fitting

MA0141034



12,7 mm 1/4" BSP Compression Fitting

MA0141037



10mm Copper pipe L=200 cm

MA0141031



12,7 mm Copper pipe L=50 cm

MA0141036



Hirschman Plug & Leads L=??

MA0141005



Power Pack Hirschman Type

MA0141030



External Fire Button

MA0141008



Internal Fire Button

MA0141007



E Location Sticker Small

MA0141020



E Location Sticker Large

MA0141011



**NEW**  
**01496EAL**

ALUMINIUM

01496EAL

ELECTRICAL SYSTEM



MANUFACTURER: SPA Desing  
MODEL: Fire Sense Response  
HOM. NO: EX.003.98  
FIA STANDARD: FIA 2000

This electrically operated Multi-Flo extinguisher system is designed specifically for saloon race and rally closed cockpit cars.  
The 4.0 Litre capacity foam based extinguishing is dispensed evenly to both the engine bay and cockpit via 4 specially designed nozzles to give fast knock down and fire out times. The kit supplied offers all parts needed to fit and operate.  
Kit Includes -  
• 4.0 Litre Single Chamber Bottle  
• Mounting Bracket & Straps  
• 1 x Power Pack  
• 2 x Plug & Cable Assembly  
• 1 x Cockpit Switch  
• 1 x Waterproof External Switch  
• 4 x Nozzles  
• Tubing  
• T Connectors  
• Decals  
• Instruction manual



6" Mounting Brackets

MA0141021



6 mm Nozzle

MA0141015



6 mm T-piece

MA0141009



6 mm Bulkhead

MA0141014



6 mm Dekabon Hose (5 m)

MA0141010



Power pack

MA0141006



Hirschman Leads (5 m)

MA0141005



External Fire Button

MA0141008



Internal Fire Button

MA0141007



E Location Sticker Small

MA0141020

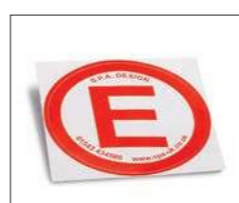

E Location Sticker Large

MA0141011



Antitorpedo Bracket

MA0141038

**NEW**  
**01496MAL**

ALUMINIUM

01496MAL

MECHANICAL SYSTEM



MANUFACTURER: SPA Desing  
MODEL: Fire Sense Response  
HOM. NO: EX.003.98  
FIA STANDARD: FIA 2000

This mechanically operated Multi-Flo extinguisher system is designed specifically for saloon race and rally closed cockpit cars.

The 4.0 Liter capacity foam based extinguishing is dispensed evenly to both the engine bay and cockpit via 4 specially designed nozzles to give fast knock down and fire out times.

The kit supplied offers all parts needed to fit and operate.

Kit Include:

- 4.0 Litre Single Chamber Bottle
- Mounting Bracket & Straps
- 2 x Pull Cables
- 4 x Nozzles
- Tubing
- T Connectors
- Decals
- Instruction manual

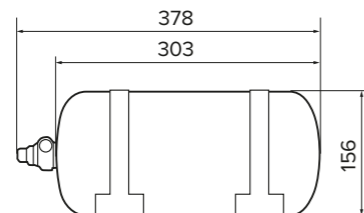

0,6x500



6" Mounting Brackets

MA0141021



6 mm Nozzle

MA0141015



6 mm T-piece

MA0141009



6 mm Bulkhead

MA0141014



6 mm Dekabon Hose

MA0141010



6 Foot Pull Cable

MA0141012



12 Foot Pull Cable

MA0141013



Cable Adjuster

MA0141018



Solderless Cable Nipple

MA0141019



E Location Sticker Small

MA0141020



E Location Sticker Large

MA0141011

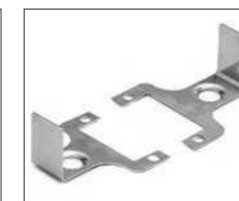

Antitorpedo Bracket

MA0141038

**NEW**  
**01496MSL**

STEEL

01496MSL

MECHANICAL SYSTEM



MANUFACTURER: SPA Desing  
MODEL: Fire Sense Response  
HOM. NO: EX.003.98  
FIA STANDARD: FIA 2000

This mechanically operated Multi-Flo extinguisher system is designed specifically for saloon race and rally closed cockpit cars where weight saving is not an issue.

The 4.0 Litre capacity foam based extinguishant is dispensed evenly to both the engine bay and cockpit via 4 specially designed nozzles to give fast knock down and fire out times.

The kit supplied offers all parts needed to fit and operate.

Kit Includes:

- 4.0 Litre Single Chamber Steel Bottle
- Mounting Bracket & Straps
- 2 x Pull Cables
- 4 x Nozzles
- Tubing
- T Connectors
- Decals
- Instruction Manual

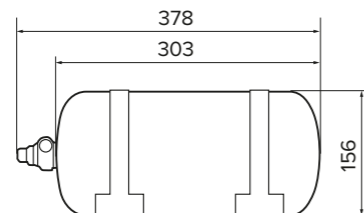

0,6x500



6" Mounting Brackets

MA0141021



6 mm Nozzle

MA0141015



6 mm T-piece

MA0141009



6 mm Bulkhead

MA0141014



6 mm Dekabon Hose (5 m)

MA0141010



6 Foot Pull Cable

MA0141012



12 Foot Pull Cable

MA0141013



Cable Adjuster

MA0141018



Solderless Cable Nipple

MA0141019



E Location Sticker Small

MA0141020



E Location Sticker Large

MA0141011



Antitorpedo Bracket

MA0141038

**NEW**  
**01491EAN**  
(ON DEMAND)

ALUMINIUM

01491EAN

ELECTRICAL SYSTEM



MANUFACTURER: SPA Desing  
MODEL: EXTREME 2.5  
HOM. NO: EX.003.98  
FIA STANDARD: FIA 2000

Extreme is a new environmentally friendly gas fire extinguisher system which uses 3M's Novec 1230, a halon gas replacement with zero ozone depletion and is non toxic. A further bonus with the Novec 1230 gas is that it leaves no residue and has no adverse effect on delicate electrical components. Specifically designed for use in closed cockpit cars the 2.5Kg Extreme system utilizes multi directional nozzles to provide fire knockdown and fire out properties in record times. The easy to fit, compact system is supplied with all components needed to install and operate. Suitable for use with Petrol, Diesel and Bio fuel.



0,6x450

0,8x250

1,0x100

1,2x50

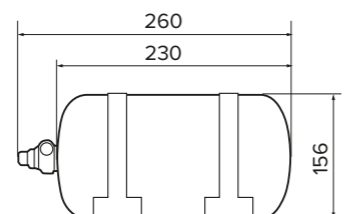

6" Mounting Brackets

MA0141021



Power pack

MA0141006



Hirschman Leads (5 m)

MA0141005



Internal Fire Button

MA0141007



External Fire Button

MA0141008



6 mm Dekabon Hose (4,5 m)

MA0141010



8 mm Dekabon Hose (2,5 m)

MA0141016



10 mm Dekabon Hose (1 m)

MA0141017



12 mm Dekabon Hose (0,5 m)

MA0141022



8 mm-6 mm Y piece

MA0141025



10 mm-8 mm Y piece

MA0141024



12 mm-10 mm Y piece

MA0141023



10 mm Bulkhead fitting

MA0141026



10 mm - 8 mm reducer

MA0141027



Novec Engine Bay Nozzles

MA0141028



Novec Cockpit Nozzles

MA0141029



E Location Sticker Small

MA0141020



E Location Sticker Large

MA0141011



Antitorpedo Bracket

MA0141038

**NEW**  
**01493EAN**  
(ON DEMAND)

ALUMINIUM

01493EAN

ON DEMAND

ELECTRICAL SYSTEM



MANUFACTURER: SPA Desing  
MODEL: SPAEX-1.8-APS  
HOM. NO: EX.040.16  
FIA STANDARD: FIA 2000

Suitable for both closed and open cockpit cars the Extreme gas fire suppression system utilizes a single 1.8kg gas unit which has been developed using brand new advanced propulsion technology.

This technology results in rapid suppressant delivery which provides much faster fire out times than previously achieved. Using specially designed multi directional nozzles impressive results are achieved in fire knockdown and fire out in saloon or single seater cars.

SPARCO Extreme Gas system uses Novec 1250, a next generation Halon replacement which is highly effective yet is environmentally friendly (Zero ozone depletion and non toxic). Recommended for petrol, bio fuels and diesel fuels it has the added benefit of leaving no residue and has no adverse effect on vehicle electrics.



0,6x450

0,8x250

1,0x100

1,2x50

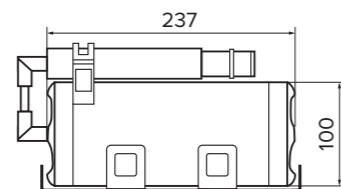

6" Mounting Brackets

MA0141048



Power pack

MA0141006



Hirschman Leads (5 m)

MA0141005



Internal Fire Button

MA0141007



External Fire Button

MA0141008



6 mm Dekabon Hose (4,5 m)

MA0141010



8 mm Dekabon Hose (2,5 m)

MA0141016



10 mm Dekabon Hose (1 m)

MA0141017



12 mm Dekabon Hose (0,5 m)

MA0141022



8 mm-6 mm Y piece

MA0141025



10 mm-8 mm Y piece

MA0141024



12 mm-10 mm Y piece

MA0141023



10 mm Bulkhead fitting

MA0141026



10 mm - 8 mm reducer

MA0141027



Novec Engine Bay Nozzles

MA0141028



Novec Cockpit Nozzles

MA0141029



E Location Sticker Small

MA0141020



Location Sticker Large

MA0141011



Antitorpedo Bracket

MA01481

**NEW**  
**01496BAL**

STEEL

01496BAL



- FIA And MSA Approved
- Used In Rally Cars
- Lightweight
- 2.40 Litre Capacity
- Foam Based Extinguishant
- Complete With Mounting Bracket
- Dimensions - 440mm Long x 210mm Diameter

**NEW**  
**01492BCL (ON DEMAND)**

CARBON

01492BCL



Mounting Brackets

MA0141046



Hand Held replacment valve

MA0141045



Mounting frame

MA0141047

**NEW**  
**01497BSP6**

STEEL

01497BSP6



- Designed for use in BOX / GARAGE / PIT LANE
- 6.00 Litre Capacity
- Foam Based Extinguishant
- Complete With Mounting Bracket

**0144PB21**

STEEL

01496MSL



- Hand-held extinguisher 2.0 Kg, powder complies EN3 comes with two brackets.



# ROLL BAR

Sparco's range of roll bars has been developed over the years in collaboration with leading manufacturers and with official teams. The roll bars are designed using CAD software, and then subjected to simulations and physical tests in accredited laboratories. All the Sparco roll bars comply with Article 253.8 of Annex J to the FIA Yearbook, and with the rules introduced on 01/01/2003. The Sparco roll bars are made of cold drawn seamless pipes in E255 (Fe45) or 25CrMo4 (for most roll bars approved by ASN).

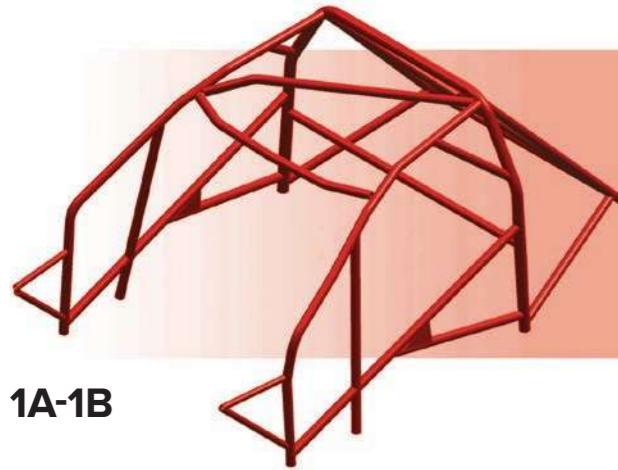

1A-1B

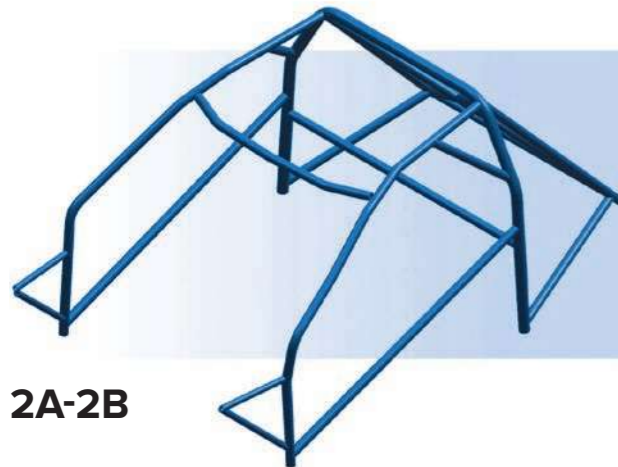

2A-2B

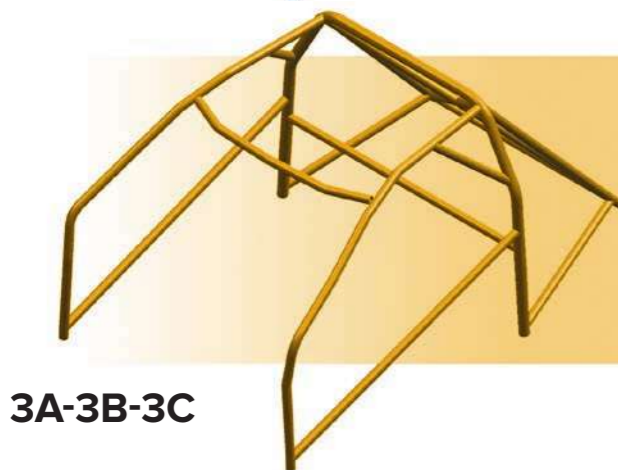

3A-3B-3C

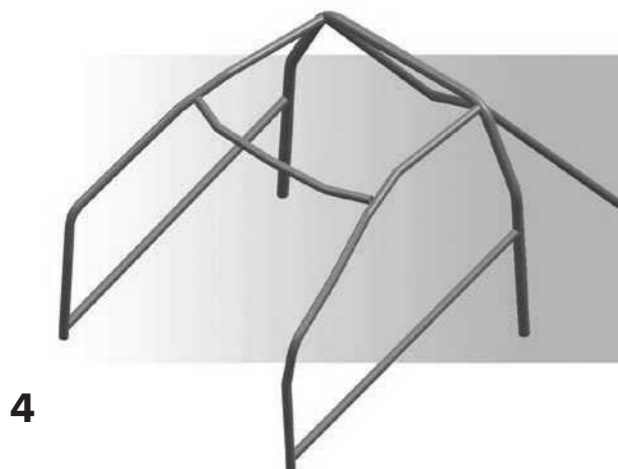

4

**FEATURES**

Passage adhering to the body shell wherever possible. Accurate manufacturing. Specific boxed reinforcements. Made with certified material. Front suspension fixing points on some models.

- 1A Multipoint welded-in, 25CrMo4 with front suspension fixing points.
- 1B Multipoint welded-in, Fe45 with front suspension fixing points.
- 2A Multipoint built-in, 25CrMo4 with front suspension fixing points.
- 2B Multipoint built-in, Fe45 with front suspension fixing points.
- 3A 25CrMo4 roll cage without front suspension fixing points.
- 3B Fe45 roll cage without front suspension fixing points.
- 3C Weld-in roll cage without front suspension point.
- 4 Roll cages with door bars. Fe 45

FOR THE COMPLETE APPLICATION LIST PLEASE CHECK PRICE LIST

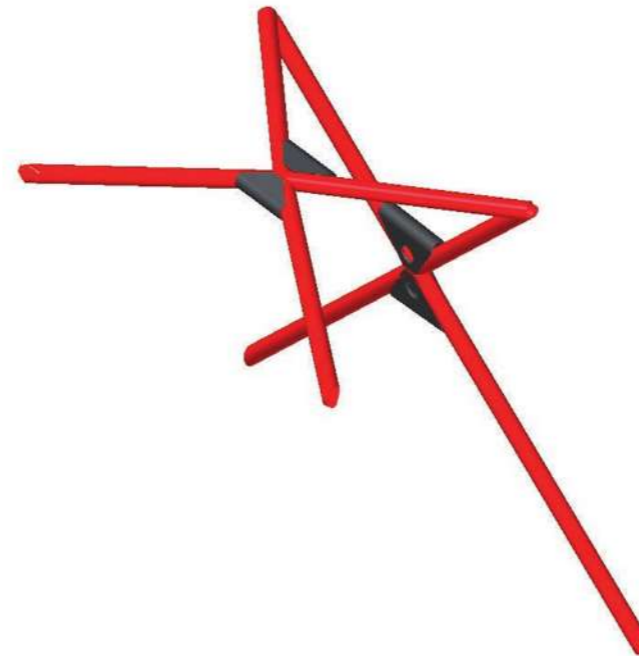

**ROLL BAR PADDINGS**

As from 01.01.2003 FIA-approved padding has become compulsory in all types of races and cars, Sparco supplies a material certified in accordance with FIA regulation 8857-2001, in different choices of length and diameter. The paddings are fitted to the roll cages in all possible points of contact with driver with harnesses fastened.

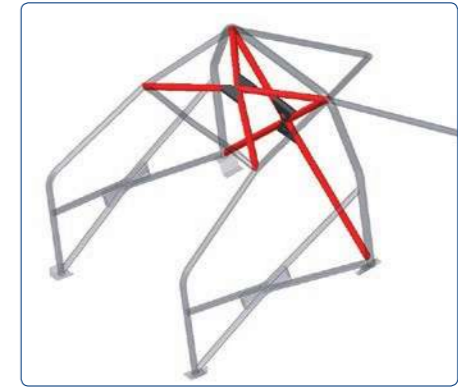

**RACING START ADAPTATION KIT**

Racing start kit is proposed to upgrade the existing Appendix J roll cages. This kit is composed of 6 tubes to build up the cross reinforcement for the roof and the main roll bar, complete with reinforcement gussets.

CODE	00780KS
------	---------



0076050	Ø 50 mm - 500 mm - 122 g - Set 2 pcs
---------	--------------------------------------



0076045	Ø 45 mm - 500 mm - 131 g - Set 2 pcs
---------	--------------------------------------



0076040	Ø 40 mm - 500 mm - 129 g - Set 2 pcs
---------	--------------------------------------



0076035	Ø 40 mm - 500 mm - 135 g - Set 2 pcs
---------	--------------------------------------



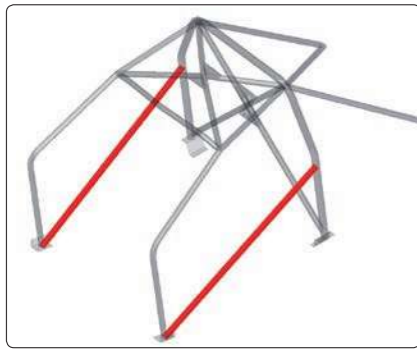

00797

**DOOR BARS KIT**

Universal kit composed of 2 x door bars (diam. 40 x 2 mm) with 2 x welded plugs on one side, 4 x M10 screws, 4 x M10 self-locking bolts, 4 x forks, 2 x plugs.



00798SP1

**UNIVERSAL GUSSET KIT FOR ROOF OR MAIN ROLL BAR CROSS REINFORCEMENT**

kit composed of 2 x universal reinforcement gussets to be mounted on the tubes' cross joint (dimensions 190 x 85 mm). This is a universal kit so it's could be necessary for the user to adapt it to his own roll cage.



00798SP2

**UNIVERSAL GUSSET KIT FOR DOORBAR CROSS**

kit composed of 4 x universal reinforcement gussets to be mounted on the tubes' cross joint (dimensions 100 x 170 mm). This is a universal kit so it's could be necessary for the user to adapt it to his own roll cage.



0078140S	(Ø 40 mm)
0078150S	(Ø 50 mm)

**ROLL CAGE FORK**

fork for tubes' assembly, using plug + fork system (tube diameter 40 mm) (tube diameter 50 mm).



00780M

**ROLL CAGE PLUGS -**

Pair of perforated sleeves (diameter 45 mm) for tubes' assembly.



00782NTS

**ROLL CAGE PLUG -**

forged plug for tubes' assembly, using plug + fork system.

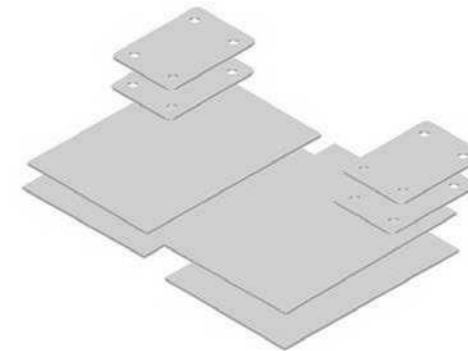

00780P

**REINFORCEMENT PLATES + COUNTERPLATES FIA 2010 UPDATING KIT**

kit composed of 4 x perforated plates + 4 x flat counter plates (3 mm thick). These plates must be adapted in according to the different configurations of roll cages or body shells and allow to update the roll cage fixing in accordance with 2010 FIA regulation.

**SUBARU IMPREZA STI**

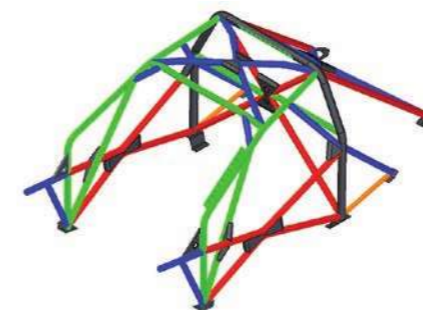

**SEAT LEON CUPRA**

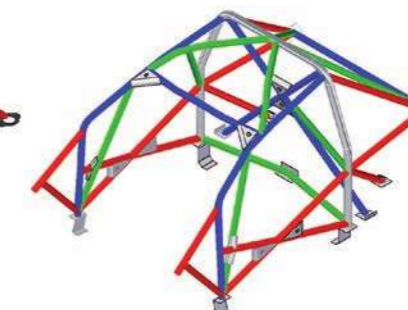

**MITSUBISHI EVO VIII**

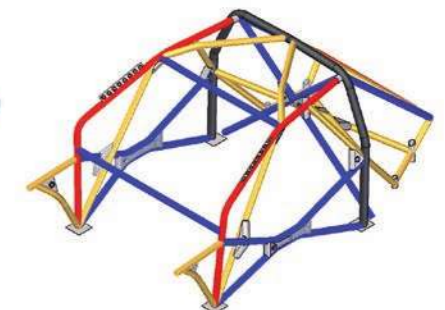

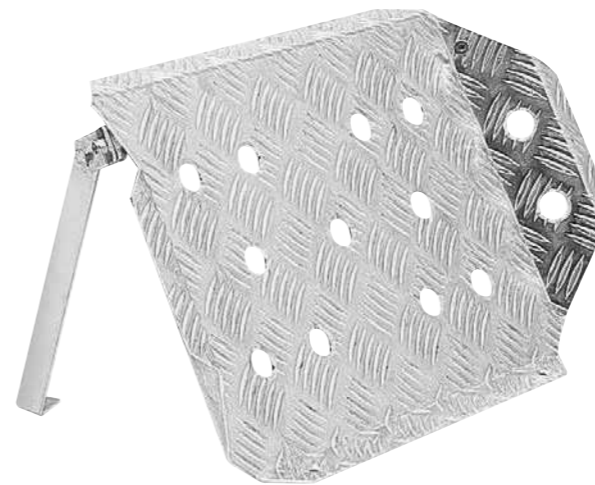

## NAVIGA

5 mm anodized aluminium sheet, laser cutted. Pre drilled for easy fitting on the floor, or on the MAT floor, adjustable angle; dimensions about cm 36 x 28. High quality materials.

COL	CODE	
■	03789TAN	

## MATT

5 mm anodized aluminium sheet, laser cutted. Pre drilled for easy fitting dimensions about cm 50 x 38. High quality materials.

COL	CODE	
■	03789RAN	

## CO-DRIVER FOOTREST

Footrest collapsible in the event of a crash. Embossed anodised aluminium.

COL	CODE	
■	03789AN	

## DRIVER FOOTRESTS



Embossed anodised aluminium complete with brackets, bolts and screws.

COL	CODE
■	03780AN

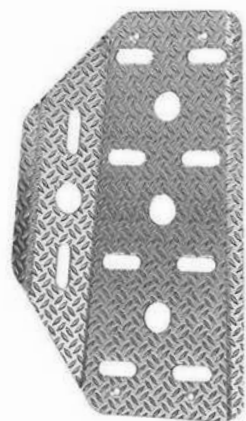

In embossed anodised aluminium.

COL	CODE
■	03778AN (until stock last)



Driver footrest in shiny aluminium.

COL	CODE
■	03788BRI

## PEDAL SETS



Acciaio. Colore nero - Steel. Black - Acero. Color Negro

COL	CODE
■	03775



3-piece set in embossed anodised aluminium, complete with brackets, bolts and screws.

COL	CODE
■	03779AN



## CARBON

3-piece set in pre-bent and shaped mixed carbon. Brake and clutch with non-slip inserts.

COL	CODE
■	03783L

## BONNET PINS



01606S	01606AA	01606AR	01608

01606S - Pair of stainless steel bonnet pins with captive slide pin.

01606A - Pair of aluminium bonnet pins, anodised blue or red with captive slide pin.

01608 - Pair of stainless steel spring hooks.

## SPACERS

FOR THE COMPLETE APPLICATION LIST PLEASE CHECK PRICE LIST.



## AERO FUEL CAPS



Oss. Argento. Silver-Oss. Plata  
Senza chiave. Without key. Sin llave.

COL	CODE
■	270050A

Oss. Argento. Silver-Oss. Plata  
Con chiave. With key. Con llave.

COL	CODE
■	270040A



COL	CODE
■	27009G

## STUDBOLTS

Together with nuts to allow replacement of original bolts. Necessary for fitting wheel spacers. Available in various lengths and thread sizes. Machined from solid 10.9 steel by rolling, with special anti-wear treatment. **NUTS** Available in different sizes. Machined from 6.6 zinc plated steel.

MUD FLAPS



Curved polyethylene mud guards kit thickness 1,5 mm not FIA compliant.

COL	CODE
■	03791RS
■	03791AZ
■	03791NR
■	03791



TYRE WARMERS

CODE	CODE
29354	29354 Centralina controllo digitale 4 uscite
293605721D	5721D Kit 4 term.regol.digitale GR.N. 190/215 575/580
293505721	5721T Kit 4 term.regol.termost. GR.N. 190/215 575/580
293606126D	6126D Kit 4 term.regol.digitale Super 2000 230/255 600/620
293506126	6126T Kit 4 term.regol.termost. Super 2000 230/255 600/620
293606222D	6222D Kit 4 term.regol.digitale GR.A.T. 190/215 635/640
293506222	6222T Kit 4 term.regol.termost. GR.A.T. 190/215 635/650
293606524D	6524D Kit 4 term.regol.digitale GR.A.A. 230/255 635/650
293506524	6524T Kit 4 term.regol.termost. GR.A.A. 230/255 635/650
293606527D	6527D Kit 2 term.regol.digitale DTM 260/285 655/670
293606527L	6527T Kit 2 term.regol.termost. DTM 260/285 655/670
293606931D	6931D Kit 2 term.regol.digitale DTM 295/325 695/710
293606931L	6931T Kit 2 term.regol.termost. DTM 295/325 695/710



FIA APPROVED  
Pair of red plates, very sturdy.

COL	CODE	
■	03794RS	285 x 500 x 4 mm



HAMMERS

Professional hammer with light and seatbelt cutter built-in.

01615	
-------	--

Hammer with seatbelt cutter built-in.

01613	
-------	--

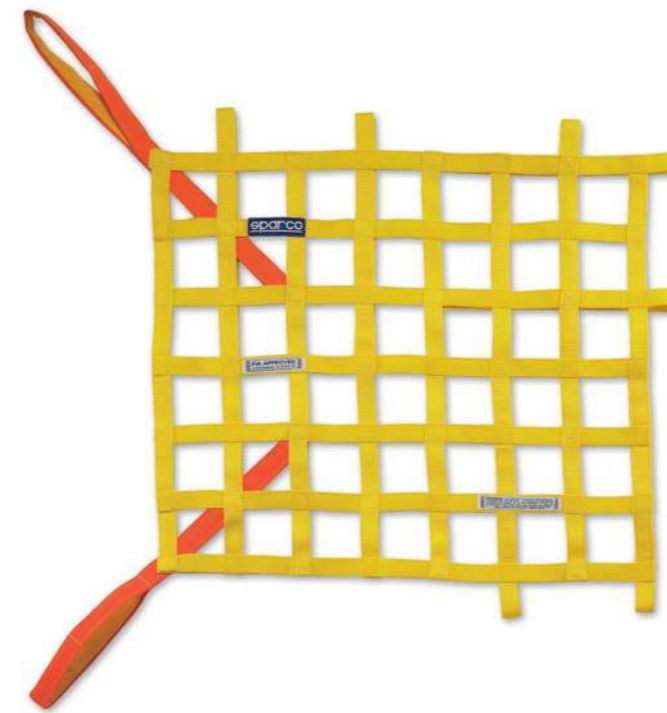

MANUFACTURER: SPARCO  
MODEL: 002193NR  
HOM. NO: RN.008.16  
FIA STANDARD: 8863-2013

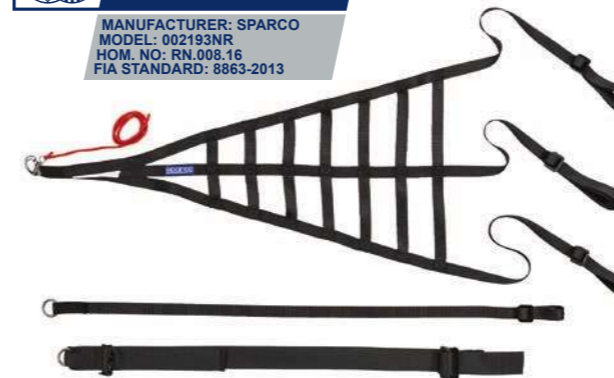

COL	CODE
■	002193NR



MANUFACTURER: SPARCO  
MODEL: 002194NR  
HOM. NO: RN.011.17  
FIA STANDARD: 8863-2013

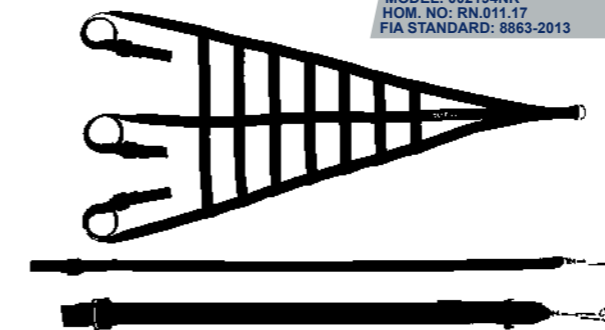

COL	CODE
■	002194NR

WINDOW NETS

Approved in compliance with FIA 2003 spec.  
Dimensions: 50 cm long and 52 cm high.  
Velcro tape for quick fastening to roll bar.

COL	CODE
■	002192FA-R
■	002192FA-G
■	002192FA-BM

FIA 8863-2013 APPROVED WINDOW NET SPECIFICALLY FOR TRACK USE

Seat side fixing with 1" belts and 2 bar adjusters for fixing to rollbar  
Dashboard side fixing with optional double use:

- Quick release fixing with 1" strap
- Quick release fixing 2" strap and spring-operated adjuster for better net tension .

## PIT SIGNAL BOARD



4 row reflection-proof black aluminium frame.

CODE		
00594	Pit signal kit	



## SC-505

5 memory lap or split timing modes - 1/100 sec precision for 24 hours - automatic lap counter to 99 1st-5th places - button confirm beep.

CODE		
00550003BM		



CODE		
00594C	Cover	
00592/1	Number sets	
00594T	Pit board	



## TEMPO

Professional product for rally use - Chronometer and time calculator - Comparison of your time and that of 30 competitors. Precision: 0.01 sec - Time functions: total, partial, countdown - with acoustic alarm, classification - PC connection to download data - Weight: 115 g. Dimensions: 72 x 105 x 26.

CODE		
00557CS03		



## MAPLIGHTS

Led Reading lamp, length 49 cm, flexible tube, 12 V.

CODE		
01628		

## TYRE PRESSURE GAUGES



Ø 63 mm  
Scale 0 - 4 bar, aluminium handle, rubber cap, high-precision recording.

CODE		
2941463		



Ø 100 mm  
Scale 0 - 4 bar, aluminium handle, rubber cap, high-precision recording.

CODE		
29424101C		

## NOTE PAD

CODE		
03724		

## BATTERY MASTER SWITCH



Battery master switch with rotating lever. Instant disconnection of all electric circuits. Provision for remote control. Complies with FIA spec. Suitable for 6, 12 and 24V systems, rated at 100A continuous.

CODE	01337	
------	-------	--



Bipolar master battery cutout switch with rotating lever. Instant disconnection of master electric circuit. Provision for remote control. Suitable for 6, 12 and 24V systems, rated at 100A continuous.

CODE	01336	
------	-------	--

## RACERS TAPE



01691..

01692

0169550

All-purpose heavy duty racer tape. Roll 50 mm wide x 50 metres. 7 different colours.

CODE	01691	
------	-------	--

Aluminised tape. Roll 50 mm wide x 50 m.

CODE	01692	
------	-------	--

Transparent, scratchproof adhesive tape. Roll 50 mm wide x 50 m.

CODE	0169550	
------	---------	--



Universal spare wheel fastening with high-strength tape, complete with locking ratchet, 3 eyebolts and 3 fixing plates.

CODE	03773	
------	-------	--

## TOWING EYE



Ribbon towing eye. Hole diameter 15 mm, MAX load 3000 kg.

CODE	01612RS	
------	---------	--



Steel towing eye. Hole diameter 50 mm, FIA compliant.

CODE	01626GI	
------	---------	--



Steel towing eye. Hole diameter 80 mm, FIA compliant.

CODE	01627GI	
------	---------	--



Fissaggio chiave a croce con molle di tenuta e gomma antivibrante. Cross spanner fastening with retainer springs and anti-vibration rubber. Fijación de llave en cruz con resortes de retención y goma anti-vibración.

CODE	03776	
------	-------	--





# RACING MECHANICS

MS-D



**NEW**  
**MS-D TOP**  
**MS-D BOTTOM**

FIA 8867-2017	Size: S-XXXL	
360/390 g/m <sup>2</sup>	2 Layers	

**COMPOSITION:** Meta-Aramid, two-layer sandwich.  
**CHARACTERISTICS:** The first suit, jacket and trousers, designed with characteristics that are indispensable in terms of materials and modelling, ensuring maximum protection for mechanics and refuelling personnel and for handling inflammable liquids/fuels out of "race time", all in compliance with the specific FIA 8867/2016 regulation. Provided with all the typical characteristics of racing suits (armholes, elasticised back pad, light fabric mesh) these are the perfect transposition of our classic models, suitable for the new regulations.  
**PERSONALISATION:** fireproof transfer printing - embroidery.



002013JNR..

002013PNR..

VAT NOT INCLUDED

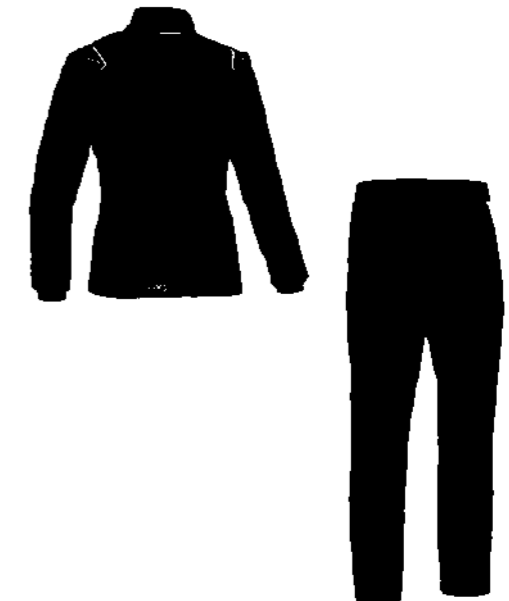



MS-7



## NEW MS-7

Size: S-XXL		
250/300 g/m <sup>2</sup>	1 Layer	

**COMPOSITION:** Polyester/Nylon/Cotton.  
**CHARACTERISTICS:** High-range mechanic's suit, made by batching a main structure in mixed polyester/cotton fabric, with panels partly nylon-padded and in high-resistance and anti-abrasion Cordura. Ankles with adjustable closure with zip, perforated elasticised panels on the armhole allowing greater mobility and breathability. Cordura panels on the forearm and legs, precisely, below the knee with padding to improve comfort when seated; Elasticised underarm panels and generous elasticised panel on the back, both completely perforated for greater mobility and breathability. Light welt pouches with zip fastener, large pockets with bellows on the legs with closing flaps and smartphone pocket, jeans-type pockets; pen-holder pockets applied on the sleeves. Hooks for application of a radio on the rear belt; cable-holes on the back at belt height. Preformed neck and belt.  
**PERSONALISATION:** transfer printing - embroidery.



002016NR..

002016BM..

VAT NOT INCLUDED



MS-3



## NEW MS-3

Size: S-XXL		
230/250 g/m <sup>2</sup>	1 Layer	

**CHARACTERISTICS:** Low-range mechanic's suit made of light and comfortable polyester/cotton mixed fabric, the right economy compromise. The suit has been designed for dual-use with the typical workwear market in mind as well as the specific market, for indoor Kart or rental. Comfort and size identification have therefore been optimised and designed for this double use. Adjustable ankle closure with Velcro, pockets on the legs and sleeves. Pen-holder pocket with indication of size. Adjustable wrist cuffs with Velcro. Breast pocket with zip.

**PERSONALISATION:** transfer printing - embroidery.



002015RS..

002015AZ..

002015GR..

002015NR..



**DUNGAREES**

Overall with pockets on front and sides.

SIZE	COL	CODE
S-XXL		0020011AZ..
		0020011NR..

**WORK APRON**

Overall with pockets on front and sides.

SIZE	COL	CODE
SINGLE SIZE		00215N

**MANTELLA  
RAIN CLOAK • CHUBASQUERO 3/4**

SIZE	CODE
S/M - L/XL - XXL	002398..

**PIT STOP**

Pit stop helmet with CE. Removable chin guard. Air intakes on forehead and on sides. Rear hook for fixing the mask. Strap with micrometric adjustment. Inner breathable lining. Very light. Not fireproof. Available in grey colour only.

SIZE	COL	CODE
S-XL		003339..
EN 1077-07 CE		

**TIDE MG-9**

Pit stop helmet with CE approval for skiing. Removable chin guard. Air intakes on forehead and on sides. Rear hook for fixing the mask. Strap with micrometric adjustment. Inner breathable lining. Very light. Not fireproof. Available in grey colour only.

SIZE	COL	CODE
8-12		001303..NR
FIA 8856-2000	HTX	

GUANTI DA LAVORO  
WORK GLOVES • GUANTES DE TRABAJO



Meta-aramid gloves. Protective glove, knitted fabric with knit cuff and PVC non-slip palm. 100% meta-aramid.

SIZE	COL	CODE
SINGLE SIZE	<input type="checkbox"/>	00210LNX



Knitted fabric glove with elastic wristband. 100% para-aramid on the outside, cotton lining inside.

SIZE	COL	CODE
SINGLE SIZE	<input type="checkbox"/>	00205



### MECA III

The backs of Meca-3 gloves are made from elasticised, printed, scuff resistant fabric. The palms are in synthetic, scuff resistant hide and there are reinforcements positioned between the thumb and index finger. Pads between the fingers provide better breathing. Velcro belt for tighter fitting.

SIZE	COL	CODE
S-XL	<input type="checkbox"/>	002093RS
	<input type="checkbox"/>	002093AZ
	<input type="checkbox"/>	002093NR



Rubber grip on palms. Cotton.

SIZE	COL	CODE
SINGLE SIZE	<input type="checkbox"/>	00207
	<input type="checkbox"/>	00207NR



### MX-RACE

Two types of mesh: high breathability and texture quadrilateral mesh with honeycomb structure. Reinforcements and heel leather texture-red. Internal lacing system with ribbon loops. Anatomic pre-shaped inner sole. Antistatic VIBRAM sole in EVA, oil and hydrocarbons resistant. FEATURES: Lightweight and breathable. High grip and shock absorber VIBRAM sole for maximum comfort and low stress. Laces in 2 different colours are provided with the package.

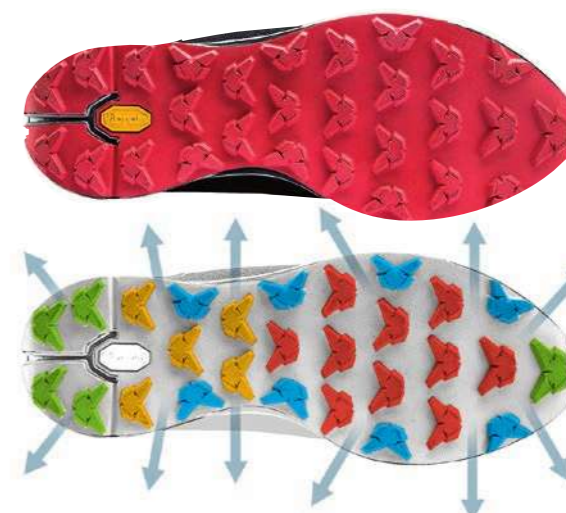

- GRIP
- TRACTION
- BRAKING
- CUSHIONING
- STABILITY
- SELF-CLEANING

SIZE
39-48



001216..NR

001216..NRNR

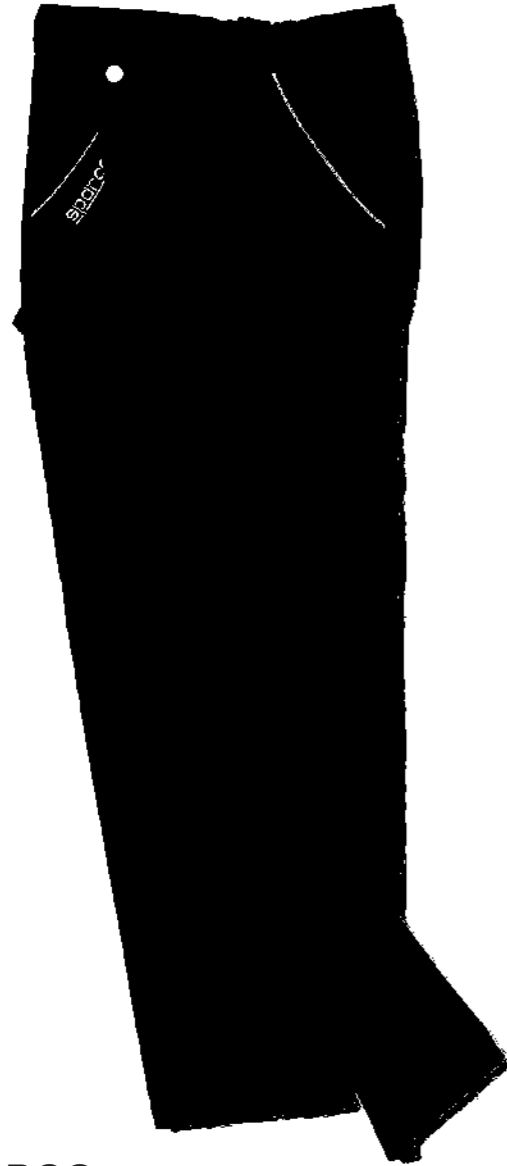

## CARGO

**COMPOSITION:** 35% Cotton 65% polyester 210 g/m<sup>2</sup> **FEATURES:** Wear resistant fabric, lightweight and breathable. Lateral and back pockets with velcro closure. Tools hooks on the front and on the back. Elastic on waist and specific construction adding fitting. It is possible to personalize this items with colours, printings and embroideries (Sparco guideline).

SIZE	COL	CODE	
XS-XXL	■	011496NR..	■



## TOOL BAG MOCHILA

Backpack with internal tool holder. Practical outside pockets.

SIZE	COL	CODE	
SINGLE SIZE	■	01644NGR	



## TOOLS BELT

Radio belts, adjustable.

SIZE	CIRCUMFERENCE	CODE	
M-L	min 90 - max 120 cm	016451ML	
L-XL	min 120 - max 150 cm	016451LXL	

# sparco®

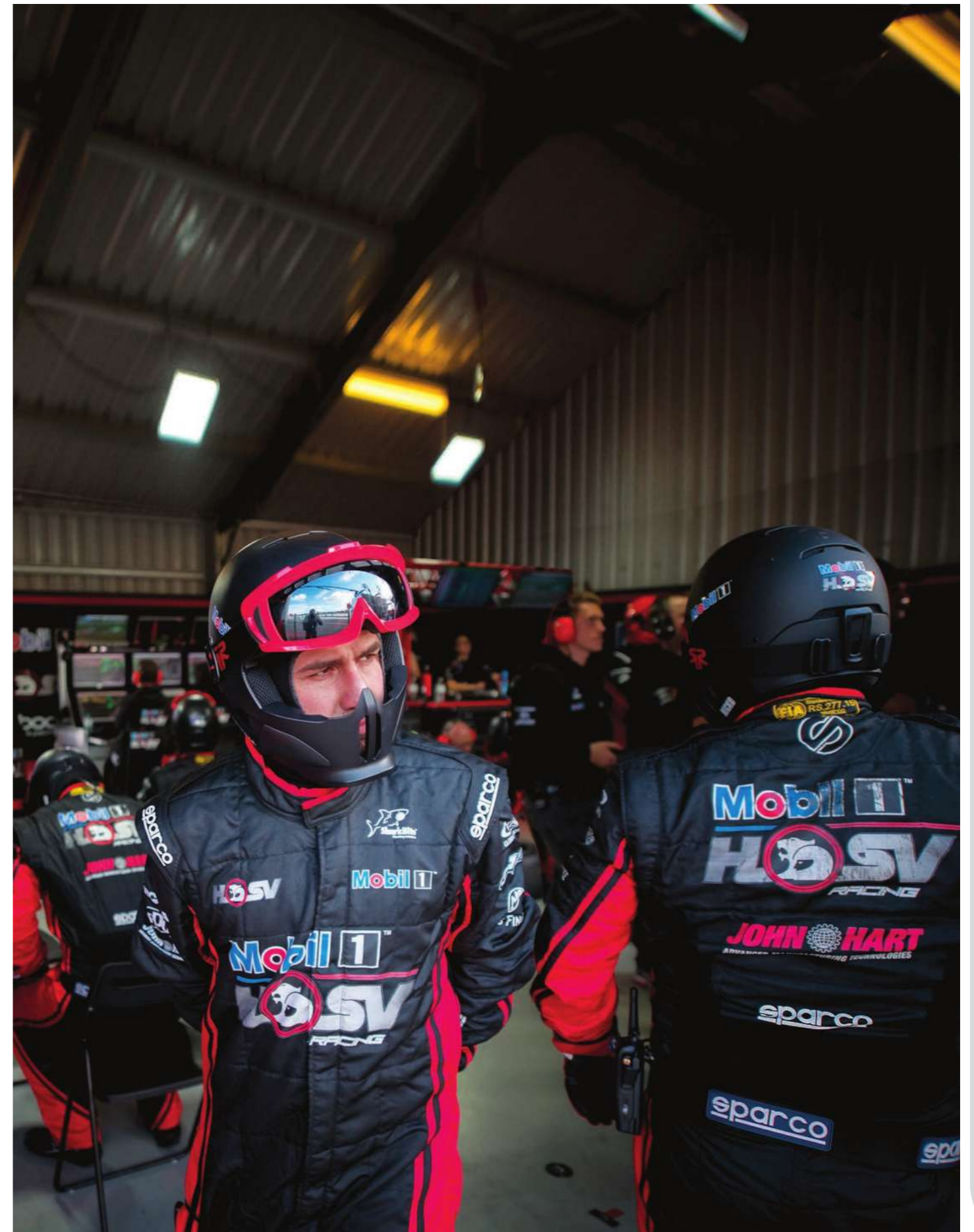

sparco®

OFFICIAL SUPPLIER OF YOUR PASSION

OFFICIAL SUPPLIER OF YOUR PASSION

OFFICIAL SUPPLIER OF YOUR PASSION



OFFICIAL SUPPLIER OF YOUR PASSION

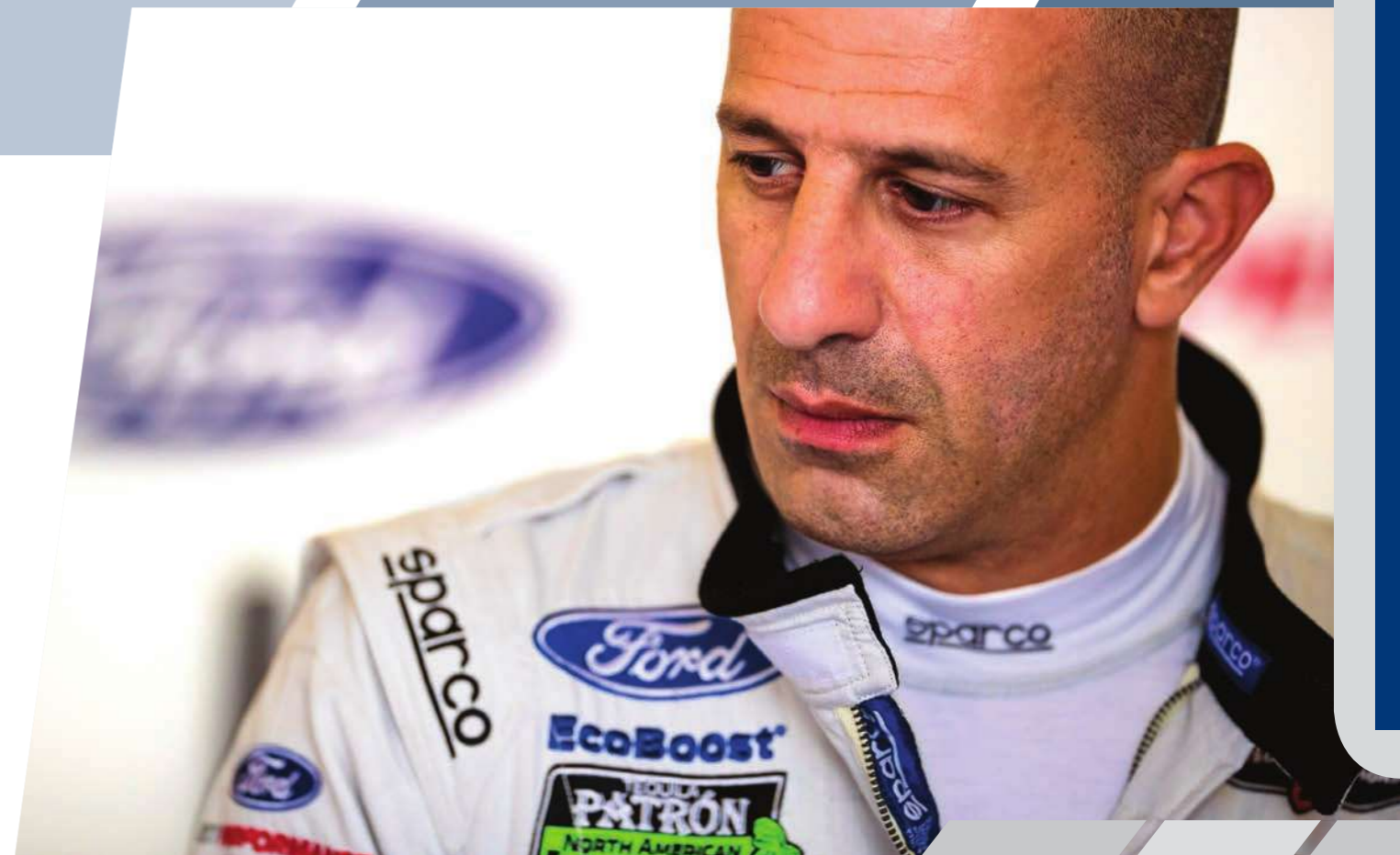

sparco®

OFFICIAL SUPPLIER OF YOUR PASSION

OFFICIAL SUPPLIER OF YOUR PASSION

OFFICIAL SUPPLIER OF YOUR PASSION



OFFICIAL SUPPLIER OF YOUR PASSION



sparco®

OFFICIAL SUPPLIER OF YOUR PASSION



OFFICIAL SUPPLIER OF YOUR PASSION





sparco®

OFFICIAL SUPPLIER OF YOUR PASSION

OFFICIAL SUPPLIER OF YOUR PASSION

OFFICIAL SUPPLIER OF YOUR PASSION



OFFICIAL SUPPLIER OF YOUR PASSION



# KARTING SUITS

OWN THE  
PASSION



PRIME KS-10



PRIME KS-10

CIK-FIA N2013.1	CE [E]	
2 Layers	Size: 44-62	
440/460 g/m <sup>2</sup>	Kid Size: 120-150	

The Prime KS-10 kart suit was specifically designed to be fully personalised using prints while at the same time offering the driver light weight, comfort and breathability.

**COMPOSITION:** Polyester/Polyamide. Two-layer sandwich with overall weight of about 440/460 g/m<sup>2</sup>.

**CHARACTERISTICS:** The Prime KS-10 suit has two layers with elasticised panels at the armpits and back. Perforated panels at the back, armpits, inner leg and outer thigh allow the suit to breathe and thus minimise the condensation of sweat and improve comfort. Ribbed neck and concealed zip. Pockets and classic belt. The suit can be fully personalised with prints. Cordura® back protection which increases resistance to wear and tear at the points in most contact with the kart seat.



MANUFACTURER: SPARCO  
MODEL: K38 PRIME KS-10  
HOM. NO: CIK-FIA 2013/023  
FIA STANDARD: N 2013-1



002306..AZ

002306..NR

\* VAT NOT INCLUDED \*



## X-LIGHT KS-7



## X-LIGHT KS-7

CIK-FIA N2013.1	CE [2]	
2 Layers	Size: 44-62	
380/400 g/m <sup>2</sup>	Kid Size: 120-150	

The X-Light KS-7 kart suit is made from a new generation polyester fabric with excellent resistance properties.

**COMPOSITION:** Polyester/Polyamide. Two-layer sandwich with overall weight of about 380/400 g/m<sup>2</sup>.

**CHARACTERISTICS:** The X-Light KS-7 suit has two layers and complete armholes. Back panel and large elasticised knee inserts to increase comfort. Elasticised perforated panels at the armpits, inner leg and outer thigh allow the suit to breathe and thus minimise the condensation of sweat and improve comfort. Covered zip and lightened neck with perforated inner surface. Pockets and classic belt. Preformed sleeves.



MANUFACTURER: SPARCO  
MODEL: K41 X-LIGHT KS-7  
HOM. NO: CIK-FIA 2013/023  
FIA STANDARD: N 2013-1



002336..GRSCE

002336..BIVD

002336..AZRS

002336..NRGRS



ROBUR KS-5



ROBUR KS-5

CIK-FIA N2013.1	CE [E]	
2 Layers	Size: XS-XXL	
480/500 g/m <sup>2</sup>		

**COMPOSITION:** Polyamide Cordura®. Two-layer sandwich with overall weight of about 480/500 g/m<sup>2</sup>.

**CHARACTERISTICS:** The ROBUR KS-5 suit has two layers, and complete armholes with a large elasticised back panel to improve comfort. There are perforated high resistance Cordura® inserts at the sides and bottom. Elasticised perforated panels at the armpits, inner leg and outer thigh allow the suit to breathe and thus minimise the condensation of sweat and improve comfort. The whole neck area can breathe thanks to the use of both the perforated materials used in making the suit. Concealed zip, pockets and classic belt. Preformed sleeves.



MANUFACTURER: SPARCO  
MODEL: K40 ROBUR KS-5  
HOM. NO: CIK-FIA 2013/023  
FIA STANDARD: N 2013-1



• VAT NOT INCLUDED •

002335..Aafb

002335..BgSR

002335..GSGB

002335..NGSB



# GROOVE KS-3



## GROOVE KS-3

CIK-FIA N2013.1	CE [L]	
2 Layers	Size: XS-XXL	
500/540 g/m <sup>2</sup>	Kid Size: 120-150	

The GROOVE KS-3 kart suit is made from Cordura® fabric.  
**COMPOSITION:** Polyamide Cordura®. Two-layer sandwich with overall weight of about 500/540 g/m<sup>2</sup>.  
**CHARACTERISTICS:** The GROOVE KS-3 suit has two layers, complete armholes and an elasticised back panel. Elasticised perforated panels at the armpits, inner leg allow the suit to breathe and thus minimise the condensation of sweat and improve comfort. Ribbed neck, concealed zip, pockets and classic belt. Prefor-med sleeves.



MANUFACTURER: SPARCO  
 MODEL: K39 GROOVE KS-3  
 HOM. NO: CIK-FIA 2013/023  
 FIA STANDARD: N 2013-1



002334..RSBI 002334..AZBI 002334..SINR 002334..GRSGF 002334..GRSVD 002334..NRSI 002334..NRCE



\* VAT NOT INCLUDED \*

# TRACK KS-1

2 Layers    Size: XS-XXL



The Track KS-1 kart suit was designed for use in races where CIK-FIA approval is not required.  
**COMPOSITION:** Polyamide/Polyester. Two-layer sandwich; 250 g/m<sup>2</sup>.  
**CHARACTERISTICS:** The Spring KS-1 suit has two layers with a light, resistant outer fabric and a breathable, perforated inner lining. The suit also features floating sleeves and perforated, elasticised air inlets in the inner leg, back and underarm areas. The lighter, lower neck is made with a perforated lining to improve the suit's breathing properties. Patch pockets and concealed zip.

002337..SI    002337..NR



# INDOOR K-1 (TILL STOCK LAST)

1 Layers    Size: S-XXL



SUIT DEVELOPED FOR RENTAL Size/height label stitched on shoulder for quick identification. Open pockets. Velcro strips on upper chest and legs for rapid fit.



002325AZ1S    002325AZ2M    002325AZ3L



002325AZ4XL    002325AZ5XXL



Size: S-XXL

Kid Size: 120-130 / 140-150



00239T..

## KARTING RAINWEAR

Made of transparent material that doesn't become yellow.



CRW &gt; PAGE 290

## KARTING OVERSHOES

Karting overshoes in Neoprene, Velcro closure system with gusset and natural rubber sole.

**COMPOSITION:** 100% Neoprene with external fabric in 80% Nylon + 20% Spandex. Natural rubber sole.

SIZE	CODE
S-XL	002432..N
S (36-38) - M (39-41) - L (42-44) - XL (45-47)	



SIZE	CODE
S-XL	002431..N
S (38,5-40) - M (40-41,5) - L (41,5-43) - XL (43,5-45)	

MANTELLA  
RAIN CLOAK • CHUBASQUERO 3/4

SIZE	CODE
S/M - L/XL - XXL	002398..

MANICOTTO ANTICALORE  
ALUMINIZED SLEEVES • MANGUITO ANTICALORIn materiale alluminizzato. Applicabile su qualsiasi tuta.  
Made from aluminumized material. Suitable for any karting suit.  
Realizado en material aluminizado. Aplicable con cualquier mono.

CODE
00240





## SEAMLESS

X-COOL  
SILVER

The new racewear for kart drivers features a twin polyester/polypropylene structure to offer maximum comfort and water repellent properties. The new racewear is made by means of a processing method known as "body-size" in which the garment is produced as a single piece item with no stitching at the sides. This type of process means different sections can be made more or less elastic to meet differing needs. The existence of more elastic sections makes the garment more comfortable to wear.

**COMPOSITION:** 50% polyester - 50% Polypropylene.  
Average weight of fabric 150/180 g/m<sup>2</sup>



Long-sleeved vest with low neckline. Differentiated mesh structure to provide better comfort and enhance breathability in different specific areas. The raglan sleeve pattern makes the garment more comfortable thanks to the fact that the stitching for the sleeves is positioned in an area that is subjected to less pressure. The wrists and waist have finer stitching for increased comfort.

SIZE	COL	CODE
XS/S - M/L - XL/XXL	<input type="checkbox"/>	002284MBI...



Short-sleeved T-shirt with low neckline. Differentiated mesh structure to provide better comfort and enhance breathability in different specific areas. The raglan sleeve pattern makes the garment more comfortable thanks to the fact that the stitching for the sleeves is positioned in an area that is subjected to less pressure. The wrists and waist have finer stitching for increased comfort.

SIZE	COL	CODE
XS/S - M/L - XL/XXL	<input type="checkbox"/>	002285TBI...



Single layer balaclava with minimal ultra-thin, flat stitching. Differentiated structure with elasticised panels for maximum comfort. Flat eye holes for increased comfort.

SIZE	COL	CODE
SINGLE SIZE	<input type="checkbox"/>	002286BI



Variable textures and increased thickness at the contact points. Cool-max® thread.

SIZE	COL	CODE
XS - S - L - XXL	<input type="checkbox"/>	002271BICE..



Simply add to your washing machine before washing overalls or underwear and the original X-Cool treatment is recharged. Treats one racesuit or 1 set of underwear (pant, top and socks).

001157RECHARGE

**COMPOSITION:** Coolmax /Poliestere. **CHARACTERISTICS:** Flat seams thanks to the use of the extra thin thread. Two different technologies have been used: thin and stretch Jersey 100%Coolmax; double perfo-rated to increase breathability. Jersey parts are treated with X-cool silver for a fresh feeling also with high temperatures, antibacterial effect. Shirt and T-Shirts, slim fit, designed to be comfortable in a driving position. Balaclava single opening.



Cuciture extra piatte.  
Extra flat seams.  
Costuras extra planas.

SIZE	COL	CODE
SINGLE SIZE	☐	002231B
	■	002231N



SIZE	COL	CODE
XS - XL	☐	00224B
	■	00224N



SIZE	COL	CODE
XS - XL	☐	00226B
	■	00226N



COL	CODE
■	00154KN

Ginocchiere. Knee pads. Rodilleras



COL	CODE
■	00155EN

Gomitiere. Elbow pads. Coderas

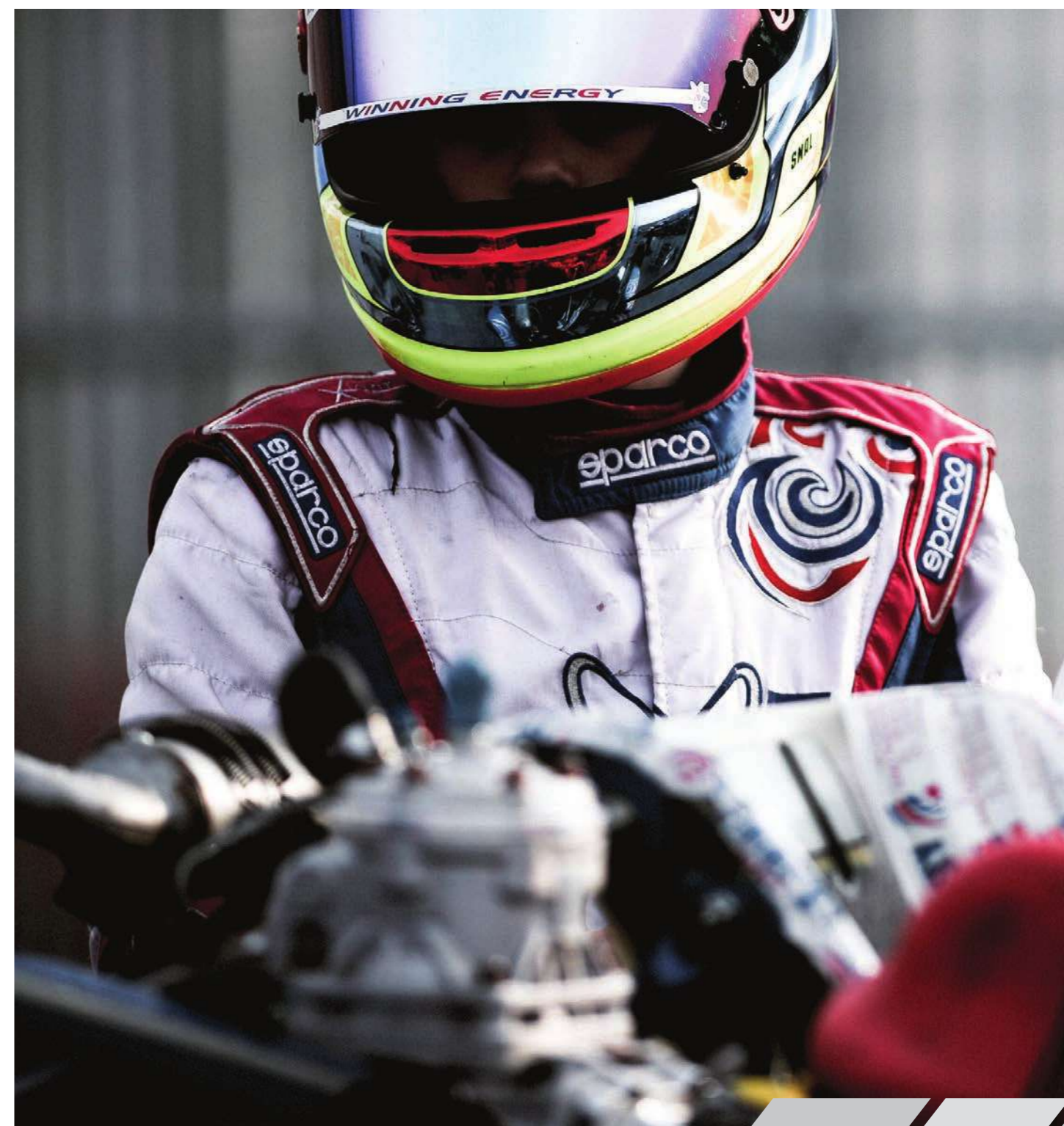

## RIB PROTECTORS



▶ **NEW** • IL CARBONIO

▶ **NEW** • RIB PRO K-7

▶ **NEW** • SJ PRO K-3

**SPK-7**

Semi-rigid rib vest. 100% polyester fabric. Rigid internal structure and polyethylene lining (50%). Material in EVA (50%). Perfect fitting thanks to elastic bands between all protection zones. The border is cover with fabric to avoid tears of the overall.

SIZE	CODE
XXS - XL	002411... (Till stock last)

**SPK-3**

Semi-rigid rib protection vest. 100% polyester. High impact absorbing inner lining, 100% EVA with internal rigid structure. Optimum comfort, reduced thickness.

SIZE	CODE
0 - 3	002412NR... (Till stock last)

sparco®





KIDS ARTICLES



PRIME KS-10  
> PAGE 258



X-LIGHT KS-7  
> PAGE 260



GROOVE KS-3  
> PAGE 264



T-1  
> PAGE 268



ARROW KG-7.1 > PAGE 287



TRACK KG-3 > PAGE 289



CRW > PAGE 290



GAMMA KB-4 > PAGE 283



SPK-3 > PAGE 274



> PAGE 297

ARTICLES FOR RENTING KART



INDOOR K-1 > PAGE 267



CLUB J-1 > PAGE 110



CLUB X-1 > PAGE 103



MECA 3 > PAGE 244



Balaclava 100% cotton.

COL	CODE	
<input type="checkbox"/>	00222ZBSIX	



# KARTING SHOES



## SUPERLEGGERA KB-10



Superleggera KB-10 kart boots offer a high-tech solution from innovation and materials. **COMPOSITION:** the Superleggera KB-10 uppers are made from a breathable pressed fabric with scuff resistant injected moulded TPU. The TPU is injection moulded on the fabric to avoid the use of stitching. Leather reinforcements. Heel protector in padded scuff resistant 3D material. Internal laces. Insoles. Superleggera KB-10.1 racing boots have an elasticised panel at the rear just above the heel to improve fit and allow the ankle to move freely when driving. Light asymmetrical soles with integrated external reinforcement for the area most affected by wear from using the pedals.



001256...NRRS



001256...NRBI



# OMEGA KB-6



Size: 36-48

Omega KB-6 kart boots offer light weight and excellent breathing properties.

**COMPOSITION:** Omega KB-6 uppers are made from a breathable pressed fabric and have leather inserts. Breathable inner lining. Anatomical insoles. They have an elasticised panel at the rear just above the heel to improve fit and allow the ankle to move freely when driving. New asymmetrical rubber soles with external lateral reinforcement. Belt closing with loop.



001257...NRSI



001257...BISI



001257...RSNR



001257...RSVD



001257...AZSI



# GAMMA KB-4



Size: 36-48

Kid Size: 26-34

Gamma KB-4 kart boots are highly resistant and breathable thanks to the use of microfibre fabric.

**COMPOSITION:** the 3D synthetic microfibre fabric is highly wear resistant and breathable. Breathable inner lining. Anatomical insoles with impact absorption area at the heel. The soles on Gamma KB-4 boots are asymmetrical and were designed to reinforce the outer sides of the toes and the inner rear area which are used as pivot zones when driving.



001259...RSBI



001259...NRCE



001259...AZAF



001259...NRNR



001259...NRGF



# KARTING GLOVES





# TIDE KG-9

HTX     Size: 7-12

Gloves with external seams and preformed high-grip and shock-absorber ergonomic palm. Possibility of customisation according to Sparco guidelines.

**COMPOSITION:** External fabric in PA with Cotton lining. Palm with 3D "Volcano" HTX reinforcements (Sparco patent).



00256..RS



00256..AZ





00256..NR



00256..BI



# NEW ARROW KG-7.1 EVO

  Size: 7-12  
Kid Size: 4-6 (Black only)

**CHARACTERISTICS:** Pre-curved. Single-layer fabric on the back and forks, breathable, lighter. Back and fingers preformed, elastic wrist. Ergonomic profiling. Unique and FR patented technology: Touch Sensitive on index and thumb. Palm made of double-layer fabric with single-colour front Palm with new printed graphic using HTX technology, padding in the carpal region of the palm to reduce impact damage. New back graphic for ready-personalisation

**PERSONALISATION:** transfer print.



002554..AZ



002554..BI



002554..NR



002554..RS

**TOUCH-S**



# MOTION KG-5



Size: 7-13

Touch-screen areas for greater sensitivity when driving.

**COMPOSITION:** high grip silicone printed palms for perfect grip of the wheel and excellent breathing properties thanks to the smooth texture which does not allow worn fabric to accumulate. Pre-curved gloves with external stitching for a perfect fit. Breathable lining keeps the hands dry. Thumb and index finger with touch-screen areas for improved sensitivity and grip when adjusting carburetion and for using electronic devices. Direct printed backs and 3D rubber reinforcements. Pullers at wrists to facilitate dressing. Reinforcement at the carpal region to reduce impact damage during gear changes. Can be personalised from stock.



002552..AZ



002552..GF



002552..NR



002552..RS



# TRACK KG-3

Size: 7-13

Kid Size: 4-6

Track KG-3 kart gloves feature internal stitching and high grip silicon printed palms.

**COMPOSITION:** elasticised fabric with palms in combined material: synthetic suede with printed silicone for excellent scuff resistance. The printed areas were specifically designed to improve grip of the steering wheel. Pads between the fingers provide better breathing. Suede pullers to facilitate dressing. Elasticised wrists for a perfect fit. Can be personalised from stock.



002553..AZAF



002553..VF



002553..NR



002553..RS



## CRW

Size: S-XL
Kid Size: XXS-XS

Gloves in Neoprene with thermal welded seams and preformed high-grip ergonomic palm.  
**COMPOSITION:** 100% Neoprene with external fabric in 80% Nylon + 20% Spandex and 100% polyester lining.



00258NR..



sparco®





# KARTING HELMETS



## AIR KF-7W CARBON

### CARBON

SNELL K 2015



COL	SIZE	CODE	
CARBON	XS	53-54	0033540XS
	S	55-56	0033541S
	M	57-58	0033542M
	M+	59	0033543ML
	L	60	0033544L
	XL	61	0033545XL

The AIR KF-7W helmet has a carbon fibre shell reinforced with layers of carbon-Kevlar. The shell and EPS are manufactured in two sizes and has been designed to ensure excellent ventilation. The interior linings can be removed, washed and repositioned. The AIR KF-7W helmet can accommodate a drink system and the visor (FIA approved) can be constantly adjusted. Available in 6 sizes.



## SKY KF-5W KEVLAR/FIBERGLASS

### KEVLAR / FIBERGLASS

SNELL K 2015



COL	SIZE	CODE	
WHITE	XS	53-54	0033550XS
	S	55-56	0033551S
	M	57-58	0033552M
	M+	59	0033553ML
	L	60	0033554L
	XL	61	0033555XL
	XXL	62	0033556XXL
MATT BLACK	XS	53-54	0033550XSNR
	S	55-56	0033551SNR
	M	57-58	0033552MNR
	M+	59	0033553MLNR
	L	60	0033554LNR
	XL	61	0033555XLNR
	XXL	62	0033556XXLNR

The SKY KF-5W helmet has a carbon fibre shell reinforced with layers of carbon-Kevlar. The shell and EPS are manufactured in two sizes and has been designed to ensure excellent ventilation. The interior linings can be removed, washed and repositioned. The SKY KF-5W helmet can accommodate a drink system and the visor (FIA approved) can be constantly adjusted. Available in 7 sizes and in two colours.



# NEW GP KF-4W CMR

CARBON KEVLAR

SNELL CMR 2016



SIZE	CODE	
XS	54-55	0033580XS
S	56	0033581S
M	57-58	0033582M
L	59	0033583L

The new CMR helmet complies with new standard CMR2016, which is stricter than the preceding standard. The carbon Kevlar cap guarantees safety and lightness. The new CMR helmet is compatible with all Sparco accessories for full-face helmets.



CLUB X1

> PAGE 103



CLUB J-1

> PAGE 110



HELMET BAGS

> PAGE 114

HELMETS ACCESSORIES > PAGE 112



## NECK SUPPORT COLLARS

It features a special rear anatomic shape and variable density padding (more consistent in the helmet support area and softer under the chin and in the spoiler in order to reduce the weight of the helmet on the back).



COL	CODE	CODE (KID)
Blue	001602AZNR	001602AZNR-B
Red	001602RSNR	001602RSNR-B
Grey	001602GRNR	001602GRNR-B



## NEW KG 320

Diameter 320 mm. The steering wheels have anticorrosive aluminium hub and spoke, with TIG welding. Ergonomic grip, clad in real Alcantara® suede.

COL	CODE	
■	0158KG320NR	
Scamosciato - Suede - Ante		



## NEW KG 345

Diameter 345 mm. The steering wheels have anticorrosive aluminium hub and spoke, with TIG welding. Ergonomic grip, clad in real Alcantara® suede.

COL	CODE	
■	0158KG345NR	
Scamosciato - Suede - Ante		



Ø 100 mm

Scale 0 - 2,5 bar, aluminium handle, rubber cap, high-precision recording.

COL	CODE	
■	29424102C	

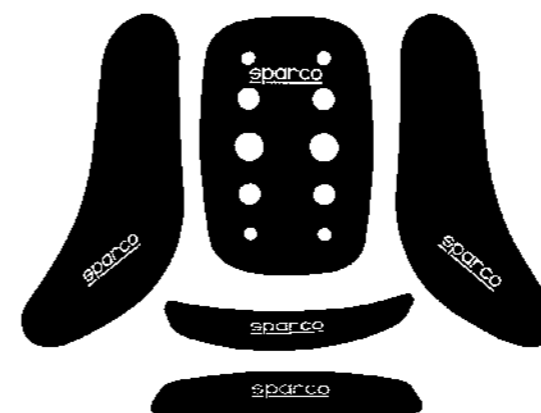

## ADHESIVE PROTECTION FOR SEATS

Adaptable to any type of seat. new density, softer. Color: black.

COL	CODE	
■	02798	



## TIRE BAG

Light and strong. Color: blue

COL	CODE	
■	02719AZ	



## KART COVER

Professional, very wide to suit any type of kart, with outline for the steering wheel, case included. Two colors, silver/blue and silver/red.

COL	CODE	
■	02712R	
■	02712A	

sparco®

OFFICIAL SUPPLIER OF YOUR PASSION

OFFICIAL SUPPLIER OF YOUR PASSION

OFFICIAL SUPPLIER OF YOUR PASSION







# TUNING SEATS

### THE ULTIMATE EVOLUTION OF THE SPORT SEATS

The SPX is handcrafted in Italy using the same technology and materials used for OEM super cars. In fact the SPX is the first Carbon Fiber reclining seat available to the public that meets the same specifications required by the OEM manufacturers. The SPX uses a combination of carbon fiber and advanced composites that give the driver both comfort and performance in a lightweight package. The SPX is covered in a combination of beautiful smooth Italian leather. The center of the SPX is covered in Alcantara® suede to allow you to gain absolute control of your vehicle and enhance your driving experience. To finish off the performance look, all hand stitching is done in tone-on-tone black with the Sparco logo embroidered in matching black. The backrest also features a micro adjustment knob that allows you to dial in the perfect driving position. The SPX is sold in driver and passenger versions (left and right).





	COL	CODE	
SPX	■	00974ZNRDX	
		00974ZNRSX	



## R600

Tubular steel frame. New micro seat back regulation, similar to top supercars. Ergonomic and comfortable padding. Covering: Jacquard. Quick tilting lever. Lower fixing 271x345. Compatible with 3 and 4 points safety harnesses.



	COL	CODE	
R600		00968NRRS	
		00968NRNR	



## EXPEDITION

SKY seat, specific for off road. High lateral support for back. Low lateral leg support, easy entry on high cars. 180° tilting.



	COL	CODE	
EXPEDITION		00969NRSKY	



# R333

Tubular frame. Double adjustment and reclining lever.  
Bot-tom fixing (271 x 345).  
Compatible with 3 or 4 fixing point harnesses



	COL	CODE
R333		00965NRGRS
		00965NRGR
		00965NR



# F200

Tubular steel frame chassis. Fixing points 271x345. Compati-  
ble with 3 and 4 points safety harnesses.  
3D fabric for improbe breathability



	COL	CODE
F200		00917RS
		00917AZ
		00917NR



# R100

## R100 SKY

THIS SEAT IT'S COMPLIES  
WITH REGULATION:  
E/ECE/324/REV.1/ADD.16/REV.5  
E/ECE/TRANS/505/REV.1/ADD.16/REV.5

Tubular steel frame chassis. Fixing points 271x345. Compatible with 3 and 4 points safety harnesses.  
3D fabric for improve breathability



	COL	CODE
R100 TESSUTO FABRIC-TELA		00961NRRS
		00961NRGR
		00961NRAZ
		00961NRRR
R100 SKY		00961NRSKY



R100 SKY

### SEATS DIMENSIONS

Mod.	SPX	R600	R333	EXPED.	F200	R100
A	-	300	280	300	345	300
B	482	530	500	500	450	500
C	362	280	360	370	330	350
D	481	540	530	500	490	500
E	542	570	520	460	520	500
F	480	440	490	440	410	440
G	615	640	590	560	520	540
H	-	-	-	-	290	-
I	145	-	-	-	110	-
L	622	580	620	700	550	700
M	940	910	920	-	860	930
Kg	18	19,80	15,50	14,00	8,80	13,30

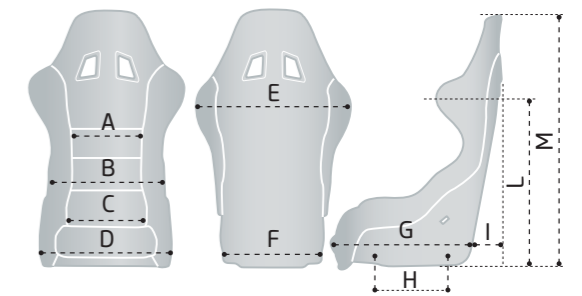



## SEAT SLIDES, SUBFRAMES FOR BOTTOM MOUNTING

ADAPTOR for racing seats on seat rails

CODE	00497RACE	
------	-----------	--

Example of specific frame. For the complete application list see the price list.



UNIVERSAL FITTING KIT - with 4 brackets with height adjustment, 2 reinforced aluminium corner pieces and the necessary screws and nuts.

CODE	00495	
------	-------	--



UNIVERSAL SUBFRAME - with mechanism to adjust the height of the seat, for cars with removable slides from the original seat with distance between slides up to 430 mm.

CODE	00491	
------	-------	--



TILT FORWARD BRACKET - to be fitted between slides and subframes to allow easy access to the rear seats also on cars with front seats with fixed backrest.

CODE	00494	
------	-------	--



SET OF SLIDE RUNNERS - Longitudinal distance 271 mm

CODE	0049302	(Economical - Economical- Baratas)	
CODE	00493	(Top quality - Top de qualidade)	

# sparco®





# SPORT HARNESSES



## 04604 BM

ECE

4 fixing points, snap on,  
lap reinforcement.

COL	CODE
<span style="color: red;">■</span>	04604BMRS
<span style="color: blue;">■</span>	04604BMAZ
<span style="color: black;">■</span>	04604BMNR
<span style="color: gray;">■</span>	04604BMSGR

## 04608 DF

ECE

3 fixing points, double buckle, snap on and lap  
reinforcement.

COL	CODE
<span style="color: red;">■</span>	04608DFRS
<span style="color: blue;">■</span>	04608DFAZ
<span style="color: black;">■</span>	04608DFNR
<span style="color: gray;">■</span>	04608DFSGR

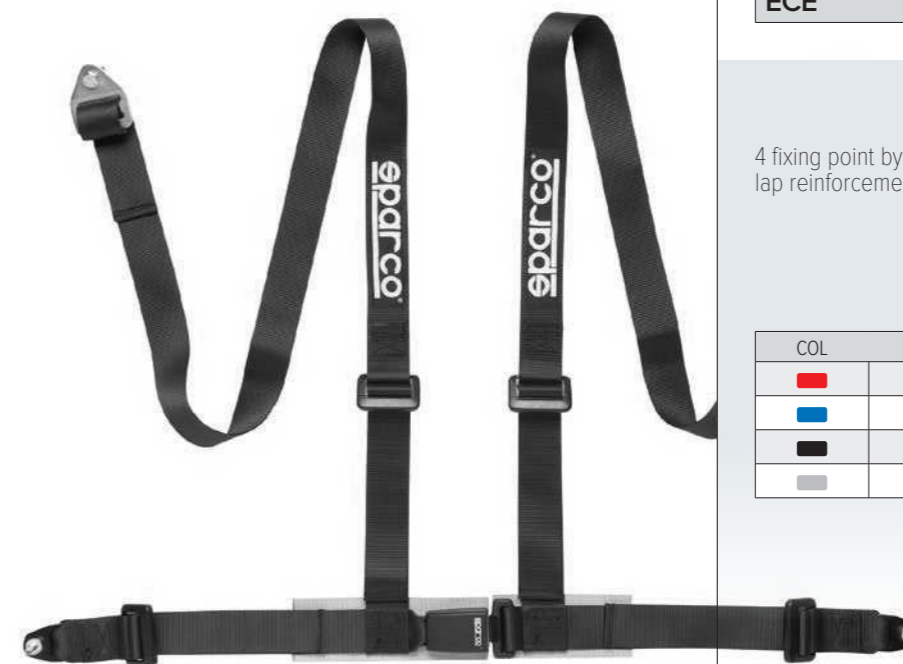

## 04604 BV

ECE

4 fixing point by bolt with  
lap reinforcement.

COL	CODE
<span style="color: red;">■</span>	04604BVRS
<span style="color: blue;">■</span>	04604BVAZ
<span style="color: black;">■</span>	04604BVNR
<span style="color: gray;">■</span>	04604BVSGR

## 04608 BV

ECE

Cintura a 3 punti, fissaggio a vite.

3 bolted fixing points.

3 puntos de fijación a tornillo.

COL	CODE
<span style="color: red;">■</span>	04608BVRS
<span style="color: blue;">■</span>	04608BVAZ
<span style="color: black;">■</span>	04608BVNR
<span style="color: gray;">■</span>	04608BVSGR

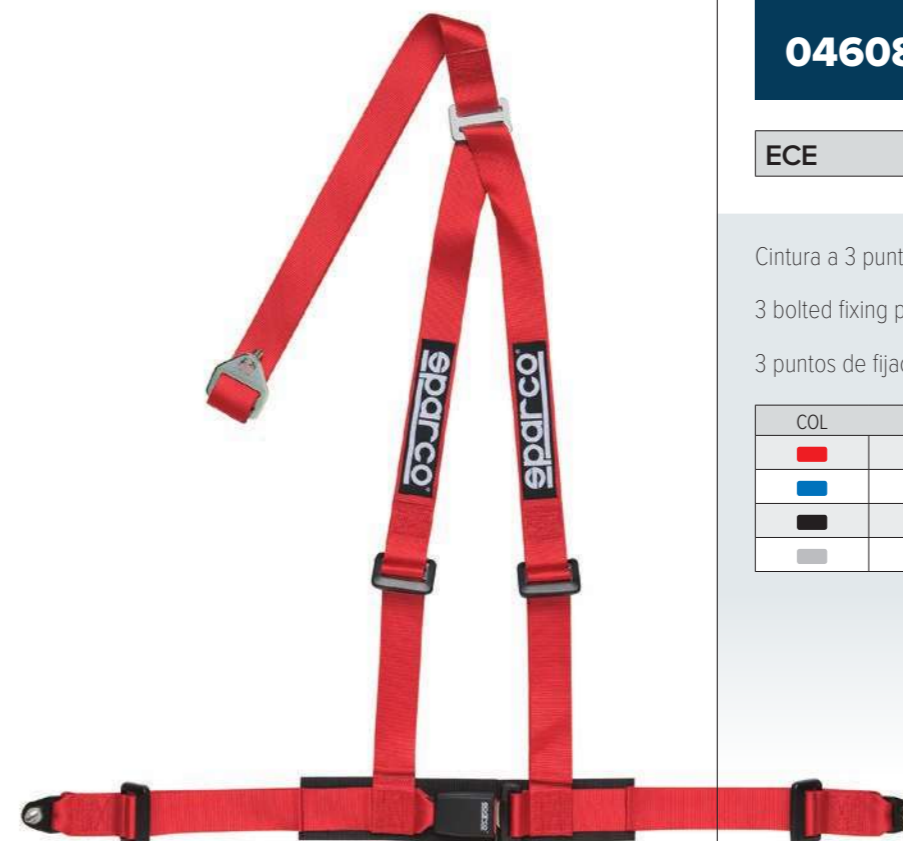





## SPORT

Sottile. Thin. Delgado.

COL	CODE
	01090S4AZ
	01090S4RS
	01090S4NR



## GT

Sottile. Thin. Delgado.

COL	CODE
	01090R3AZ
	01090R3RS
	01090R3NR



## 77

Sottile. Thin. Delgado.

COL	CODE
	0109077BIAZ
	0109077AZ
	0109077RS
	0109077NR



## MINI

Pair of pads in Alcantara® with high grip neoprene inner layer. Useful to improve comfort of driving when fitted on steering wheels or handbrake handle.

COL	CODE
	01099NR
	01099RS
	01099AZ

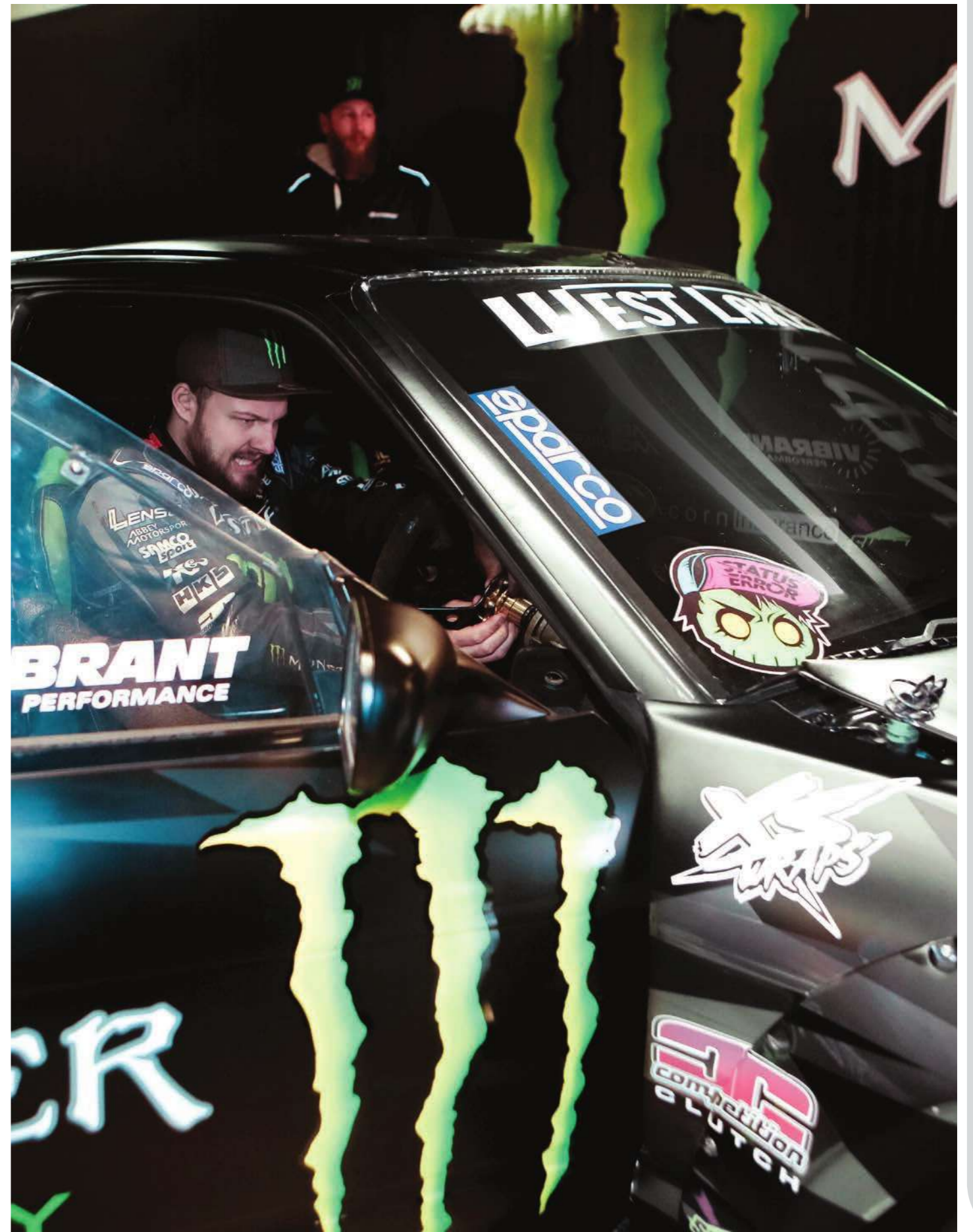



**SAFETY & COMFORT FROM MOTORSPORT**

# SEATS FOR SPORTS

## STADIUM & OFFICE SEATS

Sparco sport seats stem from the experience of over 30 years on tracks around the world in the racing field. Sparco, through its R&D experience, has created a comfortable and anatomic seat for all needs and for all athletes, whether professional or amateur, starting from the racing seats used in the World Rally Championship (WRC) to achieve a seat characterized by high performance with excellent rigidity/weight ratio. Fundamental features are the padding and high density memory foams, designed to improve the posture of the athlete while resting.

A world of possibilities for you:

The benches can be customised with logos and with many the colours available: all you have to do is send the high definition company logo to Sparco and everything else will be taken care of by the Sparco graphics department to implement the perfect seating for your needs. You can include the name and surname of your affiliate, your chairman or anyone who wants their own unique seat: that's why the seats are not just for sports benches, but can become comfortable chairs for the office, meeting rooms or press conferences

A world of colours and possibilities await you, and if everything that Sparco provides on paper does not satisfy you, try the new Sparco online configurator, the customization possibilities are infinite



OFFICIAL  
SUPPLIER:



PALLAVOLO  
**PADOVA**

trentino volley



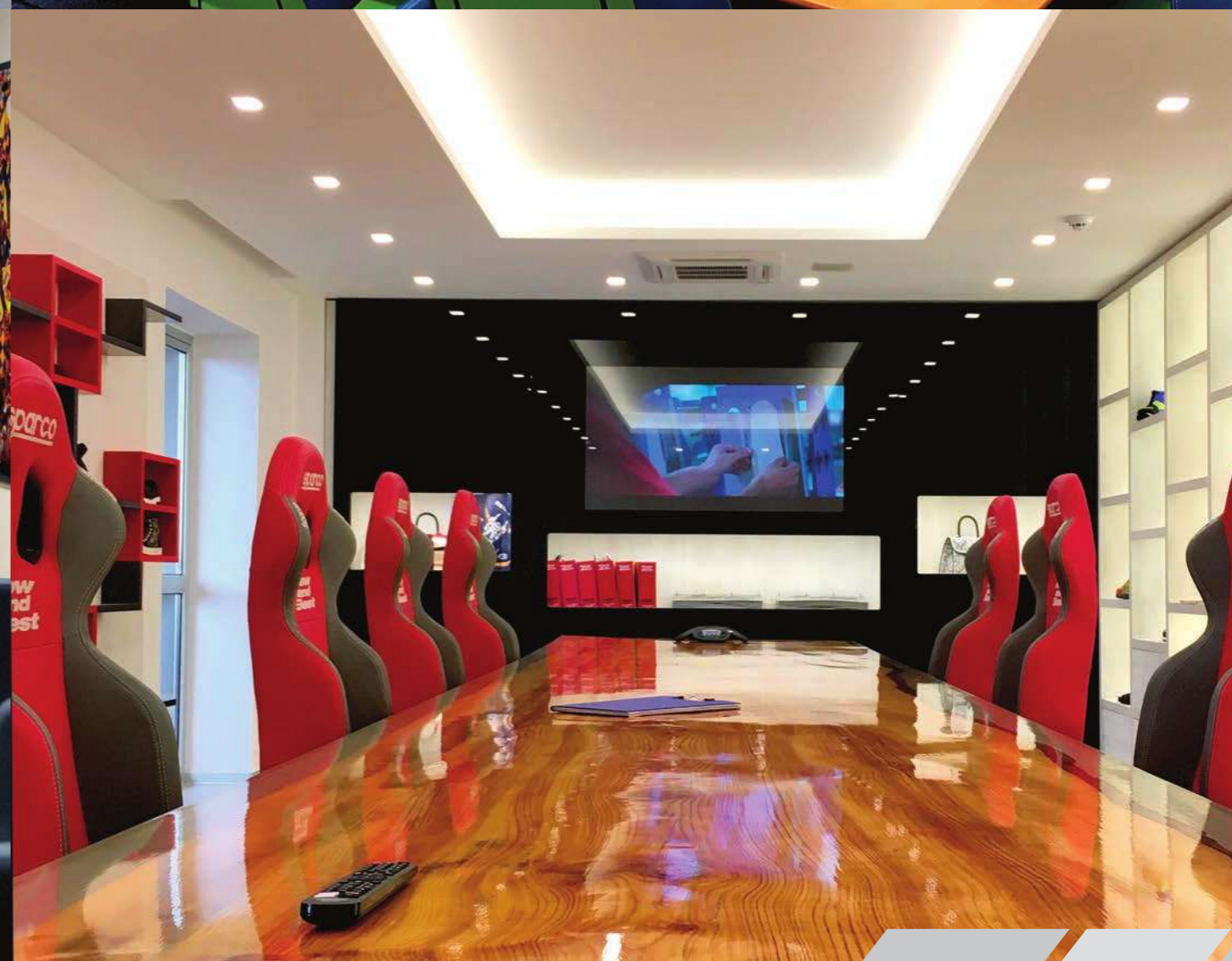





# SPORT STEERING WHEELS

# L 777

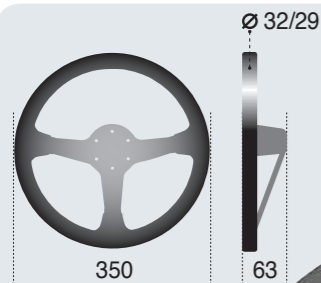

COL	CODE
■	015L800PL
Pelle - Leather - Piel	



COL	CODE
■	015L800SC
Scamosciato - Suede - Ante	



COL	CODE
■	015L800PLAR
Pelle - Leather - Piel	



COL	CODE
■	015L800SCAR
Scamosciato - Suede - Ante	

# L 550

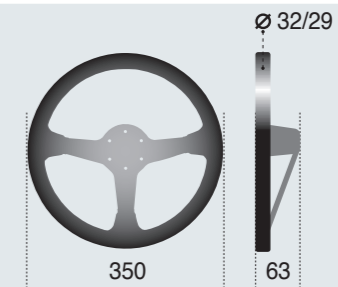

COL	CODE
■	015TMZL9
Pelle - Leather - Piel	



COL	CODE
■	015TMZS1
Scamosciato - Suede - Ante	

# L 575

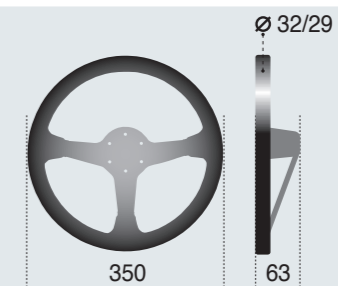

COL	CODE
■	015L750PL
Pelle - Leather - Piel	



COL	CODE
■	015L750SC
Scamosciato - Suede - Ante	



COL	CODE	
■	015TSFL9	
Pelle - Leather - Piel		

## L 555

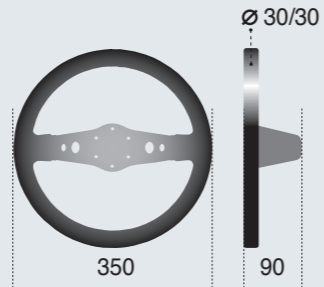

COL	CODE	
■	015TSFS1	
Scamosciato - Suede - Ante		

## L 505



COL	CODE	
■	015TL522TUV	
Pelle/Scamosciato - Leather/Suede - Piel/Ante		

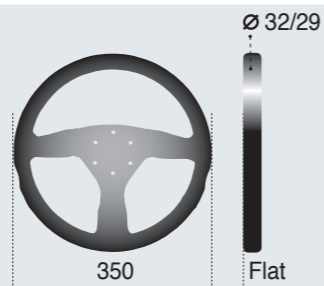

COL	CODE	
■	015TRGL1TUV	
Pelle - Leather - Piel		

## L 360

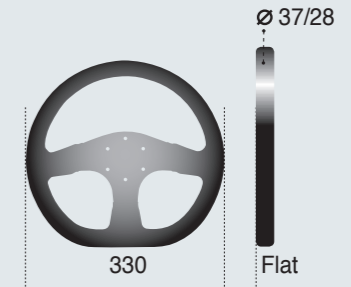

COL	CODE	
■	015TRGS1TUV	
Scamosciato - Suede - Ante		

## L 999



COL	CODE	
■	015TMG522TUV	
Pelle/Alcantara®-Leather/Alcantara®-Piel/Alcantara®		

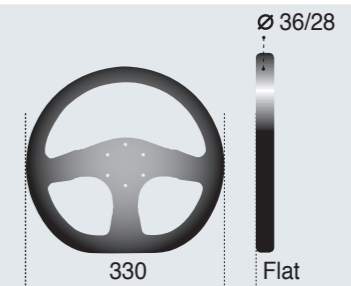



P 222

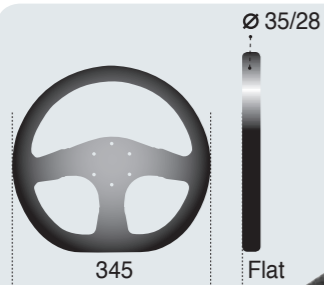

COL	CODE	
■	015THPUGR345	
Poliuretano - Polyurethane - Black/Silver		



COL	CODE	
■	015THPUNR345	
Poliuretano - Polyurethane - Black/Black		

P 104 SPORT

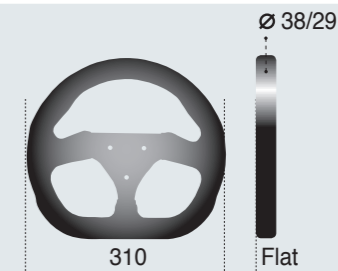

COL	CODE	
■	015THIP311	
Poliuretano - Polyurethane		



## HUB

FOR THE COMPLETE APPLICATION LIST  
SEE THE PRICE LIST



Sparco collapsible hubs are cast iron made with a steel frame that collapse during impacts. This item absorbs kinetics energy avoiding transfer to the driver.

The Sparco steering wheels are TÜV approved only if coupled with the Sparco hubs.

## QUICK RELEASE STEERING



CNC machined with steel spline. Black anodized and orange. Uni-versal fixing system for 3 or 6 fixing point, steering hub, steering column.

CODE	015R98TU	

## RACING PUSH BUTTONS KIT



Supporti anodizzati nero con pulsanti  
Black anodized supports with push buttons  
Soporte negro anodizado con botones de pulsación

CODE	015NE981	(1 push button)	
CODE	015NE982	(2 push buttons)	



## ANODIZED STEERING WHEEL SPACERS



COL	CODE	
■	01595ANR	
■	01595ANT	

## GHIERE • RING • ARO



Anodized aluminium

CODE	01599NR	

## CENTER CAPS FOR HORN BUTTON

Set of 10 center caps for Sparco horn buttons



01597GZ

01597GN

01597GG

01597GR

## ECCENTRING RING



Adapter for small diameter steering wheels to obtain a proper dashboard visualization.

CODE	01592N	



Painted aluminium

COL	CODE	
■	01598RS	
■	01598NR	



# SPORT GEAR KNOB PEDAL SETS



### PIUMA

Lightened grey/black gear knob.



COL	CODE
■	03741BN01
■	03741BT01



### TRALICCIO

Pomello forato con impugnatura a sfera.  
Drilled gear knob with sphere handgrip.  
Pomo perforado con empuñadura esférica.

COL	CODE
■	03740TR



### SETTANTA

Titan/black two colour gear knob.



COL	CODE
■	03736AT
■	03736AO



### SETTANTA R

Titan/black two colour gear knob for reverse gear.



COL	CODE
■	03737TS
■	03737NS



### RACING

Spherical gear knob. Universal mounting on all gear stick with a max diameter 15 mm. Not suitable for gearbox with syringe safety stop. Made by aluminium. External diameter 48 mm.



COL	CODE
■	037401CL (carbon look)
■	037401AN (anodised)
■	037401CR (chromed)



### GLOBE

Chromed gear knob with leather insert for reverse gear.

COL	CODE
■	03745PTN



### TECNO

Chromed or wrapped in perforated leather gear knob.



COL	CODE
■	03747PTN
■	03747CR



### SPEED

Chromed gear knob with leather insert.

COL	CODE
■	03744PTN

ECE

Reflex kit universal pedals, ECE.

COL	CODE
■	0378713
●●	03787K13 (Rubber kit)



## REFLEX



Set of universal pedals.

COL	CODE
■	0378703 (NO ECE)
●●	03787K03



Set of pedals, long accelerator pedal.

COL	CODE
■	0378723
●●	03787K3



Automatic gear, long accelerator pedal.

COL	CODE
■	0378724
●●	03787K4



Pedals set, automatic gear.

COL	CODE
■	0378704 (NO ECE)
●●	03787K04

ECE

Lightened universal black or silver pedal, ECE



## PIUMA



Set of universal pedals.

COL	CODE
■	037879BC01
■	037879BT01

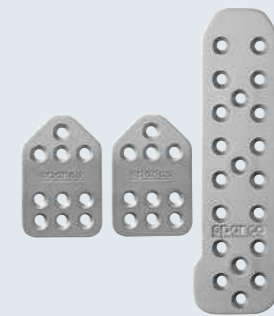

Set of pedals, long accelerator pedal.

COL	CODE
■	037879BAFN
■	037879BAFT

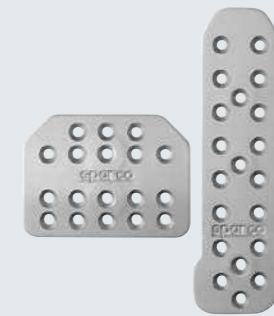

Automatic gear, long accelerator pedal.

COL	CODE
■	037879BAAN
■	037879BAAT



Pedals set, automatic gear.

COL	CODE
■	037879BATN
■	037879BATT

ECE

Lightened universal black or silver pedal.



## SETTANTA



Set of universal pedals.

COL	CODE
	037879OP01
	037879IT01



Set of pedals, long accelerator pedal.

COL	CODE
	037879OP04



Automatic gear, long accelerator pedal.

COL	CODE
	037879IT02 (until stock last)



Driver footrest in aluminum

COL	CODE
	03788NR (until stock last)
	03788TI (until stock last)



Universal handbrake

COL	CODE
	03753NR
	03753TI



Driver footrest in shiny aluminium

COL	CODE
	03788BRI

## SETTANTA

## REFLEX

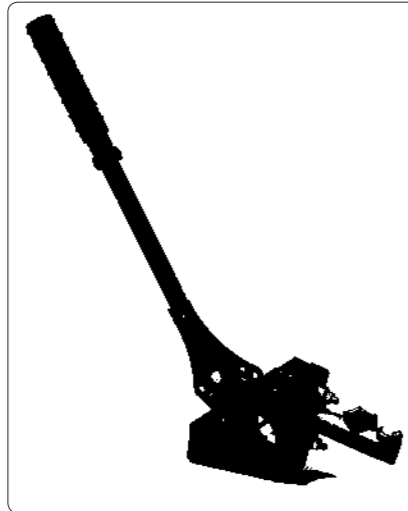
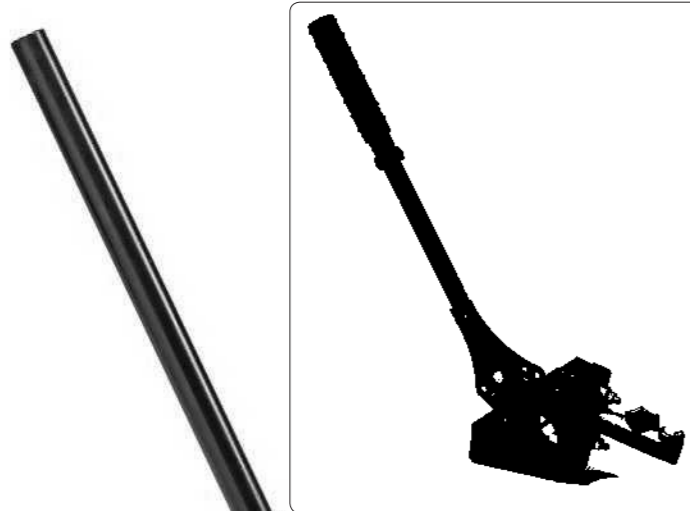

## DRIFTING

### HYDRAULIC BRAKE LEVER

Hydraulic brake lever, Girling compatible. Horizontal or vertical fitting (uniball adjusting). 20 mm tube. Black. Sold individually. **Lever cap, uniball and Gir-ling system not included.**

COL	CODE	
■	037521FPLNR	

### HAND BRAKE LEVER

Aluminum hand brake lever. Black aluminum tube, with anti-slip o-ring. Height adjusting up to +15 cm with additional part. Complete with screws and instructions. Fitting diameter: 20 mm.

COL	CODE	
■	03735NR	

### GEAR KNOB

Aluminum gear knob standard (not suitable for syringe engagement). Black or anodized aluminum tube, with anti-slip o-ring. Height adjusting (more than 10 cm) with additional part. Complete with screws and instructions. Fitting diameter: 15 mm.

COL	CODE	
■	03734NR	



### NAVIGA

5 mm anodized aluminium sheet, laser cutted. Pre drilled for easy fitting on the floor, or on the MAT floor, adjustable angle; dimensions about cm 36 x 28. High quality materials.

COL	CODE	
■	03789TAN	

### MATT

5 mm anodized aluminium sheet, laser cutted. Pre drilled for easy fitting dimensions about cm 50 x 38. High quality materials.

COL	CODE	
■	03789RAN	

### CARBON

3-piece set in pre-bent and shaped mixed carbon. Brake and clutch with non-slip inserts

COL	CODE	
■	03783L (NO ECE)	

## SPACERS

FOR THE COMPLETE APPLICATION LIST PLEASE CHECK PRICE LIST.



Developed in a special aluminium alloy through an innovative forging technology, afterwards they are wrought with CNC machine (computer numerical control) to obtain the perfect coplanar surface. They are heat treated to increase the mechanical resistance and next they are anodized to guarantee the oxidation protection. The application table includes the most popular application available in the market, bolts and studs included. The wheel spacers increased the track improving the driving precision.

**Important:** the use of wheel spacers modify the suspension geometry, that needs to be revised afterwards.

## AERO FUEL CAPS



CODE	
27004CR	
Cromato. Chromed. Cromado	



CODE	
27004OA	
Oss. Argento. Silver-Oss. Plata	



CODE	
27009G	

## UNIVERSAL AIR BOX



CODE	
030HP002	
Filtro HP300 - HP300 Filter - Filtro de aire HP300	



CODE	
030HP003	
Filtro HP160 - HP160 Filter - Filtro de aire HP160	



Connection tube for HP300 and HP160.

CODE	
030HP001	

## HP 300

• Universal air filter. Intended for cars which develop up to 300 bhp. Includes universal assembly kit. Requires some modification of the air intake assembly.

CODE	
030HP300	

## HP 160

• Filtro aria universale. Sviluppato per vetture fino a 160 hp di potenza. Kit di montaggio universale incluso. Necessita la modifica all'impianto di aspirazione.

• Universal air filter. Intended for cars which develop up to 160 bhp. Includes universal assembly kit. Requires some modification of the air intake assembly.

• Filtro de aire universal. Desarrollado para automóviles de hasta 160 hp de potencia. Juego de montaje universal incluido. Precisa una modificación de equipo de aspiración.

CODE	
030HP160	



CODE	
030AC005	
Detergente - Cleaner - Detergente	

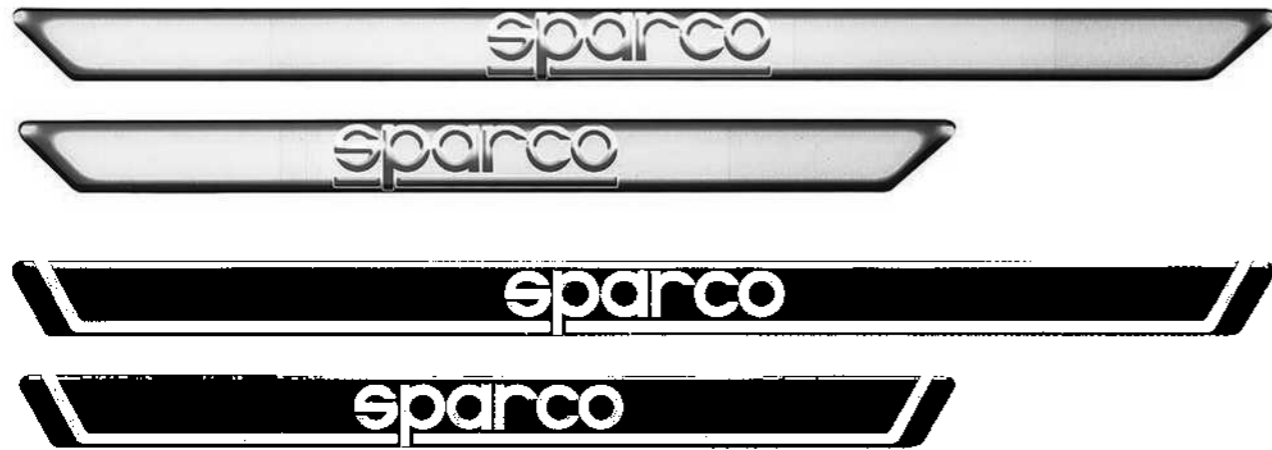

**SILL GUARD**

Set of 2 sill guard 3D flexible adhesive

	CODE	
605 x 35 mm	03769A	
450 x 35 mm	03769B	

Carbon sill guard 3D flexible adhesive

	CODE	
605 x 35 mm	03770CAR...	
450 x 35 mm	03769CAR...	

**BASIC**

Gear knob gaiter in ecological leather with Sparco embroidered logo.

COL	CODE	
	037541NRRS	
	037541NRAZ	
	037541NRAR	

**NEW STRADA**

Set of 4 carpet in 2 sizes (A and B) with vinyl insert.

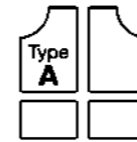

Suitable for all cars with conventional accelerator.

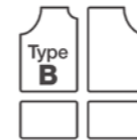

Suitable for all cars with floor accelerator.



FOR THE COMPLETE APPLICATION LIST PLEASE CHECK PRICE LIST

**TYPE A**

COL	CODE	
	03763ARS	
	03763ABS	
	03763AAR	
	03763ANR	

**TYPE B**

COL	CODE	
	03763BRS	
	03763BBS	
	03763BAR	
	03763BNR	

**DON'T FORGET TO USE IT**

OPTIONAL

Fixing universal kit for carpet (10 pcs per box)

PCS	CODE	
10	03768PU	

## BONNET PINS



01606S	01606AA	01606AR	01608
--------	---------	---------	-------

**01606S** - Pair of stainless steel bonnet pins with captive slide pin.

**01606A** - Pair of aluminium bonnet pins, anodised blue or red with captive slide pin.

**01608** - Pair of stainless steel spring hooks.

## MUD FLAPS



Curved polyethylene mud guards kit thickness 1,5 mm not FIA compliant.

COL	CODE
□	03791
■	03791RS
■	03791AZ
■	03791NR

**sparco**<sup>®</sup>



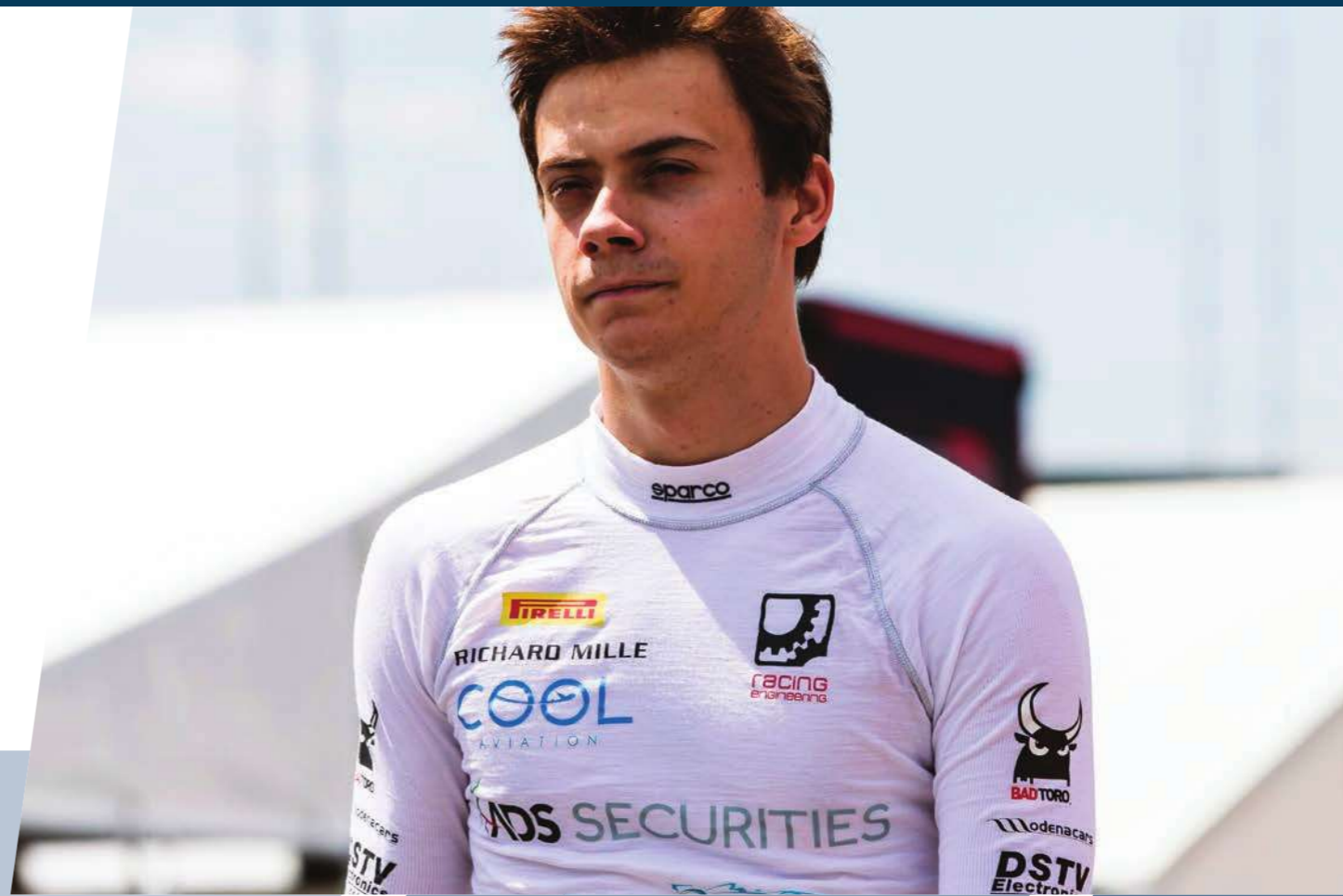

OFFICIAL SUPPLIER OF YOUR PASSION



sparco®

OFFICIAL SUPPLIER OF YOUR PASSION



OFFICIAL SUPPLIER OF YOUR PASSION



# TEAMWEAR



## SOFT SHELL

Size: XS-XXL



011764NR..

011764BM....

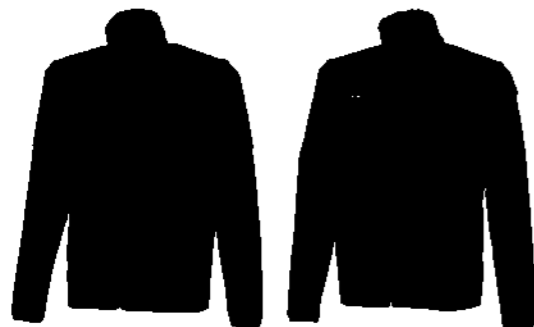

Soft shell DROP TEX with inside napping.

**COMPOSITION:** 47% polyamide 41% polyester 12% elastane (polyurethane) 350 g/m<sup>2</sup>.

**FEATURES:** Drop repellent and wind stopper fabric, 3 external pockets and elastic cuffs. It is possible to personalize this item with colours, printings and embroideries (Sparco guideline).



## SWEATSHIRT

Size: XS-XXL



011756NR..

011756BM..



Full zip cotton sweatshirt with lateral pockets.

**COMPOSITION:** 100% polished cotton (internal brushed) 310 g/m<sup>2</sup>.

**CHARACTERISTICS:** Sweatshirt in soft polished cotton with cuffs and bottom ribs. It is possible to personalize this item with colours, printings and embroideries (Sparco guideline).



# POLO

Size: XS-XXL



011886NR..

011886BM..

011886BI..



**COMPOSITION:** 100% cotton 190 g/m<sup>2</sup>

**FEATURES:** Breathable cotton fabric. It is possible to personalize this item with colours, printings and embroideries (Sparco guideline).



# SHIRT

Size: XS-XXL



**COMPOSITION:** 100% cotton 130 g/m<sup>2</sup>

**FEATURES:** Lightweight and breathable cotton fabric. Pocket with pen holder. It is possible to personalize this item with colours, printings and embroideries (Sparco guideline).

011774BI..



# CARGO

Size: XS-XXL



**COMPOSITION:** 35% Cotton 65% polyester 210 g/m<sup>2</sup>

**FEATURES:** Wear resistant fabric, lightweight and breathable. Lateral and back pockets with velcro closure. Tools hooks on the front and on the back. Elastic on waist. It is possible to personalize this items with colours, printings and embroideries (Sparco guideline).

011496NR..



# NEW SH-17

Size: 36-46



**CHARACTERISTICS:** Fashionable low shoe made of light leather and breathable fabric with two-tone recyclable 100% TPR sole. A leisure shoe designed with Sparco's typical features: curves like those on the SPX seatbelt slider on the heel, the curves of the Sparco racing suits on the shoulder parts on the sides and the detail of the R100S seatbelt fastener as the lace holes.



001262..SIAZ



001262..BM



001262..NRRS



001262..NR



## TIME 77

Size: 36-46

until stock last

Interamente in pelle. Completely in leather. Toda de piel.



001205..NRVD



001205..BI



001205..NR

## ESSE

Size: 36-46

until stock last

Interamente in pelle. Completely in leather. Toda de piel.



001201..BI

## ESSE

Size: 36-46

until stock last

Made of fabric, leather and suede.



001202..BI

## MX RACE > PAGE 245





# UNIVERSE

016429NR



H 40 x L 81 x P 35 · 110 Lt

Large size trolley. 600 polyester fabric with synthetic leather inserts. Reinforced base. Adjustable shoulder strap. Retractable trolley handle. Padded carry handles with Velcro closure. Name holder. Large main compartment with double internal zip pocket. Double-bottomed with zip and removable lateral reinforcements. Padded helmet compartment. Shoes compartment. External lateral document holder with zip. Customizable.



# PLANET

Wheeled bag. 600 polyester fabric with synthetic leather inserts. Reinforced base. Adjustable shoulder strap. Carry handles in fabric with Velcro padded closure. Name holder. Large main compartment with double internal zipped pocket. Internal pocket. Shoes compartment. Customizable.



zapatos. Se puede personalizar.

CODE

016430NR



H 35 x L 65 x P 30 · 68 Lt

# SATELLITE

Cabin trolley. 600 polyester fabric and synthetic leather. Exterior removable front pocket zip usable as a backpack, with shoulder straps and single handle pull-out. Exterior rear pocket and name holder. Extendable handle. Customizable.



CODE

016431NR



H 50 x L 35 x P 20 · 35 Lt



## GALAXY

Flap-over laptop. 100% PVC fabric. Double buckle closure. Velcro closure front pocket and zipped rear pocket. Wide storage compartment with zipped pocket, mobile and pen holder. Lateral exterior mobile pocket. Adjustable shoulder strap. Water resistant material.

CODE		
016434NRBI		
H 28 x L40 x P 8 · 9 Lt		

## STARS



Backpack. 600 polyester fabric with synthetic leather inserts. Ergonomic and breathable backrest. Padded shoulder straps. Lateral and front storage pockets. Large front pocket with synthetic leather finishes, document and pen holder compartment with zipped pocket  
Laptop padded rear pocket with secure lock, storage compartment and zipped pocket. Customizable

CODE		
016432NRBI		
H 40 x L34 x P 20 · 27 Lt		



CODE		
016432NR		
Untill stock last		

## NEW TRIP 3



Trip3 Bag in polyester fabric with rubber edging and reinforcements on the sides. Rubber rest feet. Internal pocket with zip fastener. Very capacious, well-organised, with three different compartments and zips. Adjustable shoulder strap. Fabric handles with padded Velcro closure

CODE		
016522NRGR		



## CODRIVER

Multipockets co-driver bag. 100% Polyester. Frontal removable space.

CODE		
016428NR		
H 37 x L30 x P 14/20 · 22 Lt		



## COSMOS

Helmet and HANS bag.

CODE		
016433NR		
H 35 x L35 x P 40 · 50 Lt		

> PAGE 114

sparco®

OFFICIAL SUPPLIER OF YOUR PASSION

OFFICIAL SUPPLIER OF YOUR PASSION

OFFICIAL SUPPLIER OF YOUR PASSION



OFFICIAL SUPPLIER OF YOUR PASSION



sparco®

OFFICIAL SUPPLIER OF YOUR PASSION



OFFICIAL SUPPLIER OF YOUR PASSION

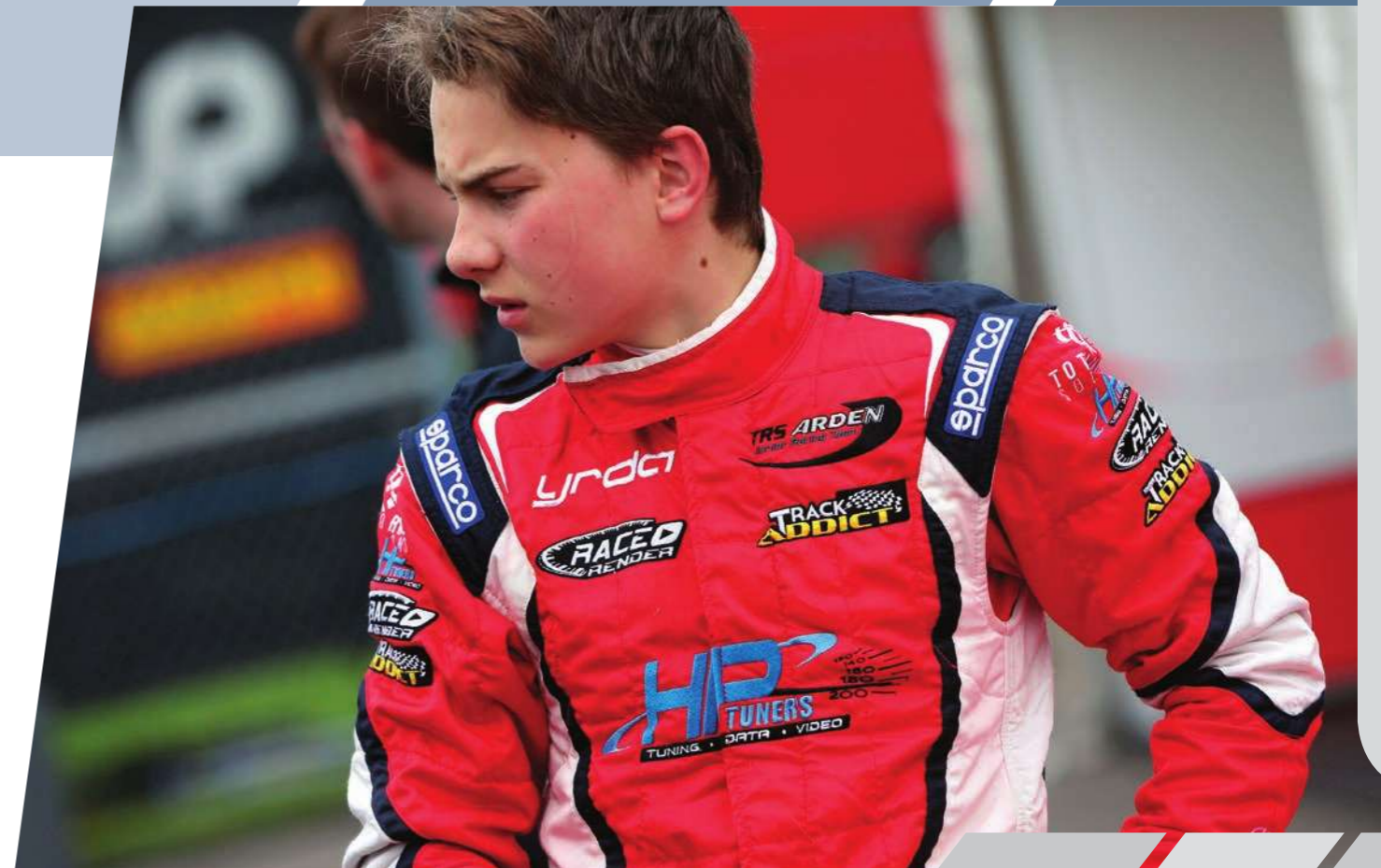



# MERCHANDISING



### HOODIE 1977

SIZE	CODE	
S - XXL	01226BI...	

COMPOSITION: 80 % cotton - 20% polyester - brushed 280 g/m<sup>2</sup>. CHARACTERISTICS: Sweatshirt with lined hood, drawstring and practical pouch pocket. Shoulders and underarms with flat stitching. Flock print.



### HOODIE PERFORMANCE

SIZE	CODE	
S - XXL	01227BM...	



### FULL ZIP 40TH

SIZE	CODE	
S - XXL	01228NR...	

COMPOSITION: 80 % brushed cotton - 20% polyester - brushed - 280 g/m<sup>2</sup>. CHARACTERISTICS: inner zip, high ribbed neck. Side pockets with reinforced stitching. Embroidery, patches and prints.

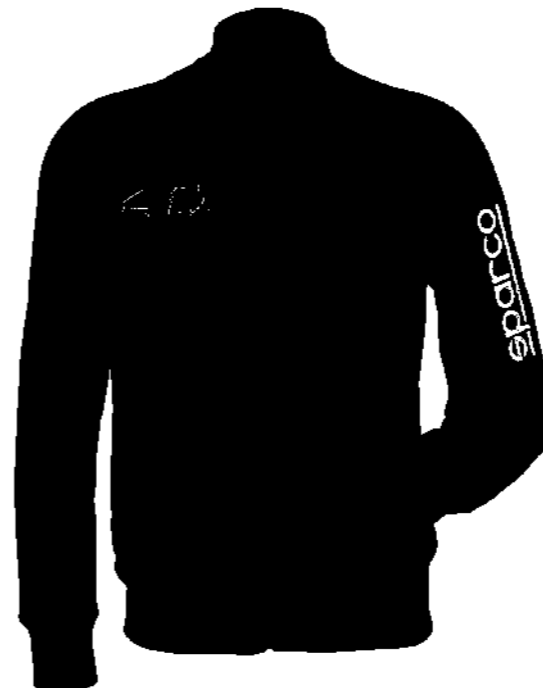

SIZE	CODE	
S - XXL	01228BM...	

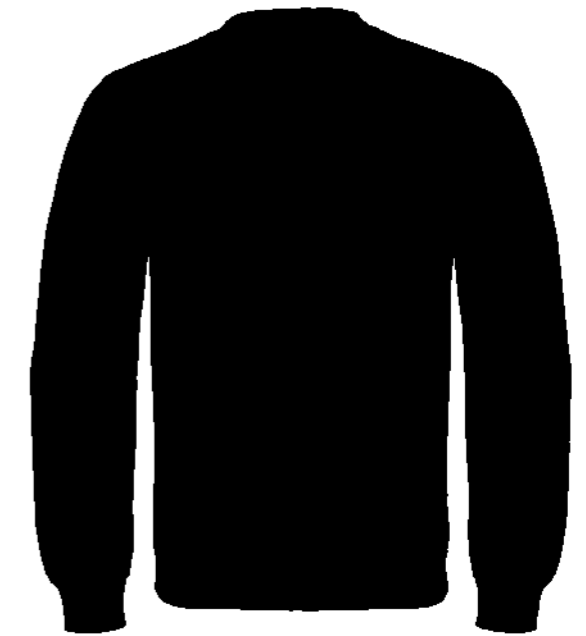

### 1977

SIZE	CODE	
S - XXL	01225NR...	

COMPOSITION: 80 % cotton - 20% polyester - brushed - 280 g/m<sup>2</sup>. CHARACTERISTICS: Soft modern crew neck sweatshirt with ribbed neck, wrists and hems in Lycra. Flock print.

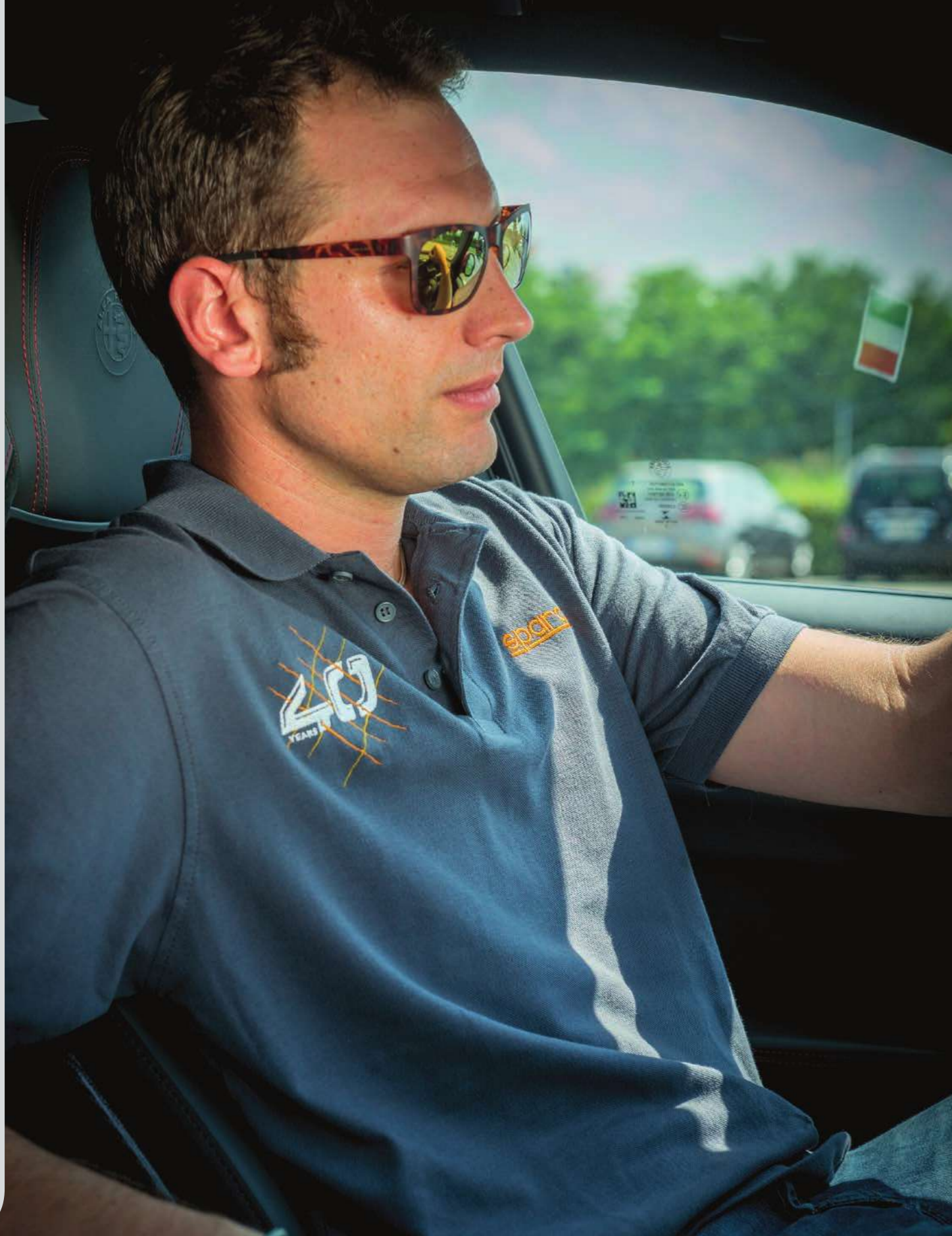

## POLO

## 40TH



SIZE	CODE	
S - XXL	01224BM...	

## SKID



SIZE	CODE	
S - XXL	01223NR...	

COMPOSITION: 100 % COTTON PIQUE - 180 g/m<sup>2</sup>.  
 CHARACTERISTICS: polo in cotton pique with flat ribbed neck, graphics with embroidery, patches and prints.

## 40TH



SIZE	CODE	
S - XXL	01224GR.....	

## PERFORMANCE



SIZE	CODE	
S - XXL	01222BI...	

## T-SHIRTS

COMPOSITION: 100% COTTON - 160 g/m<sup>2</sup>. CHARACTERISTICS: T-shirt in soft, breathable fabric. Ribbed cotton collar and inner tape at shoulders. Graphics in soft digital print.

SIZE	CODE	
S - XXL	01219NR...	



TRON

SIZE	CODE	
S - XXL	01216NR...	



40TH

SIZE	CODE	
S - XXL	01221AZ...	



GO!

SIZE	CODE	
S - XXL	01217BI...	



1977

SIZE	CODE	
S - XXL	01220AZ...	

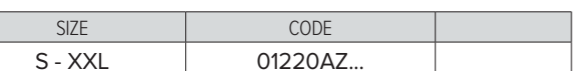

SIZE	CODE	
S - XXL	01217BI...	



1977

SIZE	CODE	
S - XXL	01215BM...	



TRACK

SIZE	CODE	
S - XXL	01217BM...	



1977

SIZE	CODE	
S - XXL	01218BI...	



DRIVER



TRACK



40TH

SIZE	CODE	
S - XXL	01215BI...	

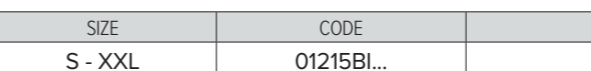

SIZE	CODE	
S - XXL	01216BI...	



40TH



**REBEL**

SIZE	CODE	
Single Size	01229NR	

COMPOSITION: 100% acrylic fabric with pvc adjustable strap.  
 CHARACTERISTICS: Original cap with flat peak and embroidered 3D graphics at front. Sparco 1977 sticker on peak.

**1977**

SIZE	CODE	
Single Size	01230NR	

COMPOSITION: 100% acrylic fabric - polyester mesh - with pvc adjustable strap. CHARACTERISTICS: Flat peak cap with embroi-dered graphics and 3D Sparco logo. Sparco 1977 sticker on peak.

**40TH**

SIZE	CODE	
Single Size	01231BM	

COMPOSITION: 97% cotton - 3% elasticised spandex.  
 CHARACTERISTICS: Innovative design in flexfit style with embroi-ery, prints and 3D Sparco logos. Sparco Performance sticker on peak.

**WINDY**

SIZE	CODE	
Single Size	01232BMAZ	

COMPOSITION: 100% acrylic fabric. CHARACTERISTICS: Soft winter hat with two-colour pom-pom and ribbed turn up with embroi-dered fabric Sparco logo. Original Sparco label sown on back.

**PADDOCK CHAIR**

The comfortable Sparco paddock Chair has an aluminium frame and is finished in coloured Oxford 600D fabric. The soft arms are padded for maximum comfort at all times. Easy to transport thanks to its folding mechanism.

CODE	0990058	

**POUF**

Soft pouf diameter 40 cm, height 40 cm, with printed S logo in the upper surface.

CODE	0750006B	





Case and buckle: stainless steel 316L. Case diameter: 47 mm. Swiss made eta 2824/2 automatic and anti-magnetic incabloc movement. Black pvd rotating bezel. Screw-down crown. Date display. Water resistant 50 atm with automatic helium valve. White super-luminova dial and hands. Mineral glass. Screw back case.

CODE	099035NR
------	----------



099013NR	099014BM	099014RS
(MAN)		



099042GI	099042VE	099042AZ
----------	----------	----------



**NEW ANNIVERSARY**

CODE	099057
------	--------



099016VI	099017NR
(WOMAN)	



099043RS	099043VE
----------	----------



Polyester automatic umbrella. Ø 127 cm

CODE	099007
------	--------



099047	Glove
099049	Suit



Set of 10 badge

099BADGE
----------



KIT OF 16 STICKERS

Punched sticker rally paper

ASPA001
---------

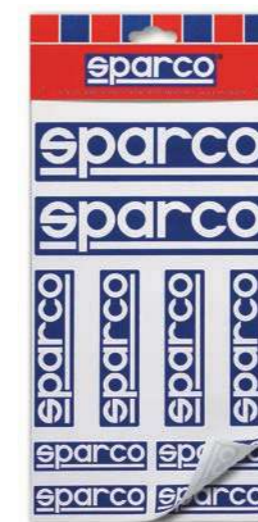

KIT OF 20 STICKERS

4 pcs 15 cm +  
8 pcs 10 cm +  
8 pcs 7.2 cm

09001
-------



SPARKY

099051
--------

## R100 S



00975NRAZ

00975NRVD

00975NRNR



010801

010702

Spare parts kit with 2 type 4D arms with multi-directional movement, fixed with M8 bolts below R100S seat.

CODE 010702

**Sparco R100S Armchair** - This replica of a Sparco race car seat has a lower, wider seat for maximum comfort, the back reclines, there is adjustable lumbar support and a mechanism that stops it from tipping over by preventing the back from reclining by more than 150°. The Sparco armchair comes complete with a polished aluminium base, an SGS / BIFMAX5.1 / EN1335 certified piston, a rocking mechanism and 5 sturdy wheels. The arms are type 4D with multi-directional movement.



Rotating base with wheels, polished aluminium base with an SGS / BIFMAX5.1 / EN1335 certified piston, a rocking mechanism and 5 sturdy wheels, fixed with 8.5 mm holes on a 20 cm x 20 cm baseplate.

CODE 010801

# OFFICIAL COLLECTIONS

## AND LICENSING

SPARCO® leader of more than 40 years' standing on the world's of tracks, pursues excellence and shares its underlying values through special collections made directly, Teamwork and Gaming, or licensed by prestigious international partners. Quality, style and security are consecrated in new realities, from safety shoes to childhood protection, from car care to wheels, from the intriguing fashion industry to the virtual world of gamers.

## OFFICIAL COLLECTIONS

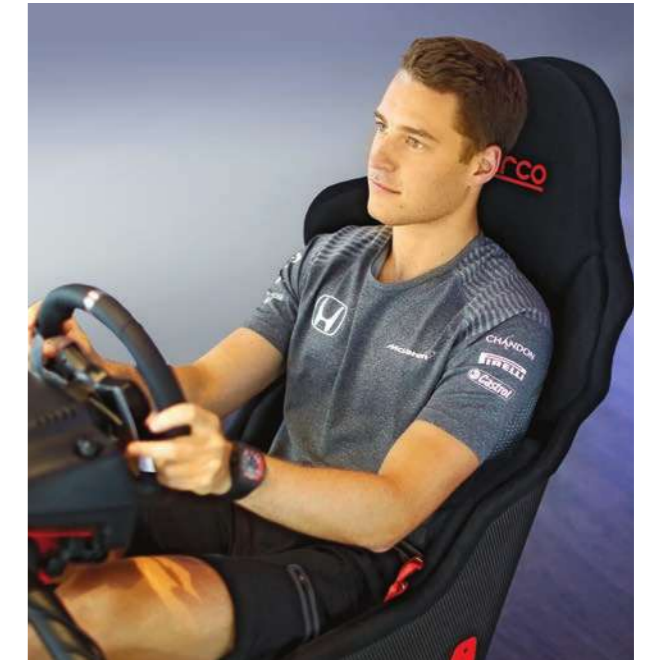

- Sparco Teamwork is the safety collection by SPARCO® designed to offer all consumers a Racing style range which is lightweight, comfortable and safe.
- High quality Footwear and products, manufactured in full compliance with current regulations on personal protective equipment. Safety, comfort and Italian Design, in unmistakable Racing style.

- SPARCO® Gaming is born to make the experience of the 'simulation' and gaming ever closer to reality. The collection aimed not only at the "casual" gamer, but also for the experienced user seeking high performance, such as eSports athletes. SPARCO® Gaming has conceived three gaming chair models, a cockpit Evolve; a glove Hypergrip, designed for use both with the steering wheels in various materials and with PC controllers and consoles and a t-shirt GT Vent, 100% customized.



by CAR PARTS DESIGN

#### CARPA DESIGN

- A collection of car accessories to enhance functionality, comfort and style off the tracks



by CAR PARTS DESIGN

#### CARPA DESIGN

- A collection of car seats designed to ensure maximum safety for the drivers of the future.



by CAR PARTS DESIGN

#### CARPA DESIGN

- A collection of car care and protection accessories for maximum performance and a dazzling style.



by OZ RACING



- A collection of high quality alloy wheels designed for the after-market industry and for the changing seasons, and all rigorously MADE IN ITALY.



by BRANDSDISTRIBUTION

- A unique collection of footwear and outerwear, and all rigorously MADE IN ITALY. Dedicated to those athletes who enjoy sporting an elegant "after race" look.



by SKG



- A collection of high-performing car and truck batteries, in true Sparco style.



by MODULA CS



- A collection of car roof boxes with an elegant finish and refined details.



by BHR HELMETS



- A collection of motorcycle helmets dedicated to all 2-wheeler enthusiasts seeking safety combined with a dynamic look in true Sparco style.

