

# SKYJACKER<sup>®</sup>

SUSPENSIONS

SKYJACKER<sup>®</sup>  
SUSPENSIONS  
*Shock Lines*



# SKYJACKER<sup>®</sup>

SUSPENSIONS



**Recently the National Highway Traffic Safety Administration (NHTSA) established the Federal Motor Vehicle Safety Standard (FMVSS) No. 126** requiring all new passenger vehicles under 10,000 lbs GVWR include an electronic stability control (ESC) system as standard equipment. FMVSS No. 126 tests new vehicle ESC systems through a series of evasive lane-change maneuvers at highway speeds to ensure the driver can maintain control in critical driving situations. The idea behind the mandate is to reduce the risk of rollover crashes among passenger vehicles. Effective August 2012 this law requires aftermarket products to be compliant with these same standards.

We have a number of our lift kits tested to prove compliance with the FMVSS 126 mandate. These tests measure with great accuracy how the vehicle reacts after modification and was done to ensure Skyjacker products work in harmony with the Electronic Stability Control (ESC). Through SEMA and the advanced testing by Link Engineering that involves robotic steering and outrigger equipment we have demonstrated our compliance with this safety standard and are proud to announce we have passed the rigorous FMVSS 126 physical testing.



# SKYJACKER SUSPENSIONS

# BLACKMAX

**Black MAX twin tube shock absorbers have increased fluid capacity and utilize “foam-cell” technology. When the shock is working hard and gets hot, the foam-cell insert compresses to compensate for oil expansion which maintains consistent MAX Performance throughout the operating temperature range of the shock. The foam-cell design also eliminates air inside the shock which allows for mounting in any direction. Arc-welded end mounts and select specific valving give the BlackMAX shock absorber MAX value.**

**360° Arc-Welded End Mount**

**StableSteer Valving**  
Improves tire contact with the road for safety and control.

**Increased Fluid Capacity and Advanced Foam-Cell**  
for MAX Heat Dissipation and MAX Fade Reduction.

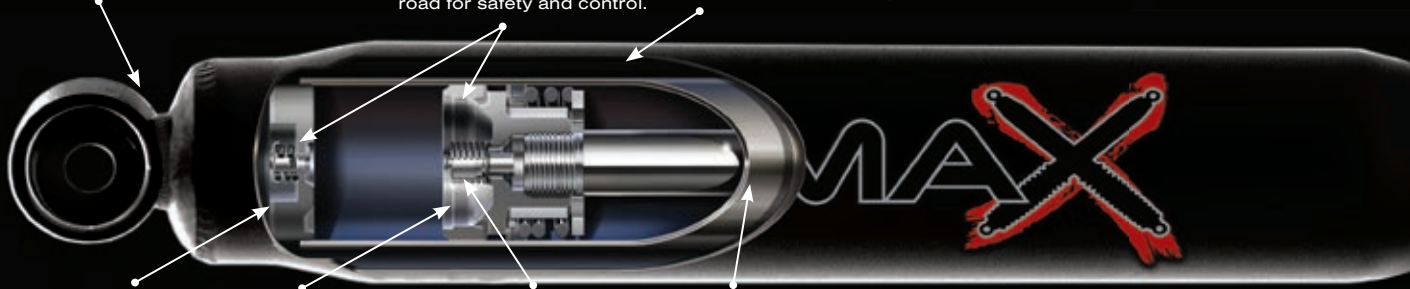

**Heavy Duty Compression Head**  
Reliable Performance Under Extreme Conditions.

**Sintered Iron Piston**  
Durability and Maximum Shock Performance.

**Orifice Control Disk**  
Consistent Control for Comfort and Stability.

**D.O.M. Tubing**  
Reduces Internal Wear for Longer Product Life.



- **Advanced Foam-Cell Technology**
- **Vehicle Specific Multi-Stage Valving**
- **Increased Fluid Capacity for MAX Heat Dissipation**
- **360° Arc-Welded End Mount**
- **180° Directional Mounting**
- **Twin Tube Construction**
- **Chrome Plated Shaft**
- **Sintered Iron Piston**
- **Black Boot Incl.**
- **Limited Lifetime Warranty**

# SKYJACKER

SUSPENSIONS

## Shock Lines

# SKYJACKER

SUSPENSIONS

PERFORMANCE MONOTUBES

### MONOTUBE M9500 FEATURES

- HIGH PRESSURE NITROGEN GAS CHARGED • CUSTOM TUNED FOR EACH VEHICLE
- MONOTUBE DESIGN • 180° DIRECTIONAL MOUNTING • LARGE 46MM BORE • CHROMED PISTON ROD
- NO FADE OR LAG FOR CONSTANT PERFORMANCE • LIMITED LIFETIME WARRANTY

# SKYJACKER

BLACKMAX

### Black MAX B8500 FEATURES

- ADVANCED FOAM-CELL TECHNOLOGY • VEHICLE SPECIFIC MULTI-STAGE VALVING
- INCREASED FLUID CAPACITY FOR MAX HEAT DISSIPATION • 360° ARC-WELDED END MOUNT
- 180° DIRECTIONAL MOUNTING • TWIN TUBE CONSTRUCTION • CHROME PLATED SHAFT
- SINTERED IRON PISTON • BLACK BOOT INCL. • LIMITED LIFETIME WARRANTY

# SKYJACKER

NITRO 8000

### NITRO N8000 FEATURES

- 150 PSI PRESSURIZED NITROGEN GAS • ORIFICE DISK • VELOCITY SENSITIVE VALVING
- LEAK PROOF SEAL • BONDED IRON PISTON • CHROMED PISTON ROD • RED BOO
- RED POLYURETHANE BUSHINGS • LIMITED LIFETIME WARRANTY

# SKYJACKER

HYDRO 7000

### HYDRO H7000 FEATURES

- HYDRAULIC ACTION • ORIFICE DISK • VELOCITY SENSITIVE VALVING
- LEAK PROOF SEAL • BONDED IRON PISTON • CHROMED PISTON ROD • RED BOO
- RED POLYURETHANE BUSHINGS • LIMITED LIFETIME WARRANTY





# Steering Stabilizers

**Skyjacker® Steering Stabilizer** A steering stabilizer is a dampening shock for your steering system. It dampens out the harshness of the highway, the 'shimmy' from running the additional weight of larger tires & wheels and places control back into the driver's hands. Stabilizers also reduce the fatigue of the driver on a personal level by reducing the amount of physical strength it takes to guide those larger tires on and off the road. Changing the weak stock unit for a better performing replacement or adding dual steering stabilizers is an inexpensive but worthy investment.



### Replacement Shock Boots

Skyjacker® offers replacement shock boots in a variety of colors.



**Skyjacker's adjustable lower control arms for Jeep JK** feature a vulcanized rubber bushing at the frame and flex joints at the axle. The vulcanized rubber bushing provide superior vibration dampening, while the Currie Johnny Joint<sup>®</sup> provides 30 degrees of misalignment. You can rest assured we have the right components to give you the most articulation! Skyjacker<sup>®</sup> Flex Joints features a bushing that is made with a high density tough 88 urethane that encases the inner ball. This durable material stands up in all weather conditions! The special ball insert is heat treated steel which offers unparalleled strength. The joint is lubricated with a zerk fitting on the outer shell and the outer shell is also heat treated steel. The retaining washers in the rod end are machined out of 4340 chrome moly and feature a snap ring safety machined into the face of them to protect the snap ring from coming out.

This new combination of a rubber bushing which provides a smooth quiet ride on the street and the rock solid reputation of the Currie Johnny joint will give you peace of mind out on the trail and in any terrain.



# SKYJACKER<sup>®</sup> SUSPENSIONS Product Features

## SOFTTRIDE<sup>®</sup> LEAF SPRINGS Featured in Systems

Skyjacker<sup>®</sup> Softride<sup>®</sup> springs are individually shot-peened with hard steel pellets at very high velocities. This shot-peening compresses the surface of the steel thereby increasing the tensile strength of the spring. Without this shot-peening procedure, the maximum wheel travel and ride quality could not be achieved without sacrificing the life of the spring. Softride<sup>®</sup> springs use 'bolt' style spring clips, eliminating friction. Other spring designs use the 'cinch' style bend clips which bend tightly over the spring leaves causing binding and friction. Skyjacker<sup>®</sup> Softride<sup>®</sup> springs are a tapered spring creating more flex at the leaf ends. This tapering distributes loads more evenly over a greater area and reduces the tendency for one leaf to dig into the leaf above it. Rear Softride<sup>®</sup> springs are used to complete the 'SYSTEM' in a Skyjacker<sup>®</sup> suspension lift.



## BLOCKS AND U-BOLTS Featured in Kits

The Skyjacker<sup>®</sup> U-Bolts are e-coated for corrosion resistance. These U-Bolts are offered in various shapes and sizes such as square, round, and semi-round in lengths ranging from 1.75" - 19". The Blocks used in Skyjacker<sup>®</sup> Kits are Ductile iron with fixed center pins. They are also tapered to correct pinion angle and prevent driveline vibrations. Available in 1.25, 2, 3.5, 4.5 & 5.5 inches. Rear Block & U-Bolt Kits are usually used to make a 'KIT' in a Skyjacker<sup>®</sup> suspension lift. But a 'KIT' could also be a combination of Blocks & U-Bolts or Add-a-Leafs.

### SKYJACKER<sup>®</sup> BLOCKS

• Ductile iron • Fixed Center Pin • Tapered



## ADD-A-LEAFS SPRINGS Featured in Kits

Skyjacker<sup>®</sup> offers a diverse selection of front and rear Add-a-Leafs. Skyjacker<sup>®</sup> Add-A-Leafs insert directly into your factory leaf spring providing lift and added strength. Softride<sup>®</sup> Add-a-Leafs are shot-peened with hard steel pellets at very high velocities. This shot-peening compresses the surface of the steel thereby increasing the tensile strength of the leaf. Without this shot-peening procedure, the maximum wheel travel and ride quality could not be achieved without sacrificing the life of the leaf. The Skyjacker<sup>®</sup> Add-a-Leafs are pre-drilled for the center pin. Pin location varies with each application. Most have long tapered ends for a progressive affect and ride comfort. Rear Add-A-Leafs are sometimes used to make a 'KIT' in a Skyjacker<sup>®</sup> suspension lift. But it could also be a combination of Blocks & U-Bolts AND Add-a-Leafs.



## SKYJACKER<sup>®</sup> STEERING COMPONENTS

Skyjacker<sup>®</sup> knows the importance of steering correction after lifting a vehicle and we have an extensive line of steering components to prove it. From drag links to a variety of steering arms, Skyjacker<sup>®</sup> has the steering components to steer you straight.



## SKYJACKER® SPACER KITS

Spacer Kits are in high demand and produce optimum results for the amount of money spent. Specifically designed for an array of vehicles, these Spacer Kits add 2-2.5" of lift to the struts or coil springs. Skyjacker® offers Poly Value Kits with polyurethane spacers & powder coated steel fabricated units like for the Honda Ridgeline. They include all the parts & hardware necessary to bolt-on this simple, but effective lift. No cutting or welding is involved and standard tools get the job done.



## ASSORTED POLYURETHANE

Skyjacker® carries a very large line of Polyurethane products to fit your vehicle's needs. The list includes Bump Stops, Bushings, Cab Mount Kits, Clearance Kits, and an array of Bushings (Spring Eye, Frame Shackle, Radius Arm, Track Bar, Caster) for various applications, makes and models. Polyurethane is a superior material that has a higher load-bearing capacity and can better resist the dynamic torque-like twisting and turning forces of suspension components as they go through their normal operation/travel movements. It is also an improved sound/vibration dampening material.

## STAINLESS STEEL BRAIDED BRAKELINES

Skyjacker® has gone to 'extended lengths' to accommodate our four wheeling friends and to improve your 4x4s braking performance. All have been tried and tested in some of the most severe conditions four wheeling has to offer in virtually every corner of the world. They all passed the test and are proven in their quality of engineering, workmanship and finish. Skyjacker® brake lines conform to all federal requirements of FMVSS106, making them D.O.T. Certified and T.U.V. Approved in Germany.



## STEERING STABILIZERS

A steering stabilizer is a dampening shock for your steering system. It dampens out the harshness of the highway, the 'shimmy' from running the additional weight of larger tires & wheels and places control back into the driver's hands.

Stabilizers also reduce the fatigue of the driver on a personal level by reducing the amount of physical strength it takes to guide those larger tires on and off the road. Changing the weak stock unit for a better performing replacement or adding dual steering stabilizers is an inexpensive but worthy investment.

## JEEP CONTROL ARMS \ LINKS

**Standard Link Control arms** are fitted with rubber bushings (RB) on both ends of each link. **Value Flex Control arms** are fitted with greasable polyurethane bushings on one end and a NG rebuildable rod end on the other. **Rock Ready® Series long arm links** are 80% longer than stock, fitted with NG rebuildable rod ends with "Pivot Plus" inserts for maximum rotation.



Rock Ready® Long Arm



# JL



**2018 JL DUAL RATE-LONG TRAVEL** suspension offers you the best of both worlds! Dual Rate means the 1st Rate offers both an exceptional highway ride & LONG TRAVEL as those coils EXPAND during articulation which allows suspension droop to keep the tires in the contact with the ground much longer. The 2nd Rate, lower coils, only engage when the suspension compresses past the 1st rate. The 2nd rate allows consistent control & stability during heavy off-road suspension movement.



1-1.5" Dual Rate Long Travel



2-2.5" Dual Rate Long Travel



3.5-4" Dual Rate Long Travel

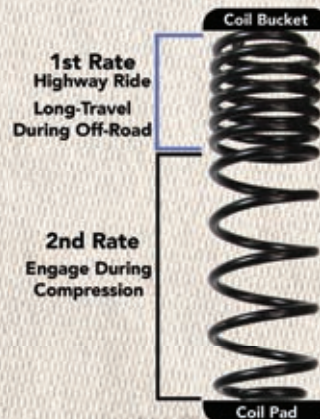

## 2018 Wrangler JL 4 Door 4WD (Rubicon & NON-Rubicon Models)

Kit Ref #	Description	Qty	Part #	
<b>WRANGLER JL 4 Door 4WD Polyurethane Spacer &amp; Value Kits (Rubicon &amp; NON-Rubicon Models)</b>				
JLFPS75	3/4" Front Poly Spacer		JLFPS75	
JLRPS75	3/4" Rear Poly Spacer		JLRPS75	
JL20	2" Front & 2" Rear Poly Value Kit		JL20	
<b>WRANGLER JL 4 Door 4WD Dual Rate Long Travel (NON-Rubicon Models)</b>				
JL15BPBLT	1-1.5" Dual Rate Long Travel Coil Springs & Shocks, includes (4) Long Travel Black MAX Shocks	1	JL15BPBLT	
JL15BPMLT	1-1.5" Dual Rate Long Travel Coil Springs & Shocks, includes (4) Long Travel M95 Shocks	1	JL15BPMLT	
<b>WRANGLER JL 4 Door 4WD Dual Rate Long Travel (RUBICON Models)</b>				
JL15RBPBLT	1-1.5" Dual Rate Long Travel Coil Springs & Shocks, includes (4) Long Travel Black MAX Shocks	1	JL15RBPBLT	
JL15RBPMLT	1-1.5" Dual Rate Long Travel Coil Springs & Shocks, includes (4) Long Travel M95 Shocks	1	JL15RBPMLT	
<b>WRANGLER JL 4 Door 4WD Dual Rate Long Travel (NON-Rubicon Models)</b>				
JL25BPBLT	2-2.5" Dual Rate Long Travel Coil Springs & Shocks, includes (4) Long Travel Black MAX Shocks	1	JL25BPBLT	
JL25BPMLT	2-2.5" Dual Rate Long Travel Coil Springs & Shocks, includes (4) Long Travel M95 Shocks	1	JL25BPMLT	
<b>WRANGLER JL 4 Door 4WD Dual Rate Long Travel (RUBICON Models)</b>				
JL25RBPBLT	2-2.5" Dual Rate Long Travel Coil Springs & Shocks, includes (4) Long Travel Black MAX Shocks	1	JL25RBPBLT	
JL25RBPMLT	2-2.5" Dual Rate Long Travel Coil Springs & Shocks, includes (4) Long Travel M95 Shocks	1	JL25RBPMLT	
<b>WRANGLER JL 4 Door 4WD Dual Rate Long Travel (NON-Rubicon Models)</b>				
JL40BPBLT	3.5-4" Dual Rate Long Travel Coil Springs & Shocks, includes (4) Long Travel Black MAX Shocks	1	JL40BPBLT	
JL40BPMLT	3.5-4" Dual Rate Long Travel Coil Springs & Shocks, includes (4) Long Travel M95 Shocks	1	JL40BPMLT	
<b>WRANGLER JL 4 Door 4WD Dual Rate Long Travel (RUBICON Models)</b>				
JL40RBPBLT	3.5-4" Dual Rate Long Travel Coil Springs & Shocks, includes (4) Long Travel Black MAX Shocks	1	JL40RBPBLT	
JL40RBPMLT	3.5-4" Dual Rate Long Travel Coil Springs & Shocks, includes (4) Long Travel M95 Shocks	1	JL40RBPMLT	
Wrangler JL Options	OEM HD Replacement Steering Damper - White	1	7008	<b>NEW!</b>
	OEM HD Replacement Steering Damper - Black	1	8008	<b>NEW!</b>
	OEM HD Replacement Steering Damper - Silver	1	9008	<b>NEW!</b>
	Dual Steering Damper Kit - White	1	7208	<b>NEW!</b>
	Dual Steering Damper Kit - Black	1	8208	<b>NEW!</b>
	Dual Steering Damper Kit - Silver	1	9208	<b>NEW!</b>
	Heavy Duty Front & Rear Lower Links - Set	1	JL24LL	<b>NEW!</b>
	Single Flex Front & Rear Lower Links - Set	1	JL24LLX	<b>NEW!</b>
	Single Flex Front Lower Links - Pair	1	JLL24F-SX	<b>NEW!</b>
	Single Flex Rear Lower Links - Pair	1	JLL24R-SX	<b>NEW!</b>
	Single Flex Front Upper Links - Pair	1	JLULF26-SX	<b>NEW!</b>
Single Flex Rear Upper Links - Pair	1	JLULR26-SX	<b>NEW!</b>	



JL24LLX

# JK



## Skyjacker® LeDuc Series Features & Benefits

- Direct bolt on
  - Returnable to stock
  - Adjustable ride height
  - Increased articulation
  - Adjustable secondary spring rate engagement
  - Vehicle specific tuned shocks
  - Improved stability
  - Optional air bump stops
  - Made in the USA
  - Lifetime guaranteed coil spring
- Purchased as kit or coil-over box upgrade for current Skyjacker® Suspension!

**Skyjacker® is proud to announce our new bolt in Skyjacker® LeDuc Series coil-overs that are tuned and tested by Curt LeDuc with application specific valving for maximum performance on and off-road. This new series of coil-overs can be purchased as kit or just get the coil-over box upgrade for your current Skyjacker® Suspension!**

4.5" -6" Curt LeDuc Coil Over Kits with Lower Arms Jeep 2DR & 4DR Wrangler & Unlimited 2007-18 - Suggested Tire Size 33" - 37"				
<b>JK60SLSK-SX</b>	Wrangler JK Front Coil-Over Shocks & Coil-Over Spring Box	1	JK62FLS	4,5,6,7
	Wrangler JK Front Coil-Over Component Box	1	JK62FLSB	
	Rear Coil-Over Shocks & Coil Spring Box	1	JK62RLS	
	Rear Coil-Over Component Box	1	JK62RLSB	
	Front & Rear Adjustable Lower Flex Control Arm Links w/Currie Rod Ends 2.5-4" Lift	1	JK24LLX	
	Front Adjustable Track Bar 0-7"	1	JKFTBA717	
3.5" -4.5" Curt LeDuc Coil Over Kits with Lower Arms Jeep 2DR & 4DR Wrangler & Unlimited 2007-18 - Suggested Tire Size 33" - 37"				
<b>JK40SLSK-SX</b>	Wrangler JK Front Coil-Over Shocks & Coil-Over Spring Box	1	JK62FLS	4,5,6,7
	Wrangler JK Front Coil-Over Component Box	1	JK62FLSB	
	Rear Coil-Over Shocks & Coil Spring Box	1	JK62RLS	
	Rear Coil-Over Component Box	1	JK42RLSB	
	Front & Rear Adjustable Lower Flex Control Arm Links w/Currie Rod End 2.5-4" Lift	1	JK24LLX	
	Front Adjustable Track Bar 2-7"	1	JKFTBA717	
4.5" -6" Curt LeDuc Long Arm Coil Over Kits Jeep 2DR & 4DR Wrangler & Unlimited 2007-18 - Suggested Tire Size 33" - 37"				
<b>JK64LLSK-SX</b>	Wrangler JK Front Coil-Over Shocks & Coil-Over Spring Box	1	JK62FLS	4,5,6,7
	Wrangler JK Front Coil-Over Component Box	1	JK62FLSB	
	Rear Coil-Over Shocks & Coil Spring Box	1	JK62RLS	
	Rear Coil-Over Component Box	1	JK62RLSB	
	Wrangler JK Long Arm Box 4-7"	1	JK46LA-SX	
	Front Adjustable Track Bar 0-7"	1	JKFTBA717	
3.5" -4.5" Curt LeDuc Long Arm Coil Over Kits Jeep 2DR & 4DR Wrangler & Unlimited 2007-18 - Suggested Tire Size 33" - 37"				
<b>JK44LLSK-SX</b>	Wrangler JK Front Coil-Over Shocks & Coil-Over Spring Box	1	JK62FLS	4,5,6,7
	Wrangler JK Front Coil-Over Component Box	1	JK62FLSB	
	Rear Coil-Over Shocks & Coil Spring Box	1	JK62RLS	
	Rear Coil-Over Component Box	1	JK42RLSB	
	Wrangler JK Long Arm Box 4-7"	1	JK46LA-SX	
	Front Adjustable Track Bar 2-7"	1	JKFTBA717	
<b>Notes</b>	4) Steering Stabilizers available to match all shock colors 5) Exhaust Spacer/Modification JK36ESK required 2012-17 6) 2 Door Models require After market CV Driveshaft 7) 2 Door Models may require Rear Upper Adjustable Control Arms JKULR26-SX			
<b>Options</b>	Optional Front Air Bump Stop	1	JKLSAB	
	Optional Rear Air Bump Stop	1	JKLSABR	



# JK



With diversity in New Jeep ownership it is no surprise to find Jeep Wrangler JK is sporting a softer rate spring for a softer ride. With this Skyjacker® has created Softride® Coil Kits to maintain OE ride of newer models while still meeting the challenges of off-road terrain of the preceding Rock Ready® Coils.

## Jeep Wrangler 2 Door & 4 Door - 2WD & 4WD 2007-2018

Kit Ref #	Description	Qty	Part #	Front Shock	Rear Shock	Note
<b>2" Front, 2" Rear Poly Spacer Kit Jeep 2DR &amp; 4DR Wrangler / Wrangler Unlimited 2007-18 - Suggested Tire Size 33" - 34"</b>						
JK20	2" Lift Poly Spacer Kit, Choose Shocks	1	JK20			
	<b>Select Shock Option F&amp;R Shocks (2) each of desired Series</b>					
	<b>Hydro Series Shock with Red Boot, White</b>	2		H7035	H7037	4
	<b>Nitro Series Gas Shock with Red Boot, White</b>	2		N8035	N8037	4
	<b>Black MAX Performance Shock with Black Boot, Black</b>	2		B8535	B8537	4
<b>M95 Monotube Performance Shock, Silver</b>	2		M9535	M9537	4	
<b>2" Front, 3/4" Rear Poly Spacer Leveling Kit Jeep 2DR &amp; 4DR Wrangler / Wrangler Unlimited 2007-18 - Suggested Tire Size 33" - 34"</b>						
JK23	2" Front, 3/4" Rear Lift Poly Spacer Kit, Choose Shocks	1	JK23			
	<b>Select Shock Option F&amp;R Shocks (2) each of desired Series</b>					
	<b>Hydro Series Shock with Red Boot, White</b>	2		H7035	H7037	4
	<b>Nitro Series Gas Shock with Red Boot, White</b>	2		N8035	N8037	4
	<b>Black MAX Performance Shock with Black Boot, Black</b>	2		B8535	B8537	4
<b>M95 Monotube Performance Shock, Silver</b>	2		M9535	M9537	4	



Skyjacker's popular One Box everything included 3.5" 2 Door 4" 4 Door Jeep Wrangler JK kits just got even better. Skyjacker improved on the design now including an Adjustable Track Bar. This results in improved geometry and reduced cost no longer requiring the purchase of a pitman arm.

Jeep Wrangler 2 Door & 4 Door - 2WD & 4WD 2007-2018				
Kit Ref #	Description	Qty	Part #	Note
<b>2" Softride® Kits Jeep 2DR Wrangler 2007-18 - Suggested Tire Size 33"- 34"</b>				
JK200BPHSR	2" Softride®, includes (4) Hydro shocks		JK200BPHSR	2,4
JK200BPNSR	2" Softride®, includes (4) Nitro shocks		JK200BPNSR	2,4
JK200BPBSR	2" Softride®, includes (4) Black MAX shocks		JK200BPBSR	2,4
JK200BPMSR	2" Softride®, includes (4) M95 shocks		JK200BPMSR	2,4
<b>3.5" Softride® Kits Jeep 2DR Wrangler 2007-18 JK - Suggested Tire Size 34"- 35"</b>				
JK350BPHSR	3.5" Softride®, Complete Kit, includes (4) Hydro shocks & ADJUSTABLE FRONT TRACK BAR	1	JK350BPHSR	2,3,4,5
JK350BPNSR	3.5" Softride®, Complete Kit, includes (4) Nitro shocks & ADJUSTABLE FRONT TRACK BAR	1	JK350BPNSR	2,3,4,5
JK350BPBSR	3.5" Softride®, Complete Kit, includes (4) Black MAX shocks & ADJUSTABLE FRONT TRACK BAR	1	JK350BPBSR	2,3,4,5
JK350BPMSR	3.5" Softride®, Complete Kit, includes (4) M95 Monotube shocks & ADJUSTABLE FRONT TRACK BAR	1	JK350BPMSR	2,3,4,5
<b>2.5" Softride® Kits Jeep 4DR Wrangler Unlimited 2007-18 - Suggested Tire Size 33"- 34"</b>				
JK25BPHSR	2.5" Lift Softride®, Complete Kit, includes (4) Hydro shocks	1	JK25BPHSR	2
JK25BPNSR	2.5" Lift Softride®, Complete Kit, includes (4) Nitro shocks	1	JK25BPNSR	2
JK25BPBSR	2.5" Lift Softride®, Complete Kit, includes (4) Black MAX shocks	1	JK25BPBSR	2,4
JK2500BPMSR	2.5" Lift Softride®, Complete Kit, includes (4) M95 Monotube	1	JK2500BPMSR	2
<b>4" Softride® Kits 4DR Jeep Wrangler Unlimited 2007-18 - Suggested Tire Size 34"- 37"</b>				
JK40BPHSR	4" Lift Softride®, Complete Kit, includes (4) Hydro shocks & ADJUSTABLE FRONT TRACK BAR	1	JK40BPHSR	2,3,4,5
JK40BPNSR	4" Lift Softride®, Complete Kit, includes (4) Nitro shocks & ADJUSTABLE FRONT TRACK BAR	1	JK40BPNSR	2,3,4,5
JK40BPBSR	4" Lift Softride®, Complete Kit, includes (4) Black MAX shocks & ADJUSTABLE FRONT TRACK BAR	1	JK40BPBSR	2,3,4,5
JK400BPMSR	4" Lift Softride®, Complete Kit, includes (4) M95 Monotube & ADJUSTABLE FRONT TRACK BAR	1	JK400BPMSR	2,3,4,5
Notes	2) Control Arm Upgrades - Heavy Duty Lower Links add JKLL24, Adjustable Lower Flex Links add JK24LLX 3) Long Arm Upgrade add JK46LA-SX 4) Steering Stabilizers available to match 5) Exhaust Spacer/Modification JK36ESK required 2012-18 Models			
Additional Jeep applications available. See pages 158-175.				



**JK350BPHSR / JK40BPHSR**  
Includes Adjustable Front Track Bar



**JK20**



**JK2500BPMSR**



## Jeep Wrangler 2 Door & 4 Door - 2WD & 4WD 2007-2018

Kit Ref #	Description	Qty	Part #	Front Shock	Rear Shock	Note	
<b>4" 4 Door - 5" 2 Door Rock Ready Long Arm Kit Jeep Wrangler / Unlimited JK Suggested Tire Size 35" - 37"</b>							
<b>JK40LAK-SX</b>	Wrangler JK Long Arm Box 4-7"	1	JK46LA-SX				
	Wrangler JK Long Arm Box 4-5"	1	JK40LA				
	Wrangler JK Rock Ready Front Coils 4-5"	1	JK40F				
	Wrangler JK Rock Ready Rear Coils 4-5"	1	JK40R				
	<b>Required Pitman Arm Jeep JK</b>	1	JA770				
	<b>Select a Shock Option F&amp;R Shocks (2) each of desired Shock Series</b>						
	<b>Hydro Series Shock with Red Boot, White</b>	2		H7065	H7067	4	
	<b>Nitro Series Gas Shock with Red Boot, White</b>	2		N8065	N8067	4	
	<b>Black MAX Performance Shock with Black Boot, Black</b>	2		B8565	B8567	4	
	<b>M95 Monotube Performance Shock, Silver</b>	2		M9565	M9567	4	
<b>6" 4 Door - 7" 2 Door Rock Ready Long Arm Kit Jeep Wrangler / Unlimited JK Suggested Tire Size 36" - 38"</b>							
<b>JK60LAK-SX</b>	Wrangler JK Long Arm Box 4-7"	1	JK46LA-SX				
	Wrangler JK Long Arm Box 4-5"	1	JK60LA				
	Wrangler JK Rock Ready Front Coils 4-5"	1	JK60F				
	Wrangler JK Rock Ready Rear Coils 4-5"	1	JK60R				
	<b>Required Pitman Arm Jeep JK</b>	1	JA770				
	<b>Select a Shock Option F&amp;R Shocks (2) each of desired Shock Series</b>						
	<b>Hydro Series Shock with Red Boot, White</b>	2		H7075	H7087	4	
	<b>Nitro Series Gas Shock with Red Boot, White</b>	2		N8075	N8087	4	
	<b>Black MAX Performance Shock with Black Boot, Black</b>	2		B8575	B8587	4	
	<b>M95 Monotube Performance Shock, Silver</b>	2		M9575	M9587	4	
<b>Notes</b>	<b>2) Control Arm Upgrades - Heavy Duty Lower Links add JKLL24, Adjustable Lower Flex Links add JK24LLX 3) Long Arm Upgrade add JK46LA-SX 4) Steering Stabilizers available to match 5) Exhaust Spacer/Modification JK36ESK required 2012-18 Models 6) 2 Door Models require After market CV Driveshaft 7) 2 Door Models require Upper Adjustable Control Arms JKULR26-SX 8) Requires Adjustable Front Track Bar JKFTBA717 9) Requires Front &amp; Rear Adjustable Lower Control JK24LLX</b>						

Additional Jeep applications available. See pages 158-175.



**JK40LAK-SX  
JK60LAK-SX**



**Options Jeep Wrangler & Wrangler & Unlimited 2007-2018**

<b>JK62FLSBO</b> (JK Front Coil-Over Upgrade 3.5-6")	Wrangler JK Front Coil-Over Upgrade Shocks & Coil-Over Spring Box	1	JK62FLS	8,9
	Wrangler JK Front Coil-Over Upgrade Component Box	1	JK62FLSB	8,9
<b>JK42RLSBO</b> (3.5-4.5" JK Rear Coil-Over Upgrade)	Wrangler JK Rear Coil-Over Upgrade Shocks & Coil-Over Spring Box	1	JK62RLS	6,7
	Wrangler JK Rear Coil-Over Upgrade Component Box	1	JK42RLSB	6,7
<b>JK62RLSBO</b> (4.5-6" JK Rear Coil-Over Upgrade)	Wrangler JK Rear Coil-Over Upgrade Shocks & Coil-Over Spring Box	1	JK62RLS	6,7
	Wrangler JK Rear Coil-Over Upgrade Component Box	1	JK62RLSB	6,7
<b>Wrangler JK Options</b>	<b>Spare Tire Relocation Kit</b>	1	STRJK212	<b>NEW!</b>
	<b>Spare Tire Support Kit (See page 18-19)</b>	1	TGSJK1	
	<b>Combo Relocation &amp; Support Kit (Includes STRJK212 &amp; TGSJK1)</b>	1	TGSSTR1	
	<b>Heavy Duty DUAL LOAD Ball Joint Kit (See page 21)</b>	1	JK2717B	<b>NEW!</b>
	<b>Front &amp; Rear Heavy Duty Lower Control Arm Links 2.5-5" Lift</b>	1	JKLL24	
	<b>Front &amp; Rear Adjustable Lower Flex Control Arm Links w/ Flex Rod Ends 2.5-6" Lift</b>	1	JK24LLX	
	<b>Long Arm Upgrade 3.5-6" Lift Long Arm Upgrade 3.5-6" Lift</b>	1	JK46LA-SX	
	<b>Front Upper Adjustable Control Arms, 2-6" lift</b>	1	JKULF26-SX	
	<b>Rear Upper Adjustable Control Arms, 2-6" lift</b>	1	JKULR26-SX	
	<b>Front Adjustable Track Bar 0-7"</b>		JKFTBA717	
	<b>Rear Adjustable Track Bar 2-7"</b>	1	JKRTBA717	
	Dual Steering Stabilizer Kit, <b>WHITE</b>	1	7203 or 7204	
	Dual Steering Stabilizer Kit, <b>Black Max</b>	1	8203 or 8204	
	Dual Steering Stabilizer Kit, <b>SILVER</b>	1	9203 or 9204	
	OEM Steering Stabilizer Kit, <b>WHITE</b> w/Red Boot	1	7003	
	OEM Steering Stabilizer Kit, <b>Black Max</b> w/Black Boot	1	8003	
	OEM Steering Stabilizer Kit, <b>SILVER</b> w/Black Boot	1	9003	
	<b>Front Coil Spring Isolator Pads 3/4", Pair</b>		JKFPS75	
	<b>Rear Coil Spring Isolator Pads 3/4", Pair</b>		JKRPS75	
	<b>Grab Handles, 3" BLACK</b>		RRGH30RP-K	
<b>Grab Handles, 3" RED</b>		RRGH30RP-R		
<b>Control arm Cam Bolt Kit pair</b>		CAM700		
<b>Optional Front Air Bump Stop</b>		JKLSAB		

Additional Jeep applications available. See pages 158-175.



JKFTBA717



JK717DL



JK24LLX



JK717TR



# SKYJACKER<sup>®</sup> SUSPENSIONS

## Spare Tire Support Relocation Kit



Part # TGSJK1



Combo Kit # TGSSTR1





## Skyjacker Tailgate Saver Vibration Results Comparison

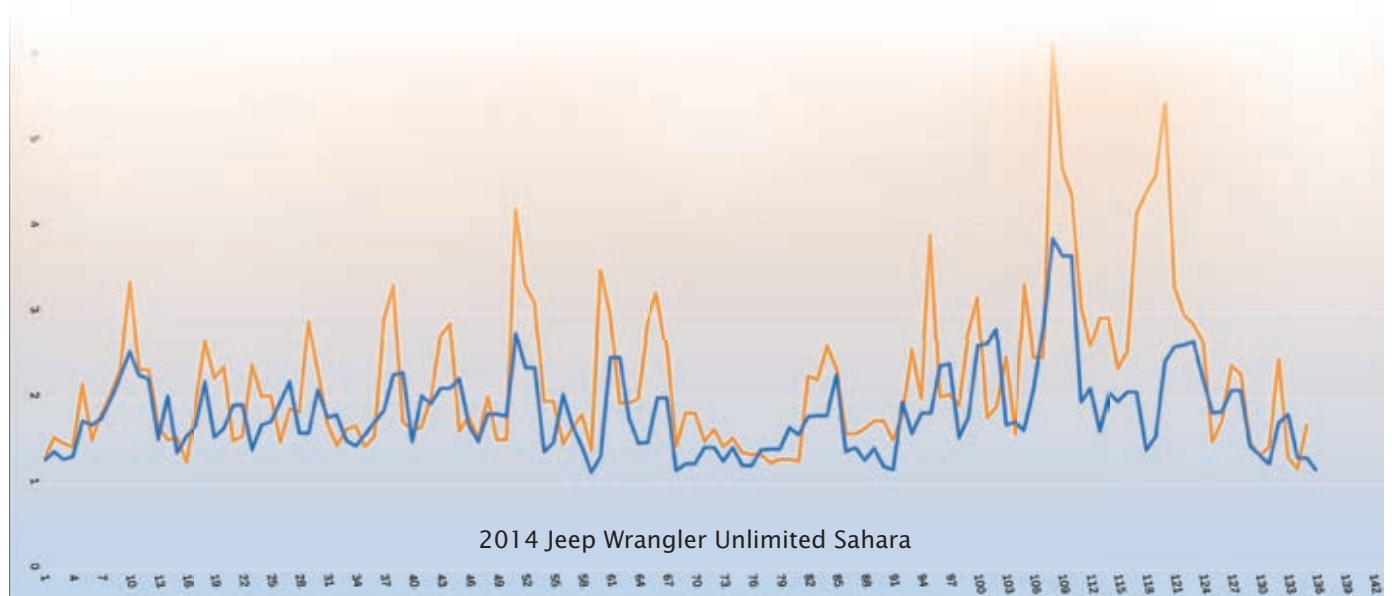

**Without  
Tailgate Saver**

**With  
Tailgate Saver**

- Supports Spare Tire Reducing Vibration and Noise
- Reducing Load and Force on Tailgate to Prevent Cracking
- Engineered to Work with Existing Tailgate Using Spare Tire Adapter/Spacer
- Works with Factory Rear Bumper and Many Aftermarket Rear Bumpers
- Works with and without Trailer Hitch or Tow Hook
- Completely Adjustable for 33"-38" Tires and Wheel Backspacing of 4"-5.5"
- Easy Installation Uses Existing Holes and Requires No Drilling
- Powder Coated Black with Stainless Hardware and Anti-Friction Wear Pad



## The Skyjacker® Rock Ready® heavy duty tie rod and drag link system



The Skyjacker® Rock Ready® heavy duty steering system for all Jeep Wrangler JK models features 1 3/4" diameter .281 wall 1026 DOM tie rod and drag link tubes, 1 1/4" threaded forged steel greasable tie rod ends, as well as a new steering stabilizer bracket. The massive tie rod cartridges thread into the tie rod end body, so they may be replaced without purchasing the entire rod end which saves cost. The same threaded tie rod cartridge is used at all 4 points so only one spare would have to be carried. Tie rod and drag link tubes feature wrench flats machined into them for ease of adjustment. This unit is a direct replacement for the OEM parts. No modifications or machining to any part of the vehicle is necessary. Tie rod and drag links can be purchased as a set or individually.

If a flipped draglink is desired, the tie rod cartridge may be unscrewed from the rod end body and screwed in from the other side. **NOTE: Flipping the drag link will require retapering the tie rod end hole from the top side of the knuckle.**

MADE IN THE USA



## Skyjacker® Rock Ready® ball joint load distribution design



**JK2717B**  
**JD302B**

**Upper Ball Joint**, USA-made tapered roller bearing carries axial and radial loads. Polyurethane wipe seal prevents contamination - mounted internally to prevent tearing and friction between knuckle and ball joint face

**Lower Ball Joint**, HEXAD Grease System - 6 equally spaced grease grooves evenly distributes grease; With every turn of the wheel, grease is spread in between the two wear surfaces

**32MM** powdered metal bearing replaces the undersized OE plastic bearing, increasing load carrying capacity

**Allows clearance** for RCV axles without modification

**MADE IN THE USA**

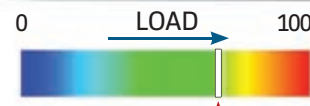
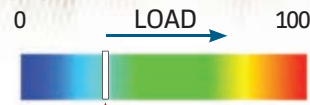

The Skyjacker® Rock Ready® ball joint design shares the load between both the lower and upper ball joints significantly lengthening the life of both joints.

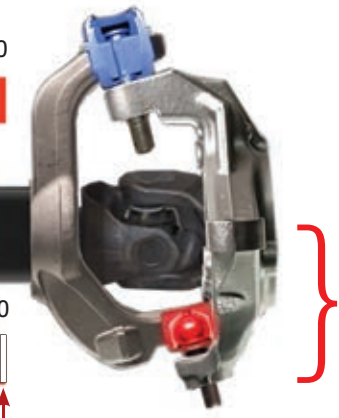

The OE ball joint design consist of a weight carrying lower ball joint and a follower upper ball joint. In this design the lower ball joint carries the full weight and road force of the Jeep and the upper ball joint is only a pivot point that controls lateral movement.

### Heavy Duty Load Carrying Upper Ball Joint

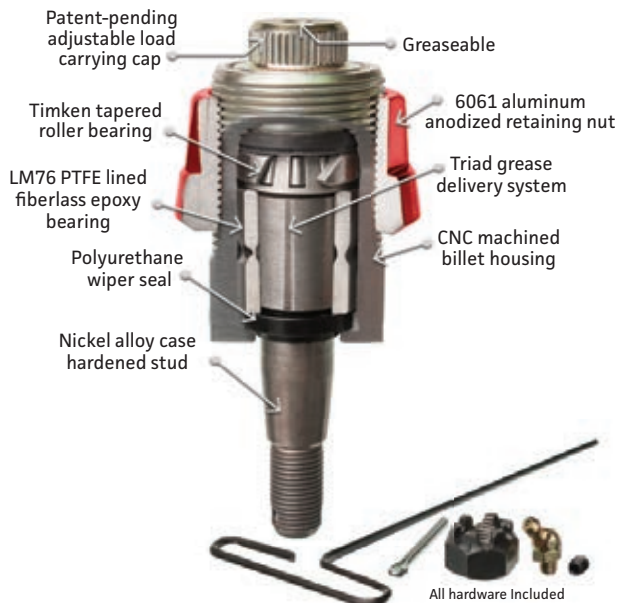

### Heavy Duty Lower Ball Joint



# TJ



**NEW!**  
**JD302B**

## Jeep Wrangler TJ 1997-2006

Kit Ref #	Description	Qty	Part #	Front Shock	Back Shock	Note
<b>2" Poly Spacer Kit Jeep Wrangler TJ &amp; Wrangler Unlimited LJ 1997-06 - Suggested Tire Size - 32"</b>						
TJ20	2" Kit Poly Spacer Kit Front & Rear	1	TJ20			
	<b>Select a Shock Option F&amp;R Shocks (2) each of desired Shock Series</b>					
	Hydro Series Shock with Red Boot, <b>White</b>	2		H7016	H7018	
	Nitro Series Gas Shock with Red Boot, <b>White</b>	2		N8016	N8018	
	Black MAX Performance Shock with Black Boot, <b>Black</b>	2		B8516	B8518	
M95 Monotube Performance Shock, <b>Silver</b>	2		M9516	M9518		
<b>2.5" Kit No Lower Link Arms Jeep Wrangler TJ &amp; Wrangler Unlimited LJ 1997-06 - Suggested Tire Size - 31"-32"</b>						
TJ25BPH	2.5" Jeep Wrangler, <b>includes (4) Hydro shocks</b>	1	TJ25BPH	Incl.	Incl.	
<b>3" Kit No Lower Link Arms Jeep Wrangler TJ &amp; Wrangler Unlimited LJ 1997-06 - Suggested Tire Size - 31"-33"</b>						
TJ30BPH	3" Jeep Wrangler, <b>includes (4) Hydro shocks</b>	1	TJ30BPH	Incl.	Incl.	



Skyjacker has the right combination in suspension, the lift, the look and the performance all at the right price. Not sure how extreme to go, limited budget no worries. Make your economical choice without sacrificing quality and upgrade later with Skyjacker long arm upgrades and control arm upgrades.

Jeep Wrangler TJ 1997-2006				
Kit Ref #	Description	Qty	Part #	Note
<b>4" Kit Standard Lower Arms 1997-02 Jeep Wrangler TJ - Suggested Tire Size - 33"</b>				
TJ401BPH	4" Jeep Wrangler with Standard Lower Arms, <b>includes (4) Hydro shocks</b>	1	TJ401BPH	
TJ401BPN	4" Jeep Wrangler with Standard Lower Arms, <b>includes (4) Nitro shocks</b>	1	TJ401BPN	
TJ401BPB	4" Jeep Wrangler with Standard Lower Arms, <b>includes (4) Black MAX shocks</b>	1	TJ401BPB	
TJ401BPM	4" Jeep Wrangler with Standard Lower Arms, <b>includes (4) M95 Monotube</b>	1	TJ401BPM	
<b>4" Kit Adjustable Flex Lower Arms 1997-02 Jeep Wrangler TJ - Suggested Tire Size - 33"</b>				
TJ401BPHX	4" Jeep Wrangler w/Adj Flex Lower Arms, <b>includes (4) Hydro shocks</b>	1	TJ401BPHX	
TJ401BPNX	4" Jeep Wrangler w/Adj Flex Lower Arms, <b>includes (4) Nitro shocks</b>	1	TJ401BPNX	
TJ401BPBX	4" Jeep Wrangler w/Adj Flex Lower Arms, <b>includes (4) Black MAX</b>	1	TJ401BPBX	
TJ401BPMX	4" Jeep Wrangler w/Adj Flex Lower Arms, <b>includes (4) M95 shocks</b>	1	TJ401BPMX	
<b>4" Kit Standard Lower Arms 2003-06 Jeep Wrangler TJ &amp; Wrangler Unlimited LJ - Suggested Tire Size - 33"</b>				
TJ403BPH	4" Jeep Wrangler with Standard Lower Arms, <b>includes (4) Hydro shocks</b>	1	TJ403BPH	
TJ403BPN	4" Jeep Wrangler with Standard Lower Arms, <b>includes (4) Nitro shocks</b>	1	TJ403BPN	
TJ403BPB	4" Jeep Wrangler with Standard Lower Arms, <b>includes (4) Black MAX shocks</b>	1	TJ403BPB	
TJ403BPM	4" Jeep Wrangler with Standard Lower Arms, <b>includes (4) M95 Monotube</b>	1	TJ403BPM	
<b>4" Kit Adjustable Flex Lower Arms 2003-06 Jeep Wrangler TJ &amp; Wrangler Unlimited LJ - Suggested Tire Size - 33"</b>				
TJ403BPHX	4" Jeep Wrangler w/Adj Flex Lower Arms, <b>includes (4) Hydro shocks</b>	1	TJ403BPHX	
TJ403BPNX	4" Jeep Wrangler w/Adj Flex Lower Arms, <b>includes (4) Nitro shocks</b>	1	TJ403BPNX	
TJ403BPBX	4" Jeep Wrangler w/Adj Flex Lower Arms, <b>includes (4) Black MAX shocks</b>	1	TJ403BPBX	
TJ403BPMX	4" Jeep Wrangler w/Adj Flex Lower Arms, <b>includes (4) M95 Monotube</b>	1	TJ403BPMX	
Additional Jeep applications available. See pages 158-175.				



TJ25BPH



Adjustable Flex Lower Arms



TJ401BPH

## Jeep Wrangler TJ 1997-2006 Rock Ready Long Arm Kits

Kit Ref #	Description	Qty	Part #	Front Shock	Rear Shock	Note	
<b>6" Rock Ready 1 Long Arm Lower Adjustable Control Arms - Suggested Tire Size - 36"</b>							
TJ60RR1K	6" Rock Ready 1 Long Arm Adjustable Lower Control Arms	1	TJ68RRX			10,11,12	
	6" Rock Ready 1 Long Arm Adjustable Lower Control Arms	1	TJ60RR1				
	6" Front Coils Pair	1	TJ60F				
	6" Rear Coils Pair	1	TJ60R				
	<b>Select a Shock Option F&amp;R Shocks (2) each of desired Shock Series</b>						
	<b>Hydro</b> Series Shock with Red Boot, <b>White</b>	2		H7049	H7063		
	<b>Nitro</b> Series Gas Shock with Red Boot, <b>White</b>	2		N8049	N8063		
	<b>Black MAX</b> Performance Shock with Black Boot, <b>Black</b>	2		B8549	B8563		
<b>M95</b> Monotube Performance Shock, <b>Silver</b>	2		M9549	M9563			
<b>6" Rock Ready 2 Long Arm Upper &amp; Lower Adjustable Control Arms - Suggested Tire Size - 36"</b>							
TJ60RR2K	6" Rock Ready 2 Long Arm Adjustable Upper & Lower Control Arms	1	TJ68RRX			10,11,12	
	6" Rock Ready 2 Long Arm Adjustable Upper & Lower Control Arms	1	TJ60X2				
	6" Front Coils Pair	1	TJ60F				
	6" Rear Coils Pair	1	TJ60R				
	<b>Select a Shock Option F&amp;R Shocks (2) each of desired Shock Series</b>						
	<b>Hydro</b> Series Shock with Red Boot, <b>White</b>	2		H7049	H7063		
	<b>Nitro</b> Series Gas Shock with Red Boot, <b>White</b>	2		N8049	N8063		
	<b>Black MAX</b> Performance Shock with Black Boot, <b>Black</b>	2		B8549	B8563		
<b>M95</b> Monotube Performance Shock, <b>Silver</b>	2		M9549	M9563			
<b>Notes</b>	<b>10)</b> Optional 1997-06 High Clearance Skid add SP176 *97-02 order SPS28M Mount. 03-06 Auto Only <b>11)</b> Non Rubicon Models Requires Slip Yoke Eliminator RR231 and CV Driveshaft TJRS <b>12)</b> Exhaust Modifications to Crossover Pipe required						

Additional Jeep applications available. See pages 158-175.





### Options Jeep Wrangler & Wrangler & Unlimited 2007-2016

Kit Ref #	Description	Qty	Part #	Note
<b>Wrangler TJ Options</b>	Heavy Duty DUAL LOAD Ball Joint Kit <b>(See page21)</b>	1	JD302B	<b>NEW!</b>
	OEM Steering Stabilizer Kit, <b>WHITE</b> w/Red Boot	1	7009	
	OEM Steering Stabilizer Kit, <b>Black MAX</b> w/Black Boot	1	8009	
	OEM Steering Stabilizer Kit, <b>SILVER</b> w/Black Boot	1	9009	
	Dual Steering Stabilizer Kit, <b>WHITE</b> w/Red Boot	1	7219	
	Dual Steering Stabilizer Kit, <b>Black MAX</b> w/Black Boot	1	8219	
	Dual Steering Stabilizer Kit, <b>SILVER</b> w/Black Boot	1	9219	
	Long Arm Upgrade 3.5-6" Lift Jeep Wrangler 1997-2006	1	TJ40RRX	11,12
	High Clearance Transfer Case Skid Plate (03-06 TJ Models)	1	SP176	10
	Upper Front & Rear Adjustable Control Arm Jeep Wrangler TJ LJ 1997-2006	1	JUL48SFX	
	Slip Yoke Eliminator	1	RR231	
	CV Driveshaft 2003-06 Auto & 6cyl with Dana 35 rear axle & OEM Skid	1	TJRS	
	CV Driveshaft 1997-03 5 Speed Manual & 6cyl Dana 35 rear axle & OEM Skid	1	TJRS	
	Front Upper Adjustable Control Arms	1	JULF24-FX	
	Rear Upper Adjustable Control Arms	1	JULR24-SX	
	Control Arm Cam Bolt Kit pair	1	CAM500	
	Extended Poly Bump stop Front or Rear 1997-06 Wrangler TJ LJ 2.5" pair	1	BP50	
	Bump stop extensions 2" Front or Rear coil pad mount 1997-06 Wrangler TJ LJ	1	BPS20	
	Bump stop extensions 3" Front or Rear coil pad mount 1997-06 Wrangler TJ LJ	1	BPS30	
	3/4" Coil Spring Isolator Pads, Pair 1997-06 Wrangler TJ LJ	1	SIP275	
	Rock Ready Steering Box Skid Plate 1997-06 Wrangler TJ LJ	1	RRSP20	
	NP231 Transfer Case Shifter Relocation Bracket 1997-06 Wrangler TJ LJ	1	JSRB231A	
	Front Stainless Steel DOT Brake Lines 4"-8" Lift/Pair 1997-06 Wrangler TJ LJ	1	FBL44	
	Rear Stainless Steel DOT Brake Line 4"-8" Lift/Single 1997-06 Wrangler TJ LJ	1	RBL98	
	High Capacity Trans Pan w/Drain Plug 1987-02 Wrangler with 999 Auto	1	OPA999	
	Heavy Duty Tie Rod Tube 1997-06 Wrangler TJ LJ	1	TR300	
Rear Shock Relocation Bracket Jeep Wrangler TJ Only 1997-2006	1	TJRSB10		
Rock Lock Front Selectable Front Sway Bar	1	JFSBA10		

#### Notes

- 10)** Optional 1997-06 High Clearance Skid add SP176 \*97-02 order SPS28M Mount. 03-06 Auto Only
- 11)** Non Rubicon Models Requires Slip Yoke Eliminator RR231 and CV Driveshaft TJRS
- 12)** Exhaust Modifications to Crossover Pipe required



FBL44



**NEW!**  
JD302B



RRSP20



OPA999



SP176



TJRS



RR231



JSRB231A



CAM500



# XJ



# Jeep



Shown in red for display only.



**NEW!**  
JD302B

**4.5", 6" and 8" Rock Ready® Cherokee XJ System SkyJacker® Suspensions** offers Jeep Cherokee XJ owners the ultimate in suspension technology. Whether you're twisting it up on the Red Rock of Moab or conquering the South American jungles of Peru, this is the suspension system you need.



Shown in red for display only.

## Jeep Cherokee XJ 1984-2001

Kit Ref #	Description	Qty	Part #	Front Shock	Rear Shock	Note
<b>2" Kit Poly Spacer Rear 1" Lift Shackles - Suggested Tire Size - 30"</b>						
XJ20	2" Poly Front with Rear 1" Lift Shackles	1	XJ20			
	<b>Select a Shock Option F&amp;R Shocks (2) each of desired Shock Series</b>					
	Hydro Series Shock with Red Boot, <b>White</b>	2		H7016	H7018	
	Nitro Series Gas Shock with Red Boot, <b>White</b>	2		N8016	N8018	
	Black MAX Performance Shock with Black Boot, <b>Black</b>	2		B8516	B8518	
M95 Monotube Performance Shock, <b>Silver</b>	2		M9516	M9518		
<b>3" Kit, Front Coils, Add-a-Leaf with Heavy Duty Control Arms - Suggested Tire Size - 31"</b>						
JC301K	3" Heavy Duty Lower Arms Component Box	1	JC30			16
	3" Front Coils Jeep	1	JC30F			
	Rear Add A Leafs, Pair	1	R3136			
	<b>Select a Shock Option F&amp;R Shocks (2) each of desired Shock Series</b>					
	Hydro Series Shock with Red Boot, <b>White</b>	2		H7016	H7018	
	Nitro Series Gas Shock with Red Boot, <b>White</b>	2		N8016	N8018	
	Black MAX Performance Shock with Black Boot, <b>Black</b>	2		B8516	B8518	
M95 Monotube Performance Shock, <b>Silver</b>	2		M9516	M9518		
<b>3" Kit, Sport Series Add-a-Leaf, No Control Arms with Hydro Shocks - Suggested Tire Size - 31"</b>						
JC31BKH	3" Coils, Rear Add-a-Leafs, No Arms, includes (4) Hydro shocks	1	JC301BH	Incl.	Incl.	15
<b>3" Kit, Front Coils, Rear Leaf Springs, No Control Arms with Hydro Shocks with Dana 35 Axle - Suggested Tire Size - 31"</b>						
JC315BKSH	3" Coils, Rear Leaf Springs, No Arms, (4) Hydro shocks, Dana 35 Axle	1	JC315BSH	Incl.	Incl.	15
	Rear Leaf Springs Cherokee	2	JC25RSB			
<b>3" Kit, Front Coils, Rear Leaf Springs, No Control Arms with Hydro Shocks with Chrysler 8.25 Axle - Suggested Tire Size - 31"</b>						
JC318BKSH	3" Coils, Rear Leaf Springs, No Arms, (4) Hydro shocks, 8.25 Axle	1	JC318BSH	Incl.	Incl.	15
	Rear Leaf Springs Cherokee	2	JC25RSB			
<b>4.5" Kit, Front Coils, w/Rear Add-a-Leaf/Shackle Standard Arms - Suggested Tire Size - 32"</b>						
JC451K	4.5" Front Coil Springs, Pair	1	JC45F			16
	4.5" Upper/Lower Flex Arms Component Box	1	JC45			
	Rear Add A Leafs, Pair	1	R3136			
	Hydro Series Shock with Red Boot, <b>White</b>	2		H7025	H7028	
	Nitro Series Gas Shock with Red Boot, <b>White</b>	2		N8025	N8028	
	Black MAX Performance Shock with Black Boot, <b>Black</b>	2		B8525	B8528	
M95 Monotube Performance Shock, <b>Silver</b>	2		M9525	M9528		
<b>4.5" Kit Front Coils, w/Rear Add-a-Leaf/Shackle Adjustable Flex Arms - Suggested Tire Size - 32"</b>						
JC451K-SVX	4.5" Front Coil Springs, Pair	1	JC45F			16
	4.5" Adjustable Upper & Lower Flex Arms Component Box	1	JC45-SVX			
	Rear Add A Leafs, Pair	1	R3136			
	<b>Select a Shock Option F&amp;R Shocks (2) each of desired Shock Series</b>					
	Hydro Series Shock w/Red Boot, <b>White</b>	2		H7025	H7028	
	Nitro Series Shock w/Red Boot, <b>White</b>	2		N8025	N8028	
	Black MAX Performance Shock with Black Boot, <b>Black</b>	2		B8525	B8528	
M95 Monotube Shock, <b>Silver</b>	2		M9525	M9528		
<b>Notes</b>	<b>16)</b> Transfer Case Lowering Kit Required <b>17)</b> Requires Slip Yoke Eliminator RR231 and CV Driveshaft					

JC31BKH



JC315BKSH



## Jeep Cherokee XJ 1984-2001

Kit Ref #	Description	Qty	Part #	Front Shock	Rear Shock	Note
<b>6" Long Arm w/Rear Leaf Springs w/Hydro Shocks &amp; Dana 35 Rear Axle - Suggested Tire Size - 33"</b>						
JC605BKSH	Front Coil Springs	1	JC60F	Incl.	Incl.	16,17
	Comp Box Cherokee Long Arm 6" w/Leafs	1	JC60RRX			
	Comp Box Cherokee Long Arm 6" w/Leafs, (4) Hydro shocks, Dana 35 Axle	1	JC605BSH			
	Rear Leaf Spring	2	JC55RSB			
<b>6" Long Arm w/Rear Leaf Springs w/Hydro Shocks &amp; Chrysler 8.25" Rear Axle - Suggested Tire Size - 33"</b>						
JC608BKSH	Front Coil Springs	1	JC60F	Incl.	Incl.	16,17
	Comp Box Cherokee Long Arm 6" w/Leafs	1	JC60RRX			
	Comp Box Cherokee Long Arm 6" w/Leafs, (4) Hydro shocks, 8.25 Axle	1	JC608BSH			
	Rear Leaf Spring	2	JC55RSB			
<b>Notes</b>	<b>15) OPTIONAL</b> Lower arms available TJLL24 <b>16) Transfer Lowering Required</b> <b>17) Requires Slip Yoke Eliminator RR231 &amp; CV Driveshaft</b>					
<b>Options Jeep Cherokee 1984-2001</b>						
Jeep Cherokee Options	Heavy Duty DUAL LOAD Ball Joint Kit <b>(See page 21)</b>	1	JD302B			<b>NEW!</b>
	<b>Transfer Case Lowering Kit</b> (Short Arm/OE Arm Kits)	1	TCL30			
	<b>Transfer Case Lowering Kit (Long Arm Kits)</b>	1	TCL32			
	<b>3/4" Coil Spring Isolator Pads, Pair</b>	1	SIP275			
	Lower Fixed Control Arms pair	1	TJLL24			
	OEM Steering Stabilizer Kit, WHITE w/Red Boot	1	7009			
	OEM Steering Stabilizer Kit, Black MAX w/Black Boot	1	8009			
	OEM Steering Stabilizer Kit, SILVER w/Black Boot	1	9009			
	Rear Shackles 1/2" Lift Jeep Cherokee 1988-2001	1	SH130			
	Heavy Duty Tie Rod Tube (1991 - 2001 Models)	1	TR300			
Slip Yoke Eliminator Kit (1984 - 2001 Models with NP231 Transfer Case)	1	RR231				

Additional Jeep applications available. See pages 158-175.



**6" 84-01 Cherokee Long-Arm Suspension**



# Jeep



**3" Jeep Cherokee Standard Kits & Systems Skyjacker® Suspensions** offers a 3" Kit with rear Add-A-Leafs, or a 3" System with Softride® rear springs. Both Kits feature Softride® front coil springs, track bar relocation bracket, greaseable lower control arms and 2-stage rear Softride® leaf springs.



JC451K-SVX



JC451K



TR300



**NEW!**  
JD302B



TCL30

# YJ

**2" and 4" Systems** These versatile Systems consist of front and rear Softride® multi-leaf springs and e-coated U-Bolts. The 4" features rear track bar brackets. The 2" and 4" systems are the perfect lifts for the less extreme off road driver. Complete your YJ today by ordering one of these versatile systems.



**2.5" and 4" Military Wrap** You will want to utilize the performance of the Double Military Wrap Leaf Springs to gain torque control, main leaf protection and exceptional ride quality. These durable, long lasting units have larger spring eyes at both ends. These larger eyes contain larger bushings designed for strength & longevity.





### Jeep Wrangler YJ 1987-1995

Kit Ref #	Description	Qty	Part #	Front Shock	Rear Shock	Note
<b>2.5" Kit Includes Hydro Shocks &amp; Sport Series Leaf Springs - Suggested Tire Size - 31"</b>						
YJ21BKH	Front Leaf Spring 2.5"	2	YJ20FSB			
	Rear Leaf Spring 2.5"	2	YJ20RSB			
	2.5" Component Box, includes (4) Hydro shocks	1	YJ21BH	Incl.	Incl.	
<b>4" Kit Includes Hydro Shocks &amp; Sport Series Leaf Springs - Suggested Tire Size - 33"</b>						
YJ41BKH	Front Leaf Spring 4"	2	YJ40FSB			18, 20
	Rear Leaf Spring 4"	2	YJ40RSB			
	4" Component Box, T-Case Lowering Kit, Front Sway Bar Extended Links, Front & Rear Track Bar Extension Brackets, includes (4) Hydro shocks	1	YJ41BH	Incl.	Incl.	
<b>2.5" Kit Softride® Series Leaf Springs - Suggested Tire Size - 31"</b>						
YJ20K	Front Leaf Spring 2.5"	2	YJ20FS			
	Rear Leaf Spring 2.5"	2	YJ20RS			
	2.5" Component Box	1	YJ20			
	<b>Select a Shock Option F&amp;R Shocks (2) each of desired Shock Series</b>					
	<b>Hydro Series Shock with Red Boot, White</b>	2		H7056	H7023	
	<b>Nitro Series Gas Shock with Red Boot, White</b>	2		N8056	N8023	
	<b>Black MAX Performance Shock with Black Boot, Black</b>	2		B8556	B8523	
	<b>M95 Monotube Performance Shock, Silver</b>	2		M9556	M9523	
<b>4" Kit Softride® Series Leaf Springs - Suggested Tire Size - 33"</b>						
YJ40K	Front Leaf Spring 4"	2	YJ40FS			18,19,20
	Rear Leaf Spring 4"	2	YJ40RS			
	4" Component Box	1	YJ40			
	<b>Select a Shock Option F&amp;R Shocks (2) each of desired Shock Series</b>					
	<b>Hydro Series Shock with Red Boot, white</b>	2		H7059	H7088	
	<b>Nitro Series Gas Shock with Red Boot, White</b>	2		N8059	N8088	
	<b>Black MAX Performance Shock with Black Boot, Black</b>	2		B8559	B8588	
	<b>M95 Monotube Performance Shock, Silver</b>	2		M9559	M9588	

Additional Jeep applications available. See pages 158-175.



YJ20K

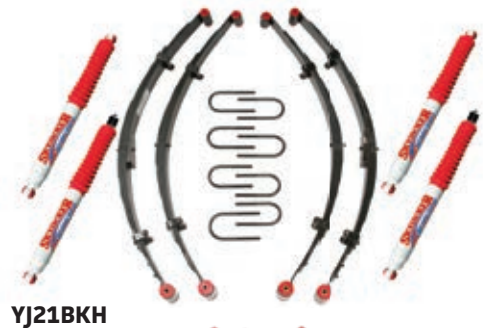

YJ21BKH



YJ60MK

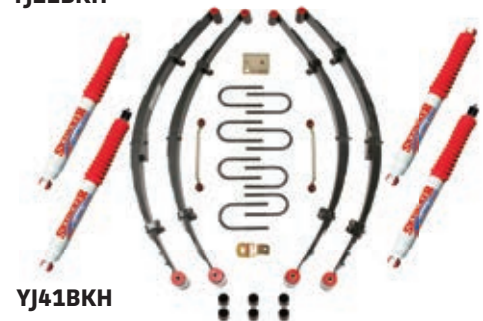

YJ41BKH



**Jeep Wrangler 1987-95 YJ 2.5" Rock Ready Military Wrap Series Leaf Springs - Suggested Tire Size - 31"**

YJ25K	Front Leaf Spring 2.5"	2	YJ25FS		
	Rear Leaf Spring 2.5"	2	YJ25RS		
	2.5" Component Box	1	YJ25		
	<b>Select a Shock Option F&amp;R Shocks (2) each of desired Shock Series</b>				
	<b>Hydro</b> Series Shock with Red Boot, <b>White</b>	2		H7056	H7023
	<b>Nitro</b> Series Gas Shock with Red Boot, <b>White</b>	2		N8056	N8023
	<b>Black MAX</b> Performance Shock, with Black Boot, <b>Black</b>	2		B8556	B8523
	<b>M95</b> Monotube Performance Shock, <b>Silver</b>	2		M9556	M9523



**YJ5LK**



### Jeep Wrangler YJ 1987-1995

Kit Ref #	Description	Qty	Part #	Front Shock	Rear Shock
<b>4" Kit Rock Ready Military Wrap Series Leaf Springs - Suggested Tire Size - 33"</b>					
<b>YJ45K</b>	Front Leaf Spring 4"	2	YJ45FS		
	Rear Leaf Spring 4"	2	YJ45RS		
	4" Component Box	1	YJ45		
	<b>Select a Shock Option F&amp;R Shocks (2) each of desired Shock Series</b>				
	<b>Hydro</b> Series Shock with Red Boot, <b>White</b>	2		H7059	H7088
	<b>Nitro</b> Series Gas Shock with Red Boot, <b>White</b>	2		N8059	N8088
	<b>Black MAX</b> Performance Shock, with Black Boot, <b>Black</b>	2		B8559	B8588
<b>M95</b> Monotube Performance Shock, <b>Silver</b>	2		M9559	M9588	
<b>6" Kit with Mono-linear Single Leaf Springs - Suggested Tire Size - 35"</b>					
<b>YJ60M</b>	6" Lift Mono-linear Complete Kit Box	1	YJ60M		
	<b>Select a Shock Option F&amp;R Shocks (2) each of desired Shock Series</b>				
	<b>Hydro</b> Series Shock with Red Boot, <b>White</b>	2		H7059	H7088
	<b>Nitro</b> Series Gas Shock with Red Boot, <b>White</b>	2		N8059	N8088
	<b>Black MAX</b> Performance Shock, with Black Boot, <b>Black</b>	2		B8559	B8588
<b>M95</b> Monotube Performance Shock, <b>Silver</b>	2		M9559	M9588	
<b>Notes</b>	<b>17)</b> Requires Slip Yoke Eliminator RR231 & CV Driveshaft <b>18)</b> YJ5LK 5th Link Traction Bar Recommended <b>19)</b> Transfer Case Lower Kit Required <b>20)</b> Drop Pitman Part #JA750 Required				
<b>Options Jeep Wrangler YJ 1987-95</b>					
<b>Jeep Wrangler YJ 1987-95 Options</b>	Heavy Duty DUAL LOAD Ball Joint Kit <b>(See page 21)</b>	1	JD302B		
	Drop Pitman Arm 4" lift Power Steering	1	JA750		
	OEM Steering Stabilizer <b>White</b> w/Red Boot	1	7009		
	OEM Steering Stabilizer <b>Black MAX</b> w/Black Boot	1	8009		
	OEM Steering Stabilizer Kit, <b>Silver</b> w/Black Boot	1	9009		
	Dual Steering Stabilizer Kit, <b>White</b> w/Red Boots	1	7200		
	Dual Steering Stabilizer <b>Black MAX</b> w/Black Boots	1	8200		
	Dual Steering Stabilizer <b>Silver</b> w/Black Boots	1	9200		
	Front & Rear Complete Frame Shackle Bushings Wrangler YJ 1987-95	1	SE3YJ		
	1" Lift Shackles Front Greasable Wrangler YJ 1987-95	1	SH2545F		
	1" Lift Shackles Rear Greasable Wrangler YJ 1987-95	1	SH2545R		
	High Capacity Transmission Pan w/Drain Plug 1987-95 Wrangler w/999 Auto	1	OPA999		
	Traction Bar 5th Link w/Cross member 1987-95 Wrangler	1	YJ5LK		
Traction Bar 5th Link w/o "NO" Cross member 1987-95 Wrangler	1	TB500K			

Additional Jeep applications available. See pages 158-175.



**NEW!**  
**JD302B**



**SH2545R**



**SH2545F**



# CJ

**2" & 4" Systems for the '55-'86 Jeep CJ**  
Many CJ owners will say the CJ is the only Jeep. Well Skyjacker® has designed the BEST rated springs for these true believers. These Softride® first-rate systems are the perfect way to transform your daily driver into the Conquering Jeep (CJ) you need it to be.





Jeep CJ5, CJ7, CJ8 1955-1986							
Kit Ref #	Description	Qty	Part #	Front Shock	Rear Shock	Note	
<b>2.5" 76-86 CJ w/Hydro Shocks &amp; Sport Series Leaf Springs - Suggested Tire Size - 31"</b>							
J21BKH	Front Leaf Spring 2.5"	2	J20FSB			20	
	Rear Leaf Spring 2.5"	2	J20RSB				
	2.5" Component Box, includes (4) Hydro shocks	1	J21BH	Incl.	Incl.		
<b>4" 76-86 CJ w/Hydro Shocks &amp; Sport Series Leaf Springs - Suggested Tire Size - 33"</b>							
J41BKH	Front Leaf Spring 4"	2	J40FSB			20	
	Rear Leaf Spring 4"	2	J40RSB				
	4" Component Box, includes (4) Hydro shocks	1	J41BH	Incl.	Incl.		
<b>2.5" 76-86 CJ Softride® Series Leaf Springs - Suggested Tire Size - 31"</b>							
J20K	Front Leaf Spring 2.5"	2	J20FS			20	
	Rear Leaf Spring 2.5"	2	J20RS				
	Component Box, 2.5"	1	J24				
	<b>Select a Shock Option F&amp;R Shocks (2) each of desired Shock Series</b>						
	<b>Hydro Series Shock with Red Boot, White</b>	2		H7012	H7023		
	<b>Nitro Series Gas Shock with Red Boot, White</b>	2		N8012	N8023		
	<b>Black MAX Performance Shock with Black Boot, Black</b>	2		B8512	B8523		
<b>M95 Monotube Performance Shock, Silver</b>	2		M9512	M9523			
<b>4" 76-86 CJ Softride® Series Leaf Springs - Suggested Tire Size - 33"</b>							
J40K	Front Leaf Spring 4"	2	J40FS			20	
	Rear Leaf Spring 4"	2	J40RS				
	Component Box, 4"	1	J24				
	<b>Select a Shock Option F&amp;R Shocks (2) each of desired Shock Series</b>						
	<b>Hydro Series Shock with Red Boot, White</b>	2		H7023	H7058		
	<b>Nitro Series Gas Shock with Red Boot, White</b>	2		N8023	N8058		
	<b>Black MAX Performance Shock with Black Boot, Black</b>	2		B8523	B8558		
<b>M95 Monotube Performance Shock, Silver</b>	2		M9523	M9558			
<b>2.5" 55-75 CJ Softride® Series Leaf Springs - Suggested Tire Size - 31"</b>							
J32K	Front Leaf Spring 2.5"	2	J32FS			20	
	Rear Leaf Spring 2.5"	2	J32RS				
	Component Box, 2.5"	1	J34				
	<b>Select Shock Option F&amp;R Shocks (2) each of desired Shock Series</b>						
	<b>Hydro Series Shock with Red Boot, White</b>	2		H7023	H7023		
	<b>Nitro Series Gas Shock with Red Boot, White</b>	2		N8023	N8023		
	<b>Black MAX Performance Shock with Black Boot, Black</b>	2		B8523	B8523		
<b>M95 Monotube Performance Shock, Silver</b>	2		M9523	M9523			
<b>Notes</b>	20) CJ8 Scrambler Models require rear fitted leaves, see page 231						

Additional Jeep applications available. See pages 158-175.

J41BKH



J34K



## Jeep CJ5, CJ7, CJ8 1955-1986

Kit Ref #	Description	Qty	Part #	Front Shock	Rear Shock	Note	
<b>4" 55-75 CJ Softride® Series Leaf Springs - Suggested Tire Size - 33"</b>							
<b>J34K</b>	Front Leaf Spring 4"	2	J34FS				
	Rear Leaf Spring 4"	2	J34RS				
	Component Box, 4"	1	J34				
	<b>Select Shock Option F&amp;R Shocks (2) each of desired Shock Series</b>						
	<b>Hydro</b> Series Shock with Red Boot, <b>White</b>	2		H7058	H7058		
	<b>Nitro</b> Series Gas Shock with Red Boot, <b>White</b>	2		N8058	N8058		
	<b>Black MAX</b> Performance Shock with Black Boot, <b>Black</b>	2		B8558	B8558		
<b>M95</b> Monotube Performance Shock, <b>Silver</b>	2		M9558	M9558			
<b>Notes</b>	<b>20)</b> CJ8 Scrambler Models require Rear fitted leaves, see page 231						

### Options Jeep Wrangler CJ 1955-86 / 93-98 Grand Cherokee ZJ

<b>Jeep Options</b>	Heavy Duty DUAL LOAD Ball Joint Kit 1993-98 Grand Cherokee ZJ ( <b>See page 21</b> )	1	JD302B			<b>NEW!</b>
	Drop Pitman Arm 4" lift <b>Power</b> Steering 1976-86	1	JA250			
	Drop Pitman Arm 4" lift <b>Manual</b> Steering 1976-86	1	JA150			
	Drop Pitman Arm 4" lift <b>Power</b> Steering 1972-75	1	JA550			
	Drop Pitman Arm 4" lift <b>Manual</b> Steering 1972-75	1	JA650			
	Drop Pitman Arm 2" lift <b>Power</b> Steering 1972-75	1	JA552			
	Drop Pitman Arm 2" lift <b>Manual</b> Steering 1972-75	1	JA652			
	OEM Steering Stabilizer Kit, <b>WHITE</b> w/Red Boot 1976-86 CJ	1	7001			
	Dual Steering Stabilizer Kit, <b>WHITE</b> w/Red Boots 1976-86 CJ	1	7200			
	OEM Steering Stabilizer Kit, <b>Black MAX</b> w/Black Boot 1976-86 CJ	1	8001			
	Dual Steering Stabilizer Kit, <b>Black MAX</b> w/Blacks Boot 1976-86 CJ	1	8200			
	OEM Steering Stabilizer Kit, <b>SILVER</b> w/Black Boot 1976-86 CJ	1	9001			
	Dual Steering Stabilizer Kit, <b>SILVER</b> w/Black Boots 1976-86 CJ	1	9200			
	OEM Steering Stabilizer, <b>WHITE</b> w/Red Boot 1993-98 Grand Cherokee ZJ	1	7009			
	OEM Steering Stabilizer, <b>Black MAX</b> w/Red Boot 1993-98 Grand Cherokee ZJ	1	8009			
	OEM Steering Stabilizer, <b>SILVER</b> w/Black Boot 1993-98 Grand Cherokee ZJ	1	9009			
	Front & Rear Complete Frame Shackle Bushings Wrangler CJ 1976-86	1	SE4CJ			
	Front & Rear Complete Frame Shackle Bushings CJ 1955-75	1	SE34J			

Additional Jeep applications available. See pages 158-175.



# Grand Cherokee

# Jeep



## Jeep Grand Cherokee 1993-2010 / Jeep Commander 2006-2010

Kit Ref #	Description	Qty	Part #	Front Shock	Rear Shock	Note
<b>2" Poly Spacer Kit - Jeep Grand Cherokee WK 2005-10, Jeep Commander 2006-10 - Suggested Tire Size - 30"- 30.5"</b>						
WK20	2" Poly Spacer Kit Front & Rear	1	WK20			
	<b>Select Shock Option F&amp;R Shocks (2) each of desired Series</b>					
	Hydro Series Shock with Red Boot, <b>White</b>	2			H7088	
	Nitro Series Gas Shock with Red Boot, <b>White</b>	2			N8088	
	Black MAX Performance Shock with Black Boot, <b>Black</b>	2			B8588	
M95 Monotube Performance Shock, <b>Silver</b>	2			M9558		
<b>2" Poly Spacer Kit - Jeep Grand Cherokee WJ 1999-2004 - Suggested Tire Size - 31"</b>						
WJ20	2" Poly Spacer Kit Front & Rear	1	WJ20			
	<b>Select Shock Option F&amp;R Shocks (2) each of desired Shock Series</b>					
	Hydro Series Shock with Red Boot, <b>White</b>	2		H7016	H7044	
	Nitro Series Gas Shock with Red Boot, <b>White</b>	2		N8016	N8044	
	Black MAX Performance Shock with Black Boot, <b>Black</b>	2		B8516	B8544	
M95 Monotube Performance Shock, <b>Silver</b>	2		M9516	M9544		
<b>2" Poly Spacer Kit - Jeep Grand Cherokee ZJ 1993-98 - Suggested Tire Size - 31"</b>						
ZJ20	2" Poly Spacer Kit Front & Rear	1	ZJ20			
	<b>Select Shock Option F&amp;R Shocks (2) each of desired Shock Series</b>					
	Hydro Series Shock with Red Boot, <b>White</b>	2		H7016	H7023	
	Nitro Series Gas Shock with Red Boot, <b>White</b>	2		N8016	N8023	
	Black MAX Performance Shock with Black Boot, <b>Black</b>	2		B8516	B8523	
M95 Monotube Performance Shock, <b>Silver</b>	2		M9516	M9523		
<b>3" Kit - Jeep Grand Cherokee ZJ 1993-98 - Suggested Tire Size - 31"</b>						
GC301K	Front Coil Springs Pair	1	JC30F			
	Rear Coil Springs Pair	1	GC20R			
	Component Box 3"	1	GC30			
	<b>Select Shock Option F&amp;R Shocks (2) each of desired Shock Series</b>					
	Hydro Series Shock with Red Boot, <b>White</b>	2		H7016	H7023	
	Nitro Series Gas Shock with Red Boot, <b>White</b>	2		N8016	N8023	
	Black MAX Performance Shock with Black Boot, <b>Black</b>	2		B8516	B8523	
M95 Monotube Performance Shock, <b>Silver</b>	2		M9516	M9523		



ZJ20



GC301K



WJ20

# Liberty



## Jeep Liberty KK & KJ 2002-2012

Kit Ref #	Description	Qty	Part #	Front Shock	Rear Shock	Note
<b>2.5-3" Jeep Liberty KK 2008-12 - Suggested Tire Size - 31"</b>						
LIB258K	Component Box, 2.5-3" Front	1	LIB250			
	2-2.5" Rear Coils Springs Pair	1	LIB208R			
	<b>Select Shock Option F&amp;R Shocks (2) each of desired Shock Series</b>					
	<b>Hydro Series Shock with Red Boot, White</b>	2			H7088	
	<b>Nitro Series Gas Shock with Red Boot, White</b>	2			N8088	
	<b>Black MAX Performance Shock with Black Boot, Black</b>	2			B8588	
<b>M95 Monotube Performance Shock, Silver</b>	2			M9558		
<b>2.5-3" Jeep Liberty KJ 2002-07 - Suggested Tire Size - 31"</b>						
LIB250K	Component Box, 2.5-3" Front	1	LIB250			
	2-2.5" Rear Coils Springs Pair	1	LIB25R			
	<b>Select Shock Option F&amp;R Shocks (2) each of desired Shock Series</b>					
	<b>Hydro Series Shock with Red Boot, White</b>	2			H7088	
	<b>Nitro Series Gas Shock with Red Boot, White</b>	2			N8088	
	<b>Black MAX Performance Shock with Black Boot, Black</b>	2			B8588	
<b>M95 Monotube Performance Shock, Silver</b>	2			M9558		
<b>2" Poly Spacer Kit, Jeep Liberty KK 2008-12 - Suggested Tire Size - 30"-30.5"</b>						
KKN25	2" Poly Spacer Kit, Front & Rear	1	KKN25			
	<b>Select Shock Option F&amp;R Shocks (2) each of desired Shock Series</b>					
	<b>Hydro Series Shock with Red Boot, White</b>	2			H7088	
	<b>Nitro Series Gas Shock with Red Boot, White</b>	2			N8088	
	<b>Black MAX Performance Shock with Black Boot, Black</b>	2			B8588	
	<b>M95 Monotube Performance Shock, Silver</b>	2			M9558	
<b>2" Poly Spacer Kit, Jeep Liberty KJ 2002-07 - Suggested Tire Size - 30"-30.5"</b>						
KJ25	2" Poly Spacer Kit, Front & Rear	1	KJ25			
	<b>Select Shock Option F&amp;R Shocks (2) each of desired Shock Series</b>					
	<b>Hydro Series Shock with Red Boot, White</b>	2			H7088	
	<b>Nitro Series Gas Shock with Red Boot, White</b>	2			N8088	
	<b>Black MAX Performance Shock with Black Boot, Black</b>	2			B8588	
	<b>M95 Monotube Performance Shock, Silver</b>	2			M9558	

Additional Jeep applications available. See pages 158-175.



KJ25

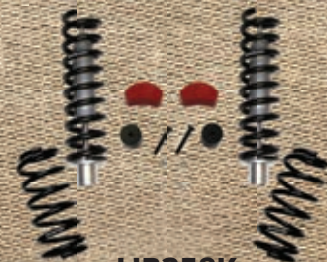

LIB258K

# Wagoneer

# Jeep



JP40K



JP40KS

Kit Ref #	Description	Qty	Part #	Front Shock	Rear Shock	Note
<b>4" Jeep Cherokee, Wagoneer, Full Size 1984-1991 Front Leaf Springs, Rear Blocks - Suggested Tire Size - 35"</b>						
JP45K	Front Leaf Springs, 4"	2	JP40FS			
	Component Kit Box, 4"	1	JP45			
	Jeep Full Size Pitman Arm Required	1	JA350			23
	<b>Select Shock Option F&amp;R Shocks (2) each of desired Shock Series</b>					
	<b>Hydro</b> Series Shock with Red Boot, <b>White</b>	2		H7088	H7088	
	<b>Nitro</b> Series Gas Shock with Red Boot, <b>White</b>	2		N8088	N8088	
	<b>Black MAX</b> Performance Shock with Black Boot, <b>Black</b>	2		B8588	B8588	
<b>M95</b> Monotube Performance Shock, <b>Silver</b>	2		M9558	M9558		
<b>4" Jeep Cherokee, Wagoneer, Full Size 1984-1991 Front Leaf Springs &amp; Rear Leaf Springs - Suggested Tire Size - 35"</b>						
JP45KS	Front Leaf Springs, 4"	2	JP40FS			
	Rear Leaf Springs, 4"	2	JP40RS			
	System Box, 4"	1	JP45S			
	Jeep Full Size Pitman Arm Required	1	JA350			23
	<b>Select Shock Option F&amp;R Shocks (2) each of desired Shock Series</b>					
	<b>Hydro</b> Series Shock with Red Boot, <b>White</b>	2		H7088	H7088	
	<b>Nitro</b> Series Gas Shock with Red Boot, <b>White</b>	2		N8088	N8088	
<b>Black MAX</b> Performance Shock with Black Boot, <b>Black</b>	2		B8588	B8588		
<b>M95</b> Monotube Performance Shock, <b>Silver</b>	2		M9558	M9558		
<b>4" Jeep J10/J20 Full Size 1974-83 Front Leaf Springs, Rear Blocks - Suggested Tire Size - 35"</b>						
JP40K	Front Leaf Springs, 4"	2	JP40FS			
	Component Kit Box, 4"	1	JP40			
	Jeep Full Size Pitman Arm Required	1	JA350			23
	<b>Select Shock Option F&amp;R Shocks (2) each of desired Shock Series</b>					
	<b>Hydro</b> Series Shock with Red Boot, <b>White</b>	2		H7088	H7088	
	<b>Nitro</b> Series Gas Shock with Red Boot, <b>White</b>	2		N8088	N8088	
	<b>Black MAX</b> Performance Shock with Black Boot, <b>Black</b>	2		B8588	B8588	
<b>M95</b> Monotube Performance Shock, <b>Silver</b>	2		M9558	M9558		
<b>4" Jeep J10/J20 Full Size 1974-83 Front Leaf Springs &amp; Rear Leaf Springs - Suggested Tire Size - 35"</b>						
JP40KS	Front Leaf Springs, 4"	2	JP40FS			
	Rear Leaf Springs, 4"	2	JP40RS			24
	System Box, 4"	1	JP40S			
	Jeep Full Size Pitman Arm Required	1	JA350			23
	<b>Select Shock Option F&amp;R Shocks (2) each of desired Shock Series</b>					
	<b>Hydro</b> Series Shock with Red Boot, <b>White</b>	2		H7088	H7088	
	<b>Nitro</b> Series Gas Shock with Red Boot, <b>White</b>	2		N8088	N8088	
<b>Black MAX</b> Performance Shock with Black Boot, <b>Black</b>	2		B8588	B8588		
<b>M95</b> Monotube Performance Shock, <b>Silver</b>	2		M9558	M9558		
<b>Notes</b>	<b>23)</b> Power Steering Models Only <b>24)</b> 74-75 Models MUST have 131" Wheel Base & 7,200 lb. GVWR or More for Rear Springs to fit.					



# 1500



**New Bolt in Skyjacker LeDuc Series coilovers are tuned and tested by Curt LeDuc with application specific valving for maximum performance on and off-road. Purchase as kit or coilover box upgrade for your current Skyjacker Suspension.**



C14662LSKM

C14662ALSKM

## Chevrolet/GMC 1500 Pickup 2014-2018

Kit Ref #	Description	Qty	Part #	Front Shock	Rear Shock	Note
<b>Chevrolet/GMC 4WD - 2014 - 18, 6" LeDuc Series Coilover with Rear Blocks &amp; M95 Shocks (Models with ALUMINUM Knuckles or STAMPED STEEL A-ARMS)</b>						
<b>C14662ALSKM</b> <b>New</b>	Coilover Box Coilover Component box/Upgrade box	1	C7146LS			2, 3, 23, 32, 33
	Comp Box LeDuc Series Coilover 6"-7"ALUMINUM Knuckle	1	C14661AAL			
	Comp Box 6" with M95 Monotube Shocks	1	C14661PRM		Incl.	
<b>Chevrolet/GMC 4WD 1500 - 2014 - 16, 6" LeDuc Series Coilover Lift with Rear Blocks &amp; M95 Shocks (Models with OE STEEL Knuckles Only)</b>						
<b>C14662LSKM</b> <b>New</b>	Coilover Component box/Upgrade box	1	C7146LS			1, 3, 23, 32, 33
	Comp Box Strut Spacer 6"-7" STEEL Knuckle	1	C14661A			
	Comp Box 6" with M95 Monotube Shocks	1	C14661PRM		Incl.	
<b>Notes</b>	<b>1)</b> Works "Only" with vehicles equipped with OE STEEL Steering Knuckles <b>2)</b> Works "Only" with vehicles equipped with OE ALUMINUM Steering Knuckles <b>3)</b> OEM Wheels work with exception of 18" Wheels, OEM 18" Wheels require wheel spacers part # WSP655 <b>10)</b> Models with factory 18"/20" wheels must run 18"/20" wheels when changing to aftermarket wheels. <b>23)</b> Rear Replacement Leaf options available, see GM Master Pages 76-97 <b>32)</b> See Wheel & Tire fitment requirements page 238-239 <b>33)</b> If driver line vibration occurs order front drive shaft part #GM10146DS					
NOTE: Many additional applications and Steering Stabilizers available. See GM Chevrolet Master Pages 76						

## Chevrolet/GMC 1500 Pickup 2014-2018

Kit Ref #	Description	Qty	Part #	Front Shock	Rear Shock	Note	
<b>Chevrolet/GMC 1500 4WD - 2007-18 - 2" Leveling Kits</b>							
<b>C1420LMSA</b>	2" Leveling Kit, Mounts Below Struts	1	C1420LMSA				
<b>C720MS</b>	2" Leveling Kit, Mounts Above Struts	1	C720MS				
<b>Chevrolet/GMC 1500 4WD - Models Built May 2016 - 2018 - (Equipped with STAMPED STEEL A-ARMS Only) - Models Built 2014 - April 2016 - ( Equipped with ALUMINUM KNUCKLES Only)</b>							
<b>4" Front Strut Spacer Lift with Rear Blocks</b>							
<b>C14460APK</b>	Comp Box, Stamped Steel A-Arms or Aluminum Knuckles 4"	1	C14461AAL			23, 32	
	Comp Box Strut Spacers 4"	1	C14460SP				
	Comp Box 4" Rear	1	C7361PR				
	<b>Select Required Shock Option (2) each of desired Series</b>						
		<b>Hydro Series Shock with Red Boot, White</b>	2			H7017	
		<b>Nitro Series Gas Shock with Red Boot, White</b>	2			N8017	
		<b>Black MAX Performance Shock with Black Boot, Black</b>	2			B8517	
	<b>M95 Monotube Performance Shock, Silver</b>	2			M9517		

**Chevrolet/GMC 1500 4WD - Models Built May 2016 - 2018 - (Equipped with STAMPED STEEL A-ARMS Only)**  
**- Models Built 2014 - April 2016 - ( Equipped with ALUMINUM KNUCKLES Only)**

**6-7" Front Strut Spacer Lift with Rear Blocks**

<b>C14660APK</b>	Comp Box, Stamped Steel A-Arms or Aluminum Knuckles 6"	1	C14661AAL			23, 32, 34	
	Comp Box Strut Spacer 6-7"	1	C14660SP				
	Comp Box 6" Rear	1	C14661PR				
	<b>Select Required Shock Option (2) each of desired Series</b>						
	<b>Hydro Series Shock with Red Boot, White</b>	2			H7036		
	<b>Nitro Series Gas Shock with Red Boot, White</b>	2			N8036		
	<b>Black MAX Performance Shock with Black Boot, Black</b>	2			B8536		
<b>M95 Monotube Performance Shock, Silver</b>	2			M9536			

**Chevrolet/GMC 1500 4WD - Models Built May 2016 - 2018 - (Equipped with STAMPED STEEL A-ARMS Only)**  
**- Models Built 2014 - April 2016 - ( Equipped with ALUMINUM KNUCKLES Only)**

**6-7" Front Strut Spacer System with Rear Leaf Springs**

<b>C14660APKS</b>	Comp Box, Stamped Steel A-Arms or Aluminum Knuckles 6"	1	C14661AAL			23, 32, 34	
	Comp Box Strut Spacers 6-7"	1	C14660SP				
	System Box 6" Rear	1	C14661PRS				
	Rear Leaf Springs	2	CR55S				
	<b>Select Required Shock Option (2) each of desired Series</b>						
	<b>Hydro Series Shock with Red Boot, White</b>	2			H7036		
	<b>Nitro Series Gas Shock with Red Boot, White</b>	2			N8036		
<b>Black MAX Performance Shock with Black Boot, Black</b>	2			B8536			
<b>M95 Monotube Performance Shock, Silver</b>	2			M9536			

**Chevrolet/GMC 1500 4WD - 2014 - April 2016 - 4" Front Strut Spacer Lift with Rear Blocks (models equipped with OE CAST STEEL Knuckles Only)**

<b>C14460PK</b>	Comp Box CAST STEEL Knuckles 4"	1	C14461A			1, 23, 32	
	Comp Box Strut Spacers 4"	1	C14460SP				
	Comp Box 4" Rear	1	C7361PR				
	<b>Select Required Shock Option (2) each of desired Series</b>						
	<b>Hydro Series Shock with Red Boot, White</b>	2			H7017		
	<b>Nitro Series Gas Shock with Red Boot, White</b>	2			N8017		
	<b>Black MAX Performance Shock with Black Boot, Black</b>	2			B8517		
<b>M95 Monotube Performance Shock, Silver</b>	2			M9517			

**Chevrolet/GMC 1500 4WD - 2014 - April 2016 - 6-7" Front Strut Spacer Lift with Rear Blocks (models equipped with OE CAST STEEL Knuckles Only)**

<b>C14660PK</b>	Comp Box CAST STEEL Knuckles 6"	1	C14661A			1, 3, 23, 32, 33, 34	
	Comp Box Strut Spacers 6-7"	1	C14660SP				
	Comp Box 6" Rear	1	C14661PR				
	<b>Select Required Shock Option (2) each of desired Series</b>						
	<b>Hydro Series Shock with Red Boot, White</b>	2			H7036		
	<b>Nitro Series Gas Shock with Red Boot, White</b>	2			N8036		
	<b>Black MAX Performance Shock with Black Boot, Black</b>	2			B8536		
<b>M95 Monotube Performance Shock, White</b>	2			M9536			

**Chevrolet/GMC 1500 4WD - 2014 - April 2016 - 6-7" Front Strut Spacer System with Rear Springs (models equipped with OE CAST STEEL Knuckles Only)**

<b>C14660PKS</b>	Comp Box CAST STEEL Knuckles 6"	1	C14661A			1, 3, 23, 32, 33, 34	
	Comp Box Strut Spacers 6-7"	1	C14660SP				
	System Box 6" Rear	1	C14661PRS				
	Rear Leaf Springs	2	CR55S				
	<b>Select Required Shock Option (2) each of desired Series</b>						
	<b>Hydro Series Shock with Red Boot, White</b>	2			H7036		
	<b>Nitro Series Gas Shock with Red Boot, White</b>	2			N8036		
<b>Black MAX Performance Shock with Black Boot, Black</b>	2			B8536			
<b>M95 Monotube Performance Shock, White</b>	2			M9536			
<b>Options</b>	Coilover 07-18 GM 1500 Coilover Component box/Upgrade box	1	C7146LS			14	

**Notes**  
**1)** Works "Only" on vehicles equipped with OE STEEL Steering Knuckles **2)** Works "Only" on vehicles equipped with OE ALUMINUM Steering Knuckles **3)** OEM Wheels work with exception of 18", OEM 18" Wheels require wheel spacers # WSP655  
**10)** Models with factory 18"/20" wheels must run 18"/20" wheels when changing to aftermarket wheels.  
**14)** Coilover upgrade for installed 6" kits **23)** Rear Replacement Leaf options available, see GM Master Pages 76-97  
**32)** Wheel/Tire fitment requirements page 238-239 **33)** If driver line vibration occurs order front drive shaft part #GM10146DS



# GM 1500



GM may have redesigned the newer 1500 but Skyjacker® has released two new suspension lift kits that redefine this all new setup. The 4 & 6" kits include CNC Machined Steering knuckles, front & rear crossmembers, 1-piece differential skid plate, 4-link relocation brackets and replacement variable rate Softride® rear coil springs.



Skyjacker's 6" suspension lift system for the '07-'18 GM K1500 is the ultimate in performance, comfort, and stability for these popular vehicles. Skyjacker's adjustable Performance Struts provide the best ride possible and achieve a full 6" of lift in the front. This complete system features heavy-duty front and rear crossmembers along with the necessary differential drop brackets. Replacement CNC machined ductile iron steering knuckles are Incl. and maintain the correct steering geometry, so there is no need for modifications to the factory steering assembly.





# 1500



## Chevrolet/GMC 1500 Pickup 2007-2013

Kit Ref #	Description	Qty	Part #	Front Shock	Rear Shock	Note	
<b>Chevrolet/GMC 4WD 1500 - 2007-18 - 2" Leveling</b>							
<b>C1420LMSA</b>	2" Leveling Kit Below Strut Mount	1	C1420LMSA			32	
<b>C720MS</b>	2" Leveling Kit Above Strut Spacer	1	C720MS			32	
<b>Chevrolet/GMC 4WD 1500 - 2007-13 - 4" Front Strut Spacer Lift with Rear Blocks</b>							
<b>C7360PK</b>	Comp Box Main 4"	1	C7361A			10, 23, 32	
	Comp Box Strut Spacer 4"	1	C7360SP				
	Comp Box 4" Rear	1	C7361PR				
	<b>Select Required Shock Option (2) each of desired Series</b>						
		<b>Hydro Series Shock with Red Boot, White</b>	2			H7017	
		<b>Nitro Series Gas Shock with Red Boot, White</b>	2			N8017	
		<b>Black MAX Performance Shock with Black Boot, Black</b>	2			B8517	
	<b>M95 Monotube Performance Shock, Silver</b>	2			M9517		
<b>Chevrolet/GMC 4WD 1500 - 2007-13 - 6" Front Strut Spacer Lift with Rear Blocks</b>							
<b>C7660PK</b>	Comp Box Main 6"	1	C7661A			10, 23, 32, 33	
	Comp Box Strut Spacer 6"	1	C7660SP				
	Comp Box 6" Rear	1	C7661PR				
	<b>Select Required Shock Option (2) each of desired Series</b>						
		<b>Hydro Series Shock with Red Boot, White</b>	2			H7036	
		<b>Nitro Series Gas Shock with Red Boot, White</b>	2			N8036	
		<b>Black MAX Performance Shock with Black Boot, Black</b>	2			B8536	
	<b>M95 Monotube Performance Shock, Silver</b>	2			M9536		
<b>Chevrolet/GMC Colorado/Canyon - 2004-2018</b>							
<b>Colorado/Canyon 4WD/2WD- 2015-18 - 1" or 2" Leveling Kit</b>							
<b>CC12MS</b>	Colorado Canyon Leveling Kit	1	CC12MS			<b>NEW!</b>	
<b>Colorado/Canyon 4WD/2WD- 2004-12 - 2" Leveling Kit (fits models equipped with OE Torsion bars only)</b>							
<b>C104KE</b>	Colorado Canyon Leveling Kit Torsion Keys	1	C104KE			11, 13, 32	
<b>Colorado/Canyon 4WD - 2004-12 - 4" Lift with Rear Add-a-Leaf (fits models equipped with OE Torsion bars only)</b>							
<b>CC409K</b>	Component Box 4WD 4"	1	CC409			11, 13, 23, 32, 33	
	Add-a-Leaf Rear	1	RCC25				
	<b>Select Required Shock Option F&amp;R Shocks (2) each of desired Series</b>						
		<b>Hydro Series Shock with Red Boot, White</b>	2		H7040	H7084	
		<b>Nitro Series Gas Shock with Red Boot, White</b>	2		N8040	N8084	
	<b>Black MAX Performance Shock with Black Boot, Black</b>	2		B8540	B8584		
<b>Chevrolet/GMC 4WD 1500 - 2007-12 - Chevrolet/GMC 4WD Colorado/Canyon</b>							
<b>Notes</b>	<b>10)</b> OEM Wheels can be used. <b>11)</b> Can "NOT" reuse OE Wheels, requires 4.75" Back Spacing, see wheel and tire fitments in rear of catalog <b>12)</b> Fits vehicles equipped with OE Torsion Bar front suspensions <b>13)</b> Fits 4WD ONLY, See Master catalog pages for 2WD applications <b>23)</b> Rear Replacement Leaf options available, see GM Master Pages 76-97 <b>32)</b> See Wheel & Tire fitment requirements page 238-239 <b>33)</b> Rear leaf springs available - Order (2) CCR25S instead of RCC25						

NOTE: Many additional applications and Steering Stabilizers available. See GM Chevrolet Master Pages 76-97



CC12MS



CC409K



C1420LMSA



# 2500HD 3500HD

## Chevrolet/GMC 2500HD/3500HD 4WD Pickup 2011-2018

Kit Ref #	Description	Qty	Part #	Front Shock	Rear Shock	Note
<b>Chevrolet/GMC 4WD 2500-3500HD - 2011-18 - 2" Leveling</b>						
<b>C115KE</b>	2" Torsion Keys 2500HD (Shock Extensions Incl.)	1	C115KE			7, 32
<b>Option</b>	2" Block and U-Bolt Kit	1	BUK2789			
<b>Chevrolet/GMC 4WD 2500HD - 2011-18 - 6" - Lift Rear Blocks with Torsion Bar Lowered</b>						
<b>C11680K</b>	Main Component Box, 6"	1	C1168A			4, 5, 8, 9, 23, 32
	Component Box 2500HD, 6-7"	1	C1178B			
	Front & Rear Shock Box	1	C1178N		Incl.	
<b>Chevrolet/GMC 4WD 2500HD - 2011-18 - 7" Lift - Rear Blocks with Torsion Bar raised</b>						
<b>C11781K</b>	Main Component Box, 7"	1	C1178A			4, 6, 8, 9, 23, 32
	Component Box 2500HD, 6-7"	1	C1178B			
	Raised Torsion Bar Box	1	C1178TR			
	Front & Rear Shock Box	1	C1178N		Incl.	
<b>Chevrolet/GMC 4WD 3500HD - 2011-18 - 6" Lift - Rear Blocks with Torsion Bar Lowered</b>						
<b>C11680KH</b>	Main Component Box, 6"	1	C1168A			4, 5, 8, 9, 23
	Component Box 3500HD, 6-7"	1	C1178BH			
	Front & Rear Shock Box	1	C1178N		Incl.	
<b>Chevrolet/GMC 4WD 3500HD - 2011-18 with Torsion Bar Raised</b>						
<b>C11781KH</b>	Main Component Box, 7"	1	C1178A			4, 6, 8, 9, 23, 32
	Component Box 3500HD, 6-7"	1	C1178BH			
	Raised Torsion Bar Box	1	C1178TR			
	Front & Rear Shock Box	1	C1178N		Incl.	
<b>Chevrolet/GMC 4WD 2500-3500HD</b>						
<b>Options</b>	DEF UREA Skid Plate 2011-16 GM 2500/3500HD	1	DEFG114SP			



Skyjacker® DEF front Urea Tank Skid Plate • DEFG114SP





Chevrolet/GMC 2500HD/3500HD 4WD Pickup 2001-2010						
<b>Chevrolet/GMC 4WD/2WD 2500-3500HD - 2001-10 Torsion Bar 2" Leveling</b>						
<b>C103KE</b>	2" KEYS 2500HD/3500HD (Shock Extensions Incl.)	1	C103KE			7, 16, 32
<b>Chevrolet/GMC 4WD 2500-3500HD - 2001-10 - 3" Torsion Bar Suspension Kit with Rear Lift Blocks</b>						
<b>C9381K</b>	Component Box Kit, 3"	1	C9381			
	Rear Block & U-Bolt Kit	1	BUK2082F			
	<b>Select Required Shock Option F&amp;R Shocks (2) each of desired Series</b>					
	<b>Hydro Series Shock with Red Boot, White</b>	2		H7074	H7017	
	<b>Nitro Series Gas Shock with Red Boot, White</b>	2		N8074	N8017	
	<b>Black MAX Performance Shock with Black Boot, Black</b>	2		B8574	B8517	
	<b>M95 Monotube Performance Shock, Silver</b>	2		M9574	M9517	
<b>Chevrolet/GMC 4WD 2500-3500HD - 2001-10 - 6" Torsion Bar Suspension Kit with Rear Lift Blocks</b>						
<b>C9681K-NSP</b>	Main Component Box Kit, 6"	1	C9681A-NSP			9, 18, 23, 32
	Component Box Kit, 6"	1	C9682B			
	<b>Select Required Shock Option F&amp;R Shocks (2) each of desired Series</b>					
	<b>Hydro Series Shock with Red Boot, White</b>	2		H7074	H7036	
	<b>Nitro Series Gas Shock with Red Boot, White</b>	2		N8074	N8036	
	<b>Black MAX Performance Shock with Black Boot, Black</b>	2		B8574	B8536	
	<b>M95 Monotube Performance Shock, Silver</b>	2		M9574	M9536	
<b>Notes</b>	<p>4) OEM 17" &amp; 18" Wheels can be 5) This choice uses a lowering bracket for Torsion bar 6) This choice raises the torsion bars for additional clearance 7) Shock extensions Incl. in this kit 8) In event of rear driveline vibration install Carrier Bearing kit part# CBL2500 9) OEM Wheels can be used See tire/Wheel fitment guide rear of catalog 16) Works with OE color codes Orange, Green, White, Brown 17) Works with OE color codes Purple, Blue, Yellow 18) 3500 Models will require U-bolts and Modification to knuckle 23) Rear Replacement Leaf options available, see GM Master Pages 76-97 32) See Wheel &amp; Tire fitment requirements page 238-239</p>					

NOTE: Many additional applications and Steering Stabilizers available. See GM Chevrolet Master Pages 76-97



C9681K-NSP



6" C11680K



7" C11781K

# RAM



# 1500

**Dodge may have redesigned the 09 and newer 1500 Ram,** but Skyjacker® has released two new suspension lift kits that redefine this all new setup. The 4 & 6" kits include CNC Machined Steering knuckles, front & rear crossmembers, 1-piece differential skid plate, 4-link relocation brackets and replacement variable rate Softride® rear coil springs.



**Skyjacker's 1.5-2.5" Inch Quick-Leveling** One of the latest introductions to the Skyjacker® Leveling Kit line is the leveling strut for the 06-16 Dodge Ram 1500 Pickup. This new addition to the S8000 Performance Strut Series is engineered beyond OE and delivers 1.5-2.5" Inches of front lift for a more level stance. These twin tube, nitrogen gas charged units are designed with a 1.375" piston size (larger than OE) with true velocity sensitive valving. These performance strut designs deliver a noticeable advantage in strength, durability, and performance. The factory coils are retained for a cost effective option that gives you improved stability, better handling, and great looks.



**D6912ST**





Dodge Ram 1500 Pickup 2012-2018						
Kit Ref #	Description	Qty	Part #	Front Shock	Rear Shock	Note
<b>Dodge Ram 4WD 1500 - 2006-17 - 2" Strut Top Mount Spacer Leveling Kit</b>						
<b>R620MS</b>	2006-17 2" Strut Spacer Leveling Kit	1	R620MS			33
<b>Dodge Ram 4WD 1500 - 2006-17 - 1.5 - 2.5" Adjustable Strut Leveling Kit</b>						
<b>D6912ST</b>	2006-17 1.5 - 2.5" Adjustable Strut Leveling Kit	1	D6912ST			33
<b>Dodge Ram 4WD 1500 &amp; Eco Diesel - 2012-18 - 4" Front Strut Spacer Lift with Replacement Rear Coil Springs</b>						
<b>D1440SSK</b>	Component Box A, 4"	1	D1440A			32
	Component Box B, 4"	1	D1440B			
	Component Box C, 4"	1	D1440C			
	<b>Select Required Shock Option (2) each of desired Series</b>					
	<b>Hydro</b> Series Shock with Red Boot, White	2			H7017	
	<b>Nitro</b> Series Gas Shock with Red Boot, White	2			N8017	
<b>Black MAX</b> Performance Shock with Black Boot, Black	2			B8517		
<b>M95</b> Monotube Performance Shock, Silver	2			M9517		
<b>Dodge Ram 4WD 1500 &amp; Eco Diesel 1500 - 2012-18 - 6" Front Strut Spacer Lift with Replacement Rear Coil Springs</b>						
<b>D1460SSK</b>	Component Box A, 6"	1	D1460A			10, 32
	Component Box B, 6"	1	D1460B			
	Component Box C, 6"	1	D1460C			
	<b>Select Required Shock Option (2) each of desired Series</b>					
	<b>Hydro</b> Series Shock with Red Boot, White	2			H7070	
	<b>Nitro</b> Series Gas Shock with Red Boot, White	2			N8070	
<b>Black MAX</b> Performance Shock with Black Boot, Black	2			B8570		
<b>M95</b> Monotube Performance Shock, Silver	2			M9570		
<b>Notes</b>	<b>10)</b> TRX Models Require Part # D960TRX4 <b>32)</b> See Wheel & Tire fitment requirements page 238-239 <b>33)</b> Will <b>NOT</b> fit TRX Models or Air Ride					
<b>NOTE: Many additional model applications and steering stabilizers available. See Dodge &amp; Ram Master Pages 98-115.</b>						



R620MS



D1460SSK



Brake Lines

# RAM



# 1500

**2", 3" and 5" Dodge Kits & Systems** To match its "big rig" styling Skyjacker® has created the most versatile line of Kits and Systems for the '94-'01 Dodge trucks. 3" options include Kit or System and Class I or Class II options. 5" include such choices as Standard or Single Flex links, Kit or System and Class I or Class II options.



**6" System For The Dodge Ram 1500** Dodge may have 're-designed' the Ram, but Skyjacker® has unleashed a Refined Revolution of Suspension Technology that reaches new heights of performance and durability. To measure up to the tough, work hard, play harder capability, this dynamic suspension system is ready for a hearty dose of your favorite off-road pastime.



## Dodge Ram 1500 Pickup 2006-2018

Kit Ref #	Description	Qty	Part #	Front Shock	Rear Shock	Note	
<b>Dodge Ram 4WD 1500 - 2006-18 - 2" Strut Top Mount Spacer Leveling Kit</b>							
<b>D620MS</b>	2" Top Mount Strut Spacer Leveling Kit	1	D620MS			33	
<b>Dodge Ram 4WD 1500 - 2006-18 - 1.5 - 2.5" Adjustable Replacement Strut Leveling Kit</b>							
<b>D6912ST</b>	1.5 - 2" Adjustable Strut Leveling Kit	1	D6912ST			33	
<b>Dodge Ram 4WD 1500 - 2009-11 - 4" Front Strut Spacer Lift with Replacement Rear Coil Springs</b>							
<b>D940SSK</b>	Component Box 4"	1	D1440A			32	
	Component Box 4"	1	D946B				
	Component Box 4"	1	D1440C				
	<b>Select Required Shock Option (2) each of desired Series</b>						
		<b>Hydro Series Shock with Red Boot, White</b>	2			H7017	
		<b>Nitro Series Gas Shock with Red Boot, White</b>	2			N8017	
		<b>Black MAX Performance Shock with Black Boot, Black</b>	2			B8517	
	<b>M95 Monotube Performance Shock, Silver</b>	2			M9517		
<b>Dodge Ram 1500 - 2009-11 - 6" Front Strut Spacer Lift with Replacement Rear Coil Springs</b>							
<b>D960SSK</b>	Component Box 6"	1	D1460A			32	
	Component Box 6"	1	D946B				
	Component Box 6"	1	D1460C				
	<b>Select Required Shock Option (2) each of desired Series</b>						
		<b>Hydro Series Shock with Red Boot, White</b>	2			H7070	
		<b>Nitro Series Gas Shock with Red Boot, White</b>	2			N8070	
		<b>Black MAX Performance Shock with Black Boot, Black</b>	2			B8570	
	<b>M95 Monotube Performance Shock, Silver</b>	2			M9570		
<b>Dodge Ram 4WD 1500 - 2006-08 - 4" Front Strut Spacer Lift with Rear Lift Blocks</b>							
<b>D640SSK</b>	Component Box 4"	1	D646A			32	
	Component Box 4"	1	D646B				
	Component Box 4"	1	D640C				
	<b>Select Required Shock Option (2) each of desired Series</b>						
		<b>Hydro Series Shock with Red Boot, White</b>	2			H7070	
		<b>Nitro Series Gas Shock with Red Boot, White</b>	2			N8070	
		<b>Black MAX Performance Shock with Black Boot, Black</b>	2			B8570	
	<b>M95 Monotube Performance Shock, Silver</b>	2			M9570		
<b>Dodge Ram 4WD 1500 - 2006-08 - 6" Front Strut Spacer Lift with Rear Lift Blocks</b>							
<b>D660SSK</b>	Component Box 6"	1	D646A			32	
	Component Box 6"	1	D646B				
	Component Box 6"	1	D660C				
	<b>Select Required Shock Option (2) each of desired Series</b>						
		<b>Hydro Series Shock with Red Boot, White</b>	2			H7070	
		<b>Nitro Series Gas Shock with Red Boot, White</b>	2			N8070	
		<b>Black MAX Performance Shock with Black Boot, Black</b>	2			B8570	
	<b>M95 Monotube Performance Shock, Silver</b>	2			M9570		
<b>Notes</b>	32) See Wheel & Tire fitment requirements page 238-239 33) Will not fit TRX Models or Air Ride						

NOTE: Many additional applications and steering stabilizers available. See Dodge & Ram Master Pages 98-115.



**D960SSK**



**D6912ST**



**D640SSK**



# RAM



# 2500

**Skyjacker® is leading the trail** in the RAM Market with the 5" suspension lift for the "big and bold" '10-12 RAM 2500 and 3500 4WD includes replacement full-height Softride® front coil springs, greaseable upper and lower control arms, relocation brackets for the upper arms, pitman arm, bump stops and all necessary hardware.

**Skyjacker® Lives Up To Its Reputation** in the Dodge Market The 5" suspension lift for the "big and bold" '03-'09 Dodge 2500 and 3500 4WD includes replacement full-height Softride® front coil springs, greaseable upper and lower control arms, relocation brackets for the upper arms, pitman arm, bump stops and all necessary hardware.



## Ram 2500 4WD Pickup 2014-2018

Kit Ref #	Description	Qty	Part #	Front Shock	Rear Shock	Note
<b>Ram Gas &amp; Diesel 2500 - 3500 4WD - 2014-18 - 2" Leveling with Shock Extensions Incl.</b>						
<b>R1325MSB</b>	2" Metal Spacer Leveling Kit w/ Shock Extension Brackets	1	R1325MSB			32
<b>Ram Gas &amp; Diesel 2500 -3500 4WD - 2014-18 - 2" Leveling with "No" Shock Extensions Incl. (requires front shock choice)</b>						
<b>R1325MS</b>	2" Metal Spacer Leveling Kit (No Shock Ext)	1	R1325MS			32
<b>Ram Diesel 2500 -3500 4WD - 2014-18 - 2.5" Leveling Front Coil Springs</b>						
<b>R25</b>	2.5" Front Coil Springs	1	R25			32
	<b>Select Required Front Shock option, Rear Shocks Optional (2) each of desired Series</b>					
	<b>Hydro Series Shock with Red Boot, White</b>	2		H7091	H7092	
	<b>Nitro Series Gas Shock with Red Boot, White</b>	2		N8091	N8092	
	<b>Black MAX Performance Shock with Black Boot, Black</b>	2		B8591	B8592	
<b>M95 Monotube Performance Shock, Silver</b>	2		M9591	M9592		
<b>Ram Diesel 2500 4WD - 2014-18 - 4" Lift with Front and Rear Coil Springs (equipped with OE Rear Coils Only)</b>						
<b>R14451K</b>	Ram Front Coil Springs / Pair 4"	1	R45			32
	Component Box 4-6"	1	R461			
	Component Box Ram 4" w/Rear Coil Springs	1	R144C			
	<b>Select Required Shock Option F&amp;R Shocks (2) each of desired Series</b>					
	<b>Hydro Series Shock with Red Boot, White</b>	2		H7092	H7093	
	<b>Nitro Series Gas Shock with Red Boot, White</b>	2		N8092	N8093	
	<b>Black MAX Performance Shock with Black Boot, Black</b>	2		B8592	B8593	
	<b>M95 Monotube Performance Shock, Silver</b>	2		M9592	M95932	
<b>Ram Diesel 2500 4WD - 2014-18 - 6" Lift with Replacement Front and Rear Coil Springs (equipped with OE Rear Coils Only)</b>						
<b>R14651K</b>	Ram Front Coil Springs/pair 6"	1	R65			32
	Component Box 4-6"	1	R461			
	Component Box Ram 6" w/Rear Coil Springs	1	R146C			
	<b>Select Required Shock Option F&amp;R Shocks (2) each of desired Series</b>					
	<b>Hydro Series Shock with Red Boot, White</b>	2		H7093	H7094	
	<b>Nitro Series Gas Shock with Red Boot, White</b>	2		N8093	N8094	
	<b>Black MAX Performance Shock with Black Boot, Black</b>	2		B8593	B8594	
	<b>M95 Monotube Performance Shock, Silver</b>	2		M9593	M95942	
<b>Ram 2500 4WD - 2014-18</b>						
<b>Options</b>	HD OEM Steering Stabilizer <b>White</b> w/Red Boot	1	7014			
	HD OEM Steering Stabilizer <b>Black MAX</b> w/Black Boot	1	8014			
	HD OEM Steering Stabilizer <b>Silver</b> w/Black Boot	1	9014			
	DUAL Steering Stabilizer <b>White</b> w/Black Boot	1	7214			
	DUAL Steering Stabilizer <b>Black MAX</b> w/Black Boot	1	8214			
	DUAL Steering Stabilizer <b>Silver</b> w/Black Boot	1	9214			
<b>Notes</b>	32) See Wheel & Tire fitment requirements page 238-239					
NOTE: Many additional applications and steering stabilizers available. See Dodge & Ram Master Pages 98-115.						



**R1325MSB**



**R14451k**

# 2500-3500



10-13 Ram 2500 / 10-12 Ram 3500 Pickup						
Kit Ref #	Description	Qty	Part #	Front Shock	Rear Shock	Note
<b>Ram 4WD 10-13 2500 / 10-12 3500 &amp; Mega Cab - 2.5" Leveling</b>						
<b>D27MK</b>	2.5" Metal Spacer Leveling Kit	1	D25MS			32
	Rear Add-a-Leaf	1	R332			
	<b>Select Required Shock Option F&amp;R Shocks (2) each of desired Series</b>					
	<b>Hydro Series Shock with Red Boot, White</b>	2		H7092	H7036	
	<b>Nitro Series Gas Shock with Red Boot, White</b>	2		N8092	N8036	
	<b>Black MAX Performance Shock, Black</b>	2		B8592	B8536	
<b>M95 Monotube Performance Shock, Silver</b>	2		M9592	M9536		
<b>Ram 4WD 10-13 2500 / 10-12 3500 &amp; Mega Cab - 3.5-4" Lift with Rear Add-a-Leaf</b>						
<b>D2513K</b>	Diesel Front Coil Springs, Pair	1	D25			23, 32
	Component Box w/Rear Add-a-leaf	1	D2513			
	<b>Select Required Shock Option F&amp;R Shocks (2) each of desired Series</b>					
	<b>Hydro Series Shock with Red Boot, White</b>	2		H7092	H7036	
	<b>Nitro Series Gas Shock with Red Boot, White</b>	2		N8092	N8036	
	<b>Black MAX Performance Shock with Black Boot, Black</b>	2		B8592	B8536	
<b>M95 Monotube Performance Shock, Silver</b>	2		M9592	M9536		
<b>Ram 4WD 10-13 2500 / 10-12 3500 &amp; Mega Cab - 6" Lift with Rear Add-a-Leaf</b>						
<b>D4510K</b>	Diesel Front Coil Springs, Pair	1	D45			23, 32
	Main Component Box	1	D45510			
	Component Box w/ Rear Add-a-Leafs	1	D4513			
	<b>Select Required Shock Option F&amp;R Shocks (2) each of desired Series</b>					
	<b>Hydro Series Shock with Red Boot, White</b>	2		H7094	H7036	
	<b>Nitro Series Gas Shock with Red Boot, White</b>	2		N8094	N8036	
	<b>Black MAX Performance Shock with Black Boot, Black</b>	2		B8594	B8536	
<b>M95 Monotube Performance Shock, Silver</b>	2		M9594	M9536		
<b>Ram 4WD 10-13 2500 / 10-12 3500 &amp; Mega Cab</b>						
<b>Options</b>	HD OEM Steering Stabilizer <b>White</b> w/Red Boot	1	7013			
	HD OEM Steering Stabilizer <b>Black MAX</b> w/Black Boot	1	8013			
	HD OEM Steering Stabilizer <b>Silver</b> w/Black Boot	1	9013			
	DUAL Steering Stabilizer <b>White</b> w/Red Boot	1	7239			
	DUAL Steering Stabilizer <b>Black MAX</b> w/Black Boot	1	8239			
	DUAL Steering Stabilizer <b>Silver</b> w/Black Boot	1	9239			
<b>Notes</b>	<b>23)</b> Rear Replacement Leaf options available, see Dodge Ram Master Pages 98-115 <b>32)</b> See Wheel & Tire fitment requirements page 238-239					

NOTE: Many additional applications and steering stabilizers available. See Dodge & Ram Master Pages 98-115.



D25MS



D2513k



Steering Stabilizer



# RAM



## Ram 3500 Pickup 2013-2018

Kit Ref #	Description	Qty	Part #	Front Shock	Rear Shock	Note
<b>Ram Gas &amp; Diesel 3500 4WD - 2014-18 - 2" Leveling with Shock Extensions Incl.</b>						
<b>R1325MSB</b>	2" Metal Spacer Leveling Kit w/ Shock Extension Brackets	1	R1325MSB			32
<b>Ram Gas &amp; Diesel 3500 4WD - 2014-18 - 2" Leveling with "No" Shock Extensions Incl. (requires front shock choice)</b>						
<b>R1325MS</b>	2" Metal Spacer Leveling Kit (No Shock Ext)	1	R1325MS			32
<b>Ram Diesel 3500 4WD - 2014-18 2" - 2.5" Leveling Front Coil Springs</b>						
<b>R25</b>	2.5" Front Coil Springs	1	R25			32
	<b>Select Required Front Shock option, Rear Shocks Optional (2) each of desired Series</b>					
	<b>Hydro Series Shock with Red Boot, White</b>	2		H7091	H7092	
	<b>Nitro Series Gas Shock with Red Boot, White</b>	2		N8091	N8092	
	<b>Black MAX Performance Shock with Black Boot, Black</b>	2		B8591	B8592	
<b>M95 Monotube Performance Shock, Silver</b>	2		M9591	M9592		
<b>Ram Diesel 4WD 3500 - 2013-18 - 3.5-4" Lift with Rear Lift Blocks (equipped with OE Rear Leaf Springs Only)</b>						
<b>R13451K</b>	Diesel Front Coil Springs, Pair 4"	1	R45			32
	Component Box 4-6"	1	R461			
	Component Box w/Rear Blocks	1	R134			
	<b>Select Required Shock Option F&amp;R Shocks (2) each of desired Series</b>					
	<b>Hydro Series Shock with Red Boot, White</b>	2		H7092	H7090	
	<b>Nitro Series Gas Shock with Red Boot, White</b>	2		N8092	N8090	
	<b>Black MAX Performance Shock with Black Boot, Black</b>	2		B8592	B8590	
<b>M95 Monotube Performance Shock, Silver</b>	2		M9592	M9590		
<b>Ram Diesel 4WD 3500 - 2013-18 - 5.5-6" Lift with Rear Lift Blocks (equipped with OE Rear Leaf Springs Only)</b>						
<b>R13651K</b>	Front Coil Springs Pair 6"	1	R65			32
	Component Box 4-6"	1	R461			
	Component Box w/Rear Blocks	1	R136			
	<b>Select Required Shock Option F&amp;R Shocks (2) each of desired Series</b>					
	<b>Hydro Series Shock with Red Boot, White</b>	2		H7093	H7090	
	<b>Nitro Series Gas Shock with Red Boot, White</b>	2		N8093	N8090	
	<b>Black MAX Performance Shock with Black Boot, Black</b>	2		B8593	B8590	
<b>M95 Monotube Performance Shock, Silver</b>	2		M9593	M9590		
<b>Ram Diesel 4WD 3500 - 2013-18</b>						
<b>Options</b>	HD OEM Steering Stabilizer <b>White</b> w/Red Boot	1	7014			
	HD OEM Steering Stabilizer <b>Black MAX</b> w/Black Boot	1	8014			
	HD OEM Steering Stabilizer <b>Silver</b> w/Black Boot	1	9014			
	DUAL Steering Stabilizer <b>White</b> w/Red Boot	1	7214			
	DUAL Steering Stabilizer <b>Black MAX</b> w/Black Boot	1	8214			
	DUAL Steering Stabilizer <b>Silver</b> w/Black Boot	1	9214			
<b>Notes</b>	<b>32) See Wheel &amp; Tire fitment requirements page 238-239</b>					

NOTE: Many additional applications and steering stabilizers available. See Dodge & Ram Master Pages 98-115.



R1325MSB



R13451k



R25

# F-150



*New Bolt in Skyjacker LeDuc Series coilovers are tuned and tested by Curt LeDuc with application specific valving for maximum performance on and off-road. Purchase as kit or coilover box upgrade for your current Skyjacker Suspension.*



F1562LSKM



## Ford F150 4WD Pickup 2009-2018

Kit Ref #	Description	Qty	Part #	Front Shock	Rear Shock	Note
<b>Ford F150 4WD 2009-18 - 2" Leveling Kit</b>						
<b>F920MS</b>	2" Leveling Kit	1	F920MS			32
<b>Options</b>	2" Rear Block and U-Bolt kit	1	BUK2074DF			
	<b>Optional Rear Shocks (2) each of desired Series, See master catalog page 188</b>					
<b>Ford F150 4WD 2015-18 - 4.5" Lift Front Strut Spacer Lift with Rear Lift Blocks with Hydro Shocks</b>						
<b>F1545BKH</b>	Main Box 4.5"-6"	1	F15461A			32
	Component Box 4.5" w/Hydro Shocks	1	F1545BH*		Incl.	
<b>Shock Options</b>	<b>*Additional Shock Options Available by replacing above Component Shock Box (1) of desired Series</b>					
	Component Box 4.5" w/Nitro Shocks	1	F1545BN		Incl.	32
	Component Box 4.5" w/Black MAX Shocks	1	F1545BB		Incl.	32
	Component Box 4.5" w/M95 Monotube Shocks	1	F1545BM		Incl.	32
<b>Ford F150 4WD 2015-18 - 6" Lift Front Strut Spacer Lift with Rear Lift Blocks with Hydro Shocks</b>						
<b>F1560BKH</b>	Main Box 4.5"-6"	1	F15461A			32
	Component Box 6" w/Hydro Shocks	1	F1560BH*			32
<b>Shock Options</b>	<b>*Additional Shock Options Available by replacing above Component Shock Box (1) of desired Series</b>					
	Component Box 6" w/Nitro Shocks	1	F1560BN		Incl.	32
	Component Box 6" w/Black MAX Shocks	1	F1560BB		Incl.	32
	Component Box 6" w/M95 Monotube Shocks	1	F1560BM		Incl.	32
<b>Ford F150 4WD 2015-18 - 6" LeDuc Series Fox Coilover Front Lift with Rear Lift Blocks and M95 Series Performance Monotube Rear Shock</b>						
<b>F1562LSKM New</b>	LeDuc Series Coilovers 6"	1	F1562LS			32
	Component Box 4.5"-6"	1	F15461A			32
	Component Box 6" w/M95 Monotube Shocks	1	F1562BM			32
<b>Ford F150 4WD 2009-14 - 4.5" Lift with Rear Lift Blocks with Hydro Shocks</b>						
<b>F945BKH</b>	Main Box 4.5"-6"	1	F9461A			32
	Component Box 4.5" w/Hydro Shock	1	F945BH		Incl.	
<b>Ford F150 4WD 2009-14 - 6" Lift with Rear Lift Blocks with Hydro Shocks</b>						
<b>F960BKH</b>	Main Box 4.5"-6"	1	F9461A			32
	Component Box 6" w/Hydro Shock	1	F960BH		Incl.	
<b>Ford F150 4WD 2009-13 - 6" LeDuc Serie Fox Coilover Front Lift with Rear Lift Blocks and M95 Series Performance Monotube Rear Shock</b>						
<b>F962LSKM New</b>	LeDuc Series Coilover 6"	1	F962LS			32
	Main Box 4.5"-6"	1	F9461A			
	Component Box 6" w/M95 Monotube Shocks	1	F962BM		Incl.	
<b>Notes</b>	<b>32) See Wheel &amp; Tire fitment requirements page 238-239</b>					

NOTE: Many additional applications and steering stabilizers available. See Ford Master Pages 116-155.



**F920MS**



**F1560BKH**



# F-150

**3" Kit with Rear Blocks & Ubolts** This 3" suspension kit replaces the factory struts with a performance strut & retains the factory coil springs. You keep the same quiet comfortable ride, but gain the extra clearance needed for a more aggressive tire.



**66-79 F150 Various Kits & Systems Ranging in Heights From 2" - 9" of Lift** Skyjacker® offers a full line of straight axle Ford Kits and Systems that can take your classic Ford to new heights. A wide range of lifts from 2" - 9" gives you the choice of lift desired.



**80-96 F150/Bronco Class I System** The Class I System features replacement cast steel radius arm brackets which are exclusive to Skyjacker®. This System also features Race Style heavy-duty replacement center hinge brackets. The coil springs in these Systems are preset and formed from 5160H chromium alloy to ensure a higher tensile strength and longer life along with the added benefit of full-height rear springs.

## Ford F150 Pickup 2004-2008

Kit Ref #	Description	Qty	Part #	Front Shock	Rear Shock	Note
<b>Ford F150 2004-08 - 2.5" Metal Leveling Kit</b>						
FF25MS	2.5" Leveling Kit	1	FF25MS			32
<b>Shock Options</b>	<b>Optional Rear Shocks select (2) each of desired Series, See master catalog page 194-196</b>					
<b>4WD Only - Ford F150 - 2004-08 - 3" Lift Performance Front Struts with Rear Blocks &amp; Ubolts - Shocks Incl.</b>						
F430STBH	3" Kit, 4WD w/Hydro Shocks	1	F430STBH		Incl.	32
F430STBN	3" Kit, 4WD w/Nitro Shocks	1	F430STBN		Incl.	32
F430STBB	3" Kit, 4WD w/Black MAX Shocks	1	F430STBB		Incl.	32
F430STBM	3" Kit, 4WD w/M95 Monotube Shocks	1	F430STBM		Incl.	32
<b>4WD Only - Ford F150 2004-08 - 6" Lift with Front Strut Spacers with Rear Blocks &amp; Ubolts - Shocks Incl.</b>						
F460BKH	Main Box 6"	1	F4461A			32
	Component Box 6" w/Hydro Shocks	1	F460BH		Incl.	
F460BKN	Main Box 6"	1	F4461A			32
	Component Box 6" w/Nitro Shocks	1	F460BN		Incl.	
F460BKB	Main Box 6"	1	F4461A			32
	Component Box 6" w/Black MAX Shocks	1	F460BB		Incl.	
F460BKM	Main Box 6"	1	F4461A			32
	Component Box 6" w/M95 Monotube Shocks	1	F460BM		Incl.	
<b>4WD Only - Ford F150 2004-08 - 6" Lift with Performance Front Struts</b>						
F4601K-NSP	Main Box 6"	1	F4601A-NSP			32
	Component Box 6" with Performance Front Struts	1	F4602BST			
	<b>Select Required Shock Option F&amp;R Shocks (2) each of desired Series</b>					
		Hydro Series Shock with Red Boot, White	2			H7060
		Nitro Series Gas Shock with Red Boot, White	2			N8060
		Black MAX Performance Shock with Black Boot, Black	2			B8560
	M95 Monotube Performance Shock, Silver	2			M9560	
<b>2WD Only - Ford F150 - 2004-08 - 3" Lift Performance Front Struts with Rear Blocks &amp; Ubolts - Shocks Incl.</b>						
F432STBH	3" Kit, 2WD w/Hydro Shocks	1	F432STBH		Incl.	32
F432STBN	3" Kit, 2WD w/Nitro Shocks	1	F432STBN		Incl.	32
F432STBB	3" Kit, 2WD w/Black MAX Shocks	1	F432STBB		Incl.	32
F432STBM	3" Kit, 2WD w/M95 Monotube Shocks	1	F432STBM		Incl.	32
<b>Ford F150 Pickup 1997-2003</b>						
<b>4WD Only - Ford F150 1997-03 - 2" Torsion Bar Kit</b>						
F301KE	2" Torsion Key Leveling Kit	1	F301KE			
<b>4WD Only - Ford F150 1997-03 - 6" Lift with Rear Blocks &amp; UBolts</b>						
F9701K-NSP	Main Box 6"	1	F9701A-NSP			23,26,32
	Component Box 6"	1	F9701B			
	<b>Select Required Shock Option F&amp;R Shocks (2) each of desired Series</b>					
		Hydro Series Shock with Red Boot, White	2		H7097	H7061
		Nitro Series Gas Shock with Red Boot, White	2		N8097	N8061
		Black MAX Performance Shock with Black Boot, Black	2		B8597	B8561
	M95 Monotube Performance Shock, Silver	2		M9597	M9561	
<b>Notes</b>	<b>23) Rear Replacement Leaf options available, see Ford Master Pages 116-155 26) Regular Cab &amp; Short Bed models are equipped with factory tapered blocks. To correct driveline angle Part # RBF20 is required 32) See Wheel &amp; Tire fitment requirements page 238-239.</b>					



F460BKH



F430STBH / F432STBH



FF25MS



# F250/350 SUPER DUTY

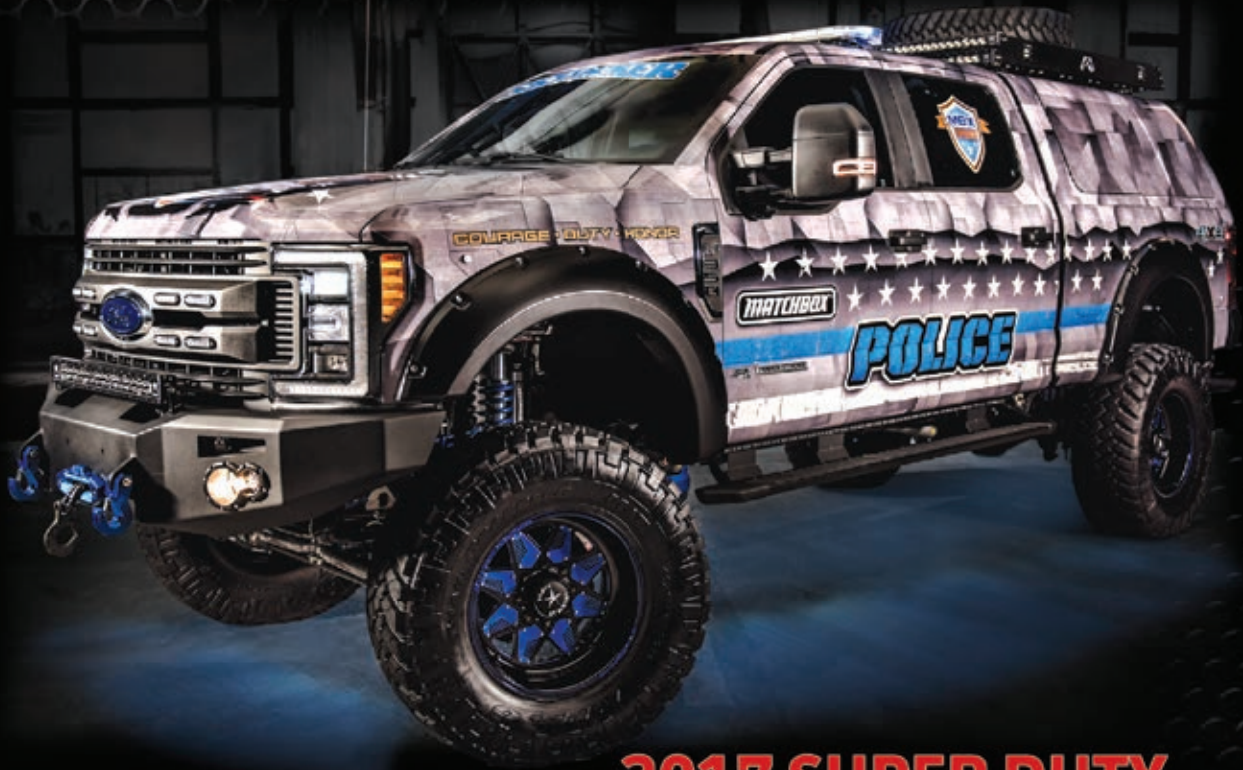

## 2017 SUPER DUTY

- New Variable Rate Coils for Improved Ride Quality
  - Radius Arm Brackets to Correct Geometry
    - Drop Pitman Arm Included ( 6"-8.5" )
      - HD Track Bar Relocation Bracket
  - Available with Fully Adjustable 4-Links
  - 3", 5" & 7" Rear Leaf Springs Available





## Ford F250/350 Super Duty Pickup 2017-18

Kit Ref #	Description	Qty	Part #	Front Shock	Rear Shock	Note
<b>Ford Gas &amp; Diesel F250/350 - 2.5" Metal Spacer Kit with Front Track Bar Bracket</b>						
<b>F528MSP</b>	2.5" Metal Spacer Leveling Kit w/ Front Track Bar Bracket	1	F528MSP			22
<b>Ford Gas &amp; Diesel F250/350 - 1" Metal Spacer Front Kit</b>						
<b>F51MS</b>	1" Metal Spacer Front Lift	1	F51MS			22
<b>Ford Gas &amp; Diesel F250/350 - 2.5" Metal Spacer Front Leveling Kit</b>						
<b>F52MS</b>	2.5" Metal Spacer Front Leveling Kit	1	F52MS			22, 24
	<b>Select Required Shock Option F&amp;R Shocks (2) each of desired Series</b>					
	<b>Hydro Series Shock with Red Boot, White</b>	2		H7091	H7038	
	<b>Nitro Series Gas Shock with Red Boot, White</b>	2		N8091	N8038	
	<b>Black MAX Performance Shock with Black Boot, Black</b>	2		B8591	B8538	
<b>M95 Monotube Performance Shock, Silver</b>	2		M9591	M9538		
<b>Ford Diesel F250/350 - 2 - 2.5" Front Coil Springs / Variable Rate</b>						
<b>F525V</b>	2" - 2.5" Front Coils / Variable Rate	1	F525V			22, 24
	<b>Select Required Shock Option F&amp;R Shocks (2) each of desired Series</b>					
	<b>Hydro Series Shock with Red Boot, White</b>	2		H7091	H7038	
	<b>Nitro Series Gas Shock with Red Boot, White</b>	2		N8091	N8038	
	<b>Black MAX Performance Shock with Black Boot, Black</b>	2		B8591	B8538	
<b>M95 Monotube Performance Shock, Silver</b>	2		M9591	M9538		
<b>Ford Gas &amp; Diesel F250/350 - 4" Metal Spacer Kit with Black MAX shocks</b>						
<b>F1740SPB</b>	4" Complete Front & Rear Kit with Front & Rear <b>Black MAX</b> shocks	1		Incl.	Incl.	21



## 2017-18 Ford F250 Super Duty Pickup

Kit Ref #	Description	Qty	Part #	Front Shock	Rear Shock	Note
<b>Ford Diesel F250 - 2017-18 - 4" Lift Coil Springs / Variable Rate</b>						
<b>F17451K</b>	4 " Front Coils / Variable Rate	1	F545V			
	Component Box F250 4"	1	F17451			21
<b>F17451KS</b>	4 " Front Coils / Variable Rate	1	F545V			
	System Box F250 4"	1	F17451S			21
	Rear Leaf Springs, 3"	2	FR173S			<b>NEW!</b>
	<b>Select Required Shock Option F&amp;R Shocks (2) each of desired Series</b>					
	<b>Hydro</b> Series Shock with Red Boot, <b>White</b>	2		H7092	H7068	
	<b>Nitro</b> Series Gas Shock with Red Boot, <b>White</b>	2		N8092	N8068	
	<b>Black MAX</b> Performance Shock with Black Boot, <b>Black</b>	2		B8592	B8568	
	<b>M95</b> Monotube Performance Shock, <b>Silver</b>	2		M9592	M9568	
<b>Ford Diesel F250 - 2017-18 - 6" Lift Coil Springs / Variable Rate</b>						
<b>F17651K</b>	6 " Front Coils / Variable Rate	1	F565V			
	Component Box F250 6" w/Pitman Arm Included	1	F17651			21
<b>F17651KS</b>	6 " Front Coils / Variable Rate	1	F565V			
	System Box F250 6" w/Pitman Arm Included	1	F17651S			21
	Rear Leaf Springs, 5"	2	FR175S			<b>NEW!</b>
	<b>Select Required Shock Option F&amp;R Shocks (2) each of desired Series</b>					
	<b>Hydro</b> Series Shock with Red Boot, <b>White</b>	2		H7093	H7068	21
	<b>Nitro</b> Series Gas Shock with Red Boot, <b>White</b>	2		N8093	N8068	
	<b>Black MAX</b> Performance Shock with Black Boot, <b>Black</b>	2		B8593	B8568	
<b>M95</b> Monotube Performance Shock, <b>Silver</b>	2		M9593	M9568		
<b>Ford Diesel F250 - 2017-18 - 8.5" Lift Coil Springs / Variable Rate</b>						
<b>F17852K</b>	8.5 " Front Coils / Variable Rate	1	F585V			
	Component Box 8.5" w/Pitman Arm Included	1	F17852			
	Rear Add A Leafs	1	R3815			
	Front 4 Link conversion All Super Duty 4"-8.5"	1	F58484LU			
<b>F17852KS</b>	8.5 " Front Coils / Variable Rate	1	F585V			
	System Box 8.5" w/Pitman Arm Included	1	F17852S			
	Front 4 Link conversion All Super Duty 4"-8.5"	1	F58484LU			
	Rear Leaf Springs, 7"	2	FR177S			<b>NEW!</b>
<b>Select Required Shock Option F&amp;R Shocks (2) each of desired Series</b>						
	<b>Hydro</b> Series Shock with Red Boot, <b>White</b>	2		H7094	H7089	
	<b>Nitro</b> Series Gas Shock with Red Boot, <b>White</b>	2		N8094	N8089	
	<b>Black MAX</b> Performance Shock with Black Boot, <b>Black</b>	2		B8594	B8589	
	<b>M95</b> Monotube Performance Shock, <b>Silver</b>	2		M9594	M9589	



## 2017-18 Ford F350 Super Duty Pickup

Kit Ref #	Description	Qty	Part #	Front Shock	Rear Shock	Note
<b>Ford Diesel or Gas F350 - 2017-18 - 4" Metal Spacer Kit with Black MAX shocks</b>						
<b>F1740SPB3</b>	4" Complete Front & Rear Kit with Front & Rear <b>Black MAX</b> shocks	1	F1740SPB3	Incl.	Incl.	
<b>Ford Diesel F350 - 2018 - 4" Lift Coil Springs / Variable Rate</b>						
<b>F17451K3</b>	4 " Front Coils / Variable Rate	1	F545V			
	Component Box F350 4"	1	F174513			21
<b>F17451KS</b>	4 " Front Coils / Variable Rate	1	F545V			
	System Box F350 4"	1	F17451S			21
	Rear Leaf Springs, 3"	2	FR173S			<b>NEW!</b>
	<b>Select Required Shock Option F&amp;R Shocks (2) each of desired Series</b>					
	<b>Hydro</b> Series Shock with Red Boot, <b>White</b>	2		H7092	H7068	
	<b>Nitro</b> Series Gas Shock with Red Boot, <b>White</b>	2		N8092	N8068	
	<b>Black MAX</b> Performance Shock with Black Boot, <b>Black</b>	2		B8592	B8568	
	<b>M95</b> Monotube Performance Shock, <b>Silver</b>	2		M9592	M9568	
<b>Ford Diesel F350 - 2017-18 - 6" Lift Coil Springs / Variable Rate</b>						
<b>F17651K3</b>	6 " Front Coils / Variable Rate	1	F565V			
	Component Box F350 6" w/Pitman Arm Included	1	F176513			21
<b>F17651KS</b>	6 " Front Coils / Variable Rate	1	F565V			
	System Box F350 6" w/Pitman Arm Included	1	F17651S			21
	Rear Leaf Springs, 5"	2	FR175S			<b>NEW!</b>
	<b>Select Required Shock Option F&amp;R Shocks (2) each of desired Series</b>					
	<b>Hydro</b> Series Shock with Red Boot, <b>White</b>	2		H7093	H7068	
	<b>Nitro</b> Series Gas Shock with Red Boot, <b>White</b>	2		N8093	N8068	
	<b>Black MAX</b> Performance Shock with Black Boot, <b>Black</b>	2		B8593	B8568	
	<b>M95</b> Monotube Performance Shock, <b>Silver</b>	2		M9593	M9568	
<b>Ford Diesel F350 - 2017-18- 8.5" Lift Coil Springs / Variable Rate</b>						
<b>F17852K</b>	8.5 " Front Coils / Variable Rate	1	F585V			
	Component Box 8.5" w/Pitman Arm Included	1	F17852			
	Rear Add A Leafs	1	R3815			
	Front 4 Link conversion All Super Duty 4"-8.5"	1	F58484LU			
<b>F17852KS</b>	8.5 " Front Coils / Variable Rate	1	F585V			
	System Box 8.5" w/Pitman Arm Included	1	F17852S			
	Front 4 Link conversion All Super Duty 4"-8.5"	1	F58484LU			
	Rear Leaf Springs, 7"	2	FR177S			<b>NEW!</b>
<b>Select Required Shock Option F&amp;R Shocks (2) each of desired Series</b>						
	<b>Hydro</b> Series Shock with Red Boot, <b>White</b>	2		H7094	H7089	
	<b>Nitro</b> Series Gas Shock with Red Boot, <b>White</b>	2		N8094	N8089	
	<b>Black MAX</b> Performance Shock with Black Boot, <b>Black</b>	2		B8594	B8589	
	<b>M95</b> Monotube Performance Shock, <b>Silver</b>	2		M9594	M9589	
<b>Ford Diesel F250/350 - 2017-18</b>						
<b>Options</b>	Front Dual CV Driveshaft	1	F17685DS			23
	Dual Steering Stabilizer <b>White</b> w/Red Boot	1	7254			
	Dual Steering Stabilizer <b>Black Max</b> w/Black Boot	1	8254			
	Dual Steering Stabilizer <b>Silver</b> w/Black Boot	1	9254			
	Front 4 Link conversion All Super Duty 4"-8"	1	F58484LU			
<b>Notes</b>	<b>21)</b> Optional Radius Arm to 4 Link Conversion available Part # F58484LU <b>22)</b> See Wheel & Tire fitment requirements page 238-239 <b>23)</b> Recommended w/6" Lift - Required w/8.5" Lift <b>24)</b> Front Track Bar Bracket Required - Part# TB1120					

NOTE: Many additional applications and steering stabilizers available. See Ford Master Pages 116-155.

# F250/350 LEDUC SERIES

## 2017-18 Ford F250 Super Duty Pickup

Kit Ref #	Description	Qty	Part #	Rear Shock	Note
<b>Ford Diesel/Gas F250 - 2017-18 - 6-8.5" LeDuc Series CoilOvers</b>					
<b>F1761LSK</b>	6" & 8.5" LeDuc Series Front CoilOvers	1	F768FLS		
	6" Front CoilOver Bracket Box	1	F76FLSB		
	Component Box F250 6" w/Pitman Arm Included	1	F17651		
<b>F1761LSKS</b>	6" & 8.5" LeDuc Series Front CoilOvers	1	F768FLS		
	6" Front CoilOver Bracket Box	1	F76FLSB		
	System Box F250 6" w/Pitman Arm Included	1	F17651S		
	Rear Leaf Springs, 5"	2	FR175S		<b>NEW!</b>
<b>F17624LSK</b>	6" & 8.5" LeDuc Series Front CoilOvers	1	F768FLS		
	6" Front CoilOver Bracket Box	1	F76FLSB		
	Component Box F250 6" w/Pitman Arm Included	1	F17651		
	Front 4 Link conversion All Super Duty 4"-8.5"	1	F58484LU		
<b>F17624LSKS</b>	6" & 8.5" LeDuc Series Front CoilOvers	1	F768FLS		
	6" Front CoilOver Bracket Box	1	F76FLSB		
	System Box F250 6" w/Pitman Arm Included	1	F17651S		
	Front 4 Link conversion All Super Duty 4"-8.5"	1	F58484LU		
	Rear Leaf Springs, 5"	2	FR175S		<b>NEW!</b>
<b>Select Required Shock Option F&amp;R Shocks (2) each of desired Series</b>					
	<b>Hydro</b> Series Shock with Red Boot, <b>White</b>	2		H7068	
	<b>Nitro</b> Series Gas Shock with Red Boot, <b>White</b>	2		N8068	
	<b>Black MAX</b> Performance Shock with Black Boot, <b>Black</b>	2		B8568	
	<b>M95</b> Monotube Performance Shock, <b>Silver</b>	2		M9568	
<b>F1782LSK</b>	6" & 8.5" LeDuc Series Front CoilOvers	1	F768FLS		
	8.5" Front CoilOver Bracket Box	1	F78FLSB		
	Component Box 8.5" w/Pitman Arm Included	1	F17852		
	Front 4 Link conversion All Super Duty 4"-8.5"	1	F58484LU		
	Rear Add A Leafs	1	R3815		
<b>F1782LSKS</b>	6" & 8.5" LeDuc Series Front CoilOvers	1	F768FLS		
	8.5" Front CoilOver Bracket Box	1	F78FLSB		
	System Box 8.5" w/Pitman Arm Included	1	F17852S		
	Front 4 Link conversion All Super Duty 4"-8.5"	1	F58484LU		
	Rear Leaf Springs, 7"	2	FR177S		<b>NEW!</b>
<b>Select Required Shock Option F&amp;R Shocks (2) each of desired Series</b>					
	<b>Hydro</b> Series Shock with Red Boot, <b>White</b>	2		H7089	
	<b>Nitro</b> Series Gas Shock with Red Boot, <b>White</b>	2		N8089	
	<b>Black MAX</b> Performance Shock with Black Boot, <b>Black</b>	2		B8589	
	<b>M95</b> Monotube Performance Shock, <b>Silver</b>	2		M9589	

## 2017-18 Ford F350 Super Duty Pickup

Kit Ref #	Description	Qty	Part #	Rear Shock	Note
<b>Ford Diesel/Gas F350 - 2017-18 - 6-8.5" LeDuc Series CoilOvers</b>					
<b>F1761LSK3</b>	6" & 8.5" LeDuc Series Front CoilOvers	1	F768FLS		
	6" Front CoilOver Bracket Box	1	F76FLSB		
	Component Box F350 6" w/Pitman Arm Included	1	F176513		
<b>F17624LSK3</b>	6" & 8.5" LeDuc Series Front CoilOvers	1	F768FLS		
	6" Front CoilOver Bracket Box	1	F76FLSB		
	Component Box F3250 6" w/Pitman Arm Included	1	F176513		
	Front 4 Link conversion All Super Duty 4"-8.5"	1	F58484LU		
<b>F1782LSK</b>	6" & 8.5" LeDuc Series Front CoilOvers	1	F768FLS		
	8.5" Front CoilOver Bracket Box	1	F78FLSB		
	Component Box 8.5" w/Pitman Arm Included	1	F17852		
	Front 4 Link conversion All Super Duty 4"-8.5"	1	F58484LU		
	Rear Add A Leafs	1	R3815		
<b>F1782LSKS</b>	6" & 8.5" LeDuc Series Front CoilOvers	1	F768FLS		
	8.5" Front CoilOver Bracket Box	1	F78FLSB		
	System Box 8.5" w/Pitman Arm Included	1	F17852S		
	Front 4 Link conversion All Super Duty 4"-8.5"	1	F58484LU		
	Rear Leaf Springs, 7"	2	FR177S		NEW!
<b>Ford Diesel F250/350 - 2017-18</b>					
<b>Options</b>	Front Dual CV Driveshaft	1	F17685DS		23
	Dual Steering Stabilizer <b>White</b> w/Red Boot	1	7254		
	Dual Steering Stabilizer <b>Black Max</b> w/Black Boot	1	8254		
	Dual Steering Stabilizer <b>Silver</b> w/Black Boot	1	9254		
<b>Notes</b>	<b>22)</b> See Wheel & Tire fitment requirements page 238-239 <b>23)</b> Recommended w/6" Lift - Required w/8.5" Lift				
NOTE: Many additional applications and steering stabilizers available. See Ford Master Pages 116-155.					



• Use in Conjunction with Existing 6" or 8.5" Suspension Lift

- **2.5" Shock with Massive 2 3/16" O.D. Reservoir**
  - Custom Tuned Front Coil-Over Springs
  - Upper & Lower Coil-Over Shock Brackets
  - Mounting Brackets & Grade 8 Hardware



# TOYOTA



# Tundra



*New Bolt in Skyjacker LeDuc Series coilovers are tuned and tested by Curt LeDuc with application specific valving for maximum performance on and off-road. Purchase as kit or coilover box upgrade for your current Skyjacker Suspension.*



TU762LSKM

## Toyota Tundra Pickup 2007-2018

Kit Ref #	Description	Qty	Part #	Front Shock	Rear Shock	Note
<b>Toyota Tundra 4WD/2WD - 2007-18 - 2" Leveling Kit</b>						
<b>TU720MS</b>	2" Top Mount Leveling Spacer Kit	1	TU720MS			32
<b>Options</b>	<b>Optional Rear Shocks select (2) each desired Series</b>					
	<b>Hydro Series Shock with Red Boot, White</b>	2			H7062	
	<b>Nitro Series Gas Shock with Red Boot, White</b>	2			N8062	
	<b>Black MAX Performance Shock, Black</b>	2			B8562	
	<b>M95 Monotube Performance Shock, Silver</b>	2			M9562	
	1 1/4" Rear Lift Block & U-bolt Kit	1	TU710R			
<b>Toyota Tundra 4WD/2WD - 2007-18- 3" Performance Strut Kit with Rear Hydro Shocks</b>						
<b>TU730STBH</b>	3" Performance Struts, Rear Blocks & U-Bolts w/ 2 Rear Hydro Shocks	1	TU730STBH			32
<b>Toyota Tundra 4WD/2WD - 2007-18 - 3" LeDuc Series Coil-Over Kit with 2 Rear Monotube Shocks</b>						
<b>TU730BM</b>	3" LeDuc Coil-Overs, Rear Blocks & U-Bolts w/ 2 Rear Monotube Shocks	1	TU730BM			32
<b>Toyota Tundra 4WD/2WD - 2007-18 - 3" Performance Strut Lift with Rear Block &amp; U-bolt Kit</b>						
<b>TU730STK</b>	Component Box 3" Performance Struts	1	TU730ST			32
	1 1/4" Rear Lift Block & U-bolt Kit	1	TU710R			
	<b>Select Required Shock Option (2) each of desired Series</b>					
	<b>Hydro Series Shock with Red Boot, White</b>	2			H7062	
	<b>Nitro Series Gas Shock with Red Boot, White</b>	2			N8062	
	<b>Black MAX Performance Shock with Black Boot, Black</b>	2			B8562	
<b>M95 Monotube Performance Shock, Silver</b>	2			M9562		
<b>Toyota Tundra 4WD/2WD - 2007-18 - 3" LeDuc Series FOX Coilover Lift with Rear Block &amp; U-bolt Kit</b>						
<b>TU730K</b>	3" LeDuc Series FOX Coil-Overs w/Mounting Brackets	1	TU730			32
	1 1/4" Rear Lift Block & U-bolt Kit	1	TU710R			
	<b>Select Required Shock Option (2) each of desired Series</b>					
	<b>Hydro Series Shock with Red Boot, White</b>	2			H7062	
	<b>Nitro Series Gas Shock with Red Boot, White</b>	2			N8062	
	<b>Black MAX Performance Shock with Black Boot, Black</b>	2			B8562	
<b>M95 Monotube Performance Shock, Silver</b>	2			M9562		
<b>Toyota Tundra 4WD/2WD - 2007-18 - 4.5" Lift with Rear Block &amp; U-bolt Kit - Black MAX Shocks Incl.</b>						
<b>TU745BKB</b>	Component Box 4.5 - 6"	1	TU746A			32
	Component Box 4.5" w/ Black MAX Shocks	1	TU745BB		Incl.	
<b>Toyota Tundra 4WD/2WD - 2007-18 - 4"-4.5" Lift with Rear Lift Blocks - M95 Monotube Shocks Incl.</b>						
<b>TU745BKM</b>	Component Box 4.5 - 6"	1	TU746A			32
	Component Box 4.5" w/ M95 Monotube Shocks	1	TU745BM		Incl.	
<b>Toyota Tundra 4WD/2WD - 2007-18 - 6" Strut Spacer Lift with Rear Lift Blocks - Black MAX Shocks Incl.</b>						
<b>TU760BKB</b>	Component Box 4.5 - 6"	1	TU746A			32
	Component Box 6" w/ Black MAX Shocks	1	TU760BB		Incl.	
<b>Toyota Tundra - 2007-18 - 6" LeDuc Fox Coilover Front Lift with Rear Add-a-Leaf and M95 Series Performance Monotube Rear Shock</b>						
<b>TU762LSKM</b>	6" LeDuc Series Coilover	1	TU762LS			32
	Component Box 4.5 - 6"	1	TU746A			
	Component Box 6" LeDuc Series w/M95 Monotube Shocks	1	TU762BM		Incl.	
<b>Notes</b>	<b>32) See Wheel &amp; Tire fitment requirements page 238-239</b>					

NOTE: Many additional applications and Steering Stabilizers available. See Toyota Master Pages 178-189



**TU720MS**



**TU730K**



**TU760BKB**



**TU730STK**





# Tacoma



## Tacoma 3" Performance Series Adjustable Strut kit Features

- 1-3" Adjustable Front Struts • Larger 20mm chromed piston rod
- Gas Charged Design • Bonded Iron Piston • Self-Lubricating spherical bearing for longer life
- Rear Blocks & U-Bolts • 2 Rear Shocks Included
- All necessary mounting hardware

**'05-'16 Tacoma 4WD and 2WD Pre-Runner** Skyjacker® has developed a high performance 2.5"-3" suspension lift for the '05-'16 Tacoma 4WD and 2WD Pre-Runner. The lift features Platinum Series front coil-overs with 2" outside diameter shocks and 15" Softride® coil springs, along with all the necessary mounting hardware. The rear lift is achieved using Skyjacker® rear Leaf Springs or Add-A-Leafs.

## 2.5"-3" Platinum Series Tacoma

**System** This 2.5"-3" Coil-Over Lift fits 1995.5 to '04 Toyota Tacoma models for both 4WD & 2WD 'Pre-Runner' models. The System includes full-height replacement Softride® springs for the rear or choose the Kit with Add-a-Leafs. With either, you have the choice of Hydro or Nitro Series Gas shocks for the rear.



## Toyota Tacoma 4WD/2WD 2005-2018

Kit Ref #	Description	Qty	Part #	Rear Shock	Note	
<b>Toyota Tacoma 4WD/2WD - 2005-18 - 2" Leveling Kit</b>						
<b>TT20MS</b>	2005-16 Toyota Tacoma 2" Aluminum Leveling	1	TT20MS		32	
<b>Toyota Tacoma 6-Lug 4WD / 2WD PreRunner- 2016-18 Only 3" Performance Front Strut Kit w/ Rear Block &amp; U-Bolt Kit</b>						
<b>TC536STBH</b>	3" Performance Strut Kit - Includes Performance Front Struts, 2" Block & U-Bolts, Rear E-brake Brackets, Differential Drop Kit, & 2 Rear <b>Hydro</b> Shocks	1	TC536STBH	Incl.	32	
<b>TC536STBN</b>	3" Performance Strut Kit - Includes Performance Front Struts, 2" Block & U-Bolts, Rear E-brake Brackets, Differential Drop Kit, & 2 Rear <b>Nitro</b> Shockss	1	TC536STBN	Incl.		
<b>TC536STBB</b>	3" Performance Strut Kit - Includes Performance Front Struts, 2" Block & U-Bolts, Rear E-brake Brackets, Differential Drop Kit, & 2 Rear <b>Black MAX</b> Shocks	1	TC536STBB	Incl.		
<b>TC536STBM</b>	3" Performance Strut Kit - Includes Performance Front Struts, 2" Block & U-Bolts, Rear E-brake Brackets, Differential Drop Kit, & 2 Rear <b>Monotube</b> Shocks	1	TC536STBM	Incl.		
<b>Toyota Tacoma 6-Lug 4WD / 2WD PreRunner- 2016-18 Only 3" LeDuc Series Coil-Over Kit w/ Rear Block &amp; U-Bolt Kit</b>						
<b>TC536BM</b>	3" LeDuc Coil-Over Kit - Includes Platinum Coil-Overs, 2" Block & U-Bolts, Rear E-brake Brackets, Differential Drop Kit, & 2 Rear <b>Monotube</b> Shocks		TC536BM	Incl.		
<b>Toyota Tacoma 6-Lug 4WD / 2WD PreRunner- 2005-15 Only 3" Performance Front Strut Kit w/ Rear Block &amp; U-Bolt Kit</b>						
<b>TC530STBH</b>	3" Performance Strut Kit - Includes Performance Front Struts, 1.25" Block & U-Bolts, Differential Drop Kit, & 2 Rear <b>Hydro</b> Shocks	1	TC530STBH	Incl.	32	
<b>TC530STBN</b>	3" Performance Strut Kit - Includes Performance Front Struts, 1.25" Block & U-Bolts, Differential Drop Kit, & 2 Rear <b>Nitro</b> Shockss	1	TC530STBN	Incl.		
<b>TC530STBB</b>	3" Performance Strut Kit - Includes Performance Front Struts, 1.25" Block & U-Bolts, Differential Drop Kit, & 2 Rear <b>Black MAX</b> Shocks	1	TC530STBB	Incl.		
<b>TC530STBM</b>	3" Performance Strut Kit - Includes Performance Front Struts, 1.25" Block & U-Bolts, Differential Drop Kit, & 2 Rear <b>Monotube</b> Shocks	1	TC530STBM	Incl.		
<b>Toyota Tacoma 6-Lug 4WD / 2WD PreRunner- 2005-15 Only 3" LeDuc Series Coil-Over Kit w/ Rear Block &amp; U-Bolt Kit</b>						
<b>TC530BM</b>	3" LeDuc Coil-Over Kit - Includes LeDuc Series Coil-Overs, 1.25" Block & U-Bolts, Differential Drop Kit, & 2 Rear <b>Monotube</b> Shocks		TC536BM	Incl.		
<b>Toyota Tacoma 4WD/2WD - 2005-15 - 3" Performance Sturt Lift with Rear Add-a-Leaf</b>						
<b>TC530STK</b>	3" Performance Strut w/Rear Add-a-Leaf	1	TC530ST		32	
	Rear Add-a-Leaf	1	RTC515			
	<b>Select Required Shock Option (2) each of desired Series</b>					
		<b>Hydro</b> Series Shock with Red Boot, <b>White</b>	2		H7045	
		<b>Nitro</b> Series Gas Shock with Red Boot, <b>White</b>	2		N8045	
		<b>Black MAX</b> Performance Shock with Black Boot, <b>Black</b>	2		B8545	
	<b>M95</b> Monotube Performance Shock, <b>Silver</b>	2		M9545		
<b>Toyota Tacoma 4WD/2WD 2005-15 - 3" LeDeuc Series LeDuc Series Fox Coilover Lift with Rear Add-a-Leaf</b>						
<b>TC530K</b>	3" Fox Coilover w/Rear Add-a-Leaf	1	TC530		32	
	Rear Add-a-Leaf	1	RTC515			
	<b>Select Shock Option F&amp;R Shocks (2) each of desired Series</b>					
		<b>Hydro</b> Series Shock with Red Boot, <b>White</b>	2		H7045	
		<b>Nitro</b> Series Gas Shock with Red Boot, <b>White</b>	2		N8045	
		<b>Black MAX</b> Performance Shock with Black Boot, <b>Black</b>	2		B8545	
	<b>M95</b> Monotube Performance Shock, <b>Silver</b>	2		M9545		
<b>Notes</b>	<b>32)</b> See Wheel & Tire fitment requirements page 238-239					

NOTE: Many additional applications and Steering Stabilizers available. See Toyota Master Pages 178-189



**TTU20MS**



**TC530STK**



**TC530KS**



### Toyota Tacoma Pickup 1995.5-04

Kit Ref #	Description	Qty	Part #	Front Shock	Rear Shock	Note
<b>Toyota Tacoma 4WD and 2WD Pre-Runner - 1995.5-04 - 2" Leveling Kit</b>						
TTC20MS	2" Aluminum Leveling Kit		TTC20MS			32
<b>Options</b>	<b>Optional Shocks select (2) each of desired Series</b>					
	Hydro Series Shock with Red Boot, <b>White</b>	2			H7027	
	Nitro Series Gas Shock with Red Boot, <b>White</b>	2			N8027	
	Black MAX Performance Shock with Black Boot, <b>Black</b>	2			B8527	
	M95 Monotube Performance Shock, <b>Silver</b>	2			M9527	
<b>Toyota Tacoma 4WD and 2WD Pre-Runner - 1995.5-04 - 3" Performance Strut Lift with Rear Add-a-Leaf</b>						
<b>TTC30STK</b>	3" Performance Struts with Rear U-Bolts	1	TT430ST			32
	Rear Add-a-Leaf, Pair	1	RTC20			
	<b>Select Required Shock Option (2) each of desired Series</b>					
	Hydro Series Shock with Red Boot, <b>White</b>	2			H7027	
	Nitro Series Gas Shock with Red Boot, <b>White</b>	2			N8027	
	Black MAX Performance Shock with Black Boot, <b>Black</b>	2			B8527	
	M95 Monotube Performance Shock, <b>Silver</b>	2			M9527	
<b>Toyota Tacoma 4WD and 2WD Pre-Runner - 1995.5-04 - 3" Performance Strut Lift with Rear Leaf Springs</b>						
<b>TTC30STKS</b>	3" Performance Struts with Rear U-Bolts	1	TT430ST			32
	Rear Leaf Springs, Each	2	TCR25S			
	<b>Select Required Shock Option (2) each of desired Series</b>					
	Hydro Series Shock with Red Boot, <b>White</b>	2			H7027	
	Nitro Series Gas Shock with Red Boot, <b>White</b>	2			N8027	
	Black MAX Performance Shock with Black Boot, <b>Black</b>	2			B8527	
	M95 Monotube Performance Shock, <b>Silver</b>	2			M9527	
<b>Toyota Tacoma 4WD and 2WD Pre-Runner - 1995.5-04 - 3" Performance Fox Coilover Lift with Rear Add-a-Leaf</b>						
<b>SKTOY30K</b>	3" Performance Coils & Coil-Over Shocks	1	SKTOY30			32
	Rear Add-a-Leaf, Pair	1	RTC20			
	<b>Select Required Shock Option (2) each of desired Series</b>					
	Hydro Series Shock with Red Boot, <b>White</b>	2			H7027	
	Nitro Series Gas Shock with Red Boot, <b>White</b>	2			N8027	
	Black MAX Performance Shock with Black Boot, <b>Black</b>	2			B8527	
	M95 Monotube Performance Shock, <b>Silver</b>	2			M9527	
<b>Toyota Tacoma 4WD and 2WD Pre-Runner - 1995.5-04 - 3" Performance Fox Coilover Lift with Rear Leaf Springs</b>						
<b>SKTOY30KS</b>	3" Performance Coils & Coil-Over Shocks	1	SKTOY30			32
	Rear Leaf Springs, Each	2	TCR25S			
	Rear Component Box	1	UTWR			
	<b>Select Required Shock Option (2) each of desired Series</b>					
	Hydro Series Shock with Red Boot, <b>White</b>	2			H7027	
	Nitro Series Gas Shock with Red Boot, <b>White</b>	2			N8027	
	Black MAX Performance Shock with Black Boot, <b>Black</b>	2			B8527	
	M95 Monotube Performance Shock, <b>Silver</b>	2			M9527	
<b>Notes</b>	<b>32) See Wheel &amp; Tire fitment requirements page 238-239</b>					

NOTE: Many additional applications and Steering Stabilizers available. See Toyota Master Pages 178-189.

# 4Runner



T4330STBB



## 03-18 Toyota 4Runner 4WD / 2WD

### Features

- 1-3" Adjustable Front Struts • Larger 20mm chromed piston rod • Gas Charged Design • Bonded Iron Piston
- Self-Lubricating spherical bearing for longer life • Softride Coil Springs
- 2 Rear Shocks Included • All necessary mounting hardware

### Toyota 4Runner 4WD / 2WD - 2003 - 18

Kit Ref #	Description	Qty	Part #	Rear Shock	Note
<b>Toyota 4Runner 4WD / 2WD - 2003 - 18 2" Front Metal Spacer</b>					
TT20MS	2" Front Metal Spacer		TT20MS		
<b>Toyota 4Runner 4WD / 2WD - 2003 - 18 2" Front / 1.5" Rear Kit</b>					
T420MS	2" Front Metal Spacer, 1.5" Rear Polyurethane Kit		T420MS		
<b>Toyota 4Runner 4WD / 2WD - 2003 - 18 3" Performance Front Strut Kit w/ Rear Coil Springs</b>					
T4330STBH	3" Performance Strut Kit - Includes Performance Front Struts, Rear Coil Springs, Rear Sway Bar End Links, Differential Drop Kit, & 2 Rear <b>Hydro</b> Shocks		T4330STBH	Incl.	
T4330STBN	3" Performance Strut Kit - Includes Performance Front Struts, Rear Coil Springs, Rear Sway Bar End Links, Differential Drop Kit, & 2 Rear <b>Nitro</b> Shocks		T4330STBN	Incl.	
T4330STBB	3" Performance Strut Kit - Includes Performance Front Struts, Rear Coil Springs, Rear Sway Bar End Links, Differential Drop Kit, & 2 Rear <b>Black MAX</b> Shocks		T4330STBB	Incl.	
T4330STBM	3" Performance Strut Kit - Includes Performance Front Struts, Rear Coil Springs, Rear Sway Bar End Links, Differential Drop Kit, & 2 Rear <b>Monotube</b> Shocks		T4330STBM	Incl.	
<b>Toyota 4Runner 4WD / 2WD - 2003 - 18 3" LeDuc Series Front Coil-Over Kit w/ Rear Coil Springs</b>					
T4330BM	3" Platinum Coil-Over Kit - Includes Platinum Coil-Overs, Rear Coil Springs, Rear Sway Bar End Links, Differential Drop Kit, & 2 Rear <b>Monotube</b> Shocks		T4330BM	Incl.	

TTC20MS



TTC30STK



T4330BM

# FJ Cruiser



**Skyjacker® has developed a new 3" Suspension lifts for the '07-'14 FJ Cruiser.** The 3" Performance Strut lift features new performance series struts and the factory coil is maintained. The rear lift on both kits is achieved using Skyjacker® rear Softride® coil springs. These are high performance Skyjacker® Suspensions complete with all the options and the ease of a simple bolt-on installation.

## Toyota FJ Cruiser 2007-2014

Kit Ref #	Description	Qty	Part #	Front Shock	Rear Shock	Note
<b>Toyota FJ Cruiser - 2007-14 - 2" Leveling Kit</b>						
TT20MS	2" Aluminum Leveling Kit		TT20MS			32
Options	<b>Optional - Select Shock (2) each of desired Series</b>					
	Hydro Series Shock with Red Boot, <b>White</b>	2			H7098	
	Nitro Series Gas Shock with Red Boot, <b>White</b>	2			N8098	
<b>Toyota FJ Cruiser - 2007-14 - 2" Metal Spacer Front with 1.5" Poly Spacer Rear Lift</b>						
FJ20MS	2" Metal Front, 1.5" Poly Rear Lift	1	FJ20MS			32
	<b>Select Required Shock Option (2) each of desired Series</b>					
	Hydro Series Shock with Red Boot, <b>White</b>	2			H7098	
	Nitro Series Gas Shock with Red Boot, <b>White</b>	2			N8098	
	Black Max Performance Shock, <b>Black</b>	2			B8598	
	M95 Monotube Performance Shock, <b>Silver</b>				M9598	
FJ730STBH	3" Performance Strut Kit 1 box includes: Adj Front Struts, 2.5" rear coils, sway bar end links and 2 rear <b>Hydro shocks</b>		FJ730STBH		Incl.	
FJ730STBN	3" Performance Strut Kit 1 box includes: Adj Front Struts, 2.5" rear coils, sway bar end links and 2 rear <b>Nitro shocks</b>		FJ730STBN		Incl.	
<b>Toyota FJ Cruiser - 2007-14 - 3" Performance Front Strut with Rear Coil Springs</b>						
FJ730STK	3" Performance Struts, with Coil Springs Rear Lift	1	FJ730ST			
	<b>Select Required Shock Option (2) each of desired Series</b>					
	Hydro Series Shock with Red Boot, <b>White</b>	2			H7098	
	Nitro Series Gas Shock with Red Boot, <b>White</b>	2			N8098	
	Black Max Performance Shock, <b>Black</b>	2			B8598	
	M95 Monotube Performance Shock, <b>Silver</b>	2			M9598	
<b>Toyota FJ Cruiser - 2007-14- 3" LeDuc Series FOX Coil-Over Series</b>						
FJ730K	3" LeDuc Series FOX Coil-Over kit with Softride® rear coil springs	1	FJ730			
	<b>Select Required Shock Option (2) each of desired Series</b>					
	Hydro Series Shock with Red Boot, <b>White</b>	2			H7098	
	Nitro Series Gas Shock with Red Boot, <b>White</b>	2			N8098	
	Black Max Performance Shock, <b>Black</b>	2			B8598	
	M95 Monotube Performance Shock, <b>Silver</b>	2			M9598	
Notes	<b>30)</b> Shackle reversal Options available See Toyota Master Pages 178-189 <b>31)</b> 3" Fox Coilover Option available, See Toyota Master Pages 178-189 <b>32)</b> See Wheel & Tire fitment requirements page 238-239					

# FJ40 Landcruiser



**2.5" and 4" Lifts For '64-'80 Toyota LandCruisers**  
 Skyjacker® offers Softride® 2.5" and 4" Systems for Toyota's stout short wheel based vehicles. Skyjacker® also offers a System for Cruisers with an installed front shackle correction kit which raises the front 1.5". This System includes 2.5" front and 4" rear Softride® springs to level the vehicle

Toyota FJ40 Landcruiser 1964-1980							
Kit Ref #	Description	Qty	Part #	Front Shock	Rear Shock	Note	
<b>Toyota FJ40 Land Cruiser - 1964-80 - 2.5" Lift Front &amp; Rear Leaf Springs &amp; U-Bolts</b>							
<b>L20KS</b>	2.5" Front Leaf Spring each	2	L20FS			30, 32	
	2.5" Rear Leaf Spring each	2	L20RS				
	2.5"-4" Component Box with Front & Rear U-Bolts	1	L24S				
	<b>Select Required Shock Option F&amp;R Shocks (2) each of desired Series</b>						
	<b>Hydro Series Shock with Red Boot, White</b>	2		H7012	H7023		
	<b>Nitro Series Gas Shock with Red Boot, White</b>	2		N8012	N8023		
	<b>Black MAX Performance Shock with Black Boot, Black</b>	2		B8512	B8523		
<b>M95 Monotube Performance Shock, Silver</b>	2		M9512	M9523			
<b>Toyota FJ40 Land Cruiser - 1964-80 - 4" Lift Front &amp; Rear Leaf Springs &amp; U-Bolts</b>							
<b>L40KS</b>	4" Front Leaf Spring each	2	L40FS			30, 32	
	4" Rear Leaf Spring each	2	L40RS				
	2.5"-4" Component Box with Front & Rear U-Bolts	1	L24S				
	<b>Select Required Shock Option (2) each of desired Series</b>						
	<b>Hydro Series Shock with Red Boot, White</b>	2		H7023	H7041		
	<b>Nitro Series Gas Shock with Red Boot, White</b>	2		N8023	N8041		
	<b>Black MAX Performance Shock with Black Boot, Black</b>	2		B8523	B8541		
<b>M95 Monotube Performance Shock, Silver</b>	2		M9523	M9541			
<b>Notes</b>	<b>30)</b> Shackle reversal Options available See Toyota Master Pages 178-189 <b>32)</b> See Wheel & Tire fitment requirements page 238-239						
<b>NOTE: Many additional applications and Steering Stabilizers available. See Toyota Master Pages 178-189</b>							



FJ20MS



L40KS



FJ730STK

# NISSAN Titan



**Skyjacker's new Nissan Titan & Titan XD 2" Aluminum Leveling Spacer** is easy to install and combines great looks with strength while providing 2" of lift. This new spacer features aircraft quality, 6061-T6511 Aluminum offering enhanced durability. This simple design is easy to install with a 100% bolt-on installation process. This simple kit takes out the factory rake and levels the front of your truck with the rear, giving your vehicle an overall more aggressive appearance and room for up to 33" tires.

## 04-17 Nissan Titan

Kit Ref #	Description	Qty	Part #	Front Shock	Rear Shock	Note
<b>Nissan Titan / Titan XD 2" Leveling Kit</b>						
<b>NT20MS</b>	2" Leveling Kit	1	NT20MS			
<b>NT26MSP</b>	2" Leveling Kit with Rear Blocks & U-Bolts	1	NT26MSP			



NT20MS

2" 04-17 Nissan Titan  
2WD/4WD & XD



NT26MSP

2" 16-17 Nissan Titan XD  
(Includes Rear Blocks/U-Bolts)

Application Guide  
 How To Use the Catalog  
 Chevrolet / GM / GMC  
 Dodge / RAM  
 Ford (4WD & 2WD)  
 Honda (4WD)  
 International.  
 Isuzu  
 Jeep (4WD & 2WD)  
 Mazda (4WD & 2WD)  
 Nissan  
 Toyota (4WD & 2WD)  
 Polaris / UTV  
 Shock Application Guide  
 Front Leveling Struts  
 Multiple Shock Kits  
 Shock Specifications Guide  
 Steering Stabilizers  
 Chevrolet / GM Accessories  
 Dodge Accessories  
 Ford Accessories  
 Honda Accessories  
 International Accessories  
 Jeep Accessories  
 Mazda Accessories  
 Toyota Accessories  
 Universal Accessories  
 Polyurethane Clearance Kits / Body Lifts  
 Add-A-Leafs, Softride®  
 Brake Lines, Stainless Steel Braided  
 Coil Springs, Softride®  
 Front Leaf Springs, Softride®  
 Rear Leaf Springs, Softride®  
 Steering Components  
 Rear Lift Blocks & U-Bolt Kits  
 U-Bolts  
 Tire & Wheel Chart

**Skyjacker is your most current avenue for information about Skyjacker® Suspensions & our products. It also features all kinds of cool things you'll want to check out.**

- **Product Search** - Find exactly what you need for your customer's vehicle... quickly & accurately.
- **Skygear** - Select from 'official' merchandise... banners, pennants, decals, shirts, caps, & jackets.
- **Dealer Search** - Become a Skyjacker® Authorized Dealer & we'll steer customers to your door.
- **Real Rides** - Expand your 'showroom' to the world. Post your Skyjacker® equipped vehicles on this high traffic area to show-off your expertise & drive new customers into your area.
- **News** - Review Skyjacker's coverage in the media.
- **Project Vehicles** - Vehicles your customer's want to duplicate.
- **Events** - See where the action is & join the fun.
- **New Products** - Find out 'What's New' as we release it.





LIFT	Quick Kit	KIT NOTES	Component Box <small>(Requires 1 of Each)</small>	Front Springs		Rear Springs		Add-A-Leafs	Steering Correction <small>(Order 1 Each)</small>	Steering Stabilizers						HYDRO Shocks		NITRO Shocks		BLACK MAX		M95 Shocks		Labor Hours	
				Qty	Part #	Qty	Part #			White		Black		Silver		White		Black		Silver					
	Reference							OEM	Single	Dual	OEM	Single	Dual	OEM	Single	Dual	Front	Rear	Front	Rear	Front	Rear	Front	Rear	
<b>NOTE: ALL SHOCKS MUST BE ORDERED SEPARATELY</b>																									
<b>07-13 AVALANCHE 1500 4WD / 2WD (STRUT FRONT END)</b>																									
<b>07-13 Avalanche 1500 4WD / 2WD Kit Lower Metal Spacers (Front Leveling Kit)</b>																									
2"	C1420LMSA	K31	C1420LMSA																						
KIT NOTES: Installs Below Strut Assembly. K31. Part # C12CS Lifts Rear 1.25" if Needed.																									
<b>07-13 Avalanche 1500 4WD / 2WD Kit Upper Metal Spacers (Front Leveling Kit)</b>																									
2"	C720MS	K31	C720MS																						
KIT NOTES: Installs Above Strut Assembly. K31. Part # C12CS Lifts Rear 1.25" if Needed.																									
<b>07-13 Avalanche 1500 4WD Kit Front Strut Spacers &amp; Replacement Rear Coils (Non-Autoride)</b>																									
4"	C7360SK	K23	C7361A+C7360SP+C7361SR																						
6"	C7660SK	K23	C7661A+C7660SP+C7661SR																						
KIT NOTES: K23. OEM Tires & Wheels can be Used.																									
<b>07-13 Avalanche 1500 4WD Kit Performance Struts with Replacement Rear Coils (Non-Autoride)</b>																									
3.5-4"	C7361SK	K23	C7361A+C7361ST+C7361SR																						
6"	C7661SK	K23	C7661A+C7661ST+C7661SR																						
KIT NOTES: K23. OEM Tires & Wheels can be Used.																									
<b>07-13 Avalanche 1500 4WD Kit 6-Lug with Replacement Rear Coils (Autoride)</b>																									
3.5"	C7361ARK	K23	C7361A+C7361AR+C7361SR																						
KIT NOTES: K23. OEM Tires & Wheels can be Used.																									
<b>NOTE: ALL SHOCKS MUST BE ORDERED SEPARATELY</b>																									
<b>02-06 1500 AVALANCHE</b>																									
<b>02-06 Avalanche 1500 (Torsion Bar Front End) Torsion keys (Front Leveling Kit)</b>																									
2"	C101KE		C101KE																						
<b>02-06 Avalanche 1500 4WD System 6-Lug with Replacement Rear Coils</b>																									
3"	C9331K	K16, K23	C9341+C933R																						
KIT NOTES: Does Not Require Removal of the Front Upper Differential Housing Mount. K16. Autoride Models Order Part# C93AR. Factory Shocks will be Retained. K23. OEM Tires & Wheels can be Used.																									
<b>02-06 Avalanche 1500 4WD System 6-Lug with Replacement Rear Coils (Non Autoride)</b>																									
6"	C9631K	K27	C9631A+C9631B																						
KIT NOTES: K27. Not Designed for Autoride Models.																									
<b>NOTE: ALL SHOCKS MUST BE ORDERED SEPARATELY</b>																									
<b>07-14 CADILLAC ESCALADE ESV, EXT 4WD / 2WD (STRUT FRONT END)</b>																									
<b>07-14 Cadillac Escalade ESV, EXT 4WD / 2WD Lower Metal Spacers (Front Leveling Kit)</b>																									
2"	C1420LMSA	K31	C1420LMSA																						
KIT NOTES: Installs Below Strut Assembly. K31. Part # C12CS Lifts Rear 1.25" if Needed.																									
<b>07-14 Cadillac Escalade ESV, EXT 4WD / 2WD Upper Metal Spacers (Front Leveling Kit)</b>																									
2"	C720MS	K31	C720MS																						
KIT NOTES: Installs Above Strut Assembly. K31. Part # C12CS Lifts Rear 1.25" if Needed.																									
<b>07-14 Cadillac Escalade ESV, EXT 4WD System 6-Lug with Replacement Rear Coils (Autoride)</b>																									
3.5"	C7361ARK	K17, K23	C7361A+C7361AR+C7361SR																						
KIT NOTES: K23. OEM Tires & Wheels can be Used. K17. Autoride Shock Relocation Brackets Included.																									
<b>NOTE: ALL SHOCKS MUST BE ORDERED SEPARATELY</b>																									
<b>02-06 CADILLAC ESCALADE (TORSION BAR FRONT END)</b>																									
<b>02-06 Cadillac Escalade ESV, EXT 4WD / 2WD Torsion Keys (Front Leveling Kit)</b>																									
2"	C101KE		C101KE																						
<b>NOTE: ALL SHOCKS MUST BE ORDERED SEPARATELY</b>																									
<b>02-06 CADILLAC ESCALADE ESV, EXT 4WD</b>																									
<b>02-06 Cadillac Escalade ESV, EXT 4WD System 6-Lug with Replacement Rear Coils (Autoride)</b>																									
3"	C933PAK	K17, K23	C933PA+C933PAR																						
KIT NOTES: Does Not Require Removal of the Front Upper Differential Housing Mount. K17. Autoride Shock Relocation Brackets Included. K23. OEM Tires & Wheels can be Used.																									
<b>NOTE: ALL SHOCKS MUST BE ORDERED SEPARATELY</b>																									
<b>15-18 COLORADO / CANYON 4WD / 2WD</b>																									
<b>15-18 COLORADO / CANYON 4WD / 2WD 1" or 2" Front Leveling Kit</b>																									
1"-2"	CC12MS		CC12MS																						
<b>NOTE: ALL SHOCKS MUST BE ORDERED SEPARATELY</b>																									
<b>04-12 COLORADO / CANYON 4WD (TORSION BAR FRONT END)</b>																									
<b>04-12 Colorado / Canyon 4WD Torsion Keys (Front Leveling Kit)</b>																									
2"	C104KE		C104KE																						
<b>NOTE: ALL SHOCKS MUST BE ORDERED SEPARATELY</b>																									
<b>04-12 COLORADO / CANYON 4WD (TORSION BAR FRONT END)</b>																									
<b>04-12 Colorado / Canyon 4WD Kit with Rear Add-A-Leafs</b>																									
4"	CC409K	K2, K24	CC409																						
KIT NOTES: K2. Includes Brake Line Brackets. K24. Can NOT Re-Use OEM Wheels. REQUIRES 4.75" Back Spacing on Wheels.																									



LIFT	Quick Kit	KIT NOTES	Component Box (Requires 1 of Each)	Front Springs		Rear Springs		Add-A-Leafs	Steering Correction (Order 1 Each)	Steering Stabilizers						HYDRO Shocks		NITRO Shocks		BLACK MAX		M95 Shocks		Labor Hours
				Qty	Part #	Qty	Part #			White		Black		Silver		White		Black		Silver				
	OEM			Single	Dual	OEM	Single			Dual	OEM	Single	Dual	OEM	Single	Dual	Front	Rear	Front	Rear	Front	Rear	Front	

**Fits Models Equipped with OE CAST STEEL Knuckles only**

2014 - April 2016 GM 1500 Pick Up 4WD / 2WD Kit (Steel Suspension)

**LeDuc Series Coil-Over System**

6-7"	C14662LSKM	K33, K34	C7146LS+C14661A+C14661PRM																				Included	8
------	------------	----------	---------------------------	--	--	--	--	--	--	--	--	--	--	--	--	--	--	--	--	--	--	--	----------	---

KIT NOTES: K33. OEM Wheels can be Used, Except OEM 18" Wheels will Require Optional Wheel Spacer Kit (Part # WSP655).  
K34. If Driveline vibration occurs, order front driveshaft part # GM10146DS.

**14-18 1500 PICKUP 4WD / 2WD (STRUT FRONT END)**

**NOTE: ALL SHOCKS MUST BE ORDERED SEPARATELY**

Models Built May 2016-2017 (Equipped with STAMPED STEEL A-ARMS only)

Models Built 2014-April 2016 (Equipped with OE ALUMINUM Knuckles only)

14-18 1500 Pickup 4WD / 2WD Kit

**Front Strut Spacers with Blocks & U-Bolts**

4"	C14460APK	K23	C14461AAL+C14460SP+C7361PR																						
6-7"	C14660APK	K33, K34	C14661AAL+C14660SP+C14661PR																						

14-17 1500 Pickup 4WD / 2WD Kit

**Front Strut Spacers with Rear Springs**

6-7"	C14660APKS	K33, K34	C14661AAL+C14660SP+C7661PRS			2	CR55S																			
------	------------	----------	-----------------------------	--	--	---	-------	--	--	--	--	--	--	--	--	--	--	--	--	--	--	--	--	--	--	--

Models Built 2014-April 2016 (Equipped with OE CAST STEEL Knuckles only)

14-16 1500 Pickup 4WD / 2WD Kit

**Front Strut Spacers with Blocks & U-Bolts**

4"	C14460PK	K23	C14461A+C14460SP+C7361PR																						
6-7"	C14660PK	K33, K34	C14661A+C14660SP+C14661PR																						

14-16 1500 Pickup 4WD / 2WD Kit

**Front Strut Spacers with Replacement Rear Springs**

6-7"	C14660PKS	K33, K34	C14661A+C14660SP+C7661PRS			2	CR55S																			
------	-----------	----------	---------------------------	--	--	---	-------	--	--	--	--	--	--	--	--	--	--	--	--	--	--	--	--	--	--	--

KIT NOTES: K23. OEM Tires & Wheels can be Used. K33. OEM Wheels can be Used, Except OEM 18" Wheels will Require Optional Wheel Spacer Kit (Part # WSP655).  
K34. If Driveline vibration occurs, order front driveshaft part # GM10146DS.

**07-13 1500 PICKUP 4WD / 2WD (STRUT FRONT END)**

**NOTE: ALL SHOCKS MUST BE ORDERED SEPARATELY**

07-13 1500 Pickup 4WD / 2WD Kit

**Lower Metal Spacers (Front Leveling Kit)**

2"	C1420LMSA		C1420LMSA																							
----	-----------	--	-----------	--	--	--	--	--	--	--	--	--	--	--	--	--	--	--	--	--	--	--	--	--	--	--

KIT NOTES: Installs Below Strut Assembly.

07-13 1500 Pickup 4WD / 2WD Kit

**Metal Spacers (Front Leveling Kit)**

2"	C720MS		C720MS																							
----	--------	--	--------	--	--	--	--	--	--	--	--	--	--	--	--	--	--	--	--	--	--	--	--	--	--	--

KIT NOTES: Installs Above Strut Assembly.

07-13 1500 Pickup 4WD / 2WD Kit

**Front Strut Spacers with Blocks & U-Bolts**

4"	C7360PK	K23	C7361A+C7360SP+C7361PR																							
6"	C7660PK	K23, K34	C7661A+C7660SP+C7661PR																							

07-13 K1500 Pickup 4WD / 2WD System

**Front Strut Spacers with Replacement Rear Springs**

6"	C7660PKS	K23, K34	C7661A+C7660SP+C7661PRS			2	CR55S																			
----	----------	----------	-------------------------	--	--	---	-------	--	--	--	--	--	--	--	--	--	--	--	--	--	--	--	--	--	--	--

07-13 1500 Pickup 4WD / 2WD Kit

**Performance Struts with Blocks & U-Bolts**

4"	C7361PK	K23	C7361A+C7361ST+C7361PR																							
6"	C7661PK	K23, K34	C7661A+C7661ST+C7661PR																							

07-13 K1500 Pickup 4WD / 2WD System

**Performance Struts with Replacement Rear Springs**

6"	C7661PKS	K23, K34	C7661A+C7661ST+C7661PRS			2	CR55S																			
----	----------	----------	-------------------------	--	--	---	-------	--	--	--	--	--	--	--	--	--	--	--	--	--	--	--	--	--	--	--

KIT NOTES: K23. OEM Tires & Wheels can be Used.

**LEDUC SERIES COIL-OVER KIT**

07-13 K1500 Pickup 4WD / 2WD System

**Coil-Over Kit with Rear Blocks & U-Bolts**

6"	C7662LSKM	K34	C7146LS + C7661A + C7661PRM																							
----	-----------	-----	-----------------------------	--	--	--	--	--	--	--	--	--	--	--	--	--	--	--	--	--	--	--	--	--	--	--

Kit includes front Fox 2.5" remote reservoir coilover shocks w/ coil springs, front steering knuckles, front & rear cross members, front differential skid plate, front differential relocation brackets, front CV-axle spacers, front sway bar end links & relocation brackets, front brake lines, rear brake line relocation bracket, rear emergency cable relocation bracket, rear blocks, rear U-bolts, & rear M95 monotube shocks. No tie rod modification required. K34 • 10-13 Frt DSaft GM10146DS



LIFT	Quick Kit	KIT NOTES	Component Box <i>(Requires 1 of Each)</i>	Front Springs		Rear Springs		Add-A-Leafs	Steering Correction <i>(Order 1 Each)</i>	Steering Stabilizers						HYDRO Shocks		NITRO Shocks		BLACK MAX		M95 Shocks		Labor Hours			
				Qty	Part #	Qty	Part #			White		Black		Silver		White		White		Black		Silver					
	Reference							OEM	Single	Dual	OEM	Single	Dual	OEM	Single	Dual	Front	Rear	Front	Rear	Front	Rear	Front	Rear			
<b>11-18 2500HD 4WD 8-LUG (TORSION BAR FRONT END)</b>										<b>NOTE: ALL SHOCKS MUST BE ORDERED SEPARATELY</b>																	
<b>11-18 2500HD 4WD</b>			<b>Torsion Keys (Front Leveling Kit)</b>																								
2"	C115KE		C115KE							7011		N/A	8011		N/A	9011		N/A	-----	H7027	-----	N8027	-----	B8527	-----	M9527	2
KIT NOTES: Includes Front Shock Extension Spacers.																											
<b>11-18 2500HD Pickup 4WD / 2WD Kit</b>			<b>K2500HD 8-Lug with Blocks &amp; U-Bolts</b>																								
6"	C11680K		C1168A+C1178B+C1178N							7011		7211	8011		8211	9011		9211			Included	Included					9
7"	C11781K		C1178A+C1178B+C1178N+C1178TR							7011		7211	8011		8211	9011		9211			Included	Included					9
KIT NOTES: OEM 17"-18" Wheels can be Used. DEF / Urea Tank Skid Plate Available. Part # <b>DEFG114SP</b> . In the Event of Rear Driveline Vibration Use Carrier Bearing Lowering Kit # <b>CBL2500</b> . K25.																											
<b>11-18 3500HD 4WD 8-LUG (TORSION BAR FRONT END)</b>										<b>NOTE: ALL SHOCKS MUST BE ORDERED SEPARATELY</b>																	
<b>11-18 3500HD 4WD</b>			<b>Torsion Keys (Front Leveling Kit)</b>																								
2"	C115KE		C115KE							7011		N/A	8011		N/A	9011		N/A	-----	H7027	-----	N8027	-----	B8527	-----	M9527	2
KIT NOTES: Includes Front Shock Extension Spacers.																											
<b>11-18 3500HD Pickup 4WD / 2WD Kit</b>			<b>K2500HD 8-Lug with Blocks &amp; U-Bolts</b>																								
6"	C11680KH		C1168A+C1178BH+C1178N							7011		7211	8011		8211	9011		9211			Included	Included					9
7"	C11781KH		C1178A+C1178BH+C1178N+C1178TR							7011		7211	8011		8211	9011		9211			Included	Included					9
KIT NOTES: OEM 17"-18" Wheels can be Used. DEF / Urea Tank Skid Plate Available. Part # <b>DEFG114SP</b> . In the Event of Rear Driveline Vibration Use Carrier Bearing Lowering Kit # <b>CBL2500</b> .																											
<b>01-10 2500HD / 3500HD 4WD / 2WD 8-LUG (TORSION BAR FRONT END)</b>										<b>NOTE: ALL SHOCKS MUST BE ORDERED SEPARATELY</b>																	
<b>01-10 2500HD / 3500HD 4WD / 2WD</b>			<b>Torsion Keys (Front Leveling Kit)</b>																								
2"	C102KE		C102KE							7098			8098			9098			H7019	H7017	N8019	N8017	B8519	B8517	M9519	M9517	2
KIT NOTES: C102KE Fits Factory Color Codes: Purple, Blue, Yellow. Includes Front Shock Extension Brackets.																											
<b>01-10 2500HD / 3500HD 4WD / 2WD</b>			<b>Torsion Keys (Front Leveling Kit)</b>																								
2"	C103KE		C103KE																H7019	H7017	N8019	N8017	B8519	B8517	M9519	M9517	2
KIT NOTES: C103KE Fits Factory Color Codes: Orange, Green, White, Brown. Includes Front Shock Extension Brackets.																											
<b>01-10 2500HD / 3500HD PICKUP 4WD 8-LUG (TORSION BAR FRONT END)</b>										<b>NOTE: ALL SHOCKS MUST BE ORDERED SEPARATELY</b>																	
<b>01-10 2500HD / 3500HD Pickup 4WD Kit</b>			<b>With Blocks &amp; U-Bolts</b>																								
3"	C9381K	K21, K28	C9381+BUK2082F							7098		7298 <sup>(K)</sup>	8098		8298 <sup>(K)</sup>	9098		9298 <sup>(K)</sup>	H7074	H7017	N8074	N8017	B8574	B8517	M9574	M9517	8
KIT NOTES: <b>Can Re-Use OEM Wheels by Re-Routing Brake &amp; ABS Line. (3" Lift Only).</b> K21. 3500 Models will Require Custom Rear U-Bolts & Modification to Knuckles. K28. Minor Modifications Required on all Duramax Diesel Models.																											
<b>01-10 2500HD / 3500HD Pickup 4WD Kit</b>			<b>With Blocks &amp; U-Bolts</b>																								
6"	C9681K-NSP	K18, K21, K28	C9681A-NSP+C9682B							7098		7298 <sup>(K)</sup>	8098		8298 <sup>(K)</sup>	9098		9298 <sup>(K)</sup>	H7074	H7036	N8074	N8036	B8574	B8536	M9574	M9536	9
KIT NOTES: K18. CANNOT Re-Use OEM Wheels. REQUIRES 4" Back Spacing on Wheels. K21. 3500 Models will Require Custom Rear U-Bolts & Modification to Knuckles. K28. Minor Modifications Required on all Duramax Diesel Models.																											
<b>01-10 2500HD Pickup 4WD System</b>			<b>With Replacement Rear Springs</b>																								
6"	C9681KS-NSP	K15, K18, K28	C9681A-NSP+C9682BS			2	CR75S			7098		7298 <sup>(K)</sup>	8098		8298 <sup>(K)</sup>	9098		9298 <sup>(K)</sup>	H7074	H7036	N8074	N8036	B8574	B8536	M9574	M9536	9
KIT NOTES: K15. Minor Modifications may be Required on Duramax Models. K18. CANNOT Re-Use OEM Wheels. REQUIRES 4" Back Spacing on Wheels. K28. Minor Modifications Required on all Duramax Diesel Models.																											
<b>73-87 CHEVY / GMC PICKUP 4WD</b>										<b>NOTE: ALL SHOCKS MUST BE ORDERED SEPARATELY</b>																	
<b>73-87 Chevy / GMC K10 Pickup 4WD Kit</b>			<b>With Blocks &amp; U-Bolts &amp;/or Add-A-Leafs</b>																								
2.5"	C125AK	K10	C125A	2	C125S				CA50	7055		7220	8055		8220	9055		9220	H7051	H7053	N8051	N8053	B8551	B8553	M9551	M9553	4
4"	C140AK	K6, K7, K10, K22	C140A	2	C140S				CA100	7055		7220	8055		8220	9055		9220	H7051	H7053	N8051	N8053	B8551	B8553	M9551	M9553	4
6"	C160AK	K3, K4, K6, K7, K22	C168A	2	C160S				CA100	7055		7220	8055		8220	9055		9220	H7071	H7073	N8071	N8073	B8571	B8573	M9571	M9573	6
8"	C180AK	K3, K4, K6, K7, K22	C168A	2	C180S			R1120	CA50+CA100	7055		7220	8055		8220	9055		9220	H7071	H7073	N8071	N8073	B8571	B8573	M9571	M9573	7
KIT NOTES: K3. Driveline / Exhaust Modifications may be Necessary. K4. Transfer Case Lowering Kit # TCL15 may be Needed. K6. Optional 4" Offset Drag Link Available - # GMDL4. K7. See Brake Lines Section. K10. Fitted Leafs are Available for Additional Weight Capacity (Heavy Winch Bumper, Big Block or Diesel Engine, Etc.). See Leaf Springs Section. K22. If Vehicle is Equipped with a Front Sway Bar, Lowering Brackets must be Ordered. See Chevrolet / GM Accessories.																											

LIFT	Quick Kit	KIT NOTES	Component Box (Requires 1 of Each)	Front Springs				Rear Springs				Add-A-Leafs	Steering Correction (Order 1 Each)	Steering Stabilizers						HYDRO Shocks		NITRO Shocks		BLACK MAX		M95 Shocks		Labor Hours		
				White		Black		Silver		White				White		Black		Silver												
	OEM			Single	Dual	OEM	Single	Dual	OEM	Single	Dual			OEM	Single	Dual	Front	Rear	Front	Rear	Front	Rear	Front	Rear	Front	Rear				
<b>73-87 Chevy / GMC K10 Pickup 4WD System With Replacement Rear Springs</b>																														
2.5"	C125AKS	K10	C124AS	2	C125S	2	CR12S				CA50		7055		7220	8055		8220	9055		9220	H7051	H7053	N8051	N8053	B8551	B8553	M9551	M9553	6
4"	C140AKS	K6, K7, K10, K22	C124AS	2	C140S	2	CR14S				CA100		7055		7220	8055		8220	9055		9220	H7051	H7053	N8051	N8053	B8551	B8553	M9551	M9553	6
6"	C160AKS	K3, K4, K6, K7, K10, K22	C168AS	2	C160S	2	CR16S				CA100		7055		7220	8055		8220	9055		9220	H7071	H7073	N8071	N8073	B8571	B8573	M9571	M9573	7
8"	C180AKS	K3, K4, K6, K7, K10, K22	C168AS	2	C180S	2	CR18S				CA50+CA100		7055		7220	8055		8220	9055		9220	H7071	H7073	N8071	N8073	B8571	B8573	M9571	M9573	7

KIT NOTES: K3. Driveline / Exhaust Modifications may be Necessary. K4. Transfer Case Lowering Kit # TCL15 may be Needed. K6. Optional 4" Offset Drag Link Available - # GMDL4. K7. See Brake Lines Section. K10. Fitted Leafs are Available for Additional Weight Capacity (Heavy Winch Bumper, Big Block or Diesel Engine, Etc.). See Leaf Springs Section. K22. If Vehicle is Equipped with a Front Sway Bar, Lowering Brackets must be Ordered. See Chevrolet / GM Accessories.

<b>73-87 Chevy / GMC K20 Pickup 4WD Kit With Blocks &amp; U-Bolts &amp;/or Add-A-Leafs</b>																														
2.5"	C125BK	K10	C125B	2	C125S						CA50		7055		7220	8055		8220	9055		9220	H7051	H7053	N8051	N8053	B8551	B8553	M9551	M9553	4
4"	C140BK	K6, K7, K10, K22	C140B	2	C140S						CA100		7055		7220	8055		8220	9055		9220	H7051	H7053	N8051	N8053	B8551	B8553	M9551	M9553	4
6"	C160BK	K3, K4, K6, K7, K10, K22	C168B	2	C160S						CA100		7055		7220	8055		8220	9055		9220	H7071	H7073	N8071	N8073	B8571	B8573	M9571	M9573	6
8"	C180BK	K3, K4, K6, K7, K10, K22	C168B	2	C180S				R1120		CA50+CA100		7055		7220	8055		8220	9055		9220	H7071	H7073	N8071	N8073	B8571	B8573	M9571	M9573	7

KIT NOTES: K3. Driveline / Exhaust Modifications may be Necessary. K4. Transfer Case Lowering Kit # TCL15 may be Needed. K6. Optional 4" Offset Drag Link Available - # GMDL4. K7. See Brake Lines Section. K10. Fitted Leafs are Available for Additional Weight Capacity (Heavy Winch Bumper, Big Block or Diesel Engine, Etc.). See Leaf Springs Section. K22. If Vehicle is Equipped with a Front Sway Bar, Lowering Brackets must be Ordered. See Chevrolet / GM Accessories.

<b>73-87 CHEVY / GMC PICKUP 4WD</b>													<b>NOTE: ALL SHOCKS MUST BE ORDERED SEPARATELY</b>																	
<b>73-87 Chevy / GMC K20 Pickup 4WD System With 52" Replacement Rear Springs</b>																														
2.5"	C125BKS	K10	C124BS	2	C125S	2	CR12S				CA50		7055		7220	8055		8220	9055		9220	H7051	H7053	N8051	N8053	B8551	B8553	M9551	M9553	6
4"	C140BKS	K5, K6, K7, K10, K22	C124BS	2	C140S	2	CR14S				CA100		7055		7220	8055		8220	9055		9220	H7051	H7053	N8051	N8053	B8551	B8553	M9551	M9553	6
6"	C160BKS	K3, K4, K5, K6, K7, K10, K22	C168BS	2	C160S	2	CR16S				CA100		7055		7220	8055		8220	9055		9220	H7071	H7073	N8071	N8073	B8571	B8573	M9571	M9573	7
8"	C180BKS	K3, K4, K5, K6, K7, K10, K22	C168BS	2	C180S	2	CR18S				CA50+CA100		7055		7220	8055		8220	9055		9220	H7071	H7073	N8071	N8073	B8571	B8573	M9571	M9573	7

KIT NOTES: K3. Driveline / Exhaust Modifications may be Necessary. K4. Transfer Case Lowering Kit # TCL15 may be Needed. K5. Must have 3-Bolt Steering Knuckle. (If Your Vehicle has a 4 Bolt Closed Knuckle use GMDL4 Not CA100). K6. Optional 4" Offset Drag Link Available - # GMDL4. K7. See Brake Lines Section. K10. Fitted Leafs are Available for Additional Weight Capacity (Heavy Winch Bumper, Big Block or Diesel Engine, Etc.). See Leaf Springs Section. K22. If Vehicle is Equipped with a Front Sway Bar, Lowering Brackets must be Ordered. See Chevrolet / GM Accessories.

<b>73-87 Chevy / GMC K20 Pickup 4WD System With 56" Replacement Rear Springs</b>																														
4"	C140BKSD	K5, K6, K7, K10, K22	C124BS	2	C140S	2	CR24S				CA100		7055		7220	8055		8220	9055		9220	H7051	H7053	N8051	N8053	B8551	B8553	M9551	M9553	6
6"	C160BKSD	K3, K4, K5, K6, K7, K10, K22	C168BS	2	C160S	2	CR26S				CA100		7055		7220	8055		8220	9055		9220	H7071	H7073	N8071	N8073	B8571	B8573	M9571	M9573	7
8"	C180BKSD	K5, K7, K9	C180BSD	2	C180S	2	CR26S				CA50+CA100		7055		7220	8055		8220	9055		9220	H7071	H7073	N8071	N8073	B8571	B8573	M9571	M9573	7

KIT NOTES: K3. Driveline / Exhaust Modifications may be Necessary. K4. Transfer Case Lowering Kit # TCL15 may be Needed. K5. Must have 3-Bolt Steering Knuckle. (If Your Vehicle has a 4 Bolt Closed Knuckle Use GMDL4 Not CA100). K6. Optional 4" Offset Drag Link Available - # GMDL4. K7. See Brake Lines Section. K9. This Lift also Includes 2" Blocks. K10. Fitted Leafs are Available for Additional Weight Capacity (Heavy Winch Bumper, Big Block or Diesel Engine, Etc.). See Leaf Springs Section. K22. If Vehicle is Equipped with a Front Sway Bar, Lowering Brackets must be Ordered. See Chevrolet / GM Accessories.

<b>77-87 Chevy / GMC K30 Pickup 4WD Kit With Blocks &amp; U-Bolts &amp;/or Add-A-Leafs</b>																														
2.5"	C125CK	K10	C125C	2	C125S						CA50		7055		7255	8055		8255	9055		9255	H7051	H7073	N8051	N8073	B8551	B8573	M9551	M9573	5
4"	C140CK	K6, K7, K10, K22	C140C	2	C140S						CA50		7055		7255	8055		8255	9055		9255	H7051	H7073	N8051	N8073	B8551	B8573	M9551	M9573	5
6"	C160CK	K3, K4, K6, K7, K10, K22	C168C	2	C160S						CA50+SB60		7055		7255	8055		8255	9055		9255	H7071	H7078	N8071	N8078	B8571	B8578	M9571	M9578	6
8"	C180CK	K3, K4, K6, K7, K10, K22	C168C	2	C180S				R1120		CA50+SB60		7055		7255	8055		8255	9055		9255	H7071	H7078	N8071	N8078	B8571	B8578	M9571	M9578	7

KIT NOTES: K3. Driveline / Exhaust Modifications may be Necessary. K4. Transfer Case Lowering Kit # TCL15 may be Needed. K6. Optional 4" Offset Drag Link Available - # GMDL4. K7. See Brake Lines Section. K10. Fitted Leafs are Available for Additional Weight Capacity (Heavy Winch Bumper, Big Block or Diesel Engine, Etc.). See Leaf Springs Section. K22. If Vehicle is Equipped with a Front Sway Bar, Lowering Brackets must be Ordered. See Chevrolet / GM Accessories.

<b>77-87 Chevy / GMC K30 Pickup 4WD System With Replacement Rear Springs</b>																														
4"	C140CKS	K6, K7, K10, K22	C124CS	2	C140S	2	CR24S				CA50		7055		7255	8055		8255	9055		9255	H7051	H7073	N8051	N8073	B8551	B8573	M9551	M9573	6
6"	C160CKS	K3, K4, K6, K7, K10, K22	C160CS	2	C160S	2	CR26S				CA50+SB60		7055		7255	8055		8255	9055		9255	H7071	H7078	N8071	N8078	B8571	B8578	M9571	M9578	7
8"	C180CKS	K7, K9	C180CS	2	C180S	2	CR26S				CA50+SB60		7055		7255	8055		8255	9055		9255	H7071	H7078	N8071	N8078	B8571	B8578	M9571	M9578	7

KIT NOTES: K3. Driveline / Exhaust Modifications may be Necessary. K4. Transfer Case Lowering Kit # TCL15 may be Needed. K6. Optional 4" Offset Drag Link Available - # GMDL4. K7. See Brake Lines Section. K9. This Lift also Includes 2" Blocks. K10. Fitted Leafs are Available for Additional Weight Capacity (Heavy Winch Bumper, Big Block or Diesel Engine, Etc.). See Leaf Springs Section. K22. If Vehicle is Equipped with a Front Sway Bar, Lowering Brackets must be Ordered. See Chevrolet / GM Accessories.

<b>67-72 CHEVY / GMC PICKUP 4WD</b>													<b>NOTE: ALL SHOCKS MUST BE ORDERED SEPARATELY</b>																	
<b>67-72 Chevy / GMC K10 Pickup 4WD Kit With Blocks &amp; U-Bolts &amp;/or Add-A-Leafs</b>																														
2.5"	C225AK		C225A	2	C225S						CA50		7055		7220	8055		8220	9055		9220	H7051	H7041	N8051	N8041	B8551	B8541	M9551	M9541	4
4"	C240AK	K5, K6, K22	C240A	2	C240S						CA100		7055		7220	8055		8220	9055		9220	H7051	H7041	N8051	N8041	B8551	B8541	M9551	M9541	4
6"	C260AK	K2, K5, K6, K22	C268A	2	C260S						CA100		7055		7220	8055		8220	9055		9220	H7071	H7060	N8071	N8060	B8571	B8560	M9571	M9560	6
8"	C280AK	K2, K3, K5, K6, K22	C268A	2	C280S				R1120		CA50+CA100		7055		7220	8055		8220	9055		9220	H7071	H7060	N8071	N8060	B8571	B8560	M9571	M9560	7

KIT NOTES: K2. Includes Brake Line Brackets. K3. Driveline / Exhaust Modifications may be Necessary. K5. Must have 3-Bolt Steering Knuckle. (If your Vehicle has a 4 Bolt Closed Knuckle Use GMDL4 Not CA100). K6. Optional 4" Offset Drag Link Available - # GMDL4. K22. If Vehicle is Equipped with a Front Sway Bar, Lowering Brackets must be Ordered. See Chevrolet / GM Accessories.

LIFT	Quick Kit	KIT NOTES	Component Box (Requires 1 of Each)	Front Springs		Rear Springs		Add-A-Leafs	Steering Correction (Order 1 Each)	Steering Stabilizers						HYDRO Shocks		NITRO Shocks		BLACK MAX		M95 Shocks		Labor Hours
				Qty	Part #	Qty	Part #			White		Black		Silver		White		Black		Silver				
	Reference		White	Black	Silver	White	White	Black	Silver	Front	Rear	Front	Rear	Front	Rear	Front	Rear	Front	Rear					
<b>69-72 Chevy / GMC K10 Pickup 4WD System With 52" Replacement Rear Springs</b>																								
2.5"	C225AKS		C224AS	2	C225S	2	CR12S		CA50	7055	7220	8055	8220	9055	9220	H7051	H7041	N8051	N8041	B8551	B8541	M9551	M9541	6
4"	C240AKS	K5, K6, K7, K22	C224AS	2	C240S	2	CR14S		CA100	7055	7220	8055	8220	9055	9220	H7051	H7041	N8051	N8041	B8551	B8541	M9551	M9541	6
6"	C260AKS	K2, K5, K6, K7, K22	C268AS	2	C260S	2	CR16S		CA100	7055	7220	8055	8220	9055	9220	H7071	H7060	N8071	N8060	B8571	B8560	M9571	M9560	7
8"	C280AKS	K2, K3, K5, K6, K7, K22	C268AS	2	C280S	2	CR18S		CA50+CA100	7055	7220	8055	8220	9055	9220	H7071	H7060	N8071	N8060	B8571	B8560	M9571	M9560	7

KIT NOTES: K2. Includes Brake Line Brackets. K3. Driveline / Exhaust Modifications may be Necessary. K5. Must have 3-Bolt Steering Knuckle. K6. Optional 4" Offset Drag Link Available - # GMDL4. K7. See Brake Lines Section. K22. If Vehicle is Equipped with a Front Sway Bar, Lowering Brackets must be Ordered. See Chevrolet / GM Accessories.

**69-72 CHEVY / GMC PICKUP 4WD**

**NOTE: ALL SHOCKS MUST BE ORDERED SEPARATELY**

<b>69-72 Chevy / GMC K10 Pickup 4WD System With 56" Replacement Rear Springs</b>																								
4"	C240AKSD	K5, K6, K7, K22	C224AS	2	C240S	2	CR24S		CA100	7055	7220	8055	8220	9055	9220	H7051	H7041	N8051	N8041	B8551	B8541	M9551	M9541	6
6"	C260AKSD	K2, K5, K6, K7, K22	C268AS	2	C260S	2	CR26S		CA100	7055	7220	8055	8220	9055	9220	H7071	H7060	N8071	N8060	B8571	B8560	M9571	M9560	7
8"	C280AKSD	K2, K3, K5, K6, K7, K9, K22	C280ASD	2	C280S	2	CR26S		CA50+CA100	7055	7220	8055	8220	9055	9220	H7071	H7060	N8071	N8060	B8571	B8560	M9571	M9560	7

KIT NOTES: K2. Includes Brake Line Brackets. K3. Driveline / Exhaust Modifications may be Necessary. K5. Must have 3-Bolt Steering Knuckle. K6. Optional 4" Offset Drag Link Available - # GMDL4. K7. See Brake Lines Section. K9. This Lift also Includes 2" Blocks. K22. If Vehicle is Equipped with a Front Sway Bar. Lowering Brackets must be Ordered. See Accessories Section of catalog.

**07-13 TAHOE / YUKON 4WD (STRUT FRONT END)**

**NOTE: ALL SHOCKS MUST BE ORDERED SEPARATELY**

<b>07-13 Tahoe / Yukon 1500 4WD / 2WD Kit Lower Metal Spacers (Front Leveling Kit)</b>																									
2"	C1420LMSA	K31	C1420LMSA																						

KIT NOTES: Installs Below Strut Assembly. K31. Part # C12CS Lifts Rear 1.25" if Needed.

<b>07-13 Tahoe / Yukon 1500 4WD / 2WD KIT Metal Spacers (Front Leveling Kit)</b>																									
2"	C720MS	K31	C720MS																						

KIT NOTES: Installs Above Strut Assembly. K31. Part # C12CS Lifts Rear 1.25" if Needed.

<b>07-13 Tahoe / Yukon 1500 4WD KIT Front Struts 6-Lug with Replacement Rear Coils</b>																									
3.5-4"	C7361SK	K23	C7361A+C7361ST+C7361SR																						

KIT NOTES: K23. OEM Tires & Wheels can be Used.

<b>07-13 Tahoe / Yukon 1500 4WD KIT Front Strut Spacers 6-Lug with Replacement Rear Coils (Autoride)</b>																									
3.5"	C7361ARK	K23	C7361A+C7361AR+C7361SR																						

KIT NOTES: K23. OEM Tires & Wheels can be Used.

<b>07-13 Tahoe / Yukon 1500 4WD KIT Front Struts 6-Lug with Replacement Rear Coils</b>																									
6"	C7661SK	K23	C7661A+C7661ST+C7661SR																						

KIT NOTES: K23. OEM Tires & Wheels can be Used.

**00-06 TAHOE / YUKON 1500 4WD**

**NOTE: ALL SHOCKS MUST BE ORDERED SEPARATELY**

<b>00-06 Tahoe / Yukon 4WD (Torsion Bar Front End) Torsion Keys (Front Leveling Kit)</b>																									
2"	C101KE		C101KE																						

<b>00-06 Tahoe / Yukon 1500 4WD System 6-Lug with Replacement Rear Coils</b>																									
3"	C9331K	K16, K23	C9341+C933R																						

KIT NOTES: Does NOT Require Removal of the Front Upper Differential Housing Mount. K16. Autoride Models Order Part# C93AR. Factory Shocks will be Retained. K23. OEM Tires & Wheels can be Used.

(K) 'Single' or 'Dual' Steering Stabilizers can ONLY be Used with Skyjacker Suspension Lift.

<b>00-06 Tahoe / Yukon 1500 4WD System NOT Designed for Autoride Models</b>																									
6"	C9631K	K27	C9631A+C9631B			1	C50R																		

KIT NOTES: K27. Not Designed for Autoride Models.

(K) 'Single' or 'Dual' Steering Stabilizers can ONLY be Used with Skyjacker Suspension Lift.

<b>00-06 Tahoe / Yukon 2500 4WD KIT NOT Designed for Autoride Models</b>																									
6"	C9671K	K12	C9671A+C9671B																						

KIT NOTES: K12. CANNOT Re-Use OEM Wheels. REQUIRES 4.5" Back Spacing on Wheels.

(K) 'Single' or 'Dual' Steering Stabilizers can ONLY be Used with Skyjacker Suspension Lift.

**92-98 TAHOE / YUKON FULL-SIZE 4WD**

**NOTE: ALL SHOCKS MUST BE ORDERED SEPARATELY**

<b>97-98 Tahoe / Yukon Full-Size 4WD Kit With Rear Add-A-Leafs</b>																									
2-2.5"	C2567K	K1, K7	C2567																						

KIT NOTES: K1. Includes # FBL97 Front Brake Lines. K7. See Brake Lines Section.

<b>92-96 Tahoe / Yukon Full-Size 4WD Kit With Rear Add-A-Leafs</b>																									
2-2.5"	C256K		C256																						

<b>93-98 Tahoe / Yukon Full-Size 4WD Kit (2 Door Only) With Blocks &amp; U-Bolts</b>																									
4.5-6"	C4636K	K2, K3, K11, K26	C46+C466+C4636																						

KIT NOTES: K2. Includes Brake Line Brackets. K3. Driveline / Exhaust Modifications may be Necessary. K11. 98-99 4-Door Yukon & Tahoe Extends Strut Arms 2" (4.5-6" Kit - The Strut Arms MUST be Lengthened 2"). K26. On Canadian Made Vehicle & 98-99 Models Steering Modification will be Necessary.



LIFT	Quick Kit	KIT NOTES	Component Box <i>(Requires 1 of Each)</i>	Front Springs		Rear Springs		Add-A-Leafs	Steering Correction <i>(Order 1 Each)</i>	Steering Stabilizers						HYDRO Shocks		NITRO Shocks		BLACK MAX		M95 Shocks		Labor Hours		
				Qty	Part #	Qty	Part #			White		Black		Silver		White		Black		Silver						
	Reference							OEM	Single	Dual	OEM	Single	Dual	OEM	Single	Dual	Front	Rear	Front	Rear	Front	Rear	Front	Rear		
<b>92-98 Blazer (Torsion Bar Front End)</b>																										
2"	C101KE		C101KE															H7081	H8084	N8081	N8084	B8581	B8584	M9581	M9584	2
<b>93-98 Tahoe / Yukon Full-Size 4WD System (2 Door Only)</b>																										
<b>With Replacement Rear Springs</b>																										
4.5-6"	C4636KST	K2, K3, K11, K26	C46+C466+C4636S			2	CR16S											H7085	H7086	N8085	N8086	B8585	B8586	M9585	M9586	12
KIT NOTES: K2. Includes Brake Line Brackets. K3. Driveline / Exhaust Modifications may be Necessary. K11. 98-99 4-Door Yukon & Tahoe Extends Strut Arms 2" (4.5-6" Kit - The Strut Arms MUST be Lengthened 2"). K26. On Canadian Made Vehicle & 98-99 Models Steering Modification will be Necessary.																										
<b>92 Blazer / Yukon Full-Size 4WD Kit</b>																										
<b>With Blocks &amp; U-Bolts</b>																										
4.5-6"	C4626K	K2, K3, K26	C46+C466+C4626															H7085	H7086	N8085	N8086	B8585	B8586	M9585	M9586	12
KIT NOTES: K2. Includes Brake Line Brackets. K3. Driveline / Exhaust Modifications may be Necessary. K26. On Canadian Made Vehicle & 98-99 Models Steering Modification will be Necessary.																										
<b>92 Blazer / Yukon Full-Size 4WD System</b>																										
<b>With Replacement Rear Springs</b>																										
4.5-6"	C4626KST	K2, K3, K26	C46+C466+C4626S			2	CR16S											H7085	H7086	N8085	N8086	B8585	B8586	M9585	M9586	12
KIT NOTES: K2. Includes Brake Line Brackets. K3. Driveline / Exhaust Modifications may be Necessary. K26. On Canadian Made Vehicle & 98-99 Models Steering Modification will be Necessary.																										
<b>67-91 BLAZER / JIMMY FULL-SIZE 4WD</b>																										
<b>NOTE: ALL SHOCKS MUST BE ORDERED SEPARATELY</b>																										
<b>88-91 Blazer / Jimmy Full-Size 4WD Kit</b>																										
<b>With Blocks &amp; U-Bolts &amp;/or Add-A-Leafs</b>																										
2.5"	C125AK8	K10	C125A8	2	C125S				CA50	7055	7220	8055	8220	9055	9220	H7051	H7053	N8051	N8053	B8551	B8553	M9551	M9553	4		
4"	C140AK8	K4, K6, K7, K10, K22	C140A8	2	C140S				CA100	7055	7220	8055	8220	9055	9220	H7051	H7053	N8051	N8053	B8551	B8553	M9551	M9553	4		
6"	C160AK8	K3, K4, K6, K7, K10, K22	C168A8	2	C160S				CA100	7055	7220	8055	8220	9055	9220	H7071	H7073	N8071	N8073	B8571	B8573	M9571	M9573	6		
8"	C180AK8	K3, K4, K6, K7, K10, K22	C168A8	2	C180S			R1120	CA50+CA100	7055	7220	8055	8220	9055	9220	H7071	H7073	N8071	N8073	B8571	B8573	M9571	M9573	7		
KIT NOTES: K3. Driveline / Exhaust Modifications may be Necessary. K4. Transfer Case Lowering Kit # TCL15 may be Needed. K6. Optional 4" Offset Drag Link Available - # GMDL4. K7. See Brake Lines Section. K10. Fitted Leafs are Available for Additional Weight Capacity (Heavy Winch Bumper, Big Block or Diesel Engine, Etc.). See Leaf Springs Section. K22. If Vehicle is Equipped with a Front Sway Bar, Lowering Brackets must be Ordered. See Chevrolet / GM Accessories.																										
<b>88-91 Blazer / Jimmy Full-Size 4WD System</b>																										
<b>With Replacement Rear Springs</b>																										
2.5"	C125AKS8	K10	C124AS8	2	C125S	2	CR12S		CA50	7055	7220	8055	8220	9055	9220	H7051	H7053	N8051	N8053	B8551	B8553	M9551	M9553	5		
4"	C140AKS8	K4, K6, K7, K10, K22	C124AS8	2	C140S	2	CR14S		CA100	7055	7220	8055	8220	9055	9220	H7051	H7053	N8051	N8053	B8551	B8553	M9551	M9553	5		
6"	C160AKS8	K3, K4, K6, K7, K10, K22	C168AS8	2	C160S	2	CR16S		CA100	7055	7220	8055	8220	9055	9220	H7071	H7073	N8071	N8073	B8571	B8573	M9571	M9573	6		
8"	C180AKS8	K3, K4, K6, K7, K10, K22	C168AS8	2	C180S	2	CR18S		CA50+CA100	7055	7220	8055	8220	9055	9220	H7071	H7073	N8071	N8073	B8571	B8573	M9571	M9573	7		
KIT NOTES: K3. Driveline / Exhaust Modifications may be Necessary. K4. Transfer Case Lowering Kit # TCL15 may be Needed. K6. Optional 4" Offset Drag Link Available - # GMDL4. K7. See Brake Lines Section. K10. Fitted Leafs are Available for Additional Weight Capacity (Heavy Winch Bumper, Big Block or Diesel Engine, Etc.). See Leaf Springs Section. K22. If Vehicle is Equipped with a Front Sway Bar, Lowering Brackets must be Ordered. See Chevrolet / GM Accessories.																										
<b>73-87 Blazer / Jimmy Full-Size 4WD Kit</b>																										
<b>With Blocks &amp; U-Bolts &amp;/or Add-A-Leafs</b>																										
2.5"	C125AK	K10	C125A	2	C125S				CA50	7055	7220	8055	8220	9055	9220	H7051	H7053	N8051	N8053	B8551	B8553	M9551	M9553	4		
4"	C140AK	K4, K6, K7, K10, K22	C140A	2	C140S				CA100	7055	7220	8055	8220	9055	9220	H7051	H7053	N8051	N8053	B8551	B8553	M9551	M9553	4		
6"	C160AK	K3, K4, K6, K7, K10, K22	C168A	2	C160S				CA100	7055	7220	8055	8220	9055	9220	H7071	H7073	N8071	N8073	B8571	B8573	M9571	M9573	6		
8"	C180AK	K3, K4, K6, K7, K10, K22	C168A	2	C180S			R1120	CA50+CA100	7055	7220	8055	8220	9055	9220	H7071	H7073	N8071	N8073	B8571	B8573	M9571	M9573	7		
KIT NOTES: K3. Driveline / Exhaust Modifications may be Necessary. K4. Transfer Case Lowering Kit # TCL15 may be Needed. K6. Optional 4" Offset Drag Link Available - # GMDL4. K7. See Brake Lines Section. K10. Fitted Leafs are Available for Additional Weight Capacity (Heavy Winch Bumper, Big Block or Diesel Engine, Etc.). See Leaf Springs Section. K22. If Vehicle is Equipped with a front Sway Bar, Lowering Brackets must be Ordered. See Chevrolet / GM Accessories.																										
<b>73-87 Blazer / Jimmy Full-Size 4WD System</b>																										
<b>With Replacement Rear Springs</b>																										
2.5"	C125AKS	K10	C124AS	2	C125S	2	CR12S		CA50	7055	7220	8055	8220	9055	9220	H7051	H7053	N8051	N8053	B8551	B8553	M9551	M9553	5		
4"	C140AKS	K4, K6, K7, K10, K22	C124AS	2	C140S	2	CR14S		CA100	7055	7220	8055	8220	9055	9220	H7051	H7053	N8051	N8053	B8551	B8553	M9551	M9553	5		
6"	C160AKS	K3, K4, K6, K7, K10, K22	C168AS	2	C160S	2	CR16S		CA100	7055	7220	8055	8220	9055	9220	H7071	H7073	N8071	N8073	B8571	B8573	M9571	M9573	6		
8"	C180AKS	K3, K4, K6, K7, K10, K22	C168AS	2	C180S	2	CR18S		CA50+CA100	7055	7220	8055	8220	9055	9220	H7071	H7073	N8071	N8073	B8571	B8573	M9571	M9573	7		
KIT NOTES: K3. Driveline / Exhaust Modifications may be Necessary. K4. Transfer Case Lowering Kit # TCL15 may be Needed. K6. Optional 4" Offset Drag Link Available - # GMDL4. K7. See Brake Lines Section. K10. Fitted Leafs are Available for Additional Weight Capacity (Heavy Winch Bumper, Big Block or Diesel Engine, Etc.). See Leaf Springs Section. K22. If Vehicle is Equipped with a Front Sway Bar, Lowering Brackets must be Ordered. See Chevrolet / GM Accessories.																										
<b>67-72 Blazer / Jimmy Full-Size 4WD Kit</b>																										
<b>With Blocks &amp; U-Bolts &amp;/or Add-A-Leafs</b>																										
2.5"	C225AK	K10	C225A	2	C225S				CA50	7055	7220	8055	8220	9055	9220	H7051	H7041	N8051	N8041	B8551	B8541	M9551	M9541	4		
4"	C240AK	K3, K5, K6, K7, K10, K22	C240A	2	C240S				CA100	7055	7220	8055	8220	9055	9220	H7051	H7041	N8051	N8041	B8551	B8541	M9551	M9541	4		
6"	C260AK	K3, K5, K6, K7, K10, K22	C268A	2	C260S				CA100	7055	7220	8055	8220	9055	9220	H7071	H7060	N8071	N8060	B8571	B8560	M9571	M9560	6		
8"	C280AK	K3, K5, K6, K7, K10, K22	C268A	2	C280S			R1120	CA50+CA100	7055	7220	8055	8220	9055	9220	H7071	H7060	N8071	N8060	B8571	B8560	M9571	M9560	7		
KIT NOTES: K3. Driveline / Exhaust Modifications may be Necessary. K5. Must have 3-Bolt Steering Knuckle. (If Your Vehicle has a 4 Bolt Closed Knuckle, Use GMDL4, Not CA100). K6. Optional 4" Offset Drag Link Available - # GMDL4. K7. See Brake Lines Section. K10. Fitted Leafs are Available for Additional Weight Capacity (Heavy Winch Bumper, Big Block or Diesel Engine, Etc.). See Leaf Springs Section. K22. If Vehicle is Equipped with a Front Sway Bar, Lowering Brackets must be Ordered. See Chevrolet / GM Accessories.																										



LIFT	Quick Kit	KIT NOTES	Component Box (Requires 1 of Each)	Front Springs		Rear Springs		Add-A-Leafs	Steering Correction (Order 1 Each)	Steering Stabilizers						HYDRO Shocks		NITRO Shocks		BLACK MAX		M95 Shocks		Labor Hours
				Qty	Part #	Qty	Part #			White		Black		Silver		White		Black		Silver				
	Reference		QTY	Part #	QTY	Part #	OEM	Single	Dual	OEM	Single	Dual	OEM	Single	Dual	Front	Rear	Front	Rear	Front	Rear	Front	Rear	

**88-91 SUBURBAN 4WD 6-LUG** **NOTE: ALL SHOCKS MUST BE ORDERED SEPARATELY**

88-91 Suburban 4WD Kit			6-Lug with Blocks & U-Bolts &/or Add-A-Leafs																					
2.5"	C125AK8	K10	C125A8	2	C125S				CA50	7055	7220	8055	8220	9055	9220	H7051	H7053	N8051	N8053	B8551	B8553	M9551	M9553	4
4"	C140AK8	K7, K10, K22	C140A8	2	C140S				CA50	7055	7220	8055	8220	9055	9220	H7051	H7053	N8051	N8053	B8551	B8553	M9551	M9553	4
6"	C160AK8	K3, K6, K7, K10, K22	C168A8	2	C160S				CA100	7055	7220	8055	8220	9055	9220	H7071	H7073	N8071	N8073	B8571	B8573	M9571	M9573	6
8"	C180AK8	K3, K4, K6, K7, K10, K22	C168A8	2	C180S			R225	CA50+CA100	7055	7220	8055	8220	9055	9220	H7071	H7073	N8071	N8073	B8571	B8573	M9571	M9573	7

KIT NOTES: K3. Driveline / Exhaust Modifications may be Necessary. K4. Transfer Case Lowering Kit # TCL15 may be Needed. K6. Optional 4" Offset Drag Link Available - # GMDL4. K7. See Brake Lines Section. K10. Fitted Leafs are Available for Additional Weight Capacity (Heavy Winch Bumper, Big Block or Diesel Engine, Etc.). See Leaf Springs Section. K22. If Vehicle is Equipped with a Front Sway Bar, Lowering Brackets must be Ordered. See Chevrolet / GM Accessories.

**88-91 Suburban 4WD System** **NOTE: ALL SHOCKS MUST BE ORDERED SEPARATELY**

88-91 Suburban 4WD System			6-Lug with 52" Replacement Rear Springs																					
2.5"	C125AKSS8	K10	C124AS8	2	C125S	2	CR14S		CA50	7055	7220	8055	8220	9055	9220	H7051	H7053	N8051	N8053	B8551	B8553	M9551	M9553	5
4"	C140AKSS8	K7, K10, K22	C124AS8	2	C140S	2	CR16S		CA50	7055	7220	8055	8220	9055	9220	H7051	H7053	N8051	N8053	B8551	B8553	M9551	M9553	5
6"	C160AKSS8	K3, K6, K7, K10, K22	C168AS8	2	C160S	2	CR18S		CA100	7055	7220	8055	8220	9055	9220	H7071	H7073	N8071	N8073	B8571	B8573	M9571	M9573	6
8"	C180AKSS8	K3, K4, K6, K7, K9, K10, K22	C180ASD8	2	C180S	2	CR18S		CA50+CA100	7055	7220	8055	8220	9055	9220	H7071	H7073	N8071	N8073	B8571	B8573	M9571	M9573	7

KIT NOTES: K3. Driveline / Exhaust Modifications may be Necessary. K4. Transfer Case Lowering Kit # TCL15 may be Needed. K6. Optional 4" Offset Drag Link Available - # GMDL4. K7. See Brake Lines Section. K9. This Lift also Includes 2" Blocks. K10. Fitted Leafs are Available for Additional Weight Capacity (Heavy Winch Bumper, Big Block or Diesel Engine, Etc.). See Leaf Springs Section. K22. If Vehicle is Equipped with a Front Sway Bar, Lowering Brackets must be Ordered. See Chevrolet / GM Accessories.

**88-91 Suburban 4WD System** **NOTE: ALL SHOCKS MUST BE ORDERED SEPARATELY**

88-91 Suburban 4WD System			6-Lug with 56" Replacement Rear Springs																					
4"	C140AKSD8	K7, K10, K22	C124AS8	2	C140S	2	CR24S		CA50	7055	7220	8055	8220	9055	9220	H7051	H7053	N8051	N8053	B8551	B8553	M9551	M9553	5
6"	C160AKSD8	K3, K6, K7, K10, K22	C168AS8	2	C160S	2	CR26S		CA100	7055	7220	8055	8220	9055	9220	H7071	H7073	N8071	N8073	B8571	B8573	M9571	M9573	6
8"	C180AKSD8	K3, K4, K6, K7, K9, K10, K22	C180ASD8	2	C180S	2	CR26S		CA50+CA100	7055	7220	8055	8220	9055	9220	H7071	H7073	N8071	N8073	B8571	B8573	M9571	M9573	7

KIT NOTES: K3. Driveline / Exhaust Modifications may be Necessary. K4. Transfer Case Lowering Kit # TCL15 may be Needed. K6. Optional 4" Offset Drag Link Available - # GMDL4. K7. See Brake Lines Section. K9. This Lift also Includes 2" Blocks. K10. Fitted Leafs are Available for Additional Weight Capacity (Heavy Winch Bumper, Big Block or Diesel Engine, Etc.). See Leaf Springs Section. K22. If Vehicle is Equipped with a front Sway Bar, Lowering Brackets must be Ordered. See Chevrolet / GM Accessories.

**88-91 Suburban 4WD Kit** **NOTE: ALL SHOCKS MUST BE ORDERED SEPARATELY**

88-91 Suburban 4WD Kit			8-Lug with Blocks & U-Bolts &/or Add-A-Leafs																					
2.5"	C125BK8	K10	C125B8	2	C125S				CA50	7055	7220	8055	8220	9055	9220	H7051	H7053	N8051	N8053	B8551	B8553	M9551	M9553	4
4"	C140BK8	K7, K10, K22	C140B8	2	C140S				CA50	7055	7220	8055	8220	9055	9220	H7051	H7053	N8051	N8053	B8551	B8553	M9551	M9553	4
6"	C160BK8	K3, K6, K7, K10, K22	C168B8	2	C160S				CA100	7055	7220	8055	8220	9055	9220	H7071	H7073	N8071	N8073	B8571	B8573	M9571	M9573	6
8"	C180BK8	K3, K4, K6, K7, K10, K22	C168B8	2	C180S			R225	CA50+CA100	7055	7220	8055	8220	9055	9220	H7071	H7073	N8071	N8073	B8571	B8573	M9571	M9573	7

KIT NOTES: K3. Driveline / Exhaust Modifications may be Necessary. K4. Transfer Case Lowering Kit # TCL15 may be Needed. K5. Must have 3-Bolt Steering Knuckle. (If Your Vehicle has a 4 Bolt Closed Knuckle, Use GMDL4, Not CA100) K6. Optional 4" Offset Drag Link Available - # GMDL4. K7. See Brake Lines Section. K10. Fitted Leafs are Available for Additional Weight Capacity (Heavy Winch Bumper, Big Block or Diesel Engine, Etc.). See Leaf Springs Section. K22. If Vehicle is Equipped with a Front Sway Bar, Lowering Brackets must be Ordered. See Chevrolet / GM Accessories.

**88-91 Suburban 4WD System** **NOTE: ALL SHOCKS MUST BE ORDERED SEPARATELY**

88-91 Suburban 4WD System			8-Lug with 56-Inch Replacement Rear Springs																					
4"	C140BKSD8	K7, K10, K22	C124BS8	2	C140S	2	CR24S		CA50	7055	7220	8055	8022	9055	9022	H7071	H7073	N8071	N8073	B8571	B8573	M9571	M9573	5
6"	C160BKSD8	K3, K6, K7, K10, K22	C168BS8	2	C160S	2	CR26S		CA100	7055	7220	8055	8022	9055	9022	H7071	H7073	N8071	N8073	B8571	B8573	M9571	M9573	6
8"	C180BKSD8	K3, K4, K6, K7, K9, K10, K22	C180BSD8	2	C180S	2	CR26S		CA50+CA100	7055	7220	8055	8220	9055	9220	H7071	H7073	N8071	N8073	B8571	B8573	M9571	M9573	7

KIT NOTES: K3. Driveline / Exhaust Modifications may be Necessary. K4. Transfer Case Lowering Kit # TCL15 may be Needed. K5. Must have 3-Bolt Steering Knuckle. (If Your Vehicle has a 4 Bolt Closed Knuckle, Use GMDL4, Not CA100) K6. Optional 4" Offset Drag Link Available - # GMDL4. K7. See Brake Lines Section. K9. This Lift also Includes 2" Blocks. K10. Fitted Leafs are Available for Additional Weight Capacity (Heavy Winch Bumper, Big Block or Diesel Engine, Etc.). See Leaf Springs Section. K22. If Vehicle is Equipped with a Front Sway Bar, Lowering Brackets must be Ordered. See Chevrolet / GM Accessories.

**73-87 SUBURBAN 4WD 6-LUG** **NOTE: ALL SHOCKS MUST BE ORDERED SEPARATELY**

73-87 Suburban 4WD Kit			6-Lug with Blocks & U-Bolts &/or Add-A-Leafs																					
2.5"	C125AK	K10	C125A	2	C125S				CA50	7055	7220	8055	8220	9055	9220	H7051	H7053	N8051	N8053	B8551	B8553	M9551	M9553	4
4"	C140AK	K7, K10, K22	C140A	2	C140S				CA50	7055	7220	8055	8220	9055	9220	H7051	H7053	N8051	N8053	B8551	B8553	M9551	M9553	4
6"	C160AK	K3, K6, K7, K10, K22	C168A	2	C160S				CA100	7055	7220	8055	8220	9055	9220	H7071	H7073	N8071	N8073	B8571	B8573	M9571	M9573	6
8"	C180AK	K3, K4, K6, K7, K10, K22	C168A	2	C180S			R225	CA50+CA100	7055	7220	8055	8220	9055	9220	H7071	H7073	N8071	N8073	B8571	B8573	M9571	M9573	7

KIT NOTES: K3. Driveline / Exhaust Modifications may be Necessary. K4. Transfer Case Lowering Kit # TCL15 may be Needed. K6. Optional 4" Offset Drag Link Available - # GMDL4. K7. See Brake Lines Section. K10. Fitted Leafs are Available for Additional Weight Capacity (Heavy Winch Bumper, Big Block or Diesel Engine, Etc.). See Leaf Springs Section. K22. If Vehicle is Equipped with a Front Sway Bar, Lowering Brackets must be Ordered. See Chevrolet / GM Accessories.

**73-87 Suburban 4WD System** **NOTE: ALL SHOCKS MUST BE ORDERED SEPARATELY**

73-87 Suburban 4WD System			6-Lug with 52" Replacement Rear Springs																					
2.5"	C125AKSS	K10	C124AS	2	C125S	2	CR14S		CA50	7055	7220	8055	8220	9055	9220	H7051	H7053	N8051	N8053	B8551	B8553	M9551	M9553	6
4"	C140AKSS	K7, K10, K22	C124AS	2	C140S	2	CR16S		CA50	7055	7220	8055	8220	9055	9220	H7051	H7053	N8051	N8053	B8551	B8553	M9551	M9553	6
6"	C160AKSS	K3, K6, K7, K10, K22	C168AS	2	C160S	2	CR18S		CA100	7055	7220	8055	8220	9055	9220	H7071	H7073	N8071	N8073	B8571	B8573	M9571	M9573	7

KIT NOTES: K3. Driveline / Exhaust Modifications may be Necessary. K6. Optional 4" Offset Drag Link Available - # GMDL4. K7. See Brake Lines Section. K10. Fitted Leafs are Available for Additional Weight Capacity (Heavy Winch Bumper, Big Block or Diesel Engine, Etc.). See Leaf Springs Section. K22. If Vehicle is Equipped with a Front Sway Bar, Lowering Brackets must be Ordered. See Chevrolet / GM Accessories.

LIFT	Quick Kit	KIT NOTES	Component Box <i>(Requires 1 of Each)</i>	Front Springs		Rear Springs		Add-A-Leafs	Steering Correction <i>(Order 1 Each)</i>	Steering Stabilizers						HYDRO Shocks		NITRO Shocks		BLACK MAX		M95 Shocks		Labor Hours
				Qty	Part #	Qty	Part #			White		Black		Silver		White		White		Black		Silver		
	Reference							OEM	Single	Dual	OEM	Single	Dual	OEM	Single	Dual	Front	Rear	Front	Rear	Front	Rear	Front	Rear
<b>73-87 Suburban 4WD System</b>			<b>6-Lug with 56" Replacement Rear Springs</b>																					
4"	C140AKSD	K10, K22	C124AS	2	C140S	2	CR24S		CA50	7055	7220	8055	8220	9055	9220	H7051	H7053	N8051	N8053	B8551	B8553	M9551	M9553	6
6"	C160AKSD	K3, K6, K7, K10, K22	C168AS	2	C160S	2	CR26S		CA100	7055	7220	8055	8220	9055	9220	H7071	H7073	N8071	N8073	B8571	B8573	M9571	M9573	7
8"	C180AKSD	K3, K4, K6, K7, K9, K10, K22	C180ASD	2	C180S	2	CR26S		CA50+CA100	7055	7220	8055	8220	9055	9220	H7071	H7073	N8071	N8073	B8571	B8573	M9571	M9573	7

KIT NOTES: K3. Driveline / Exhaust Modifications may be Necessary. K4. Transfer Case Lowering Kit # TCL15 may be Needed.  
 K6. Optional 4" Offset Drag Link Available - # GMDL4. K9. This Lift also Includes 2" Blocks. K7. See Brake Lines Section. K10. Fitted Leafs are Available for Additional Weight Capacity (Heavy Winch Bumper, Big Block or Diesel Engine, Etc.). See Leaf Springs Section. K22. If Vehicle is Equipped with a Front Sway Bar. Lowering Brackets must be Ordered. See Chevrolet / GM Accessories.

**73-87 SUBURBAN 4WD** **NOTE: ALL SHOCKS MUST BE ORDERED SEPARATELY**

<b>73-87 Suburban 4WD Kit</b>			<b>8-Lug with Blocks &amp; U-Bolts &amp;/or Add-A-Leafs</b>																					
2.5"	C125BK	K10	C125B	2	C125S				CA50	7055	7220	8055	8220	9055	9220	H7051	H7053	N8051	N8053	B8551	B8553	M9551	M9553	4
4"	C140BK	K7, K10, K22	C140B	2	C140S				CA50	7055	7220	8055	8220	9055	9220	H7051	H7053	N8051	N8053	B8551	B8553	M9551	M9553	4
6"	C160BK	K3, K6, K7, K10, K22	C168B	2	C160S				CA100	7055	7220	8055	8220	9055	9220	H7071	H7073	N8071	N8073	B8571	B8573	M9571	M9573	6
8"	C180BK	K3, K4, K6, K7, K10, K22	C168B	2	C180S		R225		CA50+CA100	7055	7220	8055	8220	9055	9220	H7071	H7073	N8071	N8073	B8571	B8573	M9571	M9573	7

KIT NOTES: K3. Driveline / Exhaust Modifications may be Necessary. K4. Transfer Case Lowering Kit # TCL15 may be Needed.  
 K5. Must have 3-Bolt Steering Knuckle. (If Your Vehicle has a 4 Bolt Closed Knuckle, Use GMDL4, Not CA100) K6. Optional 4" Offset Drag Link Available - # GMDL4.  
 K7. See Brake Lines Section. K10. Fitted Leafs are Available for Additional Weight Capacity (Heavy Winch Bumper, Big Block or Diesel Engine, Etc.). See Leaf Springs Section. K22. If Vehicle is Equipped with a Front Sway Bar, Lowering Brackets must be Ordered. See Chevrolet / GM Accessories.

**73-87 Suburban 4WD System** **NOTE: ALL SHOCKS MUST BE ORDERED SEPARATELY**

<b>73-87 Suburban 4WD System</b>			<b>8-Lug with 56" Replacement Rear Springs</b>																					
4"	C140BKSD	K7, K10, K22	C124BS	2	C140S	2	CR24S		CA50	7055	7220	8055	8220	9055	9220	H7051	H7053	N8051	N8053	B8551	B8553	M9551	M9553	6
6"	C160BKSD	K3, K6, K7, K10, K22	C168BS	2	C160S	2	CR26S		CA100	7055	7220	8055	8220	9055	9220	H7071	H7073	N8071	N8073	B8571	B8573	M9571	M9573	7
8"	C180BKSD	K3, K4, K6, K7, K9, K10, K22	C180BSD	2	C180S	2	CR26S		CA50+CA100	7055	7220	8055	8220	9055	9220	H7071	H7073	N8071	N8073	B8571	B8573	M9571	M9573	7

KIT NOTES: K3. Driveline / Exhaust Modifications may be Necessary. K4. Transfer Case Lowering Kit # TCL15 may be Needed.  
 K5. Must have 3-Bolt Steering Knuckle. (If Your Vehicle has a 4 Bolt Closed Knuckle, Use GMDL4, Not CA100) K6. Optional 4" Offset Drag Link Available - # GMDL4.  
 K7. See Brake Lines Section. K9. This Lift also Includes 2" Blocks. K10. Fitted Leafs are Available for Additional Weight Capacity (Heavy Winch Bumper, Big Block or Diesel Engine, Etc.). See Leaf Springs Section. K22. If Vehicle is Equipped with a Front Sway Bar. Lowering Brackets must be Ordered. See Chevrolet / GM Accessories.

**67-72 SUBURBAN 4WD** **NOTE: ALL SHOCKS MUST BE ORDERED SEPARATELY**

<b>67-72 Suburban 4WD Kit</b>			<b>With Blocks &amp; U-Bolts &amp;/or Add-A-Leafs</b>																					
2.5"	C225AK	K10	C225A	2	C225S				CA50	7055	7220	8055	8220	9055	9220	H7051	H7041	N8051	N8041	B8551	B8541	M9551	M9541	4
4"	C240AK	K7, K10, K22	C240A	2	C240S				CA50	7055	7220	8055	8220	9055	9220	H7051	H7041	N8051	N8041	B8551	B8541	M9551	M9541	4
6"	C260AK	K5, K6, K7, K22	C268A	2	C260S				CA100	7055	7220	8055	8220	9055	9220	H7071	H7060	N8071	N8060	B8571	B8560	M9571	M9560	6
8"	C280AK	K3, K5, K6, K7, K22	C268A	2	C280S		R225		CA50+CA100	7055	7220	8055	8220	9055	9220	H7071	H7060	N8071	N8060	B8571	B8560	M9571	M9560	7

KIT NOTES: K3. Driveline / Exhaust Modifications may be Necessary. K5. Must have 3-Bolt Steering Knuckle. (If Your Vehicle has a 4 Bolt Closed Knuckle, Use GMDL4, Not CA100). K6. Optional 4" Offset Drag Link Available - # GMDL4. K7. See Brake Lines Section. K22. If Vehicle is Equipped with a Front Sway Bar, Lowering Brackets must be Ordered. See Chevrolet / GM Accessories.

**69-72 Suburban 4WD System** **NOTE: ALL SHOCKS MUST BE ORDERED SEPARATELY**

<b>69-72 Suburban 4WD System</b>			<b>With 52" Replacement Rear Springs</b>																					
2.5"	C225AKSS	K10	C224AS	2	C225S	2	CR14S		CA50	7055	7220	8055	8220	9055	9220	H7051	H7041	N8051	N8041	B8551	B8541	M9551	M9541	6
4"	C240AKSS	K7, K10, K22	C224AS	2	C240S	2	CR16S		CA50	7055	7220	8055	8220	9055	9220	H7051	H7041	N8051	N8041	B8551	B8541	M9551	M9541	6
6"	C260AKSS	K5, K6, K7, K10, K22	C268AS	2	C260S	2	CR18S		CA100	7055	7220	8055	8220	9055	9220	H7071	H7060	N8071	N8060	B8571	B8560	M9571	M9560	7
8"	C280AKSS	K3, K5, K6, K7, K9, K10, K22	C280ASD	2	C280S	2	CR18S		CA50+CA100	7055	7220	8055	8220	9055	9220	H7071	H7060	N8071	N8060	B8571	B8560	M9571	M9560	7

KIT NOTES: K3. Driveline / Exhaust Modifications may be Necessary. K5. Must have 3-Bolt Steering Knuckle. K6. Optional 4" Offset Drag Link Available - # GMDL4.  
 K7. See Brake Lines Section. K9. This Lift also Includes 2" Blocks. K10. Fitted Leafs are Available for Additional Weight Capacity (Heavy Winch Bumper, Big Block or Diesel Engine, Etc.). See Leaf Springs Section. K22. If Vehicle is Equipped with a Front Sway Bar, Lowering Brackets must be Ordered. See Chevrolet / GM Accessories.

**69-72 Suburban 4WD System** **NOTE: ALL SHOCKS MUST BE ORDERED SEPARATELY**

<b>69-72 Suburban 4WD System</b>			<b>With 56" Replacement Rear Springs</b>																					
4"	C240AKSD	K7, K10, K22	C224AS	2	C240S	2	CR24S		CA50	7055	7220	8055	8220	9055	9220	H7051	H7041	N8051	N8041	B8551	B8541	M9551	M9541	6
6"	C260AKSD	K5, K6, K7, K10, K22	C268AS	2	C260S	2	CR26S		CA100	7055	7220	8055	8220	9055	9220	H7071	H7060	N8071	N8060	B8571	B8560	M9571	M9560	7
8"	C280AKSD	K3, K5, K6, K7, K9, K10, K22	C280ASD	2	C280S	2	CR26S		CA50+CA100	7055	7220	8055	8220	9055	9220	H7071	H7060	N8071	N8060	B8571	B8560	M9571	M9560	7

KIT NOTES: K3. Driveline / Exhaust Modifications may be Necessary. K5. Must have 3-Bolt Steering Knuckle. K6. Optional 4" Offset Drag Link Available - # GMDL4.  
 K7. See Brake Lines Section. K9. This Lift also Includes 2" Blocks. K10. Fitted Leafs are Available for Additional Weight Capacity (Heavy Winch Bumper, Big Block or Diesel Engine, Etc.). See Leaf Springs Section. K22. If Vehicle is Equipped with a Front Sway Bar, Lowering Brackets must be Ordered. See Chevrolet / GM Accessories.



LIFT	Quick Kit Reference	KIT NOTES	Component Box		Front Springs		Rear Springs		Add-A-Leafs	Steering Correction (Order 1 Each)	Steering Stabilizers						HYDRO Shocks		NITRO Shocks		BLACK MAX		M95 Shocks		Labor Hours			
			(Requires 1 of Each)		Qty	Part #	Qty	Part #			White		Black		Silver		White		White		Black		Silver					
			OEM	Single	Dual	OEM	Single	Dual			OEM	Single	Dual	OEM	Single	Dual	Front	Rear	Front	Rear	Front	Rear	Front	Rear		Front	Rear	
<b>STANDARD SERIES</b>																												
<b>00-01 1500 Ram Pickup 4WD Kit</b>		<b>Class I with Add-A-Leafs</b>																										
2"	D201K				1	D20			R222		7007		7218	8007		8218	9007		9218	H7092	H7017	N8092	N8017	B8592	B8517	M9592	M9517	4
3"	D3012K	W8		D3012	1	D30			Included		7007		7218	8007		8218	9007		9218	H7092	H7017	N8092	N8017	B8592	B8517	M9592	M9517	6
5"	D5012K	W8, W19		D4552 + D501	1	D50			Included	Included	Included		7218	8007		8218	9007		9218	H7093	H7017	N8093	N8017	B8593	B8517	M9593	M9517	9
KIT NOTES: W8. 00-01 Models Equipped with Factory 'OFF-ROAD Package' will Receive 1" Less Lift. W19. All Wheel Drive Models may Experience a Front Driveline Vibration. If so, Order Index Ring Part # IXR20, Seal Adapter Part # DTSA10 & Seal Part # TCS2675.																												
<b>00-01 1500 Ram Pickup 4WD System</b>		<b>Class I with Replacement Rear Springs</b>																										
5"	D5012KS	W8, W19, W30		D4552 + D501S	1	D50	2	DR54S		Included	Included		7218	8007		8218	9007		9218	H7093	H7017	N8093	N8017	B8593	B8517	M9593	M9517	9
KIT NOTES: W8. 00-01 Models Equipped with Factory 'OFF-ROAD Package' will Receive 1" Less Lift. W19. All Wheel Drive Models may Experience a Front Driveline Vibration. If so, Order Index Ring Part # IXR20, Seal Adapter Part # DTSA10 & Seal Part # TCS2675. W30. Brake Line Brackets Included.																												
<b>00-01 1500 Ram Pickup 4WD Kit</b>		<b>Class II with Add-A-Leafs</b>																										
5"	D5022K	W6, W8, W19, W30		D4552 + D502	1	D50			Included	Included	Included		7218	8007		8218	9007		9218	H7093	H7017	N8093	N8017	B8593	B8517	M9593	M9517	10
KIT NOTES: W6. Class II Includes Front Dual Shock Brackets, Upper Links & Lower Link Skid Plates. W8. 00-01 Models Equipped with Factory 'OFF-ROAD Package' will Receive 1" Less Lift. W19. All Wheel Drive Models may Experience a Front Driveline Vibration. If so, Order Index Ring Part # IXR20, Seal Adapter Part # DTSA10 & Seal Part # TCS2675. W30. Brake Line Brackets Included. Must Order 2 of each Front Shock and 2 Rear Shocks.																												
<b>00-01 1500 Ram Pickup 4WD System</b>		<b>Class II with Replacement Rear Springs</b>																										
5"	D5022KS	W6 W8, W19, W30		D4552 + D502S	1	D50	2	DR54S		Included	Included		7218	8007		8218	9007		9218	H7093	H7017	N8093	N8017	B8593	B8517	M9593	M9517	10
KIT NOTES: W6. Class II Includes Front Dual Shock Brackets, Upper Links & Lower Link Skid Plates. W8. 00-01 Models Equipped with Factory 'OFF-ROAD Package' will Receive 1" Less Lift. W19. All Wheel Drive Models may Experience a Front Driveline Vibration. If so, Order Index Ring Part # IXR20, Seal Adapter Part # DTSA10, & Seal Part # TCS2675. W30. Brake Line Brackets Included. Must Order 2 of each Front Shock and 2 Rear Shocks.																												
<b>00-01 1500 RAM 4WD EQUIPPED WITH V8 ENGINE &amp; 2.5" WIDE REAR SPRINGS</b>											<b>NOTE: ALL SHOCKS MUST BE ORDERED SEPARATELY</b>																	
<b>LONG ARM SERIES</b>																												
<b>00-01 1500 Ram Pickup 4WD Kit</b>		<b>With Blocks &amp; U-Bolts &amp; Add-A-Leafs</b>																										
7"	D702K-DX	W6, W25, W26		D7075-DX + D702	1	D70			Included	DA602	Included		7218	8007		8218	9007		9218	H7038	H7078	N8038	N8078	B8538	B8578	M9538	M9578	12
KIT NOTES: W6. Class II Includes Front Dual Shock Brackets, Upper Links & Lower Link Skid Plates. W25. Seal Adapter Part # DTSA10 & Seal Part # TCS2675 are Included. W26. 6 Speed Models will Require Modifications to Transmission Bracket. Must Order 2 of each Front Shock and 2 Rear Shocks.																												
<b>00-01 1500 Ram Pickup 4WD System</b>		<b>With Replacement Rear Springs</b>																										
7"	D702KS-DX	W6, W25, W26		D7075-DX + D702S	1	D70	2	DR56S		DA602	Included		7218	8007		8218	9007		9218	H7038	H7078	N8038	N8078	B8538	B8578	M9538	M9578	12
KIT NOTES: W6. Class II Includes Front Dual Shock Brackets, Upper Links & Lower Link Skid Plates. W25. Seal Adapter Part # DTSA10 & Seal Part # TCS2675 are Included. W26. 6 Speed Models will Require Modifications to Transmission Bracket. Must Order 2 of each Front Shock and 2 Rear Shocks.																												
<b>94-99 1500 RAM 4WD EQUIPPED WITH V8 ENGINE AND 2.5" WIDE REAR SPRINGS</b>											<b>NOTE: ALL SHOCKS MUST BE ORDERED SEPARATELY</b>																	
<b>VALUE KITS</b>																												
<b>94-99 1500 Ram Pickup 4WD Kit</b>		<b>Metal Spacers with Rear Add-A-Leafs</b>																										
2.5"	D20MK			D25MS					R222		7007			8007			9007			H7092	H7017	N8092	N8017	B8592	B8517	M9592	M9517	4
<b>94-99 1500 Ram Pickup 4WD Kit</b>		<b>Polyurethane Spacers with Rear Add-A-Leafs</b>																										
2"	D20PK			D20P					R222		7007			8007			9007			H7092	H7017	N8092	N8017	B8592	B8517	M9592	M9517	4
<b>94-18 DODGE RAM 1500 2WD</b>																												
<b>94-18 Dodge Ram 1500 2WD</b>		<b>Leveling Spacer Kit</b>																										
2"	D220MS	W2		D220MS																----	----	----	----	----	----	----	----	2
KIT NOTES: W2. Will NOT fit Air Ride.																												
<b>STANDARD SERIES</b>																												
<b>94-99 1500 Ram Pickup 4WD Kit</b>		<b>Class I with Add-A-Leafs</b>																										
2"	D201K				1	D20			R222		7007		(W13)	8007		(W17)	9007		(W29)	H7092	H7017	N8092	N8017	B8592	B8517	M9592	M9517	4
3"	D301K			D301	1	D30			Included		7007		(W13)	8007		(W17)	9007		(W29)	H7092	H7017	N8092	N8017	B8592	B8517	M9592	M9517	6
5"	D501K	W1, W30		D4550 + D501	1	D50			Included	Included	Included		(W13)	8007		(W17)	9007		(W29)	H7093	H7017	N8093	N8017	B8593	B8517	M9593	M9517	9
KIT NOTES: W11. 5 & 7" Lift Kits are Designed to Only Fit Models Manufactured ON or AFTER February 9, 1994 Due to Size of Track Bar Stud. W30. Brake Line Brackets Included. W13. On 94-97 Models Use # 7217 Steering Stabilizer. On 98-99 Models with 3" Axle Tube Use # 7218. On 98-99 Models with 3.75" Axle Tube Use # 7270. W17. On 94-97 Models Use # 8217 Steering Stabilizer. On 98-99 Models with 3" Axle Tube Use # 8218. On 98-99 Models with 3.75" Axle Tube Use # 8270. W29. On 94-97 Models Use # 9217 Steering Stabilizer. On 98-99 Models with 3" Axle Tube Use # 9218. On 98-99 Models with 3.75" Axle Tube Use # 9270.																												
<b>94-99 1500 Ram Pickup 4WD System</b>		<b>Class I with Replacement Rear Springs</b>																										
3"	D301KS	W10		D301S	1	D30	2	DR56S			7007		(W13)	8007		(W17)	9007		(W29)	H7092	H7017	N8092	N8017	B8592	B8517	M9592	M9517	6
5"	D501KS	W11, W30		D4550 + D501S	1	D50	2	DR54S		Included	Included		(W13)	8007		(W17)	9007		(W29)	H7093	H7017	N8093	N8017	B8593	B8517	M9593	M9517	9
KIT NOTES: W10. The Factory Block is Removed. W11. 5 & 7" Lift Kits are Designed to Only Fit Models Manufactured ON or AFTER February 9, 1994 Due to Size of Track Bar Stud. W30. Brake Line Brackets Included. W13. On 94-97 Models Use # 7217 Steering Stabilizer. On 98-99 Models with 3" Axle Tube Use # 7218. For 98-99 Models with 3.75" Axle Tube Use # 7270. W17. On 94-97 Models Use # 8217 Steering Stabilizer. On 98-99 Models with 3" Axle Tube Use # 8218. For 98-99 Models with 3.75" Axle Tube Use # 8270. W29. On 94-97 Models Use # 9217 Steering Stabilizer. On 98-99 Models with 3" Axle Tube Use # 9218. For 98-99 Models with 3.75" Axle Tube Use # 9270.																												

DODGE / RAM

DODGE / RAM

LIFT	Quick Kit Reference	KIT NOTES	Component Box		Front Springs		Rear Springs		Add-A-Leafs	Steering Correction (Order 1 Each)	Steering Stabilizers						HYDRO Shocks		NITRO Shocks		BLACK MAX		M95 Shocks		Labor Hours		
			(Requires 1 of Each)	Qty	Part #	Qty	Part #	White			Black			Silver			White		White		Black		Silver				
								OEM			Single	Dual	OEM	Single	Dual	OEM	Single	Dual	Front	Rear	Front	Rear	Front	Rear		Front	Rear
<b>94-99 1500 Ram Pickup 4WD Kit Class II with Add-A-Leafs</b>																											
5"	D502K	W6, W11, W30	D4550 + D502	1	D50				Included	Included	Included	(W13)	8007	(W13)	9007	(W13)	H7093 H7017 H7058	N8093 N8017 N8058	B8593 B8517 B8558	M9593 M9517 M9558							10
KIT NOTES: W6. Class II Includes Front Dual Shock Brackets, Upper Links & Lower Link Skid Plates. W11. 5 & 7" Lift Kits are Designed to Only Fit Models Manufactured ON or AFTER February 9, 1994 Due to Size of Track Bar Stud. W30. Brake Line Brackets Included.											W13. See Steering Stabilizer Section for Year, Make, Model Fitment.											Must Order 2 of each Front Shock and 2 Rear Shocks.					
<b>94-99 1500 Ram Pickup 4WD System Class II with Replacement Rear Springs</b>																											
3"	D302KS	W6, W10	D302S	1	D30	2	DR56S						7007	(W13)	8007	(W13)	9007	(W13)	H7092 H7017 H7023	N8092 N8017 N8023	B8592 B8517 B8523	M9592 M9517 M9523					8
5"	D502KS	W6, W11, W30	D4550 + D502S	1	D50	2	DR54S			Included			Included	(W13)	8007	(W13)	9007	(W13)	H7093 H7017 H7058	N8093 N8017 N8058	B8593 B8517 B8558	M9593 M9517 M9558					10
KIT NOTES: W6. Class II Includes Front Dual Shock Brackets, Upper Links & Lower Link Skid Plates. W10. The Factory Block is Removed. W11. 5 & 7" Lift Kits are Designed to Only Fit Models Manufactured ON or AFTER February 9, 1994 Due to Size of Track Bar Stud. W30. Brake Line Brackets Included.											W13. See Steering Stabilizer Section for Year, Make, Model Fitment.											Must Order 2 of each Front Shock and 2 Rear Shocks.					
<b>94-99 1500 RAM 4WD EQUIPPED WITH V8 ENGINE &amp; 2.5" WIDE REAR SPRINGS LONG ARM SERIES</b>																											
<b>NOTE: ALL SHOCKS MUST BE ORDERED SEPARATELY</b>																											
<b>94-99 1500 Ram Pickup 4WD Kit With Blocks &amp; U-Bolts &amp; Add-A-Leafs</b>																											
7"	D702K-DX	W6, W11, W25, W26	D7075-DX+D702	1	D70				Included	DA600			Included	(W13)	8007	(W13)	9007	(W13)	H7038 H7078 H7060	N8038 N8078 N8060	B8538 B8578 B8560	M9538 M9578 M9560					12
KIT NOTES: W6. Class II Includes Front Dual Shock Brackets, Upper Links & Lower Link Skid Plates. W11. 5 & 7" Lift Kits are Designed to Only Fit Models Manufactured ON or AFTER February 9, 1994 Due to Size of Track Bar Stud. W25. Seal Adapter Part # DTSA10 & Seal Part # TCS2675 are Included. W26. 6 Speed Models will Require Modifications to Transmission Bracket.											W13. See Steering Stabilizer Section for Year, Make, Model Fitment.											Must Order 2 of each Front Shock and 2 Rear Shocks.					
<b>94-99 1500 Ram Pickup 4WD System With Replacement Rear Springs</b>																											
7"	D702KS-DX	W6, W11, W25, W26	D7075-DX+D702S	1	D70	2	DR56S			DA600			Included	(W13)	8007	(W13)	9007	(W13)	H7038 H7078 H7060	N8038 N8078 N8060	B8538 B8578 B8560	M9538 M9578 M9560					12
KIT NOTES: W6. Class II Includes Front Dual Shock Brackets, Upper Links & Lower Link Skid Plates. W11. 5 & 7" Lift Kits are Designed to Only Fit Models Manufactured ON or AFTER February 9, 1994 Due to Size of Track Bar Stud. W25. Seal Adapter Part # DTSA10 & Seal Part # TCS2675 are Included. W26. 6 Speed Models will Require Modifications to Transmission Bracket.											W13. See Steering Stabilizer Section for Year, Make, Model Fitment.											Must Order 2 of each Front Shock and 2 Rear Shocks.					
<b>74.5-93 W150 &amp; W250 4WD FULL-SIZE WITH GAS ENGINES</b>																											
<b>NOTE: ALL SHOCKS MUST BE ORDERED SEPARATELY</b>																											
<b>74.5-93 W150 &amp; W250 Pickup 4WD Full-Size Kit With Blocks &amp; U-Bolts &amp; or Add-A-Leafs</b>																											
2-2.5"	D200BK	W14, W30	D240B	2	D200S					DA20			7110	7220		8110	8220		9110	9220	H7027 H7038	N8027 N8038	B8527 B8538	M9527 M9538			5
4"	D400BK	W14, W15, W16	D240B	2	D400S					DA40			7110	7220		8110	8220		9110	9220	H7017 H7038	N8017 N8038	B8517 B8538	M9517 M9538			5
6"	D600BK	W14, W15, W16	D680B	2	D600S					DA60			7110	7220		8110	8220		9110	9220	H7017 H7068	N8017 N8068	B8517 B8568	M9517 M9568			6
8"	D800BK	W2, W5, W15, W16	D680B	2	D800S			R1120		DA40 + DA60			7110	7220		8110	8220		9110	9220	H7036 H7068	N8036 N8068	B8536 B8568	M9536 M9568			8
KIT NOTES: W2. Pitman Arm Fits 78-93 Models Only (74.5-77 Models Use Part # DA60 on 4" Lifts). Steering Correction (See Steering Components Section). W5. 74.5-77 Models MUST Use # DA65 & # DL10 for Steering Correction. W14. Adjustable Drag Link # DL10 Recommended to Replace Factory Non-Adjustable Link on 72-93 Models. W15. If Vehicle is Equipped with a Front Sway Bar. Lowering Brackets must be Ordered. See Dodge Accessories Section. W16. See Brake Lines Section.																											
<b>74.5-93 W150 &amp; W250 Pickup 4WD Full-Size Kit With Add-A-Leafs</b>																											
2.5"	D200BAK	W2, W14, W16	D240BA	2	D200S			R1120		DA20			7110	7220		8110	8220		9110	9220	H7027 H7038	N8027 N8038	B8527 B8538	M9527 M9538			5
4"	D400BAK	W1, W2, W14, W15, W16	D240BA	2	D400S			R225		DA40			7110	7220		8110	8220		9110	9220	H7017 H7038	N8017 N8038	B8517 B8538	M9517 M9538			5
KIT NOTES: W1. This Kit Uses Add-A-Leafs Instead of Block & U-Bolt Kit for the Rear. W2. Pitman Arm Fits 78-93 Models Only (74.5-77 Models Use DA60 on 4" Lifts). W14. Adjustable Drag Link # DL10 Recommended to Replace Factory Non-Adjustable Link on 72-93 Models. W15. If Vehicle is Equipped with a Front Sway Bar. Lowering Brackets must be Ordered. See Dodge Accessories Section. W16. See Brake Lines Section.																											
<b>74.5-93 W150 &amp; W250 Pickup 4WD Full-Size System With Replacement Rear Springs</b>																											
2.5"	D200BKS	W2, W14, W16	D240BS	2	D200S	2	DR40S			DA20			7110	7220		8110	8220		9110	9220	H7027 H7038	N8027 N8038	B8527 B8538	M9527 M9538			5
4"	D400BKS	W2, W10, W14, W15, W16	D240BS	2	D400S	2	DR60S			DA40			7110	7220		8110	8220		9110	9220	H7017 H7038	N8017 N8038	B8517 B8538	M9517 M9538			5
6"	D600BKS	W14, W15, W16	D680BS	2	D600S	2	DR40S			DA60			7110	7220		8110	8220		9110	9220	H7017 H7068	N8017 N8068	B8517 B8568	M9517 M9568			6
8"	D800BKS	W2, W5, W15, W16	D680BS	2	D800S	2	DR60S			DA40 + DA60			7110	7220		8110	8220		9110	9220	H7036 H7068	N8036 N8068	B8536 B8568	M9536 M9568			8
KIT NOTES: W2. Pitman Arm Fits 78-93 Models Only (74.5-77 Models Use Part # DA60 on 4" Lifts). Steering Correction (See Steering Components Section). W5. 74.5-77 Models MUST Use # DA65 & # DL10 for Steering Correction. W10. The Factory Block is Removed. W14. Adjustable Drag Link # DL10 Recommended to Replace Factory Non-Adjustable Link on 72-93 Models. W15. If Vehicle is Equipped with a Front Sway Bar. Lowering Brackets must be Ordered. See Dodge Accessories Section. W16. See Brake Lines Section.																											
<b>74.5-93 W350 PICKUP 4WD FULL-SIZE WITH GAS ENGINES</b>																											
<b>NOTE: ALL SHOCKS MUST BE ORDERED SEPARATELY</b>																											
<b>74.5-93 W350 Pickup 4WD Full-Size Kit With Blocks &amp; U-Bolts</b>																											
2.5"	D200CK	W2, W14, W16	D240CD	2	D200S					DA20			7110	7220		8110	8220		9110	9220	H7027 H7038	N8027 N8038	B8527 B8538	M9527 M9538			5
3-4"	D400CK	W2, W14, W15, W16	D240CD	2	D400S					DA40			7110	7220		8110	8220		9110	9220	H7017 H7038	N8017 N8038	B8517 B8538	M9517 M9538			5
5-6"	D600CK	W2, W14, W15, W16	D600CD	2	D600S					DA40 + SB60			7110	7220		8110	8220		9110	9220	H7017 H7068	N8017 N8068	B8517 B8568	M9517 M9568			6
KIT NOTES: W2. Pitman Arm Fits 78-93 Models Only (74.5-77 Models Use Part # DA60 on 4" Lifts). W14. Adjustable Drag Link # DL10 Recommended to Replace Factory Non-Adjustable Link on 72-93 Models. W15. If Vehicle is Equipped with a Front Sway Bar. Lowering Brackets must be Ordered. See Dodge Accessories Section. W16. See Brake Lines Section.																											

DODGE / RAM

DODGE / RAM

LIFT	Quick Kit Reference	KIT NOTES	Component Box (Requires 1 of Each)	Front Springs		Rear Springs		Add-A- Leafs	Steering Correction (Order 1 Each)	Steering Stabilizers						HYDRO Shocks		NITRO Shocks		BLACK MAX		M95 Shocks		Labor Hours				
				Qty	Part #	Qty	Part #			White		Black		Silver		White		Black		Silver								
				OEM	Single	Dual	OEM			Single	Dual	OEM	Single	Dual	OEM	Single	Dual	Front	Rear	Front	Rear	Front	Rear		Front	Rear		
<b>74.5-93 W350 Pickup 4WD Full-Size Kit With Blocks &amp; U-Bolts &amp;/or Add-A-Leafs</b>																												
1.5-2"	D200CAK	W1, W2, W14, W16	D240CDA	2	D200S			R1120	DA20			7110	7220		8110	8220		9110	9220	H7027	H7038	N8027	N8038	B8527	B8538	M9527	M9538	6
3-4"	D400CAK	W1, W2, W14, W15, W16	D240CDA	2	D400S			R225	DA40			7110	7220		8110	8220		9110	9220	H7017	H7038	N8017	N8038	B8517	B8538	M9517	M9538	6
7-8"	D800CK	W2, W15, W16	D600CD	2	D800S			R225	DA40 + SB60			7110	7220		8110	8220		9110	9220	H7036	H7068	N8036	N8068	B8536	B8568	M9536	M9568	8
KIT NOTES: W1. This Kit Uses Add-A-Leafs Instead of Block & U-Bolt Kit for the Rear. W2. Pitman Arm Fits 78-93 Models Only (74.5-77 Models Use Part # DA60 on 4" Lifts). W14. Adjustable Drag Link # DL10 Recommended to Replace Factory Non-Adjustable Link on 72-93 Models. W15. If Vehicle is Equipped with a Front Sway Bar. Lowering Brackets must be Ordered. See Dodge Accessories Section. W16. See Brake Lines Section.																												
<b>74.5-93 W350 Pickup 4WD Full-Size System With Replacement Rear Springs</b>																												
3-4"	D400CKS	W2, W10, W14, W15, W16	D240CS	2	D400S	2	DR60S		DA40			7110	7220		8110	8220		9110	9220	H7017	H7038	N8017	N8038	B8517	B8538	M9517	M9538	5
5-6"	D600CKS	W2, W14, W15, W16	D600CDS	2	D600S	2	DR40S		DA40 + SB60			7110	7220		8110	8220		9110	9220	H7017	H7068	N8017	N8068	B8517	B8568	M9517	M9568	6
7-8"	D800CKS	W2, W15, W16	D600CDS	2	D800S	2	DR60S		DA40 + SB60			7110	7220		8110	8220		9110	9220	H7036	H7068	N8036	N8068	B8536	B8568	M9536	M9568	8
KIT NOTES: W2. Pitman Arm Fits 78-93 Models Only (74.5-77 Models Use Part # DA60 on 4" Lifts). W10. The Factory Block is Removed. W14. Adjustable Drag Link # DL10 Recommended to Replace Factory Non-Adjustable Link on 72-93 Models. W15. If Vehicle is Equipped with a Front Sway Bar. Lowering Brackets must be Ordered. See Dodge Accessories Section. W16. See Brake Lines Section.																												
<b>61-74 W150 &amp; W250 4WD FULL-SIZE WITH GAS ENGINES NOTE: ALL SHOCKS MUST BE ORDERED SEPARATELY</b>																												
<b>61-74 W150 &amp; W250 Pickup 4WD Full-Size Kit With Blocks &amp; U-Bolts</b>																												
2.5"	D200AK		D240A	2	D200S							7110	7220		8110	8220		9110	9220	H7027	H7038	N8027	N8038	B8527	B8538	M9527	M9538	5
4"	D400AK	W7, W14, W15, W16	D240A	2	D400S				DA60			7110	7220		8110	8220		9110	9220	H7017	H7038	N8017	N8038	B8517	B8538	M9517	M9538	5
6"	D600AK	W7, W14, W15, W16	D680A	2	D600S				DA60			7110	7220		8110	8220		9110	9220	H7017	H7068	N8017	N8068	B8517	B8568	M9517	M9568	6
KIT NOTES: W7. Must have 3-Bolt Steering Knuckle. W14. Adjustable Drag Link # DL10 Recommended to Replace Factory Non-Adjustable Link on 72-93 Models. W15. If Vehicle is Equipped with a Front Sway Bar. Lowering Brackets must be Ordered. See Dodge Accessories Section. W16. See Brake Lines Section.																												
<b>72-74 W150 &amp; W250 Pickup 4WD Full-Size System With 52" Replacement Rear Springs</b>																												
4"	D400AKS	W7, W10, W14, W15, W16	D240AS	2	D400S	2	DR60S		DA60			7110	7220		8110	8220		9110	9220	H7017	H7038	N8017	N8038	B8517	B8538	M9517	M9538	4
6"	D600AKS	W7, W14, W15, W16	D680AS	2	D600S	2	DR40S		DA60			7110	7220		8110	8220		9110	9220	H7017	H7068	N8017	N8068	B8517	B8568	M9517	M9568	6
8"	D800AKS	W7, W15, W16	D680AS	2	D800S	2	DR60S		DA65 + DL10			7110	7220		8110	8220		9110	9220	H7036	H7068	N8036	N8068	B8536	B8568	M9536	M9568	8
KIT NOTES: W1. This Kit Uses Add-A-Leafs Instead of Block & U-Bolt Kit for the Rear. W7. Must have 3-Bolt Steering Knuckle. W10. The Factory Block is Removed. W14. Adjustable Drag Link # DL10 Recommended to Replace Factory Non-Adjustable Link on 72-93 Models. W15. If Vehicle is Equipped with a Front Sway Bar. Lowering Brackets must be Ordered. See Dodge Accessories Section. W16. See Brake Lines Section.																												
<b>14-18 2500 &amp; 3500 RAM 4WD ALL ENGINES NOTE: ALL SHOCKS MUST BE ORDERED SEPARATELY</b>																												
<b>14-18 2500 Ram Pickup 4WD (All Engines) Metal Spacers (Front Leveling Kit)</b>																												
2"	R1325MS		R1325MS									7014			8014			9014		H7091	H7092	N8091	N8092	B8591	B8592	M9591	M9592	2
2"	R1325MSB	W31	R1325MSB									7014			8014			9014		H7092		N8092		B8592		M9592	2	
KIT NOTES: W31. Front Shock Extension Brackets Included.																												
<b>94-18 DODGE RAM 2500 &amp; 3500 2WD</b>																												
<b>94-18 Dodge Ram 2500 &amp; 3500 2WD Leveling Spacer Kit</b>																												
2"	D220MS	W2	D220MS																	----	----	----	----	----	----	----	----	2
KIT NOTES: W2. Will NOT fit Air Ride.																												
<b>13-18 3500 Ram Pickup 4WD (All Engines) Metal Spacers (Front Leveling Kit)</b>																												
2"	R1325MS		R1325MS									7014			8014			9014		H7091	H7070	N8091	N8070	B8591	B8570	M9591	M9570	2
2"	R1325MSB	W31	R1325MSB									7014			8014			9014		H7070		N8070		B8570		M9570	2	
KIT NOTES: W31. Front Shock Extension Brackets Included.																												
<b>14-18 2500 Ram Pickup 4WD (Diesel Engine Only) Coil Springs (Front Leveling Kit)</b>																												
2-2.5"	R25			1	R25							7014			8014			9014		H7091	H7092	N8091	N8092	B8591	B8592	M9591	M9592	1.5
<b>13-18 3500 Ram Pickup 4WD (Diesel Engine Only) Coil Springs (Front Leveling Kit)</b>																												
2-2.5"	R25			1	R25							7014			8014			9014		H7091	H7070	N8091	N8070	B8591	B8570	M9591	M9570	1.5
<b>14-18 2500 RAM 4WD WITH DIESEL ENGINES NOTE: ALL SHOCKS MUST BE ORDERED SEPARATELY</b>																												
<b>14-18 2500 Ram Pickup 4WD Kit Kit with Front &amp; Rear Coil Springs</b>																												
4"	R14451K	Does Not Fit Airbag Models	R461 + R144C	1	R45							7014	7214	8014	8214	9014	9214	H7092	H7093	N8092	N8093	B8592	B8593	M9592	M95932	8		
<b>14-18 2500 Ram Pickup 4WD Kit Kit with Front &amp; Rear Coil Springs</b>																												
6"	R14651K	Does Not Fit Airbag Models	R461 + R146C	1	R65							7014	7214	8014	8214	9014	9214	H7093	H7094	N8093	N8094	B8593	B8594	M9593	M95942	8		
<b>13-18 3500 RAM 4WD WITH DIESEL ENGINES NOTE: ALL SHOCKS MUST BE ORDERED SEPARATELY</b>																												
<b>13-18 3500 Ram Pickup 4WD Kit Front Coil Springs &amp; Rear Blocks &amp; U-Bolts</b>																												
3.5-4"	R13451K		R461 + R134	1	R45							7014	7214	8014	8214	9014	9214	H7092	H7090	N8092	N8090	B8592	B8590	M9592	M9590	6		
<b>13-18 3500 Ram Pickup 4WD Kit Front Coil Springs &amp; Rear Blocks &amp; U-Bolts</b>																												
5.5-6"	R13651K		R461 + R136	1	R65							7014	7214	8014	8214	9014	9214	H7093	H7090	N8093	N8090	B8593	B8590	M9593	M9590	6		

DODGE / RAM

DODGE / RAM



LIFT	Quick Kit Reference	KIT NOTES	Component Box (Requires 1 of Each)	Front Springs		Rear Springs		Add-A-Leafs	Steering Correction (Order 1 Each)	Steering Stabilizers						HYDRO Shocks		NITRO Shocks		BLACK MAX		M95 Shocks		Labor Hours																									
				Qty	Part #	Qty	Part #			White			Black			Silver			White		White		Black		Silver																								
										OEM	Single	Dual	OEM	Single	Dual	OEM	Single	Dual	Front	Rear	Front	Rear	Front		Rear	Front	Rear	Front	Rear																				
<b>10-13 2500 &amp; 10-12 3500 RAM 4WD WITH DIESEL ENGINES</b>																									<b>NOTE: ALL SHOCKS MUST BE ORDERED SEPARATELY</b>																								
<b>VALUE KITS</b>																																																	
<b>10-13 2500 &amp; 10-12 3500 Ram Pickup 4WD Kit Metal Spacers with Rear Add-A-Leafs</b>																																																	
2.5"	D27MK		D25MS					R332		7013			8013			9013			H7092	H7036	N8092	N8036	B8592	B8536	M9592	M9536	4																						
<b>10-13 2500 &amp; 10-12 3500 Ram Pickup 4WD &amp; Mega Cab Kit Polyurethane Spacers with Rear Add-A-Leafs</b>																																																	
2"	D27PK		D20P					R332		7013			8013			9013			H7092	H7036	N8092	N8036	B8592	B8536	M9592	M9536	4																						
<b>94-18 DODGE RAM 2500 &amp; 3500 2WD</b>																																																	
<b>94-18 Dodge Ram 2500 &amp; 3500 2WD Leveling Spacer Kit</b>																																																	
2"	D220MS	W2	D220MS																---	---	---	---	---	---	---	---	2																						
KIT NOTES: W2. Will NOT fit Air Ride.																																																	
<b>STANDARD SERIES</b>																																																	
<b>10-13 2500 &amp; 10-12 3500 Ram Pickup 4WD &amp; Mega Cab Kit Class I with Add-A-Leafs</b>																																																	
3.5-4"	D2513K	W28	D2513	1	D25			Included		7013		7239	8013		8239	9013		9239	H7092	H7036	N8092	N8036	B8592	B8536	M9592	M9536	6																						
<b>10-13 2500 &amp; 10-13 3500 Ram Pickup 4WD Kit Class I with Add-A-Leafs</b>																																																	
6"	D4510K	W22, W23, W24	D45510 + D4513	1	D45			Included	Included	Included		7239	8013		8239	9013		9239	H7094	H7036	N8094	N8036	B8594	B8536	M9594	M9536	9																						
KIT NOTES: W22. Some Models may Require Indexing Ring Part # IXR20K if a Front Driveline Vibration Develops. W23. If Vehicle is Equipped with a Sterling Rear Axle, Rear U-Bolt Kit Part # U9B12R must be Ordered Separately. W24. On Models with a Rear Carrier Bearing, if a Rear Driveline Vibration Occurs Carrier Bearing Drop Brackets are Available. 1" Drop Part # CBL3401, 2 1/4" Drop Part # CBL214. W28. V8 Gas Engines, Order Part # D30 Coils.																																																	
<b>10-13 2500 &amp; 10-12 3500 Ram Pickup 4WD System Class I with Rear Springs</b>																																																	
6"	D4510KS	W22, W23, W24	D45510 + D4513S	1	D45	2	DR174S	Included	Included	Included		7239	8013		8239	9013		9239	H7094	H7036	N8094	N8036	B8594	B8536	M9594	M9536	9																						
KIT NOTES: W22. Some Models may Require Indexing Ring Part # IXR20K if a Front Driveline Vibration Develops. W23. If Vehicle is Equipped with a Sterling Rear Axle, Rear U-Bolt Kit Part # U9B12R must be Ordered Separately. W24. On Models with a Rear Carrier Bearing, if a Rear Driveline Vibration Occurs Carrier Bearing Drop Brackets are Available. 1" Drop Part # CBL3401, 2 1/4" Drop Part # CBL214.																																																	
<b>2009 2500 &amp; 3500 RAM 4WD &amp; MEGA CAB WITH DIESEL ENGINES</b>																									<b>NOTE: ALL SHOCKS MUST BE ORDERED SEPARATELY</b>																								
<b>VALUE KITS</b>																																																	
<b>2009 2500 &amp; 3500 Ram Pickup 4WD Kit Metal Spacers with Rear Add-A-Leafs</b>																																																	
2.5"	D27MK		D25MS					R332		7013			8013			9013			H7092	H7036	N8092	N8036	B8592	B8536	M9592	M9536	4																						
<b>2009 2500 &amp; 3500 Ram Pickup 4WD &amp; Mega Cab Kit Polyurethane Spacers with Rear Add-A-Leafs</b>																																																	
2"	D27PK		D20P					R332		7013			8013			9013			H7092	H7036	N8092	N8036	B8592	B8536	M9592	M9536	4																						
<b>94-18 DODGE RAM 2500 &amp; 3500 2WD</b>																																																	
<b>94-18 Dodge Ram 2500 &amp; 3500 2WD Leveling Spacer Kit</b>																																																	
2"	D220MS	W2	D220MS																---	---	---	---	---	---	---	---	2																						
KIT NOTES: W2. Will NOT fit Air Ride.																																																	
<b>STANDARD SERIES</b>																																																	
<b>2009 2500 &amp; 3500 Ram Pickup 4WD &amp; Mega Cab Kit Class I with Add-A-Leafs</b>																																																	
3.5-4"	D2513K	W28	D2513	1	D25			Included		7013		7239	8013		8239	9013		9239	H7092	H7036	N8092	N8036	B8592	B8536	M9592	M9536	6																						
<b>2009 2500 &amp; 3500 Ram Pickup 4WD &amp; Mega Cab Kit Class I with Add-A-Leafs</b>																																																	
6"	D4519K	W22, W23, W24	D45529 + D4513	1	D45			Included	Included			7239			8239			9239	H7094	H7036	N8094	N8036	B8594	B8536	M9594	M9536	9																						
KIT NOTES: W22. Some Models may Require Indexing Ring Part # IXR20K if a Front Driveline Vibration Develops. W23. If Vehicle is Equipped with a Sterling Rear Axle, Rear U-Bolt Kit Part # U9B12R must be Ordered Separately. W24. On Models with a Rear Carrier Bearing, if a Rear Driveline Vibration Occurs Carrier Bearing Drop Brackets are Available. 1" Drop Part # CBL3401, 2 1/4" Drop Part # CBL214.																																																	
<b>2009 2500 &amp; 1 Ram Pickup 4WD &amp; Mega Cab System Class I with Rear Springs</b>																																																	
6"	D4519KS	W22, W23, W24	D45529 + D4513S	1	D45	2	DR374S	Included	Included	Included		7239	8013		8239	9013		9239	H7094	H7036	N8094	N8036	B8594	B8536	M9594	M9536	9																						
KIT NOTES: W22. Some Models may Require Indexing Ring Part # IXR20K if a Front Driveline Vibration Develops. W23. If Vehicle is Equipped with a Sterling Rear Axle, Rear U-Bolt Kit Part # U9B12R must be Ordered Separately. W24. On Models with a Rear Carrier Bearing, if a Rear Driveline Vibration Occurs Carrier Bearing Drop Brackets are Available. 1" Drop Part # CBL3401, 2 1/4" Drop Part # CBL214.																																																	
<b>2009 2500 &amp; 3500 Ram Pickup 4WD &amp; Mega Cab Kit Class II with Add-A-Leafs</b>																																																	
6"	D4529K	W22, W23, W24	D45529 + D4523	1	D45			Included	Included	Included		7239	8013		8239	9013		9239	H7094	H7036	N8094	N8036	B8594	B8536	M9594	M9536	10																						
KIT NOTES: W22. Some Models may Require Indexing Ring Part # IXR20K if a Front Driveline Vibration Develops. W23. If Vehicle is Equipped with a Sterling Rear Axle, Rear U-Bolt Kit Part # U9B12R must be Ordered Separately. W24. On Models with a Rear Carrier Bearing, if a Rear Driveline Vibration Occurs Carrier Bearing Drop Brackets are Available. 1" Drop Part # CBL3401, 2 1/4" Drop Part # CBL214.																																																	
<b>2009 2500 &amp; 3500 Ram Pickup 4WD &amp; Mega Cab Kit Class II with Rear Springs</b>																																																	
6"	D4529KS	W22, W23, W24	D45529 + D4523S	1	D45	2	DR374S	Included	Included	Included		7239	8013		8239	9013		9239	H7094	H7036	N8094	N8036	B8594	B8536	M9594	M9536	10																						
KIT NOTES: W22. Some Models may Require Indexing Ring Part # IXR20K if a Front Driveline Vibration Develops. W23. If Vehicle is Equipped with a Sterling Rear Axle, Rear U-Bolt Kit Part # U9B12R must be Ordered Separately. W24. On Models with a Rear Carrier Bearing, if a Rear Driveline Vibration Occurs Carrier Bearing Drop Brackets are Available. 1" Drop Part # CBL3401, 2 1/4" Drop Part # CBL214.																																																	

DODGE / RAM

DODGE / RAM



LIFT	Quick Kit	KIT NOTES	Component Box	Front Springs		Rear Springs		Add-A-Leafs	Steering Correction	Steering Stabilizers									HYDRO Shocks		NITRO Shocks		BLACK MAX		M95 Shocks		Labor			
				Qty	Part #	Qty	Part #			White			Black			Silver			White		White		Black		Silver					
										OEM	Single	Dual	OEM	Single	Dual	OEM	Single	Dual	Front	Rear	Front	Rear	Front	Rear	Front	Rear		Front	Rear	Hours
<b>00-02 2500 &amp; 3500 Ram Pickup 4WD Kit</b>																														
<b>Class II with Add-A-Leafs</b>																														
5"	D4522K	W6, W12, W22, W24	D4552 + D452	1	D45			Included	Included			Included		7218	8007		8218	9007		9218	H7094	H7036	N8094	N8036	B8594	B8536	M9594	M9536	10	
KIT NOTES: W6. Class II Includes Front Dual Shock Brackets, Upper Links & Lower Link Skid Plates. W12. Models Equipped with a 'Towing Package' REQUIRED Longer U-Bolts. If so Equipped, Order # D452H Instead of # D452. W22. Some Models may Require Indexing Ring Part # IXR20K if a Front Driveline Vibration Develops. W24. On Models with a Rear Carrier Bearing, if a Rear Driveline Vibration Occurs Carrier Bearing Drop Brackets are Available. 1" Drop Part # CBL3401, 2 1/4" Drop Part # CBL214. (Gas Engines will Receive More Lift than Diesel). DUAL STABILIZER NOTE: For 00-02 with 3.75" Axle Tube Use Part # 7270. For 00-02 Models with 3" Axle Tube Use Part # 7218.																														
<b>00-02 2500 &amp; 3500 Ram Pickup 4WD System</b>																														
<b>Class II with Replacement Rear Springs</b>																														
5"	D4522KS	W6, W22, W24	D4552 + D452S	1	D45	2	DR74S		Included			Included		7218	8007		8218	9007		9218	H7094	H7036	N8094	N8036	B8594	B8536	M9594	M9536	10	
KIT NOTES: W6. Class II Includes Front Dual Shock Brackets, Upper Links & Lower Link Skid Plates. W22. Some Models may Require Indexing Ring Part # IXR20K if a Front Driveline Vibration Develops. W24. On Models with a Rear Carrier Bearing, if a Rear Driveline Vibration Occurs Carrier Bearing Drop Brackets are Available. 1" Drop Part # CBL3401, 2 1/4" Drop Part # CBL214. (Gas Engines will Receive More Lift than Diesel). DUAL STABILIZER NOTE: For 00-02 with 3.75" Axle Tube Use Part # 7270. For 00-02 Models with 3" Axle Tube Use Part # 7218.																														
<b>00-02 2500 &amp; 3500 RAM 4WD FOR MODELS WITH V10 / CUMMINS ENGINE EQUIPPED WITH 3" WIDE REAR SPRINGS</b>																														
<b>NOTE: ALL SHOCKS MUST BE ORDERED SEPARATELY</b>																														
<b>LONG ARM SERIES</b>																														
<b>00-02 2500 &amp; 3500 Ram Pickup 4WD Kit</b>																														
<b>With Blocks &amp; U-Bolts &amp; Add-A-Leafs</b>																														
7"	D752K-DX	W6, W25, W26, W27, W30	D7075-DX+D752	1	D75			Included	DA602			Included		(W13)			(W13)		(W13)	H7038	H7078	N8038	N8078	B8538	B8578	M9538	M9578	12		
KIT NOTES: W6. Class II Includes Front Dual Shock Brackets, Upper Links & Lower Link Skid Plates. W25. Seal Adapter Part # D752K and Seal Part # TCS2675 are Included. W26. 6 Speed Models will Require Modifications to Transmission Bracket. W27. 2500 & 3500 Models with a 360 Engine will Sit Slightly Higher in the Front. W30. Brake Line Brackets Included. (Gas Engines will Receive More Lift than Diesel). W13. See Steering Stabilizer Section for Year, Make, Model Fitment.																														
<b>00-02 2500 &amp; 3500 Ram Pickup 4WD System</b>																														
<b>With Replacement Rear Springs</b>																														
7"	D752KS-DX	W6, W25, W26, W27, W30	D7075-DX+D752S	1	D75	2	DR76S		DA602			Included		(W13)			(W13)		(W13)	H7038	H7078	N8038	N8078	B8538	B8578	M9538	M9578	12		
KIT NOTES: W6. Class II Includes Front Dual Shock Brackets, Upper Links & Lower Link Skid Plates. W25. Seal Adapter Part # D752KS and Seal Part # TCS2675 are Included. W26. 6 Speed Models will Require Modifications to Transmission Bracket. W27. 2500 & 3500 Models with a 360 Engine will Sit Slightly Higher in the Front. W30. Brake Line Brackets Included. (Gas Engines will Receive More Lift than Diesel). W13. See Steering Stabilizer Section for Year, Make, Model Fitment.																														
<b>94-99 2500 &amp; 3500 RAM 4WD FOR MODELS WITH V10 / CUMMINS ENGINE EQUIPPED WITH 3" WIDE REAR SPRINGS</b>																														
<b>NOTE: ALL SHOCKS MUST BE ORDERED SEPARATELY</b>																														
<b>VALUE KITS</b>																														
<b>94-99 2500 &amp; 3500 Ram Pickup 4WD Kit</b>																														
<b>Metal Spacers with Rear Add-A-Leafs</b>																														
2.5"	D25MK		D25MS						R372				7007			8007			9007			H7092	H7036	N8092	N8036	B8592	B8536	M9592	M9536	4
<b>94-99 2500 &amp; 3500 Ram Pickup 4WD Kit</b>																														
<b>Polyurethane Spacers with Rear Add-A-Leafs</b>																														
2"	D25PK		D20P						R372				7007			8007			9007			H7092	H7036	N8092	N8036	B8592	B8536	M9592	M9536	4
<b>94-18 DODGE RAM 2500 &amp; 3500 2WD</b>																														
<b>94-18 Dodge Ram 2500 &amp; 3500 2WD</b>																														
<b>Leveling Spacer Kit</b>																														
2"	D220MS	W2	D220MS																											2
KIT NOTES: W2. Will NOT fit Air Ride.																														
<b>STANDARD SERIES</b>																														
<b>94-99 2500 &amp; 3500 Ram Pickup 4WD Kit</b>																														
<b>Class I with Add-A-Leafs</b>																														
2-2.5"	D251K		D251	1	D25			Included				7007		(W13)	8007		(W17)	9007		(W29)	H7092	H7036	N8092	N8036	B8592	B8536	M9592	M9536	6	
4-4.5"	D451K	W9, W22, W24	D4550 + D451	1	D45			Included	Included			Included		(W13)			(W17)		(W29)	H7094	H7036	N8094	N8036	B8594	B8536	M9594	M9536	9		
KIT NOTES: W9. Models Equipped with a 'Towing Package' REQUIRE Longer U-Bolts. If so Equipped, Order # D451H Instead of # D451. W22. Some Models may Require Indexing Ring Part # IXR20K if a Front Driveline Vibration Develops. W24. On Models with a Rear Carrier Bearing, if a Rear Driveline Vibration Occurs Carrier Bearing Drop Brackets are Available. 1" Drop Part # CBL3401, 2 1/4" Drop Part # CBL214. (Gas Engines will Receive More Lift than Diesel). W13. On 94-97 Models Use # 7217 Steering Stabilizer. On 98-99 Models with 3" Axle Tube Use # 7218. On 98-99 Models with 3.75" Axle Tube Use # 7270. W17. On 94-97 Models Use # 8217 Steering Stabilizer. On 98-99 Models with 3" Axle Tube Use # 8218. On 98-99 Models with 3.75" Axle Tube Use # 8270. W29. On 94-97 Models Use # 9217 Steering Stabilizer. On 98-99 Models with 3" Axle Tube Use # 9218. On 98-99 Models with 3.75" Axle Tube Use # 9270.																														
<b>94-99 2500 &amp; 3500 Ram Pickup 4WD System</b>																														
<b>Class I with Replacement Rear Springs</b>																														
4-4.5"	D451KS	W22, W24	D4550 + D451S	1	D45	2	DR74S		Included			Included		(W13)			(W17)		(W29)	H7094	H7036	N8094	N8036	B8594	B8536	M9594	M9536	9		
KIT NOTES: W10. The Factory Block is Removed. W22. Some Models may Require Indexing Ring Part # IXR20K if a Front Driveline Vibration Develops. W24. On Models with a Rear Carrier Bearing, if a Rear Driveline Vibration Occurs Carrier Bearing Drop Brackets are Available. 1" Drop Part # CBL3401, 2 1/4" Drop Part # CBL214. (Gas Engines will Receive More Lift than Diesel). W13. On 94-97 Models Use # 7217 Steering Stabilizer. On 98-99 Models with 3" Axle Tube Use # 7218. On 98-99 Models with 3.75" Axle Tube Use # 7270. W17. On 94-97 Models Use # 8217 Steering Stabilizer. On 98-99 Models with 3" Axle Tube Use # 8218. On 98-99 Models with 3.75" Axle Tube Use # 8270. W29. On 94-97 Models Use # 9217 Steering Stabilizer. On 98-99 Models with 3" Axle Tube Use # 9218. On 98-99 Models with 3.75" Axle Tube Use # 9270.																														
<b>94-99 2500 &amp; 3500 RAM 4WD FOR MODELS WITH V10 / CUMMINS ENGINE EQUIPPED WITH 3" WIDE REAR SPRINGS</b>																														
<b>NOTE: ALL SHOCKS MUST BE ORDERED SEPARATELY</b>																														
<b>94-99 2500 &amp; 3500 Ram Pickup 4WD Kit</b>																														
<b>Class II with Add-A-Leafs</b>																														
4-4.5"	D452K	W6, W12, W22, W24	D4550 + D452	1	D45			Included	Included			Included		(W13)			(W13)		(W13)	H7094	H7036	N8094	N8036	B8594	B8536	M9594	M9536	10		
KIT NOTES: W6. Class II Includes Front Dual Shock Brackets, Upper Links & Lower Link Skid Plates. W12. Models Equipped with a 'Towing Package' REQUIRED Longer U-Bolts. If so Equipped, Order # D452H Instead of # D452. W22. Some Models may Require Indexing Ring Part # IXR20K if a Front Driveline Vibration Develops. W24. On Models with a Rear Carrier Bearing, if a Rear Driveline Vibration Occurs Carrier Bearing Drop Brackets are Available. 1" Drop Part # CBL3401, 2 1/4" Drop Part # CBL214. (Gas Engines will Receive More Lift than Diesel). W13. See Steering Stabilizer Section for Year, Make, Model Fitment.																														

DODGE / RAM

DODGE / RAM

LIFT	Quick Kit	KIT NOTES	Component Box (Requires 1 of Each)	Front Springs		Rear Springs		Add-A-Leafs	Steering Correction (Order 1 Each)	Steering Stabilizers						HYDRO Shocks		NITRO Shocks		BLACK MAX		M95 Shocks		Labor Hours			
				Qty	Part #	Qty	Part #			White			Black			Silver			White		White		Black		Silver		
										OEM	Single	Dual	OEM	Single	Dual	OEM	Single	Dual	OEM	Single	Dual	Front	Rear		Front	Rear	Front
<b>94-99 2500 &amp; 3500 Ram Pickup 4WD System</b> <b>Class II with Replacement Rear Springs</b>																											
4-4.5"	D452KS	W6, W22, W24	D4550 + D452S	1	D45	2	DR74S		Included	Included		(W13)			(W17)			(W29)	H7094 H7041	H7036 N8041	N8094 N8041	N8036 N8036	B8594 B8541	B8536 B8536	M9594 M9541	M9536 M9541	10

KIT NOTES: W6. Class II Includes Front Dual Shock Brackets, Upper Links & Lower Link Skid Plates. SW22. Some Models may Require Indexing Ring Part # IXR20K if a Font Driveline Vibration Develops. W24. On Models with a Rear Carrier Bearing, if a Rear Driveline Vibration Occurs Carrier Bearing Drop Brackets are Available. 1" Drop Part # CBL3401, 2 1/4" Drop Part # CBL214. (Gas Engines will Receive More Lift than Diesel).  
W13. See Steering Stabilizer Section for Year, Make, Model Fitment.  
Must Order 2 of each Front Shock and 2 Rear Shocks.

**94-99 2500 & 3500 RAM 4WD FOR MODELS WITH V10 / CUMMINS ENGINE EQUIPPED WITH 3" WIDE REAR SPRINGS** **NOTE: ALL SHOCKS MUST BE ORDERED SEPARATELY**

<b>LONG ARM SERIES</b>																											
<b>94-99 2500 &amp; 3500 Ram Pickup 4WD Kit</b> <b>With Blocks &amp; U-Bolts &amp; Add-A-Leafs</b>																											
7"	D752K-DX	W6, W25, W26, W27,W30	D7075-DX+D752	1	D75			Included	DA600	Included		7217			8217			9217	H7038 H7060	H7078 N8060	N8038 N8060	N8078 N8078	B8538 B8560	B8578 B8578	M9538 M9560	M9578 M9560	12
KIT NOTES: W6. Class II Includes Front Dual Shock Brackets, Upper Links & Lower Link Skid Plates. Must Order 2 QUAD Shocks Separately. W25. Seal Adapter Part # DTSA10 & Seal Part # TCS2675 are Included. W26. 6 Speed Models will Require Modifications to Transmission Bracket. W27. 2500 & 3500 Models with a 360 Engine will Sit Slightly Higher in the Front. W30. Brake Line Brackets Included. (Gas Engines will Receive More Lift than Diesel). DUAL STABILIZER NOTE: For 98-99 with 3.75" Axle Tube Use Part # 7270 / 8270 / 9270. For 98-99 Models with 3" Axle Tube Use Part # 7218 / 8218 / 9218. Must Order 2 of each Front Shock and 2 Rear Shocks.																											

<b>94-99 2500 &amp; 3500 Ram Pickup 4WD System</b> <b>With Replacement Rear Springs</b>																											
7"	D752KS-DX	W6, W25, W26, W27,W30	D7075-DX+D752S	1	D75	2	DR76S		DA600	Included		7217			8217			9217	H7038 H7060	H7078 N8060	N8038 N8060	N8078 N8078	B8538 B8560	B8578 B8578	M9538 M9560	M9578 M9560	12
KIT NOTES: W6. Class II Includes Front Dual Shock Brackets, Upper Links & Lower Link Skid Plates. Must Order 2 QUAD Shocks Separately. W25. Seal Adapter Part # DTSA10 & Seal Part # TCS2675 are Included. W26. 6 Speed Models will Require Modifications to Transmission Bracket. W27. 2500 & 3500 Models with a 360 Engine will Sit Slightly Higher in the Front. W30. Brake Line Brackets Included. (Gas Engines will Receive More Lift than Diesel). DUAL STABILIZER NOTE: For 98-99 with 3.75" Axle Tube Use Part # 7270 / 8270 / 9270. For 98-99 Models with 3" Axle Tube Use Part # 7218 / 8218 / 9218. Must Order 2 of each Front Shock and 2 Rear Shocks.																											

**92-93 W250 & W350 4WD FULL-SIZE WITH CUMMINS DIESEL ENGINES** **NOTE: ALL SHOCKS MUST BE ORDERED SEPARATELY**

<b>92-93 W250 &amp; W350 Pickup 4WD Full-Size Kit</b> <b>With Blocks &amp; U-Bolts &amp;/or Add-A-Leafs</b>																												
1"	D100CDK	W1, W14	D240CDA	2	D100CS			R1120				7110	7220		8110	8220		9110	9220	H7047	H7038	N8047	N8038	B8547	B8538	M9547	M9538	4
2.5"	D200CDAK	W1, W14	D240CDA	2	D200CS			R225				7110	7220		8110	8220		9110	9220	H7027	H7038	N8027	N8038	B8527	B8538	M9527	M9538	4
4"	D400CDAK	W1, W14, W15	D240CDA	2	D400CS			R225	DA20			7110	7220		8110	8220		9110	9220	H7017	H7038	N8017	N8038	B8517	B8538	M9517	M9538	4
6"	D692CDK	W15, W16	D692CD	2	D600CS			R225	DA45			7110	7220		8110	8220		9110	9220	H7017	H7068	N8017	N8068	B8517	B8568	M9517	M9568	6
KIT NOTES: W1. This Kit Uses Add-A-Leafs Instead of Block & U-Bolt Kit for the Rear. W14. Adjustable Drag Link # DL10 Recommended to Replace Factory Non-Adjustable Link on 72-93 Models. W15. If Vehicle is Equipped with a Front Sway Bar. Lowering Brackets must be Ordered. See Dodge Accessories Section. W16. See Brake Lines Section.																												

<b>92-93 W250 &amp; W3500 Pickup 4WD Full-Size System</b> <b>With Replacement Rear Springs</b>																												
1"	D192CDKS	W10, W14, W17	D240CDS	2	D100CS	2	DR60S					7110	7220		8110	8220		9110	9220	H7047	H7038	N8047	N8038	B8547	B8538	M9547	M9538	4
2.5"	D292CDKS	W10, W14, W17	D240CDS	2	D200CS	2	DR60S					7110	7220		8110	8220		9110	9220	H7027	H7038	N8027	N8038	B8527	B8538	M9527	M9538	4
4"	D492CDKS	W3, W14, W15, W17	D492CDS	2	D400CS	2	DR60S		DA20			7110	7220		8110	8220		9110	9220	H7017	H7038	N8017	N8038	B8517	B8538	M9517	M9538	4
6"	D692CDKS	W4, W14, W15, W16, W17	D692CDS	2	D600CS	2	DR60S		DA45			7110	7220		8110	8220		9110	9220	H7017	H7068	N8017	N8068	B8517	B8568	M9517	M9568	6
KIT NOTES: W3. The 6" Factory Blocks are Replaced with 2" Blocks. W4. The 6" Factory Blocks are Replaced with 4.5" Blocks. W10. The Factory Block is Removed. W14. Adjustable Drag Link # DL10 Recommended to Replace Factory Non-Adjustable Link on 72-93 Models. W15. If Vehicle is Equipped with a Front Sway Bar. Lowering Brackets must be Ordered. See Dodge Accessories Section. W16. See Brake Lines Section. W17- Requires SE170D for DR60S																												

**87-91 W250 & W350 4WD FULL-SIZE LEAF SPRING FRONT WITH CUMMINS DIESEL ENGINES** **NOTE: ALL SHOCKS MUST BE ORDERED SEPARATELY**

<b>87-91 W250 &amp; W350 Pickup 4WD Full-Size Kit</b> <b>With Blocks &amp; U-Bolts</b>																												
2.5"	D200CDK	W14, W16	D240CD	2	D200CS							7110	7220		8110	8220		9110	9220	H7027	H7038	N8027	N8038	B8527	B8538	M9527	M9538	4
4"	D400CDK	W14, W15, W16	D240CD	2	D400CS				DA20			7110	7220		8110	8220		9110	9220	H7017	H7038	N8017	N8038	B8517	B8538	M9517	M9538	4
6"	D600CDK	W14, W15, W16	D600CD	2	D600CS				DA45			7110	7220		8110	8220		9110	9220	H7017	H7068	N8017	N8068	B8517	B8568	M9517	M9568	6
KIT NOTES: W14. Adjustable Drag Link # DL10 Recommended to Replace Factory Non-Adjustable Link on 72-93 Models. W15. If Vehicle is Equipped with a Front Sway Bar. Lowering Brackets must be Ordered. See Dodge Accessories Section. W16. See Brake Lines Section.																												

<b>87-91 W250 &amp; W350 Pickup 4WD Full-Size Kit</b> <b>With Add-A-Leafs</b>																												
1"	D100CDK	W1, W14, W16	D240CDA	2	D100CS			R1120				7110	7220		8110	8220		9110	9220	H7047	H7038	N8027	N8038	B8527	B8538	M9547	M9538	4
2.5"	D200CDAK	W1, W14, W16	D240CDA	2	D200CS			R225				7110	7220		8110	8220		9110	9220	H7027	H7038	N8017	N8038	B8517	B8538	M9527	M9538	4
4"	D400CDAK	W1, W14, W15, W16	D240CDA	2	D400CS			R225	DA20			7110	7220		8110	8220		9110	9220	H7017	H7038	N8017	N8068	B8517	B8568	M9517	M9538	4
KIT NOTES: W1. This Kit Uses Add-A-Leafs Instead of Block & U-Bolt Kit for the Rear. W14. Adjustable Drag Link # DL10 Recommended to Replace Factory Non-Adjustable Link on 72-93 Models. W15. If Vehicle is Equipped with a Front Sway Bar. Lowering Brackets must be Ordered. See Dodge Accessories Section. W16. See Brake Lines Section.																												

<b>87-91 W250 &amp; W350 Pickup 4WD Full-Size System</b> <b>With Replacement Rear Springs</b>																												
1"	D100CDKS	W10, W14, W16	D240CDS	2	D100CS	2	DR40S					7110	7220		8110	8220		9110	9220	H7047	H7038	N8047	N8038	B8547	B8538	M9547	M9538	4
2.5"	D200CDKS	W10, W14, W16	D240CDS	2	D200CS	2	DR40S					7110	7220		8110	8220		9110	9220	H7027	H7038	N8027	N8038	B8527	B8538	M9527	M9538	4
6"	D600CDKS	W15, W16	D600CDS	2	D600CS	2	DR40S		DA45			7110	7220		8110	8220		9110	9220	H7017	H7068	N8017	N8068	B8517	B8568	M9517	M9568	6
KIT NOTES: W10. The Factory Block is Removed. W14. Adjustable Drag Link # DL10 Recommended to Replace Factory Non-Adjustable Link on 72-93 Models. W15. If Vehicle is Equipped with a Front Sway Bar. Lowering Brackets must be Ordered. See Dodge Accessories Section. W16. See Brake Lines Section.																												

DODGE / RAM

DODGE / RAM

LIFT	Quick Kit Reference	KIT NOTES	Component Box (Requires 1 of Each)	Front Springs		Rear Springs		Add-A-Leafs	Steering Correction (Order 1 Each)	Steering Stabilizers						HYDRO Shocks		NITRO Shocks		BLACK MAX		M95 Shocks		Labor Hours
				Qty	Part #	Qty	Part #			White		Black		Silver		White		Black		Silver				
				OEM	Single	Dual	OEM			Single	Dual	OEM	Single	Dual	OEM	Single	Dual	Front	Rear	Front	Rear	Front	Rear	
<b>87-91 W250 &amp; W350 Pickup 4WD Full-Size System With FULL-Height Replacement Rear Springs</b>																								
2.5"	D292CDKS	W10, W14, W16	D240CDS	2	D200CS	2	DR60S			7110	7220	8110	8220	9110	9220	H7027	H7038	N8027	N8038	B8527	B8538	M9527	M9538	4
4"	D400CDKS4	W14, W15, W16	D600CDS	2	D400CS	2	DR40S		DA20	7110	7220	8110	8220	9110	9220	H7017	H7068	N8017	N8068	B8517	B8568	M9517	M9568	4
6"	D600CDKS6	W14, W15, W16	D600CDS	2	D600CS	2	DR60S		DA45	7110	7220	8110	8220	9110	9220	H7017	H7068	N8017	N8068	B8517	B8568	M9517	M9568	6

KIT NOTES: W10. The Factory Block is Removed. W14. Adjustable Drag Link # DL10 Recommended to Replace Factory Non-Adjustable Link on 72-93 Models. W15. If Vehicle is Equipped with a Front Sway Bar. Lowering Brackets must be Ordered. See Dodge Accessories Section. W16. See Brake Lines Section.

**74.5-93 RAMCHARGER, TRAILDUSTER 4WD NOTE: ALL SHOCKS MUST BE ORDERED SEPARATELY**

<b>74.5-93 Ramcharger, Trailduster 4WD Kit With Blocks &amp; U-Bolts &amp;/or Add-A-Leafs</b>																								
2.5"	D200BK	W2, W14, W16	D240B	2	D200S				DA20	7110	7220	8110	8220	9110	9220	H7027	H7038	N8027	N8038	B8527	B8538	M9527	M9538	4
4"	D400BRK	W2, W14, W15, W16	D400BR	2	D400S				DA40	7110	7220	8110	8220	9110	9220	H7017	H7038	N8017	N8038	B8517	B8538	M9517	M9538	4
6"	D600BRK	W14, W15, W16	D680BR	2	D600S				DA60	7110	7220	8110	8220	9110	9220	H7017	H7068	N8017	N8068	B8517	B8568	M9517	M9568	6
8"	D800BRK	W2, W5, W15, W16	D680BR	2	D800S		R1120		DA40 + DA60	7110	7220	8110	8220	9110	9220	H7036	H7068	N8036	N8068	B8536	B8568	M9536	M9568	8

KIT NOTES: W2. Pitman Arm Fits 78-93 Models Only (74.5-77 Models Use Part # DA60 on 4" Lifts). Steering Correction (See Steering Components Section). W5. 74.5-77 Models MUST Use # DA65 & # DL10. W14. Adjustable Drag Link # DL10 Recommended to Replace Factory Non-Adjustable Link on 72-93 Models. W15. If Vehicle is Equipped with a Front Sway Bar. Lowering Brackets must be Ordered. See Dodge Accessories Section. W16. See Brake Lines Section.

<b>74.5-93 Ramcharger, Trailduster 4WD Kit With Add-A-Leafs</b>																								
2.5"	D200BAK	W1, W2, W14, W16	D240BA	2	D200S			R1120	DA20	7110	7220	8110	8220	9110	9220	H7027	H7038	N8027	N8038	B8527	B8538	M9527	M9538	4

KIT NOTES: W1. This Kit Uses Add-A-Leafs Instead of Block & U-Bolt Kit for the Rear. W2. Pitman Arm Fits 78-93 Models Only (74.5-77 Models Use Part # DA60 on 4" Lifts). W14. Adjustable Drag Link # DL10 Recommended to Replace Factory Non-Adjustable Link on 72-93 Models. W16. See Brake Lines Section.

<b>74.5-93 Ramcharger, Trailduster 4WD System With Replacement Rear Springs</b>																								
2.5"	D200BKS	W2, W10, W14, W16	D240BS	2	D200S	2	DR40S		DA20	7110	7220	8110	8220	9110	9220	H7027	H7038	N8027	N8038	B8527	B8538	M9527	M9538	4
4"	D400BKS	W2, W10, W14, W15, W16	D240BS	2	D400S	2	DR60S		DA40	7110	7220	8110	8220	9110	9220	H7017	H7068	N8017	N8068	B8517	B8568	M9517	M9568	4
6"	D600BKS	W14, W15	D680BS	2	D600S	2	DR40S		DA60	7110	7220	8110	8220	9110	9220	H7017	H7068	N8017	N8068	B8517	B8568	M9517	M9568	6
8"	D800BKS	W2, W5, W15, W16	D680BS	2	D800S	2	DR60S		DA40 + DA60	7110	7220	8110	8220	9110	9220	H7036	H7068	N8036	N8068	B8536	B8568	M9536	M9568	8

KIT NOTES: W2. Pitman Arm Fits 78-93 Models Only (74.5-77 Models Use Part # DA60 on 4" Lifts) for Steering Correction (See Steering Components Section). W5. 74.5-77 Models MUST Use # DA65 & # DL10. W10. Factory Block is Removed. W14. Adjustable Drag Link # DL10 Recommended to Replace Factory Non-Adjustable Link on 72-93 Models. W15. If Vehicle is Equipped with Front Sway Bar. Lowering Brackets must be Ordered. See Dodge Accessories Section. W16. See Brake Lines Section.

**61-74 RAMCHARGER, TRAILDUSTER 4WD NOTE: ALL SHOCKS MUST BE ORDERED SEPARATELY**

<b>61-74 Ramcharger, Trailduster 4WD Kit With Blocks &amp; U-Bolts &amp;/or Add-A-Leafs</b>																								
2.5"	D200AK		D240A	2	D200S					7110	7220	8110	8220	9110	9220	H7027	H7038	N8027	N8038	B8527	B8538	M9527	M9538	4
4"	D400AK	W7, W14, W15	D400BR	2	D400S					7110	7220	8110	8220	9110	9220	H7017	H7038	N8017	N8038	B8517	B8538	M9517	M9538	4
6"	D600AK	W7, W14, W15	D680A	2	D600S				DA60	7110	7220	8110	8220	9110	9220	H7017	H7068	N8017	N8068	B8517	B8568	M9517	M9568	6

<b>72-74 Ramcharger, Trailduster 4WD Kit With Blocks &amp; U-Bolts &amp;/or Add-A-Leafs</b>																								
8"	D800ARK	W7, W14, W15, W16	D680AR	2	D800S		R1120		DA65 + DL10	7110	7220	8110	8220	9110	9220	H7036	H7068	N8036	N8068	B8536	B8568	M9536	M9568	8

KIT NOTES: W7. Must have 3-Bolt Steering Knuckle. W14. Adjustable Drag Link # DL10 Recommended to Replace Factory Non-Adjustable Link on 72-93 Models. W15. If Vehicle is Equipped with a Front Sway Bar. Lowering Brackets must be Ordered. See Dodge Accessories Section. W16. See Brake Lines Section.

<b>61-74 Ramcharger, Trailduster 4WD Kit With Add-A-Leafs</b>																								
2.5"	D200AAK	W1, W14, W16	D240AA	2	D200S			R1120		7110	7220	8110	8220	9110	9220	H7027	H7038	N8027	N8038	B8527	B8538	M9527	M9538	4

KIT NOTES: W1. This Kit Uses Add-A-Leafs Instead of Block & U-Bolt Kit for the Rear. W14. Adjustable Drag Link # DL10 Recommended to Replace Factory Non-Adjustable Link on 72-93 Models. W16. See Brake Lines Section.

<b>72-74 Ramcharger, Trailduster 4WD System</b>																								
2.5"	D200AKS	W14, W16	D240AS	2	D200S	2	DR40S			7110	7220	8110	8220	9110	9220	H7027	H7038	N8027	N8038	B8527	B8538	M9527	M9538	4
4"	D400AKS	W7, W14, W15, W16	D240AS	2	D400S	2	DR60S		DA60	7110	7220	8110	8220	9110	9220	H7017	H7038	N8017	N8038	B8517	B8538	M9517	M9538	4
6"	D600AKS	W7, W14, W15, W16	D680AS	2	D600S	2	DR40S		DA60	7110	7220	8110	8220	9110	9220	H7017	H7068	N8017	N8068	B8517	B8568	M9517	M9568	6
8"	D800AKS	W7, W15, W16	D680AS	2	D800S	2	DR60S		DA65 + DL10	7110	7220	8110	8220	9110	9220	H7036	H7068	N8036	N8068	B8536	B8568	M9536	M9568	8

KIT NOTES: W7. Must have 3-Bolt Steering Knuckle. W14. Adjustable Drag Link # DL10 Recommended to Replace Factory Non-Adjustable Link on 72-93 Models. W15. If Vehicle is Equipped with a Front Sway Bar. Lowering Brackets must be Ordered. See Dodge Accessories Section. W16. See Brake Lines Section.

DODGE / RAM

DODGE / RAM





LIFT	Quick Kit	KIT NOTES	Component Box	Front Springs		Rear Springs		Add-A-Leafs	Steering Correction	Steering Stabilizers						HYDRO Shocks		NITRO Shocks		BLACK MAX		M95 Shocks		Labor			
				Qty	Part #	Qty	Part #			White		Black		Silver		White		Black		Silver							
				(Requires 1 Of Each)						OEM	Single	Dual	OEM	Single	Dual	OEM	Single	Dual	Front	Rear	Front	Rear	Front		Rear	Front	Rear
<b>80-96 F-150 Pickup 4WD Kit</b>		<b>Class II Brackets &amp; Radius Arms with Blocks &amp; U-Bolts</b>																									
6"	286PK-A	G8, G18, G28	286P+RA150	1	186				Included		7140	7240		8140	8240		9140	9240	H7055	H7060	N8055	N8060	B8555	B8560	M9555	M9560	8
KIT NOTES: G8. Power Steering Models Only. G18. See Brake Lines Section. G28. If Vehicle is Equipped with a Front Sway Bar. Lowering Brackets must be Ordered. See Ford Accessories Section.																											

<b>80-96 F-150 Pickup 4WD System</b>		<b>Class II Brackets &amp; Radius Arms with Replacement Rear Springs</b>																									
4"	284PKS-A	G8, G10, G18, G28	284PS+RA150	1	184	2	FR54S		Included		7140	7240		8140	8240		9140	9240	H7054	H7060	N8054	N8060	B8554	B8560	M9554	M9560	8
6"	286PKS-A	G8, G18, G28	286PS+RA150	1	186	2	FR54S		Included		7140	7240		8140	8240		9140	9240	H7055	H7060	N8055	N8060	B8555	B8560	M9555	M9560	8
KIT NOTES: G8. Power Steering Models Only. G10. The Factory Block is Removed. G18. See Brake Lines Section. G28. If Vehicle is Equipped with a Front Sway Bar. Lowering Brackets must be Ordered. See Ford Accessories Section.																											

<b>80-96 F-150 PICKUP 2WD</b>														<b>NOTE: ALL SHOCKS MUST BE ORDERED SEPARATELY.</b>													
<b>80-96 F-150 Pickup 2WD Kit</b>		<b>Standard Brackets with Blocks &amp; U-Bolts &amp;/or Add-A-Leafs</b>																									
1.5-2"	182P2K	G1, G18		1	182			R225			7140	7240		8140	8240		9140	9240	H7052	H7058	N8052	N8058	B8552	B8558	M9552	M9558	4
8"	188P2K-A	G8, G18, G28	188C+188P2	1	188			Included	Included		7140	7240		8140	8240		9140	9240	H7055	H7060	N8055	N8060	B8555	B8560	M9555	M9560	7
KIT NOTES: G1. Oversized Camber / Caster Shims are Required (See Ford Accessories Section). G8. Power Steering Models Only. G18. See Brake Lines Section. G28. If Vehicle is Equipped with a Front Sway Bar. Lowering Brackets must be Ordered. See Ford Accessories Section.																											

<b>66-79 F-150 PICKUP 4WD</b>														<b>NOTE: ALL SHOCKS MUST BE ORDERED SEPARATELY.</b>														
<b>77-79 F-150 Pickup 4WD Kit</b>		<b>With Blocks &amp; U-Bolts &amp;/or Add-A-Leafs</b>																										
1.5-2"	172PK	G11, G18		1	172			R3120			7030		7210	8030		9210	8030		9210	H7054	H7055	N8054	N8055	B8554	B8555	M9554	M9555	4
4"	174PK	G4, G13, G18		1	174			R3120	FA300		7030		7210	8030		9210	8030		9210	H7055	H7056	N8055	N8056	B8555	B8556	M9555	M9556	6
6"	176PK	G4, G15, G18, G20	176P	1	176				FA300		7030		7210	8030		9210	8030		9210	H7056	H7059	N8056	N8059	B8556	B8559	M9556	M9559	6
9"	179PK	G4, G17, G18, G20	179P	1	179			R3120	FA500		7030		7210	8030		9210	8030		9210	H7059	H7061	N8059	N8061	B8559	B8561	M9559	M9561	8
KIT NOTES: G4. Pitman Arm Only Fits 76-79 Models with Power Steering. 76-77 Models must Change Drag Link & Tie Rod Assembly to "T" Style. Order # FDL70 & # TRA70. G11. Caster Correction Required: Use # CB400 (# CB477 on 77 Models). G13. Caster Correction Required: Use # RAB27 or # CB700 (# CB777 on 77 Models). For Best Correction, Use RAB27 & CB200 (CB277 on 77 Models). G15. Caster Correction Required: Use # RAB47 or # CB700 (# CB777 for 77 Models). For Best Correction, Use RAB47 & CB200 (# CB277 for 77 Models). G17. Caster Correction Required: Use Both # RAB47 & # CB400 (# CB477 for 77 Models). G18. See Brake Lines Section. G20. Requires Brake Lines # FBL78 + # RBL76.																												

<b>77-79 F-150 Pickup 4WD System</b>		<b>With Replacement Rear Springs</b>																										
4"	174PKS	G4, G13, G18	174PS	1	174	2	FR52S		FA300		7030		7210	8030		9210	9030		9210	H7055	H7056	N8055	N8056	B8555	B8556	M9555	M9556	6
6"	176PKS	G4, G15, G18, G20	176PS	1	176	2	FR54S		FA300		7030		7210	8030		9210	9030		9210	H7056	H7059	N8056	N8059	B8556	B8559	M9556	M9559	6
9"	179PKS	G4, G9, G17, G18, G20	179PS	1	179	2	FR56S		FA500		7030		7210	8030		9210	9030		9210	H7059	H7061	N8059	N8061	B8559	B8561	M9559	M9561	8
KIT NOTES: G4. Pitman Arm Only Fits 76-79 Models with Power Steering. 76-77 Models Must Change Drag Link & Tie Rod Assembly to "T" Style. Order # FDL70 & on 77 Models). For Best Correction, Use RAB27 & CB200 (CB277 on 77 Models). G9. This Lift also Includes 2" Blocks. G13. Caster Correction Required; Use # RAB27 or # CB700 (# CB777 on 77 Models). For Best Correction, Use RAB27 & CB200 (CB277 on 77 Models). G15. Caster Correction Required; Use # RAB47 or # CB700 (# CB777 for 77 Models). For Best Correction, Use RAB47 & CB200 (# CB277 for 77 Models). G17. Caster Correction Required; Use Both # RAB47 & # CB400 (# CB477 for 77 Models). G18. See Brake Lines Section. G20. Requires Brake Lines # FBL78 + # RBL76.																												

<b>73-76 F-150 Pickup 4WD Kit</b>		<b>With Blocks &amp; U-Bolts &amp;/or Add-A-Leafs</b>																										
1.5-2"	172PK	G11, G18		1	172			R3120			7030	7110	7240	8030	8110	8240	9030	9110	9240	H7023	H7056	N8023	N8056	B8523	B8556	M9523	M9556	4
4"	174PK	G4, G18, G21		1	174			R3120	FA300		7030	7110	7240	8030	8110	8240	9030	9110	9240	H7023	H7056	N8023	N8056	B8523	B8556	M9523	M9556	6
6"	176PK	G4, G15, G18,	176P	1	176				FA300		7030	7110	7240	8030	8110	8240	9030	9110	9240	H7058	H7059	N8058	N8059	B8558	B8559	M9558	M9559	6
9"	179PK	G4, G17, G18	179P	1	179			R3120	FA500		7030	7110	7240	8030	8110	8240	9030	9110	9240	H7060	H7061	N8060	N8061	B8560	B8561	M9560	M9561	8
KIT NOTES: G4. Pitman Arm Only Fits 76-79 Models with Power Steering. 76-77 Models must Change Drag Link & Tie Rod Assembly to "T" Style. Order # FDL70 & # TRA70. G11. Caster Correction Required: Use # CB400. G15. Caster Correction Required; Use # RAB47 or # CB700 (For Best Correction, Use RAB47 & CB200). G17. Caster Correction Required; Use Both # RAB47 & # CB400. G18. See Brake Lines Section. G21. Caster Correction Required; Use # RAB27 or # CB700. (For Best Correction, Use RAB47 & CB200).																												

<b>73-76 F-150 Pickup 4WD System</b>		<b>With Replacement Rear Springs</b>																										
1.5-2"	172PKS	G11, G18	U5WWR	1	172	2	FR54S				7030	7110	7240	8030	8110	8240	9030	9110	9240	H7023	H7056	N8023	N8056	B8523	B8556	M9523	M9556	4
4"	174PKS	G4, G18, G21	174PS	1	174	2	FR52S		FA300		7030	7110	7240	8030	8110	8240	9030	9110	9240	H7023	H7056	N8023	N8056	B8523	B8556	M9523	M9556	6
6"	176PKS	G4, G15, G18	176PS	1	176	2	FR54S		FA300		7030	7110	7240	8030	8110	8240	9030	9110	9240	H7058	H7059	N8058	N8059	B8558	B8559	M9558	M9559	6
9"	179PKS	G4, G9, G17, G18	179PS	1	179	2	FR56S		FA500		7030	7110	7240	8030	8110	8240	9030	9110	9240	H7060	H7061	N8060	N8061	B8560	B8561	M9560	M9561	8
KIT NOTES: G4. Pitman Arm Only Fits 76-79 Models with Power Steering. 76-77 Models must Change Drag Link & Tie Rod Assembly to "T" Style. Order # FDL70 & # TRA70. G9. This Lift also Includes 2" Blocks. G10. The Factory Block is Removed. G11. Caster Correction Required: Use # CB400. G15. Caster Correction Required; Use # RAB47 or # CB700 (For Best Correction, Use RAB47 & CB200.) G17. Caster Correction Required; Use Both # RAB47 & # CB400. G18. See Brake Lines Section. G21. Caster Correction Required; Use # RAB27 or # CB700. (For Best Correction, Use RAB27 & CB200).																												

<b>70-72 F-100 Pickup 4WD Kit</b>		<b>With Blocks &amp; U-Bolts &amp;/or Add-A-Leafs</b>																										
2"	172EPK	G11, G18		1	172	1		R225			7030	7110	7210	8030	8110	8210	9030	9110	9210	H7023	H7056	N8023	N8056	B8523	B8556	M9523	M9556	4
4"	174EPK	G18, G21		1	174	1		R225			7030	7110	7210	8030	8110	8210	9030	9110	9210	H7023	H7056	N8023	N8056	B8523	B8556	M9523	M9556	6
6"	176PK	G15, G18	176P	1	176						7030	7110	7210	8030	8110	8210	9030	9110	9210	H7058	H7059	N8058	N8059	B8558	B8559	M9558	M9559	6
9"	179PK	G17, G18	179P	1	179	1		R225			7030	7110	7210	8030	8110	8210	9030	9110	9210	H7060	H7061	N8060	N8061	B8560	B8561	M9560	M9561	8
KIT NOTES: G11. Caster Correction Required: Use # CB400. G15. Caster Correction Required; Use # RAB47 or # CB700 (For Best Correction, Use RAB47 & CB200). G17. Caster Correction Required; Use Both # RAB47 & # CB400. G18. See Brake Lines Section. G21. Caster Correction Required; Use # RAB27 or # CB700. (For Best Correction, Use RAB27 & CB200).																												



LIFT	Quick Kit	KIT NOTES	Component Box (Requires 1 Of Each)	Front Springs		Rear Springs		Add-A-Leafs	Steering Correction (Order 1 Each)	Steering Stabilizers									HYDRO Shocks		NITRO Shocks		BLACK MAX		M95 Shocks		Labor Hours
				Qty	Part #	Qty	Part #			White			Black			Silver			White		Black		Silver				
	OEM			Single	Dual	OEM	Single			Dual	OEM	Single	Dual	OEM	Single	Dual	Front	Rear	Front	Rear	Front	Rear	Front	Rear			
<b>66-69 F-100 Pickup 4WD Kit</b> With Blocks & U-Bolts &/or Add-A-Leafs																											
1.5"-2"	172EPK	G11, G18		1	172			R225		7030	7110	7210	8030	8110	8210	9030	9110	9210	H7023	H7058	N8023	N8058	B8523	B8558	M9523	M9558	4
4"	174EPK	G18, G21		1	174			R225		7030	7110	7210	8030	8110	8210	9030	9110	9210	H7023	H7058	N8023	N8058	B8523	B8558	M9523	M9558	6
6"	176PK	G15, G18	176P	1	176					7030	7110	7210	8030	8110	8210	9030	9110	9210	H7058	H7041	N8058	N8041	B8558	B8541	M9558	M9541	6
9"	179PK	G17, G18	179P	1	179			R225		7030	7110	7210	8030	8110	8210	9030	9110	9210	H7060	H7060	N8060	N8060	B8560	B8560	M9560	M9560	8

KIT NOTES: G11. Caster Correction Required; Use # CB400. G15. Caster Correction Required; Use # RAB47 or # CB700 (For Best Correction, Use RAB47 & CB200). G17. Caster Correction Required; Use Both # RAB47 & # CB400. G18. See Brake Lines Section. G21. Caster Correction Required; Use # RAB27 or # CB700. (For Best Correction, Use RAB27 & CB200).

**80-96 BRONCO 4WD** NOTE: ALL SHOCKS MUST BE ORDERED SEPARATELY.

<b>80-96 Bronco 4WD Kit</b> With Blocks & U-Bolts &/or Add-A-Leafs																											
1.5"-2"	182K	G1, G18		1	182			R3120			7140	7240		8140	8240		9140	9240	H7052	H7058	N8052	N8058	B8552	B8558	M9552	M9558	4
4"	184BK	G8, G18, G28	184B	1	184				FA400		7140	7240		8140	8240		9140	9240	H7054	H7058	N8054	N8058	B8554	B8558	M9554	M9558	6
6"	186BK	G8, G18, G28	186B	1	186				FA400		7140	7240		8140	8240		9140	9240	H7055	H7060	N8055	N8060	B8555	B8060	M9555	M9560	6
8"	188BK-A	G8, G18	188C+188B	1	188				Included		7140	7240		8140	8240		9140	9240	H7055	H7060	N8055	N8060	B8555	B8560	M9555	M9560	7

KIT NOTES: G1. Oversized Camber / Caster Shims are Required (See Ford Accessories Section). G8. Power Steering Models Only. G18. See Brake Lines Section. G28. If Vehicle is Equipped with a Front Sway Bar. Lowering Brackets must be Ordered. See Ford Accessories Section.

<b>80-96 Bronco 4WD System</b> With Replacement Rear Springs																											
1.5"-2"	182BKS	G1, G18	182BS	1	182	2	FR51S				7140	7240		8140	8240		9140	9240	H7052	H7058	N8052	N8058	B8552	B8558	M9552	M9558	4
4"	184BKS	G8, G18, G28	184BS	1	184	2	FR52S		FA400		7140	7240		8140	8240		9140	9240	H7054	H7058	N8054	N8058	B8554	B8558	M9554	M9558	6
6"	186BKS	G8, G18, G28	186BS	1	186	2	FR54S		FA400		7140	7240		8140	8240		9140	9240	H7055	H7060	N8055	N8060	B8555	B8560	M9555	M9560	6
8"	188BKS-A	G8, G18	188C+188BS	1	188	2	FR56S		Included		7140	7240		8140	8240		9140	9240	H7055	H7060	N8055	N8060	B8555	B8560	M9555	M9560	7

KIT NOTES: G1. Oversized Camber / Caster Shims are Required (See Ford Accessories Section). G8. Power Steering Models Only. G18. See Brake Lines Section. G28. If Vehicle is Equipped with a Front Sway Bar. Lowering Brackets must be Ordered. See Ford Accessories Section.

<b>80-96 Bronco 4WD Kit</b> Class II Brackets & Radius Arms with Blocks & U-Bolts																											
6"	286BK-A	G8, G18, G28	286B+RA150	1	186				Included		7140	7240		8140	8240		9140	9240	H7055	H7060	N8055	N8060	B8555	B8560	M9555	M9560	8

KIT NOTES: G8. Power Steering Models Only. G18. See Brake Lines Section. G28. If Vehicle is Equipped with a Front Sway Bar. Lowering Brackets must be Ordered. See Ford Accessories Section.

<b>80-96 Bronco 4WD System</b> Class II Brackets & Radius Arms with Replacement Rear Springs																											
4"	284BKS-A	G8, G18, G28	284BS+RA150	1	184	2	FR52S		Included		7140	7240		8140	8240		9140	9240	H7054	H7058	N8054	N8058	B8554	B8558	M9554	M9558	8
6"	286BKS-A	G8, G18, G28	286BS+RA150	1	186	2	FR54S		Included		7140	7240		8140	8240		9140	9240	H7055	H7060	N8055	N8060	B8555	B8560	M9555	M9560	8

KIT NOTES: G8. Power Steering Models Only. G18. See Brake Lines Section. G28. If Vehicle is Equipped with a Front Sway Bar. Lowering Brackets must be Ordered. See Ford Accessories Section.

**67-79 BRONCO 4WD** NOTE: ALL SHOCKS MUST BE ORDERED SEPARATELY.

<b>78-79 Bronco 4WD Kit</b> With Blocks & U-Bolts &/or Add-A-Leafs																											
1.5"-2"	172BK	G11, G18		1	172			R3120		7030		7210	8030		8210	9030		9210	H7055 <sup>(A)</sup>	H7023	N8055 <sup>(A)</sup>	N8023	B8555 <sup>(A)</sup>	B8523	M9555 <sup>(A)</sup>	M9523	4
4"	174BK	G8, G18, G21		1	174			R300	FA300	7030		7210	8030		8210	9030		9210	H7056 <sup>(A)</sup>	H7058	N8056 <sup>(A)</sup>	N8058	B8556 <sup>(A)</sup>	B8558	M9556 <sup>(A)</sup>	M9558	6
6"	176BK	G8, G15, G18, G20	176B	1	176				FA300	7030		7210	8030		8210	9030		9210	H7059 <sup>(A)</sup>	H7058	N8059 <sup>(A)</sup>	N8058	B8559 <sup>(A)</sup>	B8558	M9559 <sup>(A)</sup>	M9558	6
9"	179BK	G8, G17, G18, G20	179B	1	179			R300	FA500	7030		7210	8030		8210	9030		9210	H7061 <sup>(A)</sup>	H7060	N8061 <sup>(A)</sup>	N8060	B8561 <sup>(A)</sup>	B8560	M9561 <sup>(A)</sup>	M9560	8

KIT NOTES: G8. Power Steering Models Only. G11. Caster Correction Required; Use # CB400. G15. Caster Correction Required; Use # RAB47 or # CB700 (For Best Correction, Use RAB47 & CB200). G17. Caster Correction Required; Use Both # RAB47 & # CB400. G18. See Brake Lines Section. G20. Requires Brake Lines # FBL78 + # RBL76. G21. Caster Correction Required; Use # RAB27 or #CB700. (For Best Correction, Use RAB27 & CB200).

(A). Ahead Of Axle. (B). Behind Axle.

<b>78-79 Bronco 4WD System</b> With Replacement Rear Springs																											
4"	174BKS	G8, G18, G21	174BS	1	174	2	FR52S		FA300	7030		7210	8030		8210	9030		9210	H7056 <sup>(A)</sup>	H7058	N8056 <sup>(A)</sup>	N8058	B8556 <sup>(A)</sup>	B8558	M9556 <sup>(A)</sup>	M9558	6
6"	176BKS	G8, G15, G18, G20	176BS	1	176	2	FR54S		FA300	7030		7210	8030		8210	9030		9210	H7059 <sup>(A)</sup>	H7058	N8059 <sup>(A)</sup>	N8058	B8559 <sup>(A)</sup>	B8558	M9559 <sup>(A)</sup>	M9558	6
9"	179BKS	G8, G17, G18, G20	179BS	1	179	2	FR56S		FA500	7030		7210	8030		8210	9030		9210	H7061 <sup>(A)</sup>	H7060	N8061 <sup>(A)</sup>	N8060	B8561 <sup>(A)</sup>	B8560	M9561 <sup>(A)</sup>	M9560	8

KIT NOTES: G8. Power Steering Models Only. G15. Caster Correction Required; Use # RAB47 or # CB700 (For Best Correction, Use RAB47 & CB200). G17. Caster Correction Required; Use Both # RAB47 & # CB400. G18. See Brake Lines Section. G20. Requires Brake Lines # FBL78 # RBL76. G21. Caster Correction Required; Use # RAB27 or # CB700. (For Best Correction, Use RAB27 & CB200).

(A). Ahead Of Axle. (B). Behind Axle.

<b>67-77 Bronco 4WD Kit</b> With Blocks & U-Bolts &/or Add-A-Leafs																											
3"	172EBK	G12, G18		1	172			R225		7030			8030			9030			H7055	H7023	N8055	N8023	B8555	B8523	M9555	M9523	4
5"	174EBK	G5, G14, G18	174EB	1	174				FA307	7030			8030			9030			H7055	H7058	N8055	N8058	B8555	B8558	M9555	M9558	6

KIT NOTES: G5. Pitman Arm Fits Manual & Power Steering. 76-77 Models Must Change Drag Link & Tie Rod Assembly to "T" Style. Order # FDL67 & # TRA60. G12. Caster Correction Required; Use # CB400 (# CB477 on 76-77 Models). G14. Caster Correction Required; Use # RAB40 or # CB700 (# CB777 on 76-77 Models). G18. See Brake Lines Section.

FORD

FORD



LIFT	Quick Kit Reference	KIT NOTES	Component Box (Requires 1 Of Each)	Front Springs		Rear Springs		Add-A-Leafs	Steering Correction (Order 1 Each)	Steering Stabilizers						HYDRO Shocks		NITRO Shocks		BLACK MAX		M95 Shocks		Labor Hours								
				Qty	Part #	Qty	Part #			White			Black			Silver			White		Black		Silver									
										OEM	Single	Dual	OEM	Single	Dual	OEM	Single	Dual	Front	Rear	Front	Rear	Front		Rear	Front	Rear					
<b>CLASS II - ADJUSTABLE 4-LINKS</b>																																
<b>17-18 F-250 Super Duty 4WD Class II Kit (Diesel Engine) Variable Rate Front Coil Springs with Rear Blocks &amp; U-Bolts</b>																																
4"	F174524K	G42	F17451 + F58484LU	1	F545V										7254			8254			9254	H7092	H7068	N8092	N8068	B8592	B8568	M9592	M9568	8		
6"	F176524K	G43	F17651 + F58484LU	1	F565V				Included						7254			8254			9254	H7093	H7068	N8093	N8068	B8593	B8568	M9593	M9568	8		
8.5"	F17852K	G43	F17852 + F58484LU	1	F585V			R3815	Included						7254			8254			9254	H7094	H7089	N8094	N8089	B8594	B8589	M9594	M9589	8		
<b>17-18 F-250 Super Duty 4WD Class II System (Diesel Engine) Variable Rate Front Coil Springs with Rear Leaf Springs</b>																																
4"	F174524KS	G42	F17451S + F58484LU	1	F545V	2	FR173S								7254			8254			9254	H7092	H7068	N8092	N8068	B8592	B8568	M9592	M9568	8		
6"	F176524KS	G43	F17651S + F58484LU	1	F565V	2	FR175S		Included						7254			8254			9254	H7093	H7068	N8093	N8068	B8593	B8568	M9593	M9568	8		
8.5"	F17852KS	G43	F17852S + F58484LU	1	F585V	2	FR177S		Included						7254			8254			9254	H7094	H7089	N8094	N8089	B8594	B8589	M9594	M9589	8		
<b>17-18 F-250 Super Duty 4WD Class II Kit (Gas Engine) Softride® Front Coil Springs with Rear Blocks &amp; U-Bolts</b>																																
4"	F174024K	G42	F17451 + F58484LU	1	F540										7254			8254			9254	H7092	H7068	N8092	N8068	B8592	B8568	M9592	M9568	8		
6"	F176024K	G43	F17651 + F58484LU	1	F560				Included						7254			8254			9254	H7093	H7068	N8093	N8068	B8593	B8568	M9593	M9568	8		
8.5"	F17802K	G43	F17852 + F58484LU	1	F565V			R3815	Included						7254			8254			9254	H7094	H7089	N8094	N8089	B8594	B8589	M9594	M9589	10		
<b>17-18 F-250 Super Duty 4WD Class II System (Gas Engine) Softride® Front Coil Springs with Rear Leaf Springs</b>																																
4"	F174024KS	G42	F17451S + F58484LU	1	F540	2	FR173S								7254			8254			9254	H7092	H7068	N8092	N8068	B8592	B8568	M9592	M9568	8		
6"	F176024KS	G43	F17651S + F58484LU	1	F560	2	FR175S		Included						7254			8254			9254	H7093	H7068	N8093	N8068	B8593	B8568	M9593	M9568	8		
8.5"	F17802KS	G43	F17852S + F58484LU	1	F565V	2	FR177S		Included						7254			8254			9254	H7094	H7089	N8094	N8089	B8594	B8589	M9594	M9589	10		
<b>LEDUC SERIES COIL-OVER KITS</b>																																
<b>17-18 F-250 Super Duty 4WD Coil-Over Kit (Diesel or Gas) Front LeDuc Series Coil-Overs with Rear Blocks &amp; U-Bolts</b>																																
6"	F1761LSK	G43	F76FLSB + F17651	1	F768FLS				Included						7254			8254			9254	H7068		N8068		B8568		M9568	6			
<b>17-18 F-250 Super Duty 4WD Coil-Over System (Diesel or Gas) Front LeDuc Series Coil-Overs with Rear Leaf Springs</b>																																
6"	F1761LSKS	G43	F76FLSB + F17651S	1	F768FLS	2	FR175S		Included						7254			8254			9254	H7068		N8068		B8568		M9568	6			
<b>CLASS II - LEDUC SERIES COIL-OVER KITS WITH ADJUSTABLE 4-LINKS</b>																																
<b>17-18 F-250 Super Duty 4WD Class II Kit (Diesel or Gas) Front LeDuc Series Coil-Overs with Rear Blocks &amp; U-Bolts</b>																																
6"	F17624LSK	G43	F76FLSB + F17651 + F58484LU	1	F768FLS				Included						7254			8254			9254	H7068		N8068		B8568		M9568	9			
8.5"	F1782LSK	G43	F78FLSB + F17852 + F58484LU	1	F768FLS			R3815	Included						7254			8254			9254	H7089		N8089		B8589		M9589	10			
<b>17-18 F-250 Super Duty 4WD Class II System (Diesel or Gas) Front LeDuc Series Coil-Overs with Rear Leaf Springs</b>																																
6"	F17624LSKS	G43	F76FLSB + F17651S + F58484LU	1	F768FLS	2	FR175S		Included						7254			8254			9254	H7068		N8068		B8568		M9568	9			
8.5"	F1782LSKS	G43	F78FLSB + F17852S + F58484LU	1	F768FLS	2	FR177S		Included						7254			8254			9254	H7089		N8089		B8589		M9589	10			
KIT NOTES: G42. Lift is specifically designed to not require a drop pitman arm. G43. If front drive shaft vibration occurs, front drive shaft modification is required or order a new front drive shaft Part # F17685DS.																																
<b>11-16 F-250 SUPER DUTY 4WD DIESEL ENGINE</b>												<b>NOTE: ALL SHOCKS MUST BE ORDERED SEPARATELY.</b>																				
<b>11-16 F-250 Super Duty 4WD Kit Front Metal Spacers</b>																																
1"	F51MS		F51MS												7054			8054			9054	H7091	H7060	N8091	N8060	B8591	B8560	M9591	M9560	2		
<b>11-16 F-250 Super Duty 4WD Kit Front Metal Spacers with Front Track Bar Bracket</b>																																
2.5"	F528MSP		F528MSP												7054			8054			9054	H7091	H7060	N8091	N8060	B8591	B8560	M9591	M9560	3		
<b>11-16 F-250 Super Duty 4WD Kit Front Metal Spacers with Rear Add-A-Leafs</b>																																
2.5"	F82MK	G33	F52MS					R3815							7054			8054			9054	H7091	H7060	N8091	N8060	B8591	B8560	M9591	M9560	4		
KIT NOTES: G33. Optional Track Bar Relocation Bracket may be Required. Part # TB1120.																																
<b>11-16 F-250 Super Duty (Diesel Engine) 4WD Kit Diesel Engines with Add-A-Leafs</b>																																
2"	F825K	G33		1	F525V			R3815							7054			8054			9054	H7091	H7060	N8091	N8060	B8591	B8560	M9591	M9560	4		
KIT NOTES: G33. Optional Track Bar Relocation Bracket may be Required. Part # TB1120.																																
<b>11-16 F-250 Super Duty (Diesel Engine) 4WD Kit Diesel Engines with Blocks &amp; U-Bolts</b>																																
4"	F11451K	G31, G32, G36	F11451	1	F545V				FA450						7054	Bkt. Incl.	7254	8054	Bkt. Incl.	8254	9054	Bkt. Incl.	9254	H7092	H7060	N8092	N8060	B8592	B8560	M9592	M9560	6
6"	F11651K	G31, G32, G36	F11651	1	F565V				FA450						7054	Bkt. Incl.	7254	8054	Bkt. Incl.	8254	9054	Bkt. Incl.	9254	H7093	H7079	N8093	N8079	B8593	B8579	M9593	M9579	6
<b>11-16 F-250 Super Duty (Diesel Engine) 4WD System Diesel Engines with Rear Springs</b>																																
4"	F11451KS	G31, G32, G36	F11451S	1	F545V	2	FR84S		FA450						7054	Bkt. Incl.	7254	8054	Bkt. Incl.	8254	9054	Bkt. Incl.	9254	H7092	H7060	N8092	N8060	B8592	B8560	M9592	M9560	6
6"	F11651KS	G31, G32, G36	F11651S	1	F565V	2	FR86S		FA450						7054	Bkt. Incl.	7254	8054	Bkt. Incl.	8254	9054	Bkt. Incl.	9254	H7093	H7079	N8093	N8079	B8593	B8579	M9593	M9579	6
KIT NOTES: Upgrade Available for 4 & 6" Kit. Part # F58484LU. Radius Arm Conversion to Upper & Lower Control Arms. G31. Lift is Designed to Level Models with Factory 1 7/8" Rear Blocks. Models with Otonal Factory 3 7/8" Rear Blocks will have a Higher Rake Angle in the Rear. G32. Lift Heights will Vary Depending on Factory Pckage Options. G36. Model with Rear Sway Bar must Order Extended Rear Sway Bar End Liks. 4" Lifts Order Part # SBE404, 6" Lifts Order Part # SBE405, 8.5" Lifts Order Part # SBE406.																																

FORD

FORD

LIFT	Quick Kit Reference	KIT NOTES	Component Box (Requires 1 Of Each)	Front Springs		Rear Springs		Add-A-Leafs	Steering Correction (Order 1 Each)	Steering Stabilizers						HYDRO Shocks		NITRO Shocks		BLACK MAX		M95 Shocks		Labor Hours			
				Qty	Part #	Qty	Part #			White		Black		Silver		White		White		Black		Silver					
										OEM	Single	Dual	OEM	Single	Dual	OEM	Single	Dual	Front	Rear	Front	Rear	Front		Rear	Front	Rear
<b>CLASS II - ADJUSTABLE 4-LINKS</b>																											
<b>11-16 F-250 Super Duty (Diesel Engine) 4WD Class II Kit Diesel Engines with Blocks &amp; U-Bolts</b>																											
4"	F114524K	G31, G32, G36	F11451 + F58484LU	1	F545V				FA450	7054	Bkt. Incl.	7254	8054	Bkt. Incl.	8254	9054	Bkt. Incl.	9254	H7092	H7060	N8092	N8060	B8592	B8560	M9592	M9560	6
6"	F116524K	G31, G32, G36	F11651 + F58484LU	1	F565V				FA450	7054	Bkt. Incl.	7254	8054	Bkt. Incl.	8254	9054	Bkt. Incl.	9254	H7093	H7079	N8093	N8079	B8593	B8579	M9593	M9579	6
<b>11-16 F-250 Super Duty (Diesel Engine) 4WD Class II System Diesel Engines with Rear Springs</b>																											
4"	F114524KS	G31, G32, G36	F11451S + F58484LU	1	F545V	2	FR84S		FA450	7054	Bkt. Incl.	7254	8054	Bkt. Incl.	8254	9054	Bkt. Incl.	9254	H7092	H7060	N8092	N8060	B8592	B8560	M9592	M9560	6
6"	F116524KS	G31, G32, G36	F11651S + F58484LU	1	F565V	2	FR86S		FA450	7054	Bkt. Incl.	7254	8054	Bkt. Incl.	8254	9054	Bkt. Incl.	9254	H7093	H7079	N8093	N8079	B8593	B8579	M9593	M9579	6
<b>11-16 F-250 Super Duty (Diesel Engine) 4WD Class II Kit Diesel Engines with Blocks &amp; U-Bolts</b>																											
8.5"	F11852K	G31, G32, G36	F11852 + F58484LU	1	F585V			R3815	FA450	7054	Bkt. Incl.	7254	8054	Bkt. Incl.	8254	9054	Bkt. Incl.	9254	H7094	H7099	N8094	N8099	B8594	B8599	M9594	M9599	12
<b>11-16 F-250 Super Duty (Diesel Engine) 4WD Class II System Diesel Engines with Rear Springs</b>																											
8.5"	F11852KS	G31, G32, G36	F11852S + F58484LU	1	F585V	2	FR88S		FA450	7054	Bkt. Incl.	7254	8054	Bkt. Incl.	8254	9054	Bkt. Incl.	9254	H7094	H7099	N8094	N8099	B8594	B8599	M9594	M9599	12
KIT NOTES: 8.5" Lifts - Front & Rear Driveline Modifications Necessary. Call for Details. * Recommend CV Joint at Transfer Case for some Models. G31. Lift is Designed to Level Models with Factory 1 7/8" Rear Blocks. Models with Optional Factory 3 7/8" Rear Blocks will have a Higher Rake Angle in the Rear. G32. Lift Heights will Vary Depending on Factory Package Options. G36. Model with Rear Sway Bar must Order Extended Rear Sway Bar End Links. 4" Lifts Order Part # SBE404, 6" Lifts Order Part # SBE405, 8.5" Lifts Order Part # SBE406.																											
<b>11-16 F-250 SUPER DUTY 4WD GAS ENGINE</b>										<b>NOTE: ALL SHOCKS MUST BE ORDERED SEPARATELY.</b>																	
<b>11-16 F-250 Super Duty 4WD Kit Front Metal Spacers</b>																											
1"	F51MS		F51MS							7054			8054			9054			H7091	H7060	N8091	N8060	B8591	B8560	M9591	M9560	2
<b>11-16 F-250 Super Duty 4WD Kit Front Metal Spacers With Rear Add-A-Leafs</b>																											
2.5"	F82MK	G33	F52MS					R3815		7054			8054			9054			H7091	H7060	N8091	N8060	B8591	B8560	M9591	M9560	4
<b>11-16 F-250 Super Duty (Gas Engine) 4WD Kit Gas Engines with Add-A-Leafs</b>																											
2"	F820K	G33		1	F520			R3815		7054			8054			9054			H7091	H7060	N8091	N8060	B8591	B8560	M9591	M9560	4
KIT NOTES: G33. Optional Track Bar Relocation Bracket may be Required. Part # TB1120.																											
<b>11-16 F-250 Super Duty (Gas Engine) 4WD Kit Gas Engines with Blocks &amp; U-Bolts</b>																											
4"	F11401K	G31, G32, G36	F11451	1	F540				FA450	7054	Bkt. Incl.	7254	8054	Bkt. Incl.	8254	9054	Bkt. Incl.	9254	H7092	H7060	N8092	N8060	B8592	B8560	M9592	M9560	6
6"	F11601K	G31, G32, G36	F11651	1	F560				FA450	7054	Bkt. Incl.	7254	8054	Bkt. Incl.	8254	9054	Bkt. Incl.	9254	H7093	H7079	N8093	N8079	B8593	B8579	M9593	M9579	6
<b>11-16 F-250 Super Duty (Gas Engine) 4WD System Gas Engines with Rear Springs</b>																											
4"	F11401KS	G31, G32, G36	F11451S	1	F540	2	FR84S		FA450	7054	Bkt. Incl.	7254	8054	Bkt. Incl.	8254	9054	Bkt. Incl.	9254	H7092	H7060	N8092	N8060	B8592	B8560	M9592	M9560	6
6"	F11601KS	G31, G32, G36	F11651S	1	F560	2	FR86S		FA450	7054	Bkt. Incl.	7254	8054	Bkt. Incl.	8254	9054	Bkt. Incl.	9254	H7093	H7079	N8093	N8079	B8593	B8579	M9593	M9579	6
KIT NOTES: Upgrade Available for 4 & 6" Kit. Part # F58484LU. Radius Arm Conversion to Upper & Lower Control Arms. G31. Lift is Designed to Level Models with Factory 1 7/8" Rear Blocks. Models with Optional Factory 3 7/8" Rear Blocks will have a Higher Rake Angle in the Rear. G32. Lift Heights will Vary Depending on Factory Package Options. G36. Model with Rear Sway Bar must Order Extended Rear Sway Bar End Links. 4" Lifts Order Part # SBE404, 6" Lifts Order Part # SBE405, 8.5" Lifts Order Part # SBE406.																											
<b>CLASS II - ADJUSTABLE 4-LINKS</b>																											
<b>11-16 F-250 Super Duty (Gas Engine) 4WD Class II Kit Class II Gas Engines with Blocks &amp; U-Bolts</b>																											
4"	F114024K	G31, G32, G36	F11451 + F58484LU	1	F540				FA450	7054	Bkt. Incl.	7254	8054	Bkt. Incl.	8254	9054	Bkt. Incl.	9254	H7092	H7060	N8092	N8060	B8592	B8560	M9592	M9560	6
6"	F116024K	G31, G32, G36	F11651 + F58484LU	1	F560				FA450	7054	Bkt. Incl.	7254	8054	Bkt. Incl.	8254	9054	Bkt. Incl.	9254	H7093	H7079	N8093	N8079	B8593	B8579	M9593	M9579	6
<b>11-16 F-250 Super Duty (Gas Engine) 4WD System Class II Gas Engines with Rear Springs</b>																											
4"	F114024KS	G31, G32, G36	F11451S + F58484LU	1	F540	2	FR84S		FA450	7054	Bkt. Incl.	7254	8054	Bkt. Incl.	8254	9054	Bkt. Incl.	9254	H7092	H7060	N8092	N8060	B8592	B8560	M9592	M9560	6
6"	F116024KS	G31, G32, G36	F11651S + F58484LU	1	F560	2	FR86S		FA450	7054	Bkt. Incl.	7254	8054	Bkt. Incl.	8254	9054	Bkt. Incl.	9254	H7093	H7079	N8093	N8079	B8593	B8579	M9593	M9579	6
<b>11-16 F-250 Super Duty (Gas Engine) 4WD Class II Kit Class II Gas Engines with Blocks &amp; U-Bolts</b>																											
8.5"	F11802K	G31, G32, G36	F11852 + F58484LU	1	F565V			R3815	FA450	7054	Bkt. Incl.	7254	8054	Bkt. Incl.	8254	9054	Bkt. Incl.	9254	H7094	H7099	N8094	N8099	B8594	B8599	M9594	M9599	12
<b>11-16 F-250 Super Duty (Gas Engine) 4WD System Class II Gas Engines with Rear Springs</b>																											
8.5"	F11802KS	G31, G32, G36	F11852S + F58484LU	1	F565V	2	FR88S		FA450	7054	Bkt. Incl.	7254	8054	Bkt. Incl.	8254	9054	Bkt. Incl.	9254	H7094	H7099	N8094	N8099	B8594	B8599	M9594	M9599	12
KIT NOTES: 8.5" Lifts - Front & Rear Driveline Modifications Necessary. Call for Details. * Recommend CV Joint at Transfer Case for some Models. G31. Lift is Designed to Level Models with Factory 1 7/8" Rear Blocks. Models with Optional Factory 3 7/8" Rear Blocks will have a Higher Rake Angle in the Rear. G32. Lift Heights will Vary Depending on Factory Package Options. G36. Model with Rear Sway Bar must Order Extended Rear Sway Bar End Links. 4" Lifts Order Part # SBE404, 6" Lifts Order Part # SBE405, 8.5" Lifts Order Part # SBE406.																											
<b>08-10 F-250 SUPER DUTY 4WD DIESEL ENGINE</b>										<b>NOTE: ALL SHOCKS MUST BE ORDERED SEPARATELY.</b>																	
<b>08-10 F-250 Super Duty 4WD Kit Front Metal Spacers</b>																											
1"	F51MS		F51MS							7054			8054			9054			H7091	H7060	N8091	N8060	B8591	B8560	M9591	M9560	2
<b>08-10 F-250 Super Duty 4WD Kit Front Metal Spacers with Front Track Bar Bracket</b>																											
2.5"	F528MSP		F528MSP							7054			8054			9054			H7091	H7060	N8091	N8060	B8591	B8560	M9591	M9560	3
<b>08-10 F-250 Super Duty 4WD Kit Front Metal Spacers With Rear Add-A-Leafs</b>																											
2.5"	F82MK	G33	F52MS					R3815		7054			8054			9054			H7091	H7060	N8091	N8060	B8591	B8560	M9591	M9560	4
KIT NOTES: G33. Optional Track Bar Relocation Bracket may be Required. Part # TB1120.																											
<b>08-10 F-250 Super Duty (Diesel Engine) 4WD Kit Diesel Engines with Add-A-Leafs</b>																											
2"	F825K	G33		1	F525V			R3815		7054			8054			9054			H7091	H7060	N8091	N8060	B8591	B8560	M9591	M9560	4
KIT NOTES: G33. Optional Track Bar Relocation Bracket may be Required. Part # TB1120.																											

FORD

FORD

LIFT	Quick Kit Reference	KIT NOTES	Component Box		Front Springs		Rear Springs		Add-A-Leafs	Steering Correction (Order 1 Each)	Steering Stabilizers						HYDRO Shocks		NITRO Shocks		BLACK MAX		M95 Shocks		Labor Hours			
			(Requires 1 Of Each)		Qty	Part #	Qty	Part #			White		Black		Silver		White		White		Black		Silver					
			OEM	Single	Dual	OEM	Single	Dual			OEM	Single	Dual	OEM	Single	Dual	Front	Rear	Front	Rear	Front	Rear	Front	Rear				
<b>08-10 F-250 Super Duty (Diesel Engine) 4WD Kit Diesel Engines with Blocks &amp; U-Bolts</b>																												
4"	F8451K	G31, G32, G36, G37	F8451	1	F545V					FA450	7054	Included	7254	8054		8254	9054		9254	H7092	H7060	N8092	N8060	B8592	B8560	M9592	M9560	6
6"	F8651K	G31, G32, G36, G37	F8651	1	F565V					FA450	7054	Included	7254	8054		8254	9054		9254	H7093	H7079	N8093	N8079	B8593	B8579	M9593	M9579	6

<b>08-10 F-250 Super Duty (Diesel Engine) 4WD System Diesel Engines with Rear Springs</b>																												
4"	F8451KS	G31, G32, G36, G37	F8451S	1	F545V	2	FR84S			FA450	7054	Included	7254	8054		8254	9054		9254	H7092	H7060	N8092	N8060	B8592	B8560	M9592	M9560	6
6"	F8651KS	G31, G32, G36, G37	F8651S	1	F565V	2	FR86S			FA450	7054	Included	7254	8054		8254	9054		9254	H7093	H7079	N8093	N8079	B8593	B8579	M9593	M9579	6

KIT NOTES: Upgrade Available for 4 & 6" Kit. Part # F58484LU. Radius Arm Conversion to Upper & Lower Control Arms. G31. Lift is Designed to Level Models with Factory 1 7/8" Rear Blocks. Models with Optional Factory 3 7/8" Rear Blocks will have a Higher Rake Angle in the Rear. G32. Lift Heights will Vary Depending on Factory Package Options. G36. Model with Rear Sway Bar must Order Extended Rear Sway Bar End Links. 4" Lifts Order Part # SBE404, 6" Lifts Order Part # SBE405. G37. Models Equipped with a Sterling Rear Axle will Need Wider Rear U-Bolts. 4" Lifts Order Part # U9B16R, 4" Systems Order Part # U9B12R, 6" Kits Order Part # U9B18R, 6" Systems Order Part # U9B12R.

**CLASS II - ADJUSTABLE 4-LINKS**

<b>08-10 F-250 Super Duty (Diesel Engine) 4WD Class II Kit Diesel Engines with Blocks &amp; U-Bolts</b>																												
4"	F84524K	G31, G32, G36, G37	F8451 + F58484LU	1	F545V					FA450	7054	Included	7254	8054		8254	9054		9254	H7092	H7060	N8092	N8060	B8592	B8560	M9592	M9560	6
6"	F86524K	G31, G32, G36, G37	F8651 + F58484LU	1	F565V					FA450	7054	Included	7254	8054		8254	9054		9254	H7093	H7079	N8093	N8079	B8593	B8579	M9593	M9579	6

<b>08-10 F-250 Super Duty (Diesel Engine) 4WD Class II System Diesel Engines with Rear Springs</b>																												
4"	F84524KS	G31, G32, G36, G37	F8451S + F58484LU	1	F545V	2	FR84S			FA450	7054	Included	7254	8054		8254	9054		9254	H7092	H7060	N8092	N8060	B8092	B8560	M9592	M9560	6
6"	F86524KS	G31, G32, G36, G37	F8651S + F58484LU	1	F565V	2	FR86S			FA450	7054	Included	7254	8054		8254	9054		9254	H7093	H7079	N8093	N8079	B8593	B8579	M9593	M9579	6

<b>08-10 F-250 Super Duty (Diesel Engine) 4WD Class II Kit Diesel Engines with Blocks &amp; U-Bolts</b>																												
8.5"	F8852K	G31, G32, G36, G38	F8852 + F58484LU	1	F585V			R3815		FA450	7054	Included	7254	8054		8254	9054		9254	H7094	H7099	N8094	N8099	B8594	B8599	M9594	M9599	12

<b>08-10 F-250 Super Duty (Diesel Engine) 4WD Class II System Diesel Engines with Rear Springs</b>																												
8.5"	F8852KS	G31, G32, G36	F8852S + F58484LU	1	F585V	2	FR88S			FA450	7054	Included	7254	8054		8254	9054		9254	H7094	H7099	N8094	N8099	B8594	B8599	M9594	M9599	12

KIT NOTES: 8.5" Lifts - Front & Rear Driveline Modifications Necessary. Call for Details. \* Recommend CV Joint at Transfer Case for some Models. G31. Lift is Designed to Level Models with Factory 1 7/8" Rear Blocks. Models with Optional Factory 3 7/8" Rear Blocks will have a Higher Rake Angle in the Rear. G32. Lift Heights will Vary Depending on Factory Package Options. G36. Model with Rear Sway Bar must Order Extended Rear Sway Bar End Links. 4" Lifts Order Part # SBE404, 6" Lifts Order Part # SBE405. G37. Models Equipped with a Sterling Rear Axle will Need Wider Rear U-Bolts. 4" Lifts Order Part # U9B16R, 4" Systems Order Part # U9B12R, 6" Kits Order Part # U9B18R, 6" Systems Order Part # U9B12R. G38. Model with Rear Sway Bar must Order Extended Rear Sway Bar End Links. 8.5" Lifts Order Part # SBE406.

**08-10 F-250 SUPER DUTY 4WD GAS ENGINE NOTE: ALL SHOCKS MUST BE ORDERED SEPARATELY.**

<b>08-10 F-250 Super Duty 4WD Kit Front Metal Spacers</b>																														
1"	F51MS		F51MS								7054								9054			H7091	H7060	N8091	N8060	B8591	B8560	M9591	M9560	2

<b>08-10 F-250 Super Duty 4WD Kit Front Metal Spacers with Front Track Bar Bracket</b>																														
2.5"	F528MSP		F528MSP																			H7091	H7060	N8091	N8060	B8591	B8560	M9591	M9560	3

<b>08-10 F-250 Super Duty 4WD Kit Front Metal Spacers with Rear Add-A-Leafs</b>																														
2.5"	F82MK	G33	F52MS					R3815			7054								9054			H7091	H7060	N8091	N8060	B8591	B8560	M9591	M9560	4

KIT NOTES: G33. Optional Track Bar Relocation Bracket may be Required. Part # TB1120.

<b>08-10 F-250 Super Duty (Gas Engine) 4WD Kit Gas Engines with Add-A-Leafs</b>																														
2"	F820K	G33		1	F520			R3815			7054								9054			H7091	H7060	N8091	N8060	B8591	B8560	M9591	M9560	4

KIT NOTES: G33. Optional Track Bar Relocation Bracket may be Required. Part # TB1120.

<b>08-10 F-250 Super Duty (Gas Engine) 4WD Kit Gas Engines with Blocks &amp; U-Bolts</b>																												
4"	F8401K	G31, G32, G36, G37, G41	F8451	1	F540					FA450	7054	Included	7254	8054		8254	9054		9254	H7092	H7060	N8092	N8060	B8592	B8560	M9592	M9560	6
6"	F8601K	G31, G32, G36, G37, G41	F8651	1	F560					FA450	7054	Included	7254	8054		8254	9054		9254	H7093	H7079	N8093	N8079	B8593	B8579	M9593	M9579	6

KIT NOTES: Upgrade Available for 4 & 6" Kit. Part # F58484LU. Radius Arm Conversion to Uper & Lower Control Arms. G31. Lift is Designed to Level Models with Factory 1 7/8" Rear Blocks. Models with Optional Factory 3 7/8" Rear Blocks will have a Higher Rake Angle in the Rear. G32. Lift Heights will Vary Depending on Factory Package Options. G36. Model with Rear Sway Bar must Oder Extended Rear Sway Bar End Links. 4" Lifts Order Part # SBE404, 6" Lifts Order Part # SBE405. G37. Models Equipped with a Sterling Rear Axle will Need Wider Rear U-Bolts. 4" Lifts Order Part # U9B16R, 4" Systems Order Part # U9B12R, 6" Kits Order Part # U9B18R, 6" Systems Order Part # U9B12R. G41. 4, 6, & 8.5" Lifts Require Minor Exhaust Modifications.

<b>08-10 F-250 Super Duty (Gas Engine) 4WD System Gas Engines with Rear Springs</b>																												
4"	F8401KS	G31, G32, G36, G37, G41	F8451S	1	F540	2	FR84S			FA450	7054	Included	7254	8054		8254	9054		9254	H7092	H7060	N8092	N8060	B8592	B8560	M9592	M9560	6
6"	F8601KS	G31, G32, G36, G37, G41	F8651S	1	F560	2	FR86S			FA450	7054	Included	7254	8054		8254	9054		9254	H7093	H7079	N8093	N8079	B8593	B8579	M9593	M9579	6

KIT NOTES: Upgrade Available for 4 & 6" Kit. Part # F58484LU. Radius Arm Conversion to Uper & Lower Control Arms. G31. Lift is Designed to Level Models with Factory 1 7/8" Rear Blocks. Models with Optional Factory 3 7/8" Rear Blocks will have a Higher Rake Angle in the Rear. G32. Lift Heights will Vary Depending on Factory Package Options. G36. Model with Rear Sway Bar must Oder Extended Rear Sway Bar End Links. 4" Lifts Order Part # SBE404, 6" Lifts Order Part # SBE405. G37. Models Equipped with a Sterling Rear Axle will Need Wider Rear U-Bolts. 4" Lifts Order Part # U9B16R, 4" Systems Order Part # U9B12R, 6" Kits Order Part # U9B18R, 6" Systems Order Part # U9B12R. G41. 4, 6, & 8.5" Lifts Require Minor Exhaust Modifications.

**CLASS II - ADJUSTABLE 4-LINKS**

<b>08-10 F-250 Super Duty (Gas Engine) 4WD Class II Kit Class II Gas Engines with Blocks &amp; U-Bolts</b>																												
4"	F84024K	G31, G32, G36, G37, G41	F8451 + F58484LU	1	F540					FA450	7054	Included	7254	8054		8254	9054		9254	H7092	H7060	N8092	N8060	B8592	B8560	M9592	M9560	6
6"	F86024K	G31, G32, G36, G37, G41	F8651 + F58484LU	1	F560					FA450	7054	Included	7254	8054		8254	9054		9254	H7093	H7079	N8093	N8079	B8593	B8579	M9593	M9579	6

<b>08-10 F-250 Super Duty (Gas Engine) 4WD System Class II Gas Engines with Rear Springs</b>																												
4"	F84024KS	G31, G32, G36, G37, G41	F8451S + F58484LU	1	F540	2	FR84S			FA450	7054	Included	7254	8054		8254	9054		9254	H7092	H7060	N8092	N8060	B8592	B8560	M9592	M9560	6
6"	F86024KS	G31, G32, G36, G37, G41	F8651S + F58484LU	1	F560	2	FR86S			FA450	7054	Included	7254	8054		8254	9054		9254	H7093	H7079	N8093	N8079	B8593	B8579	M9593	M9579	6





LIFT	Quick Kit Reference	KIT NOTES (Requires 1 Of Each)	Component Box		Front Springs		Rear Springs		Add-A-Leafs	Steering Correction (Order 1 Each)	Steering Stabilizers									HYDRO Shocks		NITRO Shocks		BLACK MAX		M95 Shocks		Labor Hours	
			Qty	Part #	Qty	Part #	White				Black			Silver			White		White		Black		Silver						
							OEM	Single			Dual	OEM	Single	Dual	OEM	Single	Dual	Front	Rear	Front	Rear	Front	Rear	Front	Rear				
<b>03/99-99 F-250 SUPER DUTY 4WD (BUILT AFTER MARCH '99 - WITH SQUARE FRONT U-BOLTS)</b>											<b>NOTE: ALL SHOCKS MUST BE ORDERED SEPARATELY.</b>																		
<b>SOFTRIDE® LIFT SYSTEMS</b>																													
<b>03/99-99 F-250 Super Duty 4WD Kit</b>											<b>All Engines with Front Add-A-Leafs</b>																		
2-2.5"	F93203K			TB9203					F9320			7099	7199	7299	8099	8199	8299	9099	9199	9299	H7023	H7060	N8023	N8060	B8523	B8560	M9523	M9560	4
<b>03/99-99 F-250 Super Duty 4WD Kit</b>											<b>All Engines with Replacement Front Springs</b>																		
1.5-2"	F9203K			F9203M	2	F920S						7099	7199	7299	8099	8199	8299	9099	9199	9299	H7023	H7060	N8023	N8060	B8523	B8560	M9523	M9560	4
<b>03/99-99 F-250 Super Duty 4WD Kit</b>											<b>Gas V8 or V10 Engine with Blocks &amp; U-Bolts</b>																		
4"	F9403MK	G7, G8		F9403M	2	F940S				FA499		7099	7199	7299	8099	8199	8299	9099	9199	9299	H7041	H7079	N8041	N8079	B8541	B8579	M9541	M9579	8
6"	F9603MK	G7, G8, G25		F9603M	2	F960S				FA499		7099	7199	7299	8099	8199	8299	9099	9199	9299	H7060	H7099	N8060	N8099	B8560	B8599	M9560	M9599	8
KIT NOTES: G7. 3/99-03 Ford Super Duty - if Equipped with a Factory 1.875" Rear Block, the Vehicle will Sit Level. G8. Power Steering Models Only. G25. # SBE405 may be Required on Models Equipped with Factory Rear Sway Bar.																													
<b>03/99-99 F-250 Super Duty 4WD System</b>											<b>Gas V8 or V10 Engine with Replacement Rear Springs</b>																		
4"	F9403MKS	G7, G8		F9403MS	2	F940S	2	FR94S		FA499		7099	7199	7299	8099	8199	8299	9099	9199	9299	H7041	H7079	N8041	N8079	B8541	B8579	M9541	M9579	8
6"	F9603MKS	G7, G8, G25		F9603MS	2	F960S	2	FR96S		FA499		7099	7199	7299	8099	8199	8299	9099	9199	9299	H7060	H7099	N8060	N8099	B8560	B8599	M9560	M9599	8
8"	F9803MKS-A	G7, G8		F9803MS	2	F965S	2	FR98S		Included		7099	7199	7299	8099	8199	8299	9099	9199	9299	H7060	H7099	N8060	N8099	B8560	B8599	M9560	M9599	8
KIT NOTES: G7. 3/99-03 Ford Super Duty - if Equipped with a Factory 1.875" Rear Block, the Vehicle will Sit Level. G8. Power Steering Models Only. G25. # SBE405 may be Required on Models Equipped with Factory Rear Sway Bar.																													
<b>03/99-99 F-250 Super Duty 4WD Kit</b>											<b>Diesel Engine with Blocks &amp; U-Bolts</b>																		
4"	F9453MK	G7, G8		F9403M	2	F945S				FA499		7099	7199	7299	8099	8199	8299	9099	9199	9299	H7041	H7079	N8041	N8079	B8541	B8579	M9541	M9579	8
6"	F9653MK	G7, G8, G25		F9603M	2	F965S				FA499		7099	7199	7299	8099	8199	8299	9099	9199	9299	H7060	H7099	N8060	N8099	B8560	B8599	M9560	M9599	8
KIT NOTES: G7. 3/99-03 Ford Super Duty - if Equipped with a Factory 1.875" Rear Block, the Vehicle will Sit Level. G8. Power Steering Models Only. G25. # SBE405 may be Required on Models Equipped with Factory Rear Sway Bar.																													
<b>03/99-99 F-250 Super Duty 4WD System</b>											<b>Diesel Engine with Replacement Rear Springs</b>																		
4"	F9453MKS	G7, G8		F9403MS	2	F945S	2	FR94S		FA499		7099	7199	7299	8099	8199	8299	9099	9199	9299	H7041	H7079	N8041	N8079	B8541	B8579	M9541	M9579	8
6"	F9653MKS	G7, G8, G25		F9603MS	2	F965S	2	FR96S		FA499		7099	7199	7299	8099	8199	8299	9099	9199	9299	H7060	H7099	N8060	N8099	B8560	B8599	M9560	M9599	8
8"	F9853MKS-A	G7, G8		F9803MS	2	F985S	2	FR98S		Included		7099	7199	7299	8099	8199	8299	9099	9199	9299	H7060	H7099	N8060	N8099	B8560	B8599	M9560	M9599	8
KIT NOTES: G7. 3/99-03 Ford Super Duty - if Equipped with a Factory 1.875" Rear Block, the Vehicle will Sit Level. G8. Power Steering Models Only. G25. # SBE405 may be Required on Models Equipped with Factory Rear Sway Bar.																													
<b>99-02/99 F-250 SUPER DUTY 4WD (BUILT BEFORE MARCH '99)</b>											<b>NOTE: ALL SHOCKS MUST BE ORDERED SEPARATELY.</b>																		
<b>99-02/99 F-250 Super Duty 4WD Kit</b>											<b>All Engines with Front Add-A-Leafs</b>																		
2-2.5"	F9320K			TB920	1	F9320						7099	7199	7299	8099	8199	8299	9099	9199	9299	H7023	H7060	N8023	N8060	B8523	B8560	M9523	M9560	4
<b>99-02/99 F-250 Super Duty 4WD Kit</b>											<b>Gas V8 or V10 Engine with Blocks &amp; U-Bolts</b>																		
4"	F940MK	G8		F940M	2	F940S				FA400		7099	7199	7299	8099	8199	8299	9099	9199	9299	H7041	H7079	N8041	N8079	B8541	B8579	M9541	M9579	8
6"	F960MK	G8, G25		F960M	2	F960S				FA400		7099	7199	7299	8099	8199	8299	9099	9199	9299	H7060	H7099	N8060	N8099	B8560	B8599	M9560	M9599	8
KIT NOTES: G8. Power Steering Models Only. G25. # SBE405 may be Required on Models Equipped with Factory Rear Sway Bar.																													
<b>99-02/99 F-250 Super Duty 4WD System</b>											<b>Gas V8 or V10 Engine with Replacement Rear Springs</b>																		
4"	F940MKS	G8, G10		F940MS	2	F940S	2	FR96S		FA400		7099	7199	7299	8099	8199	8299	9099	9199	9299	H7041	H7079	N8041	N8079	B8541	B8579	M9541	M9579	8
6"	F960MKS	G8, G25		F960MS	2	F960S	2	FR94S		FA400		7099	7199	7299	8099	8199	8299	9099	9199	9299	H7060	H7099	N8060	N8099	B8560	B8599	M9560	M9599	8
8"	F980MKS-A	G8		F980MS	2	F965S	2	FR96S		Included		7099	7199	7299	8099	8199	8299	9099	9199	9299	H7060	H7099	N8060	N8099	B8560	B8599	M9560	M9599	8
KIT NOTES: G8. Power Steering Models Only. G10. The Factory Block is Removed. G25. # SBE405 may be Required on Models Equipped with Factory Rear Sway Bar.																													
<b>99-02/99 F-250 Super Duty 4WD Kit</b>											<b>Diesel Engine with Blocks &amp; U-Bolts</b>																		
4"	F945MK	G8		F940M	2	F945S				FA400		7099	7199	7299	8099	8199	8299	9099	9199	9299	H7041	H7079	N8041	N8079	B8541	B8579	M9541	M9579	8
6"	F965MK	G8, G25		F960M	2	F965S				FA400		7099	7199	7299	8099	8199	8299	9099	9199	9299	H7060	H7099	N8060	N8099	B8560	B8599	M9560	M9599	8
KIT NOTES: G8. Power Steering Models Only. G25. # SBE405 may be Required on Models Equipped with Factory Rear Sway Bar.																													
<b>99-02/99 F-250 Super Duty 4WD System</b>											<b>Diesel Engine with Replacement Rear Springs</b>																		
4"	F945MKS	G8, G10		F940MS	2	F945S	2	FR96S		FA400		7099	7199	7299	8099	8199	8299	9099	9199	9299	H7041	H7079	N8041	N8079	B8541	B8579	M9541	M9579	8
6"	F965MKS	G8, G25		F960MS	2	F965S	2	FR94S		FA400		7099	7199	7299	8099	8199	8299	9099	9199	9299	H7060	H7099	N8060	N8099	B8560	B8599	M9560	M9599	8
8"	F985MKS-A	G8		F980MS	2	F985S	2	FR96S		Included		7099	7199	7299	8099	8199	8299	9099	9199	9299	H7060	H7099	N8060	N8099	B8560	B8599	M9560	M9599	8
KIT NOTES: G8. Power Steering Models Only. G10. The Factory Block is Removed. G25. # SBE405 may be Required on Models Equipped with Factory Rear Sway Bar.																													
<b>97-00 F-250 LIGHT DUTY ONLY - 7 LUG (TORSION BAR FRONT END)</b>											<b>NOTE: ALL SHOCKS MUST BE ORDERED SEPARATELY.</b>																		
<b>97-00 F250, Light Duty Only 7 Lug</b>											<b>Torsion Keys (Front Leveling Kit)</b>																		
2.5"	F301KE			F301KE																									
<b>87-98 F-250 INDEPENDENT FRONT SUSPENSION 4WD (IFS)</b>											<b>NOTE: ALL SHOCKS MUST BE ORDERED SEPARATELY.</b>																		
<b>87-98 F-250 (IFS) 4WD Kit</b>											<b>302 or 351 Engine with Front Add-A-Leafs</b>																		
1.5-2"	F35G	G1, G18							F35G				7140	7240		8140	8240		9140	9240	H7023	H7058	N8023	N8058	B8523	B8558	M9523	M9558	4
KIT NOTES: G1. Oversized Camber / Caster Shims are Required (See Ford Accessories Section). G18. See Brake Lines Section.																													

FORD

FORD



LIFT	Quick Kit Reference	KIT NOTES	Component Box (Requires 1 Of Each)	Front Springs		Rear Springs		Add-A-Leafs	Steering Correction (Order 1 Each)	Steering Stabilizers						HYDRO Shocks		NITRO Shocks		BLACK MAX		M95 Shocks		Labor Hours							
				Qty	Part #	Qty	Part #			White		Black		Silver		White		Black		Silver											
										OEM	Single	Dual	OEM	Single	Dual	OEM	Single	Dual	Front	Rear	Front	Rear	Front		Rear	Front	Rear				
<b>87-98 F-250 (IFS) 4WD Kit</b>																															
<b>460 or Diesel Engine with Front Add-A-Leafs</b>																															
1.5-2"	F46D	G1, G18						F46D			7140	7240		8140	8240		9140	9240	H7023	H7058	N8023	N8058	B8523	B8558	M9523	M9558	4				
KIT NOTES: G1. Oversized Camber / Caster Shims are Required (See Ford Accessories Section). G18. See Brake Lines Section.																															
<b>87-98 F-250 (IFS) 4WD Kit</b>																															
<b>Standard Brackets with Blocks &amp; U-Bolts</b>																															
4"	F840TK	G8, G18, G22, G23	F840T	2	F840S				FA400		7140	7240		8140	8240		9140	9240	H7041	H7060	N8041	N8060	B8541	B8560	M9541	M9560	6				
6"	F860TK	G8, G18, G22, G23	F860T	2	F860S				FA400		7140	7240		8140	8240		9140	9240	H7041	H7060	N8041	N8060	B8541	B8560	M9541	M9560	8				
KIT NOTES: G8. Power Steering Models Only. G18. See Brake Lines Section. G22. May Require End Links on Models Equipped with Factory Sway Bars. See Ford Accessories. G23. Vehicles with Diesel Engine will Require Front Fitted Leafs. Vehicles with Extra Weight may Require Fitted Leafs. See Leaf Springs Section.																															
<b>87-98 F-250 (IFS) 4WD Kit</b>																															
<b>For Rear Towing Package with Blocks &amp; U-Bolts</b>																															
4"	F840TK3	G8, G18, G22, G23	F840TH	2	F840S				FA400		7140	7240		8140	8240		9140	9240	H7041	H7060	N8041	N8060	B8541	B8560	M9541	M9560	6				
6"	F860TK3	G8, G18, G22, G23	F860TH	2	F860S				FA400		7140	7240		8140	8240		9140	9240	H7041	H7060	N8041	N8060	B8541	B8560	M9541	M9560	8				
KIT NOTES: G8. Power Steering Models Only. G18. See Brake Lines Section. G22. May Require End Links on Models Equipped with Factory Sway Bars. See Ford Accessories. G23. Vehicles with Diesel Engine will Require Front Fitted Leafs. Vehicles with Extra Weight may Require Fitted Leafs. See Leaf Springs Section.																															
<b>87-98 F-250 (IFS) 4WD System</b>																															
<b>Standard Brackets with Replacement Rear Springs</b>																															
4"	F840TKS	G8, G18, G22, G23	F840TS	2	F840S	2	FR54S		FA400		7140	7240		8140	8240		9140	9240	H7041	H7060	N8041	N8060	B8541	B8560	M9541	M9560	6				
6"	F860TKS	G8, G18, G22, G23	F860TS	2	F860S	2	FR56S		FA400		7140	7240		8140	8240		9140	9240	H7041	H7060	N8041	N8060	B8541	B8560	M9541	M9560	8				
KIT NOTES: G8. Power Steering Models Only. G18. See Brake Lines Section. G22. May Require End Links on Models Equipped with Factory Sway Bars. See Ford Accessories. G23. Vehicles with Diesel Engine will Require Front Fitted Leafs. Vehicles with Extra Weight may Require Fitted Leafs. See Leaf Springs Section.																															
<b>80-86 F-250 INDEPENDENT FRONT SUSPENSION 4WD (IFS)</b>												<b>NOTE: ALL SHOCKS MUST BE ORDERED SEPARATELY.</b>																			
<b>80-86 F-250 (IFS) 4WD Kit</b>																															
<b>302 or 351 Engine with Front Add-A-Leafs</b>																															
1.5-2"	F35G	G1, G18						F35G			7140	7240		8140	8240		9140	9240	H7054	H7058	N8054	N8058	B8554	B8558	M9554	M9558	4				
KIT NOTES: G1. Oversized Camber / Caster Shims are Required (See Ford Accessories Section). G18. See Brake Lines Section.																															
<b>80-86 F-250 (IFS) 4WD Kit</b>																															
<b>460 or Diesel Engine with Front Add-A-Leafs</b>																															
1.5-2"	F46D	G1, G18						F46D			7140	7240		8140	8240		9140	9240	H7054	H7058	N8054	N8058	B8554	B8558	M9554	M9558	4				
KIT NOTES: G1. Oversized Camber / Caster Shims are Required (See Ford Accessories Section). G18. See Brake Lines Section.																															
<b>80-86 F-250 (IFS) 4WD Kit</b>																															
<b>Standard Brackets with Blocks &amp; U-Bolts</b>																															
4"	F840TK	G8, G18, G22, G23	F840T	2	F840S				FA400		7140	7240		8140	8240		9140	9240	H7055	H7060	N8055	N8060	B8555	B8560	M9555	M9560	6				
6"	F860TK	G8, G18, G22, G23	F860T	2	F860S				FA400		7140	7240		8140	8240		9140	9240	H7056	H7060	N8056	N8060	B8555	B8560	M9556	M9560	8				
KIT NOTES: G8. Power Steering Models Only. G18. See Brake Lines Section. G22. May Require End Links on Models Equipped with Factory Sway Bars. See Ford Accessories. G23. Vehicles with Diesel Engine will Require Front Fitted Leafs. Vehicles with Extra Weight may Require Fitted Leafs. See Leaf Springs Section.																															
<b>80-86 F-250 (IFS) 4WD Kit</b>																															
<b>For Rear Towing Package with Blocks &amp; U-Bolts</b>																															
4"	F840TK3	G8, G18, G22, G23	F840TH	2	F840S				FA400		7140	7240		8140	8240		9140	9240	H7055	H7060	N8055	N8060	B8555	B8560	M9555	M9560	6				
6"	F860TK3	G8, G18, G22, G23	F860TH	2	F860S				FA400		7140	7240		8140	8240		9140	9240	H7056	H7060	N8056	N8060	B8555	B8560	M9556	M9560	8				
KIT NOTES: G8. Power Steering Models Only. G18. See Brake Lines Section. G22. May Require End Links on Models Equipped with Factory Sway Bars. See Ford Accessories. G23. Vehicles with Diesel Engine will Require Front Fitted Leafs. Vehicles with Extra Weight may Require Fitted Leafs. See Leaf Springs Section.																															
<b>80-86 F-250 (IFS) 4WD System</b>																															
<b>Standard Brackets with Replacement Rear Springs</b>																															
4"	F840TKS	G8, G18, G22, G23	F840TS	2	F840S	2	FR54S		FA400		7140	7240		8140	8240		9140	9240	H7055	H7060	N8055	N8060	B8555	B8560	M9555	M9560	6				
6"	F860TKS	G8, G18, G22, G23	F860TS	2	F860S	2	FR56S		FA400		7140	7240		8140	8240		9140	9240	H7056	H7060	N8056	N8060	B8555	B8560	M9556	M9560	8				
KIT NOTES: G8. Power Steering Models Only. G18. See Brake Lines Section. G22. May Require End Links on Models Equipped with Factory Sway Bars. See Ford Accessories. G23. Vehicles with Diesel Engine will Require Front Fitted Leafs. Vehicles with Extra Weight may Require Fitted Leafs. See Leaf Springs Section.																															
<b>80-96 F-250 2WD WITH DIESEL OR 460 ENGINES</b>												<b>NOTE: ALL SHOCKS MUST BE ORDERED SEPARATELY.</b>																			
<b>80-96 F-250 2WD Kit</b>																															
<b>With Blocks &amp; U-Bolts</b>																															
3"	184F2K	G8, G18	184F2	1	184				FA400		7140	7240		8140	8240		9140	9240	H7054	H7058	N8054	N8058	B8554	B8558	M9554	M9558	6				
5"	186F2K	G8, G18	186F2	1	186				FA400		7140	7240		8140	8240		9140	9240	H7055	H7041	N8055	N8041	B8555	B8541	M9555	M9541	6				
KIT NOTES: G8. Power Steering Models Only. G18. See Brake Lines Section.																															
<b>77.5-79 F-250 LOW BOY &amp; 79 F-150 SUPERCAB 4WD WITH 3" WIDE REAR SPRINGS</b>												<b>NOTE: ALL SHOCKS MUST BE ORDERED SEPARATELY.</b>																			
<b>77.5-79 F-250 Low Boy 4WD Kit</b>																															
<b>With Front Add-A-Leafs</b>																															
1.5-2"	F46D	G18						F46D			7110	7220		8110	8220		9110	9220	---	---	H7055	---	---	N8055	---	---	B8555	---	---	M9555	4
KIT NOTES: G18. Brake Lines Available.																															
<b>77.5-79 F-250 Low Boy 4WD Kit</b>																															
<b>With Blocks &amp; U-Bolts</b>																															
4"	F749K	G18	F749	2	F724S				SDL250		7110	7220		8110	8220		9110	9220	---	---	H7056	N8014	N8056	B8514	B8556	M9514	M9556	4			
6"	F760K	G18	F760	2	F746S				SDL250 + FA325		7110	7220		8110	8220		9110	9220	---	---	H7059	N8014	N8059	B8514	B8559	M9514	M9559	6			
KIT NOTES: G18. See Brake Lines Section.																															
<b>77.5-79 F-250 Low Boy 4WD System</b>																															
<b>With Replacement Rear Springs</b>																															
4"	F749KS	G18	F749S	2	F724S	2	FR54S		SDL250		7110	7220		8110	8220		9110	9220	---	---	H7056	N8014	N8056	B8514	B8556	M9514	M9556	4			
6"	F760KS	G18	F760S	2	F746S	2	FR56S		SDL250 + FA325		7110	7220		8110	8220		9110	9220	---	---	H7059	N8014	N8059	B8514	B8559	M9514	M9559	6			
KIT NOTES: G18. See Brake Lines Section.																															

FORD

FORD

LIFT	Quick Kit Reference	KIT NOTES	Component Box		Front Springs		Rear Springs		Add-A-Leafs	Steering Correction (Order 1 Each)	Steering Stabilizers						HYDRO Shocks		NITRO Shocks		BLACK MAX		M95 Shocks		Labor Hours											
			(Requires 1 Of Each)		Qty	Part #	Qty	Part #			White			Black			Silver			White		Black		Silver												
			OEM	Single	Dual	OEM	Single	Dual			OEM	Single	Dual	Front	Rear	Front	Rear	Front	Rear	Front	Rear	Front	Rear													
<b>67-77 F-250 HIGH BOY 4WD WITH 2 1/4" WIDE REAR SPRINGS</b>											<b>NOTE: ALL SHOCKS MUST BE ORDERED SEPARATELY.</b>																									
<b>67-77 F-250 High Boy 4WD Kit</b>											<b>With Blocks &amp; U-Bolts</b>																									
2"	F720K	G18	F7240	2	F724S				R5005			7110	7220		8110	8220		9110	9220	---	---	H7058	N8014	N8058	B8514	B8558	M9514	M9558	4							
4"	F740K	G18	F7240	2	F746S				R225			7110	7220		8110	8220		9110	9220	---	---	H7058	N8014	N8058	B8514	B8558	M9514	M9558	4							
KIT NOTES: G18. See Brake Lines Section.																																				
<b>67-77 F-250 High Boy 4WD System</b>											<b>With Replacement Rear Springs</b>																									
2"	F720KS	G6, G10, G18	F720S	2	F724S	2	FR74S					7110	7220		8110	8220		9110	9220	---	---	H7058	N8014	N8058	B8514	B8558	M9514	M9558	4							
4"	F740KS	G18	F740S	2	F746S	2	FR74S					7110	7220		8110	8220		9110	9220	---	---	H7058	N8014	N8058	B8514	B8558	M9514	M9558	4							
KIT NOTES: G6. The Factory Blocks are Replaced with Included 2" Blocks. G10. The Factory Block is Removed. G18. See Brake Lines Section.																																				
<b>17-18 F-350 SUPER DUTY 4WD</b>											<b>NOTE: ALL SHOCKS MUST BE ORDERED SEPARATELY.</b>																									
<b>17-18 F-350 Super Duty 4WD Kit</b>											<b>Front Metal Spacers</b>																									
1"	F51MS		F51MS									7054			8054			9054				H7091	H7038	N8091	N8038	B8591	B8538	M9591	M9538	2						
<b>17-18 F-350 Super Duty 4WD Kit</b>											<b>Front Metal Spacers with Front Track Bar Bracket</b>																									
2.5"	F528MSP		F528MSP									7054			8054			9054				H7091	H7038	N8091	N8038	B8591	B8538	M9591	M9538	3						
<b>17-18 F-350 Super Duty 4WD Kit</b>											<b>Front Metal Spacers with Shock Extension Brackets</b>																									
2.5"	F1752MSB	G40	F1752MSB									7054			8054			9054			---	---	H7038	---	---	N8038	---	---	B8538	---	---	M9538	4			
<b>17-18 F-350 Super Duty 4WD Kit (Diesel Engine)</b>											<b>Variable Rate Front Coil Springs</b>																									
2.5"	F525V	G40	F525V		Included							7054			8054			9054				H7091	H7038	N8091	N8038	B8591	B8538	M9591	M9538	2						
<b>17-18 F-350 Super Duty 4WD Kit (Gas Engine)</b>											<b>Softride® Front Coil Springs</b>																									
2"	F520	G40	F520		Included							7054			8054			9054				H7091	H7038	N8091	N8038	B8591	B8538	M9591	M9538	2						
KIT NOTES: G40. Front Track Bar Relocation Bracket Required - Part # TB1120																																				
<b>17-18 F-350 Super Duty 4WD Kit (Diesel or Gas)</b>											<b>Metal Spacer Kit with Blocks &amp; U-Bolts and Black MAX Shocks</b>																									
4"	F1740SPB3	G42	F1740SPB3												7254			8254			9254	---	---	---	---	---	---	---	---	Included	Included	---	---	---	---	6
Kit includes front coil spring spacers, front & rear Black MAX shocks, track bar relocation bracket, radius arm relocation brackets, steering stabilizer bracket, front sway bar lowering brackets, front bump stop spacers, front brake line extension brackets, rear lift blocks, & rear u-bolts.																																				
<b>17-18 F-350 Super Duty 4WD Kit (Diesel Engine)</b>											<b>Variable Rate Front Coil Springs with Rear Blocks &amp; U-Bolts</b>																									
4"	F17451K3	G42	F174513	1	F545V										7254			8254			9254	H7092	H7068	N8092	N8068	B8592	B8568	M9592	M9568	6						
6"	F17651K3	G43	F176513	1	F565V				Included						7254			8254			9254	H7093	H7068	N8093	N8068	B8593	B8568	M9593	M9568	6						
<b>17-18 F-350 Super Duty 4WD System (Diesel Engine)</b>											<b>Variable Rate Front Coil Springs with Rear Leaf Springs</b>																									
4"	F17451KS	G42	F17451S	1	F545V	2	FR173S								7254			8254			9254	H7092	H7068	N8092	N8068	B8592	B8568	M9592	M9568	6						
6"	F17651KS	G43	F17651S	1	F565V	2	FR175S		Included						7254			8254			9254	H7093	H7068	N8093	N8068	B8593	B8568	M9593	M9568	6						
<b>17-18 F-350 Super Duty 4WD Kit (Gas Engine)</b>											<b>Softride® Front Coil Springs with Rear Blocks &amp; U-Bolts</b>																									
4"	F17401K3	G42	F174513	1	F540										7254			8254			9254	H7092	H7068	N8092	N8068	B8592	B8568	M9592	M9568	6						
6"	F17601K3	G43	F176513	1	F560				Included						7254			8254			9254	H7093	H7068	N8093	N8068	B8593	B8568	M9593	M9568	6						
<b>17-18 F-350 Super Duty 4WD System (Gas Engine)</b>											<b>Softride® Front Coil Springs with Rear Leaf Springs</b>																									
4"	F17401KS	G42	F17451S	1	F540	2	FR173S								7254			8254			9254	H7092	H7068	N8092	N8068	B8592	B8568	M9592	M9568	6						
6"	F17601KS	G43	F17651S	1	F560	2	FR175S		Included						7254			8254			9254	H7093	H7068	N8093	N8068	B8593	B8568	M9593	M9568	6						
KIT NOTES: G42. Lift is specifically designed to not require a drop pitman arm. G43. If front drive shaft vibration occurs, front drive shaft modification is required or order a new front drive shaft Part # F17685DS.																																				
<b>CLASS II - ADJUSTABLE 4-LINKS</b>																																				
<b>17-18 F-350 Super Duty 4WD Class II Kit (Diesel Engine)</b>											<b>Variable Rate Front Coil Springs with Rear Blocks &amp; U-Bolts</b>																									
4"	F174524K3	G42	F174513 + F58484LU	1	F545V										7254			8254			9254	H7092	H7068	N8092	N8068	B8592	B8568	M9592	M9568	8						
6"	F176524K3	G43	F176513 + F58484LU	1	F565V				Included						7254			8254			9254	H7093	H7068	N8093	N8068	B8593	B8568	M9593	M9568	8						
8.5"	F17852K	G43	F17852 + F58484LU	1	F585V			R3815	Included						7254			8254			9254	H7094	H7089	N8094	N8089	B8594	B8589	M9594	M9589	10						
<b>17-18 F-350 Super Duty 4WD Class II System (Diesel Engine)</b>											<b>Variable Rate Front Coil Springs with Rear Leaf Springs</b>																									
4"	F174524KS	G42	F17451S + F58484LU	1	F545V	2	FR173S								7254			8254			9254	H7092	H7068	N8092	N8068	B8592	B8568	M9592	M9568	8						
6"	F176524KS	G43	F17651S + F58484LU	1	F565V	2	FR175S		Included						7254			8254			9254	H7093	H7068	N8093	N8068	B8593	B8568	M9593	M9568	8						
8.5"	F17852KS	G43	F17852S + F58484LU	1	F585V	2	FR177S		Included						7254			8254			9254	H7094	H7089	N8094	N8089	B8594	B8589	M9594	M9589	10						
<b>17-18 F-350 Super Duty 4WD Class II Kit (Gas Engine)</b>											<b>Softride® Front Coil Springs with Rear Blocks &amp; U-Bolts</b>																									
4"	F174024K3	G42	F174513 + F58484LU	1	F540										7254			8254			9254	H7092	H7068	N8092	N8068	B8592	B8568	M9592	M9568	8						
6"	F176024K3	G43	F176513 + F58484LU	1	F560				Included						7254			8254			9254	H7093	H7068	N8093	N8068	B8593	B8568	M9593	M9568	8						
8.5"	F17802K	G43	F17852 + F58484LU	1	F565V			R3815	Included						7254			8254			9254	H7094	H7089	N8094	N8089	B8594	B8589	M9594	M9589	10						
<b>17-18 F-350 Super Duty 4WD Class II System (Gas Engine)</b>											<b>Softride® Front Coil Springs with Rear Leaf Springs</b>																									
4"	F174024KS	G42	F17451S + F58484LU	1	F540	2	FR173S								7254			8254			9254	H7092	H7068	N8092	N8068	B8592	B8568	M9592	M9568	8						
6"	F176024KS	G43	F17651S + F58484LU	1	F560	2	FR175S		Included						7254			8254			9254	H7093	H7068	N8093	N8068	B8593	B8568	M9593	M9568	8						
8.5"	F17802KS	G43	F17852S + F58484LU	1	F565V	2	FR177S		Included						7254			8254			9254	H7094	H7089	N8094	N8089	B8594	B8589	M9594	M9589	10						

FORD

FORD

LIFT	Quick Kit Reference	KIT NOTES	Component Box (Requires 1 Of Each)	Front Springs		Rear Springs		Add-A-Leafs	Steering Correction (Order 1 Each)	Steering Stabilizers						HYDRO Shocks		NITRO Shocks		BLACK MAX		M95 Shocks		Labor Hours						
				Qty	Part #	Qty	Part #			White		Black		Silver		White		White		Black		Silver								
										OEM	Single	Dual	OEM	Single	Dual	OEM	Single	Dual	Front	Rear	Front	Rear	Front		Rear	Front	Rear			
<b>LEDUC SERIES COIL-OVER KITS</b>																														
<b>17-18 F-350 Super Duty 4WD Coil-Over Kit (Diesel or Gas) Front LeDuc Series Coil-Overs with Rear Blocks &amp; U-Bolts</b>																														
6"	F1761LSK3	G43	F76FLSB + F176513	1	F768FLS				Included				7254			8254			9254		H7068		N8068		B8568		M9568	6		
<b>17-18 F-350 Super Duty 4WD Coil-Over System (Diesel or Gas) Front LeDuc Series Coil-Overs with Rear Leaf Springs</b>																														
6"	F1761LSKS	G43	F76FLSB + F17651S	1	F768FLS	2	FR175S		Included				7254			8254			9254		H7068		N8068		B8568		M9568	6		
<b>CLASS II - LEDUC SERIES COIL-OVER KITS WITH ADJUSTABLE 4-LINKS</b>																														
<b>17-18 F-350 Super Duty 4WD Class II Kit (Diesel or Gas) Front LeDuc Series Coil-Overs with Rear Blocks &amp; U-Bolts</b>																														
6"	F17624LSK3	G43	F76FLSB + F176513 + F58484LU	1	F768FLS				Included				7254			8254			9254		H7068		N8068		B8568		M9568	9		
8.5"	F1782LSK	G43	F78FLSB + F17852 + F58484LU	1	F768FLS		R3815		Included				7254			8254			9254		H7089		N8089		B8589		M9589	10		
<b>17-18 F-350 Super Duty 4WD Class II System (Diesel or Gas) Front LeDuc Series Coil-Overs with Rear Leaf Springs</b>																														
6"	F17624LSKS	G43	F76FLSB + F17651S + F58484LU	1	F768FLS	2	FR175S		Included				7254			8254			9254		H7068		N8068		B8568		M9568	9		
8.5"	F1782LSKS	G43	F78FLSB + F17852S + F58484LU	1	F768FLS	2	FR177S		Included				7254			8254			9254		H7089		N8089		B8589		M9589	10		
KIT NOTES: G42. Lift is specifically designed to not require a drop pitman arm. G43. If front drive shaft vibration occurs, front drive shaft modification is required or order a new front drive shaft Part # F17685DS.																														
<b>11-16 F-350 SUPER DUTY 4WD DIESEL ENGINE</b>												<b>NOTE: ALL SHOCKS MUST BE ORDERED SEPARATELY.</b>																		
<b>11-16 F-350 Super Duty 4WD Kit Front Metal Spacers</b>																														
1"	F51MS		F51MS										7054			8054			9054		H7091	H7060	N8091	N8060	B8591	B8560	M9591	M9560	2	
<b>11-16 F-350 Super Duty 4WD Kit Front Metal Spacers with Front Track Bar Bracket</b>																														
2.5"	F528MSP		F528MSP										7054			8054			9054		H7091	H7060	N8091	N8060	B8591	B8560	M9591	M9560	3	
<b>11-16 F-350 Super Duty 4WD Kit Front Metal Spacers with Rear Add-A-Leafs</b>																														
2.5"	F82MK	G33	F52MS				R3815						7054			8054			9054		H7091	H7060	N8091	N8060	B8591	B8560	M9591	M9560	4	
KIT NOTES: G33. Optional Track Bar Relocation Bracket may be Required. Part # TB1120.																														
<b>11-16 F-350 Super Duty (Diesel Engine) 4WD Kit Diesel Engines with Add-A-Leafs</b>																														
2"	F825K	G33		1	F525V		R3815						7054			8054			9054		H7091	H7060	N8091	N8060	B8591	B8560	M9591	M9560	4	
KIT NOTES: G33. Optional Track Bar Relocation Bracket may be Required. Part # TB1120.																														
<b>11-16 F-350 Super Duty (Diesel Engine) 4WD Kit Diesel Engines with Blocks &amp; U-Bolts</b>																														
4"	F11451K3	G32, G36	F11451 + F114H	1	F545V				FA450				7054	Bkt. Incl.	7254	8054	Bkt. Incl.	8254	9054	Bkt. Incl.	9254	H7092	H7079	N8092	N8079	B8592	B8579	M9592	M9579	6
6"	F11651K3	G32, G36	F11651 + F1168H	1	F565V				FA450				7054	Bkt. Incl.	7254	8054	Bkt. Incl.	8254	9054	Bkt. Incl.	9254	H7093	H7079	N8093	N8079	B8593	B8579	M9593	M9579	6
<b>CLASS II - ADJUSTABLE 4-LINKS</b>																														
<b>11-16 F-350 Super Duty (Diesel Engine) 4WD Class II Kit Diesel Engines with Blocks &amp; U-Bolts</b>																														
4"	F114524K3	G32, G36	F11451 + F114H + F58484LU	1	F545V				FA450				7054	Bkt. Incl.	7254	8054	Bkt. Incl.	8254	9054	Bkt. Incl.	9254	H7092	H7079	N8092	N8079	B8592	B8579	M9592	M9579	6
6"	F116524K3	G32, G36	F11651 + F1168H + F58484LU	1	F565V				FA450				7054	Bkt. Incl.	7254	8054	Bkt. Incl.	8254	9054	Bkt. Incl.	9254	H7093	H7079	N8093	N8079	B8593	B8579	M9593	M9579	6
<b>11-16 F-350 Super Duty (Diesel Engine) 4WD Class II Kit Diesel Engines with Blocks &amp; U-Bolts</b>																														
8.5"	F11852K3	G32, G36	F11852 + F1168H + F58484LU	1	F585V		R3815		FA450				7054		7254	8054		8254	9054		9254	H7094	H7099	N8094	N8099	B8594	B8599	M9594	M9599	12
KIT NOTES: Upgrade Available for 4 & 6" Kit. Part # F58484LU. Radius Arm Conversion to Upper & Lower Control Arms. G32. Lift Heights will Vary Depending on Factory Package Options. G36. Model with Rear Sway Bar must Order Extended Rear Sway Bar End Links. 4" Lifts Order Part # SBE404, 6" Lifts Order Part # SBE405, 8.5" Lifts Order Part # SBE406.																														
<b>08-10 F-350 SUPER DUTY 4WD DIESEL ENGINE</b>												<b>NOTE: ALL SHOCKS MUST BE ORDERED SEPARATELY.</b>																		
<b>08-10 F-350 Super Duty 4WD Kit Front Metal Spacers</b>																														
1"	F51MS		F51MS										7054			8054			9054		H7091	H7060	N8091	N8060	B8591	B8560	M9591	M9560	2	
<b>08-10 F-350 Super Duty 4WD Kit Front Metal Spacers with Front Track Bar Bracket</b>																														
2.5"	F528MSP		F528MSP										7054			8054			9054		H7091	H7060	N8091	N8060	B8591	B8560	M9591	M9560	3	
<b>08-10 F-350 Super Duty (Diesel Engine) 4WD Kit Diesel Engines with Add-A-Leafs</b>																														
2.5"	F825K	G33		1	F525V		R3815						7054			8054			9054		H7091	H7060	N8091	N8060	B8591	B8560	M9591	M9560	4	
<b>08-10 F-350 Super Duty (Diesel Engine) 4WD Kit Diesel Engines with Blocks &amp; U-Bolts</b>																														
4"	F8451K3	G31, G32, G36	F8451H	1	F545V				FA450				7054	Included	7254	8054		8254	9054		9254	H7092	H7079	N8092	N8079	B8592	B8579	M9592	M9579	6
6"	F8651K3	G31, G32, G36	F8651H	1	F565V				FA450				7054	Included	7254	8054		8254	9054		9254	H7093	H7079	N8093	N8079	B8593	B8579	M9593	M9579	6
KIT NOTES: Upgrade Available for 4 & 6" Kit. Part # F58484LU. Radius Arm Conversion to Upper & Lower Control Arms. G31. Lift is Designed to Level Models with Factory 1 7/8" Rear Blocks. Models with Optional Factory 3 7/8" Rear Blocks will have a Higher Rake Angle in the Rear. G32. Lift Heights will Vary Depending on Factory Package Options. G33. Optional Track Bar Relocation Bracket may be Required. Part # TB1120. G36. Model with Rear Sway Bar must Order Extended Rear Sway Bar End Links. 4" Lifts Order Part # SBE404, 6" Lifts Order Part # SBE405.																														

FORD

FORD

LIFT	Quick Kit Reference	KIT NOTES	Component Box (Requires 1 Of Each)	Front Springs		Rear Springs		Add-A-Leafs	Steering Correction (Order 1 Each)	Steering Stabilizers						HYDRO Shocks		NITRO Shocks		BLACK MAX		M95 Shocks		Labor Hours	
				Qty	Part #	Qty	Part #			White		Black		Silver		White		White		Black		Silver			
										OEM	Single	Dual	OEM	Single	Dual	OEM	Single	Dual	Front	Rear	Front	Rear	Front		Rear
<b>08-10 F-350 Super Duty (Diesel Engine) 4WD System Diesel Engines with Rear Springs</b>																									
4"	F8451KS3	G31, G32, G36	F8451SH	1	F545V	2	FR84S		FA450																
6"	F8651KS3	G31, G32, G36	F8651SH	1	F565V	2	FR86S		FA450																
KIT NOTES: Upgrade Available for 4 & 6" Kit. Part # F58484LU. Radius Arm Conversion to Upper & Lower Control Arms. G31. Lift is Designed to Level Models with Factory 1 7/8" Rear Blocks. Models with Optional Factory 3 7/8" Rear Blocks will have a Higher Rake Angle in the Rear. G32. Lift Heights will Vary Depending on Factory Package Options. G36. Model with Rear Sway Bar must Order Extended Rear Sway Bar End Links. 4" Lifts Order Part # SBE404, 6" Lifts Order Part # SBE405.																									
<b>CLASS II - ADJUSTABLE 4-LINKS</b>																									
<b>08-10 F-350 Super Duty (Diesel Engine) 4WD Class II Kit Diesel Engines with Blocks &amp; U-Bolts</b>																									
4"	F84524K3	G31, G32, G36, G37	F8451H + F58484LU	1	F545V				FA450																
6"	F86524K3	G31, G32, G36, G37	F8651H + F58484LU	1	F565V				FA450																
<b>08-10 F-350 Super Duty (Diesel Engine) 4WD Class II System Diesel Engines with Rear Springs</b>																									
4"	F84524KS3	G31, G32, G36, G37	F8451SH + F58484LU	1	F545V	2	FR84S		FA450																
6"	F86524KS3	G31, G32, G36, G37	F8651SH + F58484LU	1	F565V	2	FR86S		FA450																
<b>08-10 F-350 Super Duty (Diesel Engine) 4WD Class II Kit Diesel Engines with Blocks &amp; U-Bolts</b>																									
8.5"	F8852K3	G31, G32, G38, G39	F8852H + F58484LU	1	F585V			R300	FA450																
<b>08-10 F-350 Super Duty (Diesel Engine) 4WD Class II System Diesel Engines with Rear Springs</b>																									
8.5"	F8852KS3	G31, G32, G38	F8852SH + F58484LU	1	F585V	2	FR88S		FA450																
KIT NOTES: 8.5" Lifts - Front & Rear Driveline Modifications Necessary. Call for Details. * Recommend CV Joint at Transfer Case for some Models. G31. Lift is Designed to Level Models with Factory 1 7/8" Rear Blocks. Models with Optional Factory 3 7/8" Rear Blocks will have a Higher Rake Angle in the Rear. G32. Lift Heights will Vary Depending on Factory Package Options. G36. Model with Rear Sway Bar must Order Extended Rear Sway Bar End Links. 4" Lifts Order Part # SBE404, 6" Lifts Order Part # SBE405. G37. Models Equipped with a Sterling Rear Axle will Need Wider Rear U-Bolts. 4" Lifts Order Part # U9B16R, 4" Systems Order Part # U9B12R, 6" Kits Order Part # U9B18R, 6" Systems Order Part # U9B12R. G38. Model with Rear Sway Bar must Order Extended Rear Sway Bar End Links. 8.5" Lifts Order Part # SBE406. G39. Models Equipped with a Sterling Rear Axle will Need Wider Rear U-Bolts. 8.5" Kits Order Part # U9B18R, 8.5" Systems Order Part # U9B12R.																									
<b>08-10 F-350 SUPER DUTY 4WD GAS ENGINE</b>												<b>NOTE: ALL SHOCKS MUST BE ORDERED SEPARATELY.</b>													
<b>08-10 F-350 Super Duty 4WD Kit Front Metal Spacers</b>																									
1"	F51MS		F51MS																						
<b>08-10 F-350 Super Duty 4WD Kit Front Metal Spacers with Front Track Bar Bracket</b>																									
2.5"	F528MSP		F528MSP																						
<b>08-10 F-350 Super Duty 4WD Value Kit Front Metal Spacers with Rear Add-A-Leafs</b>																									
2.5"	F82MK	G33	F52MS					R3815																	
KIT NOTES: G33. Optional Track Bar Relocation Bracket may be Required. Part # TB1120.																									
<b>08-10 F-350 Super Duty (Gas Engine) 4WD Kit Gas Engines with Add-A-Leafs</b>																									
2"	F820K	G33		1	F520			R3815																	
KIT NOTES: G33. Optional Track Bar Relocation Bracket may be Required. Part # TB1120.																									
<b>08-10 F-350 Super Duty (Gas Engine) 4WD Kit Gas Engines with Blocks &amp; U-Bolts</b>																									
4"	F8401K3	G31, G32, G36, G41	F8451H	1	F540				FA450																
6"	F8601K3	G31, G32, G36, G41	F8651H	1	F560				FA450																
KIT NOTES: Upgrade Available for 4 & 6" Kit. Part # F58484LU. Radius Arm Conversion to Upper & Lower Control Arms. G31. Lift is Designed to Level Models with Factory 1 7/8" Rear Blocks. Models with Optional Factory 3 7/8" Rear Blocks will have a Higher Rake Angle in the Rear. G32. Lift Heights will Vary Depending on Factory Package Options. G36. Model with Rear Sway Bar must Order Extended Rear Sway Bar End Links. 4" Lifts Order Part # SBE404, 6" Lifts Order Part # SBE405. G41. 4, 6, & 8.5" Lifts Require Minor Exhaust Modifications.																									
<b>08-10 F-350 Super Duty (Gas Engine) 4WD System Gas Engines with Rear Springs</b>																									
4"	F8401KS3	G31, G32, G36, G41	F8451SH	1	F540	2	FR84S		FA450																
6"	F8601KS3	G31, G32, G36, G41	F8651SH	1	F560	2	FR86S		FA450																
KIT NOTES: Upgrade Available for 4 & 6" System. Part # F58484LU. Radius Arm Conversion to Upper & Lower Control Arms. G31. Lift is Designed to Level Models with Factory 1 7/8" Rear Blocks. Models with Optional Factory 3 7/8" Rear Blocks will have a Higher Rake Angle in the Rear. G32. Lift Heights will Vary Depending on Factory Package Options. G36. Model with Rear Sway Bar must Order Extended Rear Sway Bar End Links. 4" Lifts Order Part # SBE404, 6" Lifts Order Part # SBE405. G41. 4, 6, & 8.5" Lifts Require Minor Exhaust Modifications.																									
<b>CLASS II - ADJUSTABLE 4-LINKS</b>																									
<b>08-10 F-350 Super Duty (Gas Engine) 4WD Kit Gas Engines with Blocks &amp; U-Bolts</b>																									
4"	F84024K3	G31, G32, G36, G37, G41	F8451H + F58484LU	1	F540				FA450																
6"	F86024K3	G31, G32, G41	F8651H + F58484LU	1	F560				FA450																
<b>08-10 F-350 Super Duty (Gas Engine) 4WD System Class II Gas Engines with Rear Springs</b>																									
4"	F84024KS3	G31, G32, G36, G37, G41	F8451SH + F58484LU	1	F540	2	FR84S		FA450																
6"	F86024KS3	G31, G32, G36, G37, G41	F8651SH + F58484LU	1	F560	2	FR86S		FA450																
<b>08-10 F-350 Super Duty (Gas Engine) 4WD Kit Gas Engines with Blocks &amp; U-Bolts</b>																									
8.5"	F8802K3	G31, G32, G38, G39, G41	F8852H + F58484LU	1	F565V			R300	FA450																

FORD

FORD





LIFT	Quick Kit Reference	KIT NOTES	Component Box		Front Springs		Rear Springs		Add-A-Leafs	Steering Correction (Order 1 Each)	Steering Stabilizers									HYDRO Shocks		NITRO Shocks		BLACK MAX		M95 Shocks		Labor Hours
			(Requires 1 Of Each)		Qty	Part #	Qty	Part #			White			Black			Silver			White		White		Black		Silver		
			OEM	Single	Dual	OEM	Single	Dual			OEM	Single	Dual	Front	Rear	Front	Rear	Front	Rear	Front	Rear	Front	Rear	Front	Rear			
<b>99-2/99 F-350 SUPER DUTY 4WD (BUILT BEFORE MARCH '99)</b>											<b>NOTE: ALL SHOCKS MUST BE ORDERED SEPARATELY.</b>																	
<b>99-2/99 F-350 Super Duty 4WD Kit</b>											<b>All Engines with Front Add-A-Leafs</b>																	
2-2.5"	F9320K		TB920						F9320		7099	7199	7299	8099	8199	8299	9099	9199	9299	H7023	H7060	N8023	N8060	B8523	B8560	M9523	M9560	4
<b>99-2/99 F-350 Super Duty 4WD Kit</b>											<b>Gas V8 or V10 Engine with Blocks &amp; U-Bolts</b>																	
4"	F940MK	G8	F940M		2	F940S				FA400	7099	7199	7299	8099	8199	8299	9099	9199	9299	H7041	H7079	N8041	N8079	B8541	B8579	M9541	M9579	8
6"	F960MK	G8, G25	F960M		2	F960S				FA400	7099	7199	7299	8099	8199	8299	9099	9199	9299	H7060	H7099	N8060	N8099	B8560	B8599	M9560	M9599	8
KIT NOTES: G8. Power Steering Models Only. G25. # SBE405 may be Required on Models Equipped with Factory Rear Sway Bar.																												
<b>99-2/99 F-350 Super Duty 4WD System</b>											<b>Gas V8 or V10 Engine with Replacement Rear Springs</b>																	
4"	F940MKS	G8, G10	F940MS		2	F940S	2	FR96S		FA400	7099	7199	7299	8099	8199	8299	9099	9199	9299	H7041	H7079	N8041	N8079	B8541	B8579	M9541	M9579	8
6"	F960MKS	G8, G25	F960MS		2	F960S	2	FR94S		FA400	7099	7199	7299	8099	8199	8299	9099	9199	9299	H7060	H7099	N8060	N8099	B8560	B8599	M9560	M9599	8
8"	F980MKS-A	G8	F980MS		2	F965S	2	FR96S		Included	7099	7199	7299	8099	8199	8299	9099	9199	9299	H7060	H7099	N8060	N8099	B8560	B8599	M9560	M9599	8
KIT NOTES: G8. Power Steering Models Only. G25. # SBE405 may be Required on Models Equipped with Factory Rear Sway Bar. G10. The Factory Block is Removed.																												
<b>99-2/99 F-350 Super Duty 4WD Kit</b>											<b>Diesel Engine with Blocks &amp; U-Bolts</b>																	
4"	F945MK	G8	F940M		2	F945S				FA400	7099	7199	7299	8099	8199	8299	9099	9199	9299	H7041	H7079	N8041	N8079	B8541	B8579	M9541	M9579	8
6"	F965MK	G8, G25	F960M		2	F965S				FA400	7099	7199	7299	8099	8199	8299	9099	9199	9299	H7060	H7099	N8060	N8099	B8560	B8599	M9560	M9599	8
KIT NOTES: G8. Power Steering Models Only. G25. # SBE405 may be Required on Models Equipped with Factory Rear Sway Bar.																												
<b>99-2/99 F-350 Super Duty 4WD System</b>											<b>Diesel Engine with Replacement Rear Springs</b>																	
4"	F945MKS	G8, G10	F940MS		2	F945S	2	FR96S		FA400	7099	7199	7299	8099	8199	8299	9099	9199	9299	H7041	H7079	N8041	N8079	B8541	B8579	M9541	M9579	8
6"	F965MKS	G8, G25	F960MS		2	F965S	2	FR94S		FA400	7099	7199	7299	8099	8199	8299	9099	9199	9299	H7060	H7099	N8060	N8099	B8560	B8599	M9560	M9599	8
8"	F985MKS-A	G8	F980MS		2	F985S	2	FR96S		Included	7099	7199	7299	8099	8199	8299	9099	9199	9299	H7060	H7099	N8060	N8099	B8560	B8599	M9560	M9599	8
KIT NOTES: G8. Power Steering Models Only. G25. # SBE405 may be Required on Models Equipped with Factory Rear Sway Bar. G10. The Factory Block is Removed.																												
<b>86-98 F-350 STRAIGHT AXLE / MONO-BEAM 4WD</b>											<b>NOTE: ALL SHOCKS MUST BE ORDERED SEPARATELY.</b>																	
<b>86-98 F-350 4WD (Mono-Beam) Kit</b>											<b>All Except Crew Cabs with Front Add-A-Leafs</b>																	
1.5-2"	F35G								F35G		7110	7240		8110	8240		9110	9240	H7023	H7060	N8023	N8060	B8523	B8560	M9523	M9560	4	
<b>86-98 F-350 4WD (Mono-Beam) Kit</b>											<b>Crew Cabs with Front Add-A-Leafs</b>																	
2-2.5"	F3546K		UFF						F35G +F46D		7110	7240		8110	8240		9110	9240	H7023	H7060	N8023	N8060	B8523	B8560	M9523	M9560	4	
<b>86-98 F-350 4WD (Mono-Beam) Kit</b>											<b>With Blocks &amp; U-Bolts</b>																	
3-4"	F840MK	G8, G18, G22, G23	F840M		2	F840S				FA400	7110	7240		8110	8240		9110	9240	H7041	H7079	N8041	N8079	B8541	B8579	M9541	M9579	6	
5-6"	F860MK	G8, G18, G22, G23	F860M		2	F860S				FA400	7110	7240		8110	8240		9110	9240	H7060	H7079	N8060	N8079	B8560	B8579	M9560	M9579	8	
KIT NOTES: G8. Power Steering Models Only. G18. See Brake Lines Section. G22. May Require End Links on Models Equipped with Factory Sway Bars. See Ford Accessories. G23. Vehicles with Diesel Engine will Require Front Fitted Leafs. Vehicles with Extra Weight may Require Fitted Leafs. See Leaf Springs Section.																												
<b>86-98 F-350 4WD (Mono-Beam) Kit</b>											<b>For Rear Towing Package with Blocks &amp; U-Bolts</b>																	
3-4"	F840MK3	G8, G18, G22, G23	F840MH		2	F840S				FA400	7110	7240		8110	8240		9110	9240	H7041	H7079	N8041	N8079	B8541	B8579	M9541	M9579	6	
5-6"	F860MK3	G8, G18, G22, G23	F860MH		2	F860S				FA400	7110	7240		8110	8240		9110	9240	H7060	H7079	N8060	N8079	B8560	B8579	M9560	M9579	8	
KIT NOTES: G8. Power Steering Models Only. G18. See Brake Lines Section. G22. May Require End Links on Models Equipped with Factory Sway Bars. See Ford Accessories. G23. Vehicles with Diesel Engine will Require Front Fitted Leafs. Vehicles with Extra Weight may Require Fitted Leafs. See Leaf Springs Section.																												
<b>86-98 F-350 4WD (Mono-Beam) System</b>											<b>With Replacement Rear Springs</b>																	
3-4"	F840MKS	G8, G18, G22, G23	F840MS		2	F840S	2	FR54S		FA400	7110	7240		8110	8240		9110	9240	H7041	H7079	N8041	N8079	B8541	B8579	M9541	M9579	6	
5-6"	F860MKS	G8, G18, G22, G23	F860MS		2	F860S	2	FR56S		FA400	7110	7240		8110	8240		9110	9240	H7060	H7079	N8060	N8079	B8560	B8579	M9560	M9579	8	
KIT NOTES: G8. Power Steering Models Only. G18. See Brake Lines Section. G22. May Require End Links on Models Equipped with Factory Sway Bars. See Ford Accessories. G23. Vehicles with Diesel Engine will Require Front Fitted Leafs. Vehicles with Extra Weight may Require Fitted Leafs. See Leaf Springs Section.																												
<b>80-85 F-350 INDEPENDENT FRONT SUSPENSION 4WD (IFS)</b>											<b>NOTE: ALL SHOCKS MUST BE ORDERED SEPARATELY.</b>																	
<b>80-85 F-350 (IFS) 4WD Kit</b>											<b>302 or 351 Engine with Front Add-A-Leafs</b>																	
1.5-2"	F35G	G1							F35G		7140	7240		8110	8240		9110	9240	H7054	H7058	N8054	N8058	B8554	B8558	M9554	M9558	4	
KIT NOTES: G1. Oversized Camber / Caster Shims are Required (See Ford Accessories Section).																												
<b>80-85 F-350 (IFS) 4WD Kit</b>											<b>460 or Diesel Engine with Front Add-A-Leafs</b>																	
1.5-2"	F46D	G1							F46D		7140	7240		8140	8240		9140	9240	H7054	H7058	N8054	N8058	B8554	B8558	M9554	M9558	4	
KIT NOTES: G1. Oversized Camber / Caster Shims are Required (See Ford Accessories Section).																												
<b>80-85 F-350 (IFS) 4WD Kit</b>											<b>Standard Brackets with Blocks &amp; U-Bolts</b>																	
4"	F840TK	G8, G18, G22, G23	F840T		2	F840S				FA400	7140	7240		8140	8240		9140	9240	H7055	H7060	N8055	N8060	B8555	B8560	M9555	M9560	6	
6"	F860TK	G8, G18, G22, G23	F860T		2	F860S				FA400	7140	7240		8140	8240		9140	9240	H7056	H7060	N8056	N8060	B8556	B8560	M9556	M9560	8	
KIT NOTES: G8. Power Steering Models Only. G18. See Brake Lines Section. G22. May Require End Links on Models Equipped with Factory Sway Bars. See Ford Accessories. G23. Vehicles with Diesel Engine will Require Front Fitted Leafs. Vehicles with Extra Weight may Require Fitted Leafs. See Leaf Springs Section.																												
<b>80-85 F-350 (IFS) 4WD Kit</b>											<b>For Rear Towing Package with Blocks &amp; U-Bolts</b>																	

FORD

FORD

LIFT	Quick Kit Reference	KIT NOTES	Component Box (Requires 1 Of Each)	Front Springs		Rear Springs		Add-A-Leafs	Steering Correction (Order 1 Each)	Steering Stabilizers						HYDRO Shocks		NITRO Shocks		BLACK MAX		M95 Shocks		Labor Hours			
				Qty	Part #	Qty	Part #			White		Black		Silver		White		Black		Silver							
				OEM	Single	Dual	OEM			Single	Dual	OEM	Single	Dual	Front	Rear	Front	Rear	Front	Rear	Front	Rear					
4"	F840TK3	G8, G18, G22, G23	F840TH	2	F840S				FA400		7140	7240		8140	8240		9140	9240	H7055	H7060	N8055	N8060	B8555	B8560	M9555	M9560	6
6"	F860TK3	G8, G18, G22, G23	F860TH	2	F860S				FA400		7140	7240		8140	8240		9140	9240	H7056	H7060	N8056	N8060	B8556	B8560	M9556	M9560	8

KIT NOTES: G8. Power Steering Models Only. G18. See Brake Lines Section. G22. May Require End Links on Models Equipped with Factory Sway Bars. See Ford Accessories. G23. Vehicles with Diesel Engine will Require Front Fitted Leafs. Vehicles with Extra Weight may Require Fitted Leafs. See Leaf Springs Section.

80-85 F-350 (IFS) 4WD System			Standard Brackets with Replacement Rear Springs																									
4"	F840TKS	G8, G18, G22, G23	F840TS	2	F840S	2	FR54S			FA400		7140	7240		8140	8240		9140	9240	H7055	H7060	N8055	N8060	B8555	B8560	M9555	M9560	6
6"	F860TKS	G8, G18, G22, G23	F860TS	2	F860S	2	FR56S			FA400		7140	7240		8140	8240		9140	9240	H7056	H7060	N8056	N8060	B8556	B8560	M9556	M9560	8

KIT NOTES: G8. Power Steering Models Only. G18. See Brake Lines Section. G22. May Require End Links on Models Equipped with Factory Sway Bars. See Ford Accessories. G23. Vehicles with Diesel Engine will Require Front Fitted Leafs. Vehicles with Extra Weight may Require Fitted Leafs. See Leaf Springs Section.

**80-96 F-350 2WD WITH DIESEL OR 460 ENGINES** **NOTE: ALL SHOCKS MUST BE ORDERED SEPARATELY.**

80-96 F-350 2WD Kit			With Blocks & U-Bolts &/or Add-A-Leafs																									
3"	184F2K	G1, G8	184F2	1	184				FA400											H7054	H7058	N8054	N8058	B8554	B8558	M9554	M9558	6
5"	186F2K	G1, G8	186F2	1	186				FA400											H7055	H7041	N8055	N8041	B8555	B8541	M9555	M9541	6

KIT NOTES: G1. Oversized Camber / Caster Shims are Required (See Ford Accessories Section). G8. Power Steering Models Only.

**79 F-350 LOW BOY 4WD** **NOTE: ALL SHOCKS MUST BE ORDERED SEPARATELY.**

79 F-350 Low Boy 4WD Kit			Front Add-A-Leafs																									
1.5-2"	F46D							F46D	---	---		7110	7220		8110	8220		9110	9220									4

**83-97 RANGER 4WD** **NOTE: ALL SHOCKS MUST BE ORDERED SEPARATELY.**

90-97 Ranger XLT 4WD Kit			6-Cylinder Engine with Add-A-Leafs																									
1.5-2"	132XK	G1		1	132X			R3135				7150	7250		8150	8250		9150	9250	H7052	H7060	N8052	N8060	B8552	B8560	M9552	M9560	4

KIT NOTES: G1. Oversized Camber / Caster Shims are Required (See Ford Accessories Section).

90-97 Ranger XLT 4WD System			6-Cylinder Engine with Replacement Rear Springs																									
1.5-2"	132XKS	G1, G10, G27	132XRS	1	132X	2	FR34S					7150	7250		8150	8250		9150	9250	H7052	H7060	N8052	N8060	B8552	B8560	M9552	M9560	4

KIT NOTES: G1. Oversized Camber / Caster Shims are Required (See Ford Accessories Section). G10. The Factory Block is Removed. G27. May Require (2) # HS25 for Alignment & Leveling Aid with 4.0 Liter Engine. May Require End Links.

90-97 Ranger 4WD Kit			4-Cylinder Engine with Add-A-Leafs																									
1.5-2"	132K	G1		1	132			R3135				7150	7250		8150	8250		9150	9250	H7052	H7060	N8052	N8060	B8552	B8560	M9552	M9560	4

KIT NOTES: G1. Oversized Camber / Caster Shims are Required (See Ford Accessories Section).

87-89 Ranger STX 4WD Kit			With Add-A-Leafs																									
1.5-2"	132XK	G1		1	132X			R3135				7150	7250		8150	8250		9150	9250	H7052	H7060	N8052	N8060	B8552	B8560	M9552	M9560	4

KIT NOTES: G1. Oversized Camber / Caster Shims are Required (See Ford Accessories Section).

87-89 Ranger STX 4WD System			With Replacement Rear Springs																									
1.5-2"	132XKS	G1, G10	132XRS	1	132X	2	FR34S					7150	7250		8150	8250		9150	9250	H7052	H7060	N8052	N8060	B8552	B8560	M9552	M9560	4

KIT NOTES: G1. Oversized Camber / Caster Shims are Required (See Ford Accessories Section). G10. The Factory Block is Removed.

83-89 Ranger 4WD Kit			All (Except Supercab with 2.9 Liter) with Add-A-Leafs																									
1.5-2"	132K	G1		1	132			R3135				7150	7250		8150	8250		9150	9250	H7052	H7060	N8052	N8060	B8552	B8560	M9552	M9560	4

KIT NOTES: G1. Oversized Camber / Caster Shims are Required (See Ford Accessories Section).

83-89 Ranger 4WD System			All (Except Supercab with 2.9 Liter) with Replacement Rear Springs																									
1.5-2"	132KS	G1, G10	132RS	1	132	2	FR34S					7150	7250		8150	8250		9150	9250	H7052	H7060	N8052	N8060	B8552	B8560	M9552	M9560	4

KIT NOTES: G1. Oversized Camber / Caster Shims are Required (See Ford Accessories Section). G10. The Factory Block is Removed.

83-89 Ranger Supercab 4WD Kit			2.9L with Add-A-Leafs																									
1.5-2"	132XK	G1		1	132X			R3135				7150	7250		8150	8250		9150	9250	H7052	H7060	N8052	N8060	B8552	B8560	M9552	M9560	4

KIT NOTES: G1. Oversized Camber / Caster Shims are Required (See Ford Accessories Section).

83-89 Ranger Supercab 4WD System			2.9 Liter with Replacement Rear Springs																									
1.5-2"	132XKS	G1, G10	132XRS	1	132X	2	FR34S					7150	7250		8150	8250		9150	9250	H7052	H7060	N8052	N8060	B8552	B8560	M9552	M9560	4

KIT NOTES: G1. Oversized Camber / Caster Shims are Required (See Ford Accessories Section). G10. The Factory Block is Removed.

83-97 Ranger 4WD Kit			Heavy-Duty Brackets with Blocks & U-Bolts &/or Add-A-Leafs																								
4"	134RHK	G8, G18, G27	134RH	1	134				FA400		7150	7250		8150	8250		9150	9250	H7054	H7060	N8054	N8060	B8554	B8560	M9554	M9560	6
6"	136RHK	G8, G18, G27	136RH	1	136				FA400		7150	7250		8150	8250		9150	9250	H7055	H7060	N8055	N8060	B8555	B8560	M9555	M9560	6

KIT NOTES: G8. Power Steering Models Only. G18. See Brake Lines Section. G27. May Require (2) # HS25 for Alignment & Leveling Aid. May Require End Links.

83-97 Ranger 4WD System			Heavy-Duty Brackets with Replacement Rear Springs																									
4"	134RHKS	G8, G10, G18, G27	134RHS	1	134	2	FR34S			FA400		7150	7250		8150	8250		9150	9250	H7054	H7060	N8054	N8060	B8554	B8560	M9554	M9560	6
6"	136RHKS	G8, G18, G27	136RHS	1	136	2	FR34S			FA400		7150	7250		8150	8250		9150	9250	H7055	H7060	N8055	N8060	B8555	B8560	M9555	M9560	6

KIT NOTES: G8. Power Steering Models Only. G10. The Factory Block is Removed. G18. See Brake Lines Section. G27. May Require (2) # HS25 for Alignment & Leveling Aid with 4.0 Liter Engine. May Require End Links.

83-97 Ranger 4WD Kit			Class II Brackets & Radius Arms with Blocks & U-Bolts												
----------------------	--	--	---	--	--	--	--	--	--	--	--	--	--	--	--



LIFT	Quick Kit	KIT NOTES	Component Box		Front Springs		Rear Springs		Add-A-Leafs	Steering Correction	Steering Stabilizers						HYDRO Shocks		NITRO Shocks		BLACK MAX		M95 Shocks		Labor			
			(Requires 1 Of Each)		Qty	Part #	Qty	Part #			White		Black		Silver		White		White		Black		Silver					
											OEM	Single	Dual	OEM	Single	Dual	OEM	Single	Dual	Front	Rear	Front	Rear	Front		Rear	Front	Rear
4"	234RHK-A	G8, G18, G27	234RH+RA135		1	134				Included		7150	7250		8150	8250		9150	9250	H7054	H7060	N8054	N8060	B8554	B8560	M9554	M9560	7
6"	236RHK-A	G8, G18, G27	236RH+RA135		1	136				Included		7150	7250		8150	8250		9150	9250	H7055	H7060	N8055	N8060	B8555	B8560	M9555	M9560	7

KIT NOTES: G8. Power Steering Models Only. G18. See Brake Lines Section. G27. May Require (2) # HS25 for Alignment & Leveling Aid with 4.0 Liter Engine.

83-97 Ranger 4WD System		Class II Brackets & Radius Arms with Replacement Rear Springs																										
4"	234RHKS-A	G8, G10, G18, G27	234RHS+RA135		1	134	2	FR34S		Included		7150	7250		8150	8250		9150	9250	H7054	H7060	N8054	N8060	B8554	B8560	M9554	M9560	7
6"	236RHKS-A	G8, G18, G27	236RHS+RA135		1	136	2	FR34S		Included		7150	7250		8150	8250		9150	9250	H7055	H7060	N8055	N8060	B8555	B8560	M9555	M9560	7

KIT NOTES: G8. Power Steering Models Only. G10. The Factory Block is Removed. G18. See Brake Lines Section. G27. May Require (2) # HS25 for Alignment & Leveling Aid with 4.0 Liter Engine.

**83-97 RANGER 2WD** **NOTE: ALL SHOCKS MUST BE ORDERED SEPARATELY.**

90-97 Ranger 2WD Kit		2.3, 2.9 & 3.0 Liter Engines with Add-A-Leafs																										
1.5-2"	132K	G1			1	132			R3135			7150	7250		8150	8250		9150	9250	H7052	H7058	N8052	N8058	B8552	B8558	M9552	M9558	4

KIT NOTES: G1. Oversized Camber / Caster Shims are Required (See Ford Accessories Section).

90-97 Ranger 2WD Kit		4.0 Liter Engines with Add-A-Leafs																										
1.5-2"	132XK	G1			1	132X			R3135			7150	7250		8150	8250		9150	9250	H7052	H7058	N8052	N8058	B8552	B8558	M9552	M9558	4

KIT NOTES: G1. Oversized Camber / Caster Shims are Required (See Ford Accessories Section).

83-89 Ranger 2WD Kit		All (Except Supercab with 2.9 Liter) with Add-A-Leafs																										
1.5-2"	132K	G1			1	132			R3135			7150	7250		8150	8250		9150	9250	H7052	H7058	N8052	N8058	B8552	B8558	M9552	M9558	4

KIT NOTES: G1. Oversized Camber / Caster Shims are Required (See Ford Accessories Section).

83-89 Ranger Supercab 2WD Kit		2.9 Liter with Add-A-Leafs																										
1.5-2"	132XK	G1			1	132X			R3135			7150	7250		8150	8250		9150	9250	H7052	H7058	N8052	N8058	B8552	B8558	M9552	M9558	4

KIT NOTES: G1. Oversized Camber / Caster Shims are Required (See Ford Accessories Section).

83-97 Ranger 2WD Kit		With Blocks & U-Bolts																										
6"	136R2K	G8, G18, G27	136R2		1	136				FA400		7150	7250		8150	8250		9150	9250	H7055	H7060	N8055	N8060	B8555	B8560	M9555	M9560	6

KIT NOTES: G8. Power Steering Models Only. G18. See Brake Lines Section. G27. May Require (2) # HS25 for Alignment & Leveling Aid with 4.0 Liter Engine. May Require End Links.

83-97 Ranger 2WD Kit		Class II Brackets & Radius Arms with Blocks & U-Bolts																										
6"	236R2K-A	G8, G18, G27	236R2+RA235		1	136				Included		7150	7250		8150	8250		9150	9250	H7055	H7060	N8055	N8060	B8555	B8560	M9555	M9560	7

KIT NOTES: G8. Power Steering Models Only. G18. See Brake Lines Section. G27. May Require (2) # HS25 for Alignment & Leveling Aid with 4.0 Liter Engine.

83-97 Ranger 2WD System		Class II Brackets & Radius Arms with Replacement Rear Springs																										
6"	236R2KS-A	G8, G18, G27	236R2S+RA235		1	136	2	FR34S		Included		7150	7250		8150	8250		9150	9250	H7055	H7060	N8055	N8060	B8555	B8560	M9555	M9560	7

KIT NOTES: G8. Power Steering Models Only. G18. See Brake Lines Section. G27. May Require (2) # HS25 for Alignment & Leveling Aid with 4.0 Liter Engine.

**84-90 BRONCO II 4WD** **NOTE: ALL SHOCKS MUST BE ORDERED SEPARATELY.**

83-90 Bronco II 4WD Kit		Heavy-Duty Brackets Blocks & U-Bolts &/or Add-A-Leafs																										
1.5-2"	132K	G1, G2			1	132			R3135			7150	7250		8150	8250		9150	9250	H7052	H7058	N8052	N8058	B8552	B8558	M9552	M9558	4
4"	134BHK	G2, G8, G18, G27	134BH		1	134				FA400		7150	7250		8150	8250		9150	9250	H7054	H7058	N8054	N8058	B8554	B8558	M9554	M9558	6
6"	136BHK	G2, G8, G18, G27	136BH		1	136				FA400		7150	7250		8150	8250		9150	9250	H7055	H7060	N8055	N8060	B8555	B8560	M9555	M9560	6

KIT NOTES: G1. Oversized Camber / Caster Shims are Required (See Ford Accessories Section). G2. On 85-90 Bronco II's Equipped with a 'Tulip-Type' Rear Drive Shaft, the Drive Shaft must be Changed when Lifted 2" or More. G8. Power Steering Models Only. G18. See Brake Lines Section. G27. May Require (2) # HS25 for Alignment & Leveling Aid with 4.0 Liter Engine. May Require End Links.

84-90 Bronco II 4WD System		Heavy-Duty Brackets with Replacement Rear Springs																										
6"	136BHKS	G2, G8, G18, G27	136BHS		1	136	2	FR36S		FA400		7150	7250		8150	8250		9150	9250	H7055	H7060	N8055	N8060	B8555	B8560	M9555	M9560	6

KIT NOTES: G2. On 85-90 Bronco II's Equipped with a 'Tulip-Type' Rear Drive Shaft, the Drive Shaft must be Changed when Lifted 2" or More. G8. Power Steering Models Only. G9. This Lift also Includes 2" Blocks. G18. See Brake Lines Section. G27. May Require (2) # HS25 for Alignment & Leveling Aid with 4.0 Liter Engine. May Require End Links.

84-90 Bronco II 4WD Kit		Class II Brackets & Radius Arms with Blocks & U-Bolts																										
6"	236BHK-A	G2, G8, G18, G27	236BH+RA135		1	136				Included		7150	7250		8150	8250		9150	9250	H7055	H7060	N8055	N8060	B8555	B8560	M9555	M9560	7

KIT NOTES: G2. On 85-90 Bronco II's Equipped with a 'Tulip-Type' Rear Drive Shaft, the Drive Shaft must be Changed when Lifted 2" or More. G8. Power Steering Models Only. G18. See Brake Lines Section. G27. May Require (2) # HS25 for Alignment & Leveling Aid with 4.0 Liter Engine.

84-90 Bronco II 4WD System		Class II Brackets & Radius Arms with Replacement Rear Springs																										
4"	234BHKS-A	G2, G8, G18, G27	234BHS+RA135		1	134	2	FR34S		Included		7150	7250		8150	8250		9150	9250	H7054	H7058	N8054	N8058	B8554	B8558	M9554	M9558	7
6"	236BHKS-A	G2, G8, G18, G27	236BHS+RA135		1	136	2	FR36S		Included		7150	7250		8150	8250		9150	9250	H7055	H7060	N8055	N8060	B8555	B8560	M9555	M9560	7

KIT NOTES: G2. On 85-90 Bronco II's Equipped with a 'Tulip-Type' Rear Drive Shaft, the Drive Shaft must be Changed when Lifted 2" or More. G8. Power Steering Models Only. G18. See Brake Lines Section. G27. May Require (2) # HS25 for Alignment & Leveling Aid with 4.0 Liter Engine.

**90-94 EXPLORER 4WD (2 DOOR & 4 DOOR)** **NOTE: ALL SHOCKS MUST BE ORDERED SEPARATELY.**

90-94 Explorer 4WD (2 Door & 4 Door) Kit		With Add-A-Leafs																										
1.5-2"	132EXK	G1			1	132X			R225			7150	7250		8150	8250		9150	9250	H7052	H7034	N8052	N8034	B8552	B8534	M9552	M9534	4

KIT NOTES: G1. Oversized Camber / Caster Shims are Required (See Ford Accessories Section).

# HONDA

# HONDA

LIFT	Quick Kit Reference	KIT NOTES	Component Box (Requires 1 of Each)	Front Springs		Rear Springs		Add-A- Leafs	Steering Correction (Order 1 Each)	Steering Stabilizers						HYDRO Shocks		NITRO Shocks		BLACK MAX		M95 Shocks		Labor Hours		
				Qty	Part #	Qty	Part #			White		Black		Silver		White		White		Black		Silver				
	OEM			Single	Dual	OEM	Single			Dual	OEM	Single	Dual	Front	Rear	Front	Rear	Front	Rear	Front	Rear	Front	Rear			
<b>06-10 HONDA RIDGELINE 4WD</b>																										
<b>06-10 Honda Ridgeline 4WD Kit</b>																										
			Front & Rear Metal Strut Spacers (Includes Front Swar Bar End Links)																							
2"	HR20MS		HR20MS																							4
KIT NOTES: Installs Above Strut Assembly. HR20MS Includes Sway Bar End Links.																										

**NOTE: ALL SHOCKS MUST BE ORDERED SEPARATELY**

# INTERNATIONAL

# INTERNATIONAL

LIFT	Quick Kit Reference	KIT NOTES	Component Box (Requires 1 of Each)	Front Springs		Rear Springs		Add-A- Leafs	Steering Correction (Order 1 Each)	Steering Stabilizers						HYDRO Shocks		NITRO Shocks		BLACK MAX		M95 Shocks		Labor Hours
				Qty	Part #	Qty	Part #			White		Black		Silver		White		White		Black		Silver		
	OEM			Single	Dual	OEM	Single			Dual	OEM	Single	Dual	Front	Rear	Front	Rear	Front	Rear	Front	Rear	Front	Rear	
<b>72-82 SCOUT 4WD</b>																								
<b>72-82 Scout II, Terra, Traveler 4WD System</b>																								
			With FULL-Height Replacement Springs																					
2"	S20K	I3	S24	2	S20FS	2	S20RS		SA40		7110		8110		9110	H7055	H7058	N8055	N8058	B8555	B8558	M9555	M9558	6
4"	S40K	I3	S24	2	S40FS	2	S40RS		SA40		7110		8110		9110	H7055	H7058	N8055	N8058	B8555	B8558	M9555	M9558	6
KIT NOTES: I3. Power Steering Models Only.																								

**NOTE: ALL SHOCKS MUST BE ORDERED SEPARATELY**

# ISUZU

# ISUZU

LIFT	Quick Kit Reference	KIT NOTES	Component Box (Requires 1 of Each)	Front Springs		Rear Springs		Add-A- Leafs	Steering Correction (Order 1 Each)	Steering Stabilizers						HYDRO Shocks		NITRO Shocks		BLACK MAX		M95 Shocks		Labor Hours	
				Qty	Part #	Qty	Part #			White		Black		Silver		White		White		Black		Silver			
	OEM			Single	Dual	OEM	Single			Dual	OEM	Single	Dual	Front	Rear	Front	Rear	Front	Rear	Front	Rear	Front	Rear		
<b>05-08 ISUZU I-SERIES 4WD (TORSION BAR)</b>																									
<b>05-08 Isuzu i-Series 4WD Kit</b>																									
			Kit with Rear Add-A-Leafs																						
4"	CC409K	K24	CC409					RCC25								H7040	H7084	N8040	N8084	B8540	B8584	—	—	M9584	8
KIT NOTES: K24. Can NOT Re-Use OEM Wheels. REQUIRES 4.75" Back Spacing on Wheels.																									
<b>05-08 Isuzu i-Series 4WD System</b>																									
			Kit with Rear Springs																						
4"	CC409KS	K24	CC409			2	CCR25S									H7040	H7084	N8040	N8084	B8540	B8584	—	—	M9584	8
KIT NOTES: K24. Can NOT Re-Use OEM Wheels. REQUIRES 4.75" Back Spacing on Wheels.																									

HONDA, INTL., ISUZU

HONDA, INTL., ISUZU

LIFT	Quick Kit Reference	KIT NOTES	Component Box (Requires 1 of Each)	Front Springs		Rear Springs		Steering Correction (Order 1 Each)	Steering Stabilizers				HYDRO Shocks		NITRO Shocks		BLACK MAX		M95 Shocks		Labor Hours		
				Qty	Part #	Qty	Part #		White		Black		Silver		FOX		White		Black			Silver	
									OEM	Dual	OEM	Dual	OEM	Dual	OEM	Dual	Front	Rear	Front	Rear		Front	Rear
<b>2018 WRANGLER JL 4 DOOR 4WD</b>																							
<b>POLYURETHANE VALUE KITS</b>																							
<b>NOTE: SHOCKS &amp; STABILIZERS ORDERED SEPARATELY</b>																							
<b>2018 Wrangler JL 4 Door 4WD</b>																							
<b>Polyurethane Front Spacers</b>																							
3/4"	JLFPS75		JLFPS75						7008	7208 <sup>(B)</sup>	8008	8208 <sup>(B)</sup>	9008	9208 <sup>(B)</sup>							2		
<b>2018 Wrangler JL 4 Door 4WD</b>																							
<b>Polyurethane Rear Spacers</b>																							
3/4"	JLRPS75		JLRPS75						7008	7208 <sup>(B)</sup>	8008	8208 <sup>(B)</sup>	9008	9208 <sup>(B)</sup>							2		
<b>2018 Wrangler JL 4 Door 4WD</b>																							
<b>2" Front &amp; 2" Rear Kit - Polyurethane Spacers</b>																							
2"	JL20		JL20						7008	7208 <sup>(B)</sup>	8008	8208 <sup>(B)</sup>	9008	9208 <sup>(B)</sup>							3		
(B). Boot Not Included Due to Clearance Issues.																							
<b>2018 WRANGLER JL 4 DOOR 4WD (NON-RUBICON)</b>																							
<b>DUAL-RATE LONG TRAVEL SERIES</b>																							
<b>2018 Wrangler JL 4 Door 4WD (NON-RUBICON)</b>																							
<b>Includes Front &amp; Rear DUAL-RATE LONG TRAVEL Coil Springs &amp; Shocks</b>																							
1-1.5"	JL15BPBLT	E31	JL15BPBLT	1	Included	1	Included		7008	7208 <sup>(B)</sup>	8008	8208 <sup>(B)</sup>	9008	9208 <sup>(B)</sup>					Included	Included		4	
KIT NOTES: NEW DUAL-RATE LONG TRAVEL Coil Springs & Shocks. Includes (4) Black MAX Shocks.																							
1-1.5"	JL15BPMLT	E31	JL15BPMLT	1	Included	1	Included		7008	7208 <sup>(B)</sup>	8008	8208 <sup>(B)</sup>	9008	9208 <sup>(B)</sup>							Included	Included	4
KIT NOTES: NEW DUAL-RATE LONG TRAVEL Coil Springs & Shocks. Includes (4) M95 Shocks.																							
(B). Boot Not Included Due to Clearance Issues.																							
<b>2018 WRANGLER JL 4 DOOR 4WD (RUBICON)</b>																							
<b>DUAL-RATE LONG TRAVEL SERIES</b>																							
<b>2018 Wrangler JL 4 Door 4WD (RUBICON)</b>																							
<b>Includes Front &amp; Rear DUAL-RATE LONG TRAVEL Coil Springs &amp; Shocks</b>																							
1-1.5"	JL15RBPBLT	E31	JL15RBPBLT	1	Included	1	Included		7008	7208 <sup>(B)</sup>	8008	8208 <sup>(B)</sup>	9008	9208 <sup>(B)</sup>					Included	Included		4	
KIT NOTES: NEW DUAL-RATE LONG TRAVEL Coil Springs & Shocks. Includes (4) Black MAX Shocks.																							
1-1.5"	JL15RBPMLT	E31	JL15RBPMLT	1	Included	1	Included		7008	7208 <sup>(B)</sup>	8008	8208 <sup>(B)</sup>	9008	9208 <sup>(B)</sup>							Included	Included	4
KIT NOTES: NEW DUAL-RATE LONG TRAVEL Coil Springs & Shocks. Includes (4) M95 Shocks.																							
(B). Boot Not Included Due to Clearance Issues.																							
<b>2018 WRANGLER JL 4 DOOR 4WD (NON-RUBICON)</b>																							
<b>DUAL-RATE LONG TRAVEL SERIES</b>																							
<b>2018 Wrangler JL 4 Door 4WD (NON-RUBICON)</b>																							
<b>Includes Front &amp; Rear DUAL-RATE LONG TRAVEL Coil Springs &amp; Shocks</b>																							
2-2.5"	JL25BPBLT	E31	JL25BPBLT	1	Included	1	Included		7008	7208 <sup>(B)</sup>	8008	8208 <sup>(B)</sup>	9008	9208 <sup>(B)</sup>					Included	Included		4	
KIT NOTES: NEW DUAL-RATE LONG TRAVEL Coil Springs & Shocks. Includes (4) Black MAX Shocks.																							
2-2.5"	JL25BPMLT	E31	JL25BPMLT	1	Included	1	Included		7008	7208 <sup>(B)</sup>	8008	8208 <sup>(B)</sup>	9008	9208 <sup>(B)</sup>							Included	Included	4
KIT NOTES: NEW DUAL-RATE LONG TRAVEL Coil Springs & Shocks. Includes (4) M95 Shocks.																							
(B). Boot Not Included Due to Clearance Issues.																							
<b>2018 WRANGLER JL 4 DOOR 4WD (RUBICON)</b>																							
<b>DUAL-RATE LONG TRAVEL SERIES</b>																							
<b>2018 Wrangler JL 4 Door 4WD (RUBICON)</b>																							
<b>Includes Front &amp; Rear DUAL-RATE LONG TRAVEL Coil Springs &amp; Shocks</b>																							
2-2.5"	JL25RBPBLT	E31	JL25RBPBLT	1	Included	1	Included		7008	7208 <sup>(B)</sup>	8008	8208 <sup>(B)</sup>	9008	9208 <sup>(B)</sup>					Included	Included		4	
KIT NOTES: NEW DUAL-RATE LONG TRAVEL Coil Springs & Shocks. Includes (4) Black MAX Shocks.																							
2-2.5"	JL25RBPMLT	E31	JL25RBPMLT	1	Included	1	Included		7008	7208 <sup>(B)</sup>	8008	8208 <sup>(B)</sup>	9008	9208 <sup>(B)</sup>							Included	Included	4
KIT NOTES: NEW DUAL-RATE LONG TRAVEL Coil Springs & Shocks. Includes (4) M95 Shocks.																							
(B). Boot Not Included Due to Clearance Issues.																							
<b>2018 WRANGLER JL 4 DOOR 4WD (NON-RUBICON)</b>																							
<b>DUAL-RATE LONG TRAVEL SERIES</b>																							
<b>2018 Wrangler JL 4 Door 4WD (NON-RUBICON)</b>																							
<b>Includes Front &amp; Rear DUAL-RATE LONG TRAVEL Coil Springs &amp; Shocks</b>																							
3.5-4"	JL40BPBLT	E31	JL40BPBLT	1	Included	1	Included		7008	7208 <sup>(B)</sup>	8008	8208 <sup>(B)</sup>	9008	9208 <sup>(B)</sup>					Included	Included		5	
KIT NOTES: NEW DUAL-RATE LONG TRAVEL Coil Springs. Includes Front & Rear Lower Control Arms, Adjustable Front Track Bar, and (4) Black MAX Shocks.																							
3.5-4"	JL40BPMLT	E31	JL40BPMLT	1	Included	1	Included		7008	7208 <sup>(B)</sup>	8008	8208 <sup>(B)</sup>	9008	9208 <sup>(B)</sup>							Included	Included	5
KIT NOTES: NEW DUAL-RATE LONG TRAVEL Coil Springs. Includes Front & Rear Lower Control Arms, Adjustable Front Track Bar, and (4) M95 Shocks.																							
<b>2018 WRANGLER JL 4 DOOR 4WD (RUBICON)</b>																							
<b>DUAL-RATE LONG TRAVEL SERIES</b>																							
<b>2018 Wrangler JL 4 Door 4WD (RUBICON)</b>																							
<b>Includes Front &amp; Rear DUAL-RATE LONG TRAVEL Coil Springs &amp; Shocks</b>																							
3.5-4"	JL40RBPBLT	E31	JL40RBPBLT	1	Included	1	Included		7008	7208 <sup>(B)</sup>	8008	8208 <sup>(B)</sup>	9008	9208 <sup>(B)</sup>					Included	Included		5	
KIT NOTES: NEW DUAL-RATE LONG TRAVEL Coil Springs. Includes Front & Rear Lower Control Arms, Adjustable Front Track Bar, and (4) Black MAX Shocks.																							
3.5-4"	JL40RBPMLT	E31	JL40RBPMLT	1	Included	1	Included		7008	7208 <sup>(B)</sup>	8008	8208 <sup>(B)</sup>	9008	9208 <sup>(B)</sup>							Included	Included	5
KIT NOTES: NEW DUAL-RATE LONG TRAVEL Coil Springs. Includes Front & Rear Lower Control Arms, Adjustable Front Track Bar, and (4) M95 Shocks.																							

**E31.** Heavy Duty Lower Links & Single Flex Bent Links Upgrade Available.  
 Front & Rear Lower **FLEX** Links with Currie Johnny Joints. Order **Part# JL24LLX**.  
 Front & Rear Heavy Duty Lower Links. Order **Part# JL24LL**.



LIFT	Quick Kit	KIT NOTES	Component Box (Requires 1 of Each)	Front Springs		Rear Springs		Steering Correction (Order 1 Each)	Steering Stabilizers				HYDRO Shocks		NITRO Shocks		BLACK MAX		M95 Shocks		Labor Hours		
				Qty	Part #	Qty	Part #		White	Black	Silver	FOX	White		Black		Silver						
	Reference			(Requires 1 of Each)	Qty	Part #	Qty		Part #	OEM	Dual	OEM	Dual	OEM	Dual	OEM	Dual	Front	Rear	Front		Rear	Front
<b>2018 WRANGLER JL ACCESSORIES</b>																							
Part #	Description										Lift	Part #	Description										Lift
JLFPS75	.75" Front Coil Spring Isolator Pads - Pair										3/4"	JL24LLX	Single Flex Front & Rear Lower Links with Currie Johnny Joints										1-4"
JLRPS75	.75" Rear Coil Spring Isolator Pads - Pair										3/4"	JLL24F-SX	Single Flex Front Lower Links with Currie Johnny Joints - Pair										1-4"
JL20PSF	2" Front Coil Spring Isolator Pads - Pair										2"	JLL24R-SX	Single Flex Rear Lower Links with Currie Johnny Joints - Pair										1-4"
JL20PSR	2" Rear Coil Spring Isolator Pads - Pair										2"	JLULF26-SX	Single Flex Front Upper Links - Pair										1-6"
JL24LL	Heavy Duty Front & Rear Lower Links										1-4"	JLULR26-SX	Single Flex Rear Upper Links - Pair										1-6"

\*Many more accessories - Available soon  
 \*LeDuc Series Bolt-On Coil Over Conversion - Available Soon



1-1.5" Dual Rate Long Travel



3.5-4" Dual Rate Long Travel



2-2.5" Dual Rate Long Travel

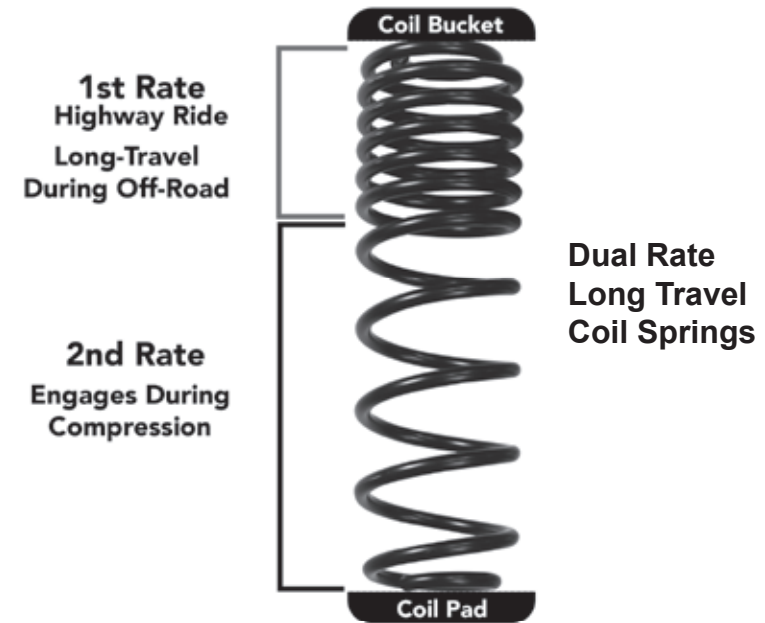



LIFT	Quick Kit Reference	KIT NOTES	Component Box (Requires 1 of Each)	Front Springs		Rear Springs		Steering Correction (Order 1 Each)	Steering Stabilizers				HYDRO Shocks		NITRO Shocks		BLACK MAX		M95 Shocks		Labor Hours
				Qty	Part #	Qty	Part #		White OEM	Black OEM	Silver OEM	FOX OEM	White Front	White Rear	Black Front	Black Rear	Silver Front	Silver Rear			
				Dual		Dual			Dual		Dual		Dual		Dual		Dual				

**07-18 WRANGLER JK / RUBICON 2 & 4 DOOR 2WD / 4WD** **NOTE: ALL SHOCKS MUST BE ORDERED SEPARATELY**

**LONG ARM SERIES - WITH UPPER & LOWER LINKS**

07-18 Wrangler JK / Rubicon 2 & 4 Door 2WD / 4WD Includes Front & Rear Coil Springs																									
4-5"	JK40LAK-SX	E24, E26, E27	JK46LA-SX + JK40LA	1	JK40FSR	1	JK40RSR	JA770	7003	7203 <sup>(B)</sup>	8003	8203 <sup>(B)</sup>	9003	9203 <sup>(B)</sup>	5004	5204	H7065	H7067	N8065	N8067	B8565	B8567	M9565	M9567	10
6-7"	JK60LAK-SX	E24, E26, E27	JK46LA-SX + JK60LA	1	JK60F	1	JK60R	JA770	7003	7203 <sup>(B)</sup>	8003	8203 <sup>(B)</sup>	9003	9203 <sup>(B)</sup>	5004	5204	H7075	H7087	N8075	N8087	B8575	B8587	M9575	M9587	10

KIT NOTES: Factory Skid Plates Can Not be Re-Used with Long Arm Series. E24. Due to Weight Differences 2 Door Models may Receive an Additional 1" of Lift Over 4 Door Models with the 6-7" Kit - New Front & Rear Drive Shaft is Required. OEM Wheel can be Used. E26. 2 Door Models will Require Rear CV Driveshaft. Part # CAM700 Highly Recommended for 2 Door Models for Optimum Pinion Adjustment. E27. For 12-17 Models - 3.5" Lifts & Up will Require Exhaust Spacers Part # JK36ESK.

(B). Boot Not Included Due to Clearance Issues.

**07-18 WRANGLER JK / RUBICON 2 & 4 DOOR 4WD**

**LeDuc Series Coil-Over Kits**

**07-18 Wrangler JK / Rubicon 2 & 4 Door 4WD Short Arm LeDuc Series Coil-Over Kit**

		Front Coil-Overs		Rear Coil-Overs																					
3.5-4.5"	JK40SLSK-SX	E29,	JK62FLSB + JK42RLSB + JK24LLX + JKFTBA717	1	JK62FLS	1	JK62RLS		7003	7203 <sup>(B)</sup>	8003	8203 <sup>(B)</sup>	9003	9203 <sup>(B)</sup>	5004	5204	---	---	---	---	---	---	---	---	12
5-6"	JK60SLSK-SX	E29, E30	JK62FLSB + JK62RLSB + JK24LLX + JKFTBA717	1	JK62FLS	1	JK62RLS		7003	7203 <sup>(B)</sup>	8003	8203 <sup>(B)</sup>	9003	9203 <sup>(B)</sup>	5004	5204	---	---	---	---	---	---	---	---	12

KIT NOTES: E29. Optional air bump stop kit available. Part# JKLSAB. E30. 2 Door Models require upper rear adjustable arms. Part# JKULR26-SX.

(B). Boot Not Included Due to Clearance Issues.

**07-18 Wrangler JK / Rubicon 2 & 4 Door 4WD Long Arm LeDuc Series Coil-Over Kit**

		Front Coil-Overs		Rear Coil-Overs																					
3.5-4.5"	JK44LLSK-SX	E26, E28, E29	JK62FLSB + JK42RLSB + JK46LA-SX + JKFTBA717	1	JK62FLS	1	JK62RLS	JA770	7003	7203 <sup>(B)</sup>	8003	8203 <sup>(B)</sup>	9003	9203 <sup>(B)</sup>	5004	5204	---	---	---	---	---	---	---	---	12
5-6"	JK64LLSK-SX	E26, E28, E29	JK62FLSB + JK62RLSB + JK46LA-SX + JKFTBA717	1	JK62FLS	1	JK62RLS	JA770	7003	7203 <sup>(B)</sup>	8003	8203 <sup>(B)</sup>	9003	9203 <sup>(B)</sup>	5004	5204	---	---	---	---	---	---	---	---	12

KIT NOTES: Factory Skid Plates Can Not be Re-Used with Long Arm Series. E26. 2 Door Models will Require Rear CV Driveshaft. E28. Driveshaft Modifications required. Maximum 4.5" backspacing is required. E29. Optional air bump stop kit available. Part# JKLSAB (Front), Part# JKLSABR (Rear).

(B). Boot Not Included Due to Clearance Issues.

**07-18 WRANGLER JK / RUBICON 2 & 4 DOOR 4WD**

**Wrangler JK Options**

Part #	Description	Lift	Part #	Description	Lift
JKFPS75	.75" Front Coil Spring Isolator Pads - Pair	3/4"	CAM700	Front Lower / Rear Upper Cam Bolt Kit	
JKRPS75	.75" Rear Coil Spring Isolator Pads - Pair	3/4"	JK2717B	Dual Load Balljoint Kit	
JK20PSF	2" Front Coil Spring Isolator Pads - Pair	2"	JK717DL	Rock Ready® Heavy Duty Drag Link	
JK20PSR	2" Rear Coil Spring Isolator Pads - Pair	2"	JK717TR	Rock Ready® Heavy Duty Tie Rod	
JKLL24F	Standard Front Lower Links - Pair	2-4"	JK717RC	Replacement Cartridge for Tie Rod / Drag Link	
JKLL24R	Standard Rear Lower Links - Pair	2-4"	JKFBL60	Stainless Steel Front Brake Line Set for 4-7" Lift	
JK24LLX	Single Flex Front and Rear Lower Links with Currie Johnny Joints - Set	2-5"	JKRBL60	Stainless Steel Rear Brake Line Set for 4-7" Lift	
JKLL24F-SX	Single Flex Front Lower Links with Currie Johnny Joints - Pair	2-5"	SBE126	Front Double Disconnect Swaybar Links	
JKLL24R-SX	Single Flex Rear Lower Links with Currie Johnny Joints - Pair	2-5"	JKFTBA717	Front Adjustable Track Bar	
JKULF26-SX	Single Flex Front Upper Links - Pair	2-7"	JKRTBA717	Rear Adjustable Track Bar	
JKULR26-SX	Single Flex Rear Upper Links - Pair	2-7"	TGSJK1	2007 - 2017 Jeep Wrangler JK / Tailgate Saver - Spare Tire Support Kit	
JK46LA-SX	Long Arm Upgrade Kit - Front and Rear Upper and Lower Links	3.5-6"	STRJK212	2007 - 2017 Jeep Wrangler JK / Spare Tire Relocation Kit	
JK36ESK	'12-'17 JK Exhaust Spacer (Will not fit JK and JKU models with 3.6L Engine)	4-6"	TGSSTR1	2007 - 2017 Jeep Wrangler JK / Tailgate Saver - Spare Tire Support & Spare Tire Relocation Combo Kit	
			JKLSAB	Air Bump Stop Kit (FRONT)	
			JKLSABR	Air Bump Stop Kit (REAR)	







LIFT	Quick Kit Reference	KIT NOTES	Component Box (Requires 1 of Each)	Front Springs		Rear Springs		Add-A-Leafs	Steering Correction (Order 1 Each)	Steering Stabilizers									HYDRO Shocks		NITRO Shocks		BLACK MAX		M95 Shocks		Labor Hours
				Qty	Part #	Qty	Part #			White			Black			Silver			White		White		Black		Silver		
				OEM	Single	Dual	OEM			Single	Dual	OEM	Single	Dual	OEM	Single	Dual	Front	Rear	Front	Rear	Front	Rear	Front	Rear	Front	
<b>ROCK READY® MONOLINEAR (SINGLE LEAF SPRING)</b>																											
<b>87-96 Wrangler YJ 4WD System *With Power Steering</b>																											
6"	YJ60MK	E4, E5, E6	YJ60M						JA750*	7009	7109	7200	8009	8109	8200	9009	9109	9200	H7061	H7088	N8061	N8088	B8561	B8588	M9561	M9558	10
KIT NOTES: E4. This Component Box Includes the 4 Monolinear Leaves. E5. Slip Yoke Eliminator Kit # RR231 & Replacement CV Driveshaft is REQUIRED. Available Direct from Skyjacker®. E6. # YJ5LK - 5th Link Traction Bar is Highly Recommended - See Jeep Accessories. *For Manual Steering Order JA850																											
<b>76-86 CJ5, CJ7, CJ8 4WD</b> <span style="float:right"><b>NOTE: ALL SHOCKS MUST BE ORDERED SEPARATELY</b></span>																											
<b>SPORT SERIES SYSTEMS</b>																											
<b>76-86 CJ5, CJ7, CJ8 WD System With Power Steering</b>																											
2.5"	J21BKH	E2, E12	J21BH	2	J20FSB	2	J20RSB			7001	7100	7200	8009	8100	8200	9009	9100	9200	Included	Included							
4"	J41BKH	E2, E12	J41BH	2	J40FSB	2	J40RSB		JA250	7001	7100	7200	8009	8100	8200	9009	9100	9200	Included	Included							
KIT NOTES: E2. Scrambler Models May Require an Additional Rear "Fitted" Leaf (Ordered Separately - See Leaf Springs Section). E12. See Brake Lines Section.																											
<b>76-86 CJ5, CJ7, CJ8 WD System With Manual Steering</b>																											
2.5"	J21BKH	E2, E12	J21BH	2	J20FSB	2	J20RSB			7001	7100	7200	8009	8100	8200	9009	9100	9200	Included	Included							
4"	J41BKH	E2, E12	J41BH	2	J40FSB	2	J40RSB		JA150	7001	7100	7200	8009	8100	8200	9009	9100	9200	Included	Included							
KIT NOTES: E2. Scrambler Models May Require an Additional Rear "Fitted" Leaf (Ordered Separately - See Leaf Springs Section). E12. See Brake Lines Section.																											
<b>SOFTRIDE® LEAF SPRING SYSTEMS</b>																											
<b>76-86 CJ5, CJ7, CJ8 4WD System With Power Steering</b>																											
2-2.5"	J20K	E2, E12	J24	2	J20FS	2	J20RS			7001	7100	7200	8009	8100	8200	9009	9100	9200	H7012	H7023	N8012	N8023	B8512	B8523	M9512	M9523	4
3.5-4"	J40K	E2, E12	J24	2	J40FS	2	J40RS		JA250	7001	7100	7200	8009	8100	8200	9009	9100	9200	H7023	H7058	N8023	N8058	B8523	B8558	M9523	M9558	4
KIT NOTES: E2. Scrambler Models May Require an Additional Rear "Fitted" Leaf (Ordered Separately - See Leaf Springs Section). E12. See Brake Lines Section.																											
<b>76-86 CJ5, CJ7, CJ8 4WD System With Manual Steering</b>																											
2-2.5"	J20K	E2, E12	J24	2	J20FS	2	J20RS			7001	7100	7200	8009	8100	8200	9009	9100	9200	H7012	H7023	N8012	N8023	B8512	B8523	M9512	M9523	4
3.5-4"	J40K	E2, E12	J24	2	J40FS	2	J40RS		JA150	7001	7100	7200	8009	8100	8200	9009	9100	9200	H7023	H7058	N8023	N8058	B8523	B8558	M9523	M9558	4
KIT NOTES: E2. Scrambler Models May Require an Additional Rear "Fitted" Leaf (Ordered Separately - See Leaf Springs Section). E12. See Brake Lines Section.																											
<b>72-75 CJ5, CJ7 4WD</b> <span style="float:right"><b>NOTE: ALL SHOCKS MUST BE ORDERED SEPARATELY</b></span>																											
<b>72-75 CJ5, CJ6 4WD System With Power Steering</b>																											
2-2.5"	J32K	E12	J34	2	J32FS	2	J32RS		JA552		7100	7200		8100	8200		9100	9200	H7023	H7023	N8023	N8023	B8523	B8523	M9523	M9523	4
3.5-4"	J34K	E12	J34	2	J34FS	2	J34RS		JA550		7100	7200		8100	8200		9100	9200	H7058	H7058	N8058	N8058	B8558	B8558	M9558	M9558	4
KIT NOTES: E12. See Brake Lines Section.																											
<b>72-75 CJ5, CJ6 4WD System With Manual Steering</b>																											
2-2.5"	J32K	E12	J34	2	J32FS	2	J32RS		JA652		7100	7200		8100	8200		9100	9200	H7023	H7023	N8023	N8023	B8523	B8523	M9523	M9523	4
3.5-4"	J34K	E12	J34	2	J34FS	2	J34RS		JA650		7100	7200		8100	8200		9100	9200	H7058	H7058	N8058	N8058	B8558	B8558	M9558	M9558	4
KIT NOTES: E12. See Brake Lines Section.																											
<b>55-71 CJ5, CJ6 4WD</b> <span style="float:right"><b>NOTE: ALL SHOCKS MUST BE ORDERED SEPARATELY</b></span>																											
<b>55-71 CJ5, CJ6 4WD System Includes Front &amp; Rear Springs</b>																											
2-2.5"	J32K	E12	J34	2	J32FS	2	J32RS				7100	7200		8100	8200		9100	9200	H7023	H7023	N8023	N8023	B8523	B8523	M9523	M9523	4
3.5-4"	J34K	E12	J34	2	J34FS	2	J34RS				7100	7200		8100	8200		9100	9200	H7058	H7058	N8058	N8058	B8558	B8558	M9558	M9558	4
KIT NOTES: E12. See Brake Lines Section.																											
<b>74-91 CHEROKEE / WAGONEER / GRAND WAGONEER 4WD - FULL-SIZE</b> <span style="float:right"><b>NOTE: ALL SHOCKS MUST BE ORDERED SEPARATELY</b></span>																											
<b>84-91 Cherokee / Wagoneer / Grand Wagoneer 4WD Kit With Rear Blocks</b>																											
3.5-4"	JP45K	E9, E12	JP45	2	JP40FS				JA350	7009			8009			9009			H7088	H7088	N8088	N8088	B8588	B8588	M9558	M9558	4
KIT NOTES: E9. Power Steering Models Only. E12. See Brake Lines Section.																											
<b>84-91 Cherokee / Wagoneer / Grand Wagoneer 4WD Kit Includes Front &amp; Rear Full Height Replacement Springs</b>																											
3.5-4"	JP45KS	E9, E12	JP45S	2	JP40FS	2	JP40RS		JA350	7009			8009			9009			H7088	H7088	N8088	N8088	B8588	B8588	M9558	M9558	4
KIT NOTES: E9. Power Steering Models Only. E12. See Brake Lines Section.																											
<b>74-83 Cherokee / Wagoneer 4WD Kit With Rear Blocks</b>																											
3.5-4"	JP40K	E9, E12	JP40	2	JP40FS				JA350	7005			8005			9005			H7088	H7088	N8088	N8088	B8588	B8588	M9558	M9558	4
KIT NOTES: E9. Power Steering Models Only. E12. See Brake Lines Section.																											
<b>76-83 Cherokee / Wagoneer 4WD System Includes Front &amp; Rear Full Height Replacement Springs</b>																											
3.5-4"	JP40KS	E9, E12	JP40S	2	JP40FS	2	JP40RS		JA350	7005			8005			9005			H7088	H7088	N8088	N8088	B8588	B8588	M9558	M9558	4
KIT NOTES: E9. Power Steering Models Only. E12. See Brake Lines Section.																											
<b>74-88 J10, J20 PICKUP 4WD - FULL-SIZE</b> <span style="float:right"><b>NOTE: ALL SHOCKS MUST BE ORDERED SEPARATELY</b></span>																											
<b>74-88 J10, J20 Pickup 4WD Kit With Rear Blocks</b>																											
3.5-4"	JP40K	E9, E12	JP40	2	JP40FS				JA350	7005			8005			9005			H7088	H7088	N8088	N8088	B8588	B8588	M9558	M9558	4
KIT NOTES: E9. Power Steering Models Only. E12. See Brake Lines Section.																											

LIFT	Quick Kit Reference	KIT NOTES	Component Box (Requires 1 of Each)	Front Springs		Rear Springs		Add-A-Leafs	Steering Correction (Order 1 Each)	Steering Stabilizers						HYDRO Shocks		NITRO Shocks		BLACK MAX		M95 Shocks		Labor Hours							
				Qty	Part #	Qty	Part #			White		Black		Silver		White		White		Black		Silver									
										OEM	Single	Dual	OEM	Single	Dual	OEM	Single	Dual	OEM	Single	Dual	Front	Rear	Front	Rear	Front	Rear	Front	Rear	Front	Rear
<b>74-88 J10, J20 Pickup 4WD System</b>																															
<b>Includes Front &amp; Rear Full Height Replacement Springs</b>																															
3.5-4"	JP40KS	E1, E9, E12	JP40S	2	JP40FS	2	JP40RS		JA350	7005			8005			9005						H7088	H7088	N8088	N8088	B8588	B8588	M9558	M9558		4

KIT NOTES: E1. 74-75 Models MUST have 131" Wheel Base & 7,200 lb. GVWR or More for Rear Springs to Fit.  
E9. Power Steering Models Only. E12. See Brake Lines Section.

**84-01 CHEROKEE XJ 4WD, 2WD** **NOTE: ALL SHOCKS MUST BE ORDERED SEPARATELY**

**POLYURETHANE VALUE KIT**

<b>84-01 Cherokee XJ 4WD, 2WD Kit</b>																															
<b>Polyurethane Spacers</b>																															
2"	XJ20		XJ20							7009			8009			9009						H7016	H7018	N8016	N8018	B8516	B8518	M9516	M9518		4

KIT NOTES: Includes Rear Lift Shackles.

**SPORT SERIES**

<b>84-01 Cherokee XJ 4WD, 2WD Kit</b>																																
<b>With Rear Add-A-Leafs</b>																																
3"	JC31BKH	E12	JC301BH		Included			Included		7009			8009			9009						Included	Included									

KIT NOTES: E12. See Brake Lines Section.

**84-01 Cherokee XJ 4WD, 2WD System**

<b>With Replacement Rear Springs (Dana 35 Rear Axle)</b>																																
3"	JC315BKSH	E12	JC315BSH		Included	2	JC25RSB			7009			8009			9009						Included	Included									
6"	JC605BKSH	E5, E11	JC60RRX + JC605BSH	1	JC60F	2	JC55RSB			7009			8009			9009						Included	Included									

KIT NOTES: E5. Slip Yoke Eliminator Kit # RR231 & Replacement CV Driveshaft is REQUIRED. Available Direct from Skyjacker®.  
E11. Transfer Case Lowering Kit Required - Part # TCL32. E12. See Brake Lines Section.

**84-01 Cherokee XJ 4WD, 2WD System**

<b>With Replacement Rear Springs (Chrysler 8.25" Rear Axle)</b>																																
3"	JC318BKSH	E12	JC318BSH		Included	2	JC25RSB			7009			8009			9009						Included	Included									
6"	JC608BKSH	E5, E11	JC60RRX + JC608BSH	1	JC60F	2	JC55RSB			7009			8009			9009						Included	Included									

KIT NOTES: E5. Slip Yoke Eliminator Kit # RR231 & Replacement CV Driveshaft is REQUIRED. Available Direct from Skyjacker®.  
E11. Transfer Case Lowering Kit Required - Part # TCL32. E12. See Brake Lines Section.

**STANDARD SERIES - SHORT ARM LOWER LINKS ONLY**

<b>84-01 Cherokee XJ 4WD, 2WD Kit</b>																															
<b>With Rear Add-A-Leafs</b>																															
3"	JC301K	E12	JC30	1	JC30F			R3136		7009			8009			9009						H7016	H7018	N8016	N8018	B8516	B8518	M9516	M9518		6
4.5"	JC451K	E12	JC45	1	JC45F			R3136		7009			8009			9009						H7025	H7028	N8025	N8028	B8525	B8528	M9525	M9528		6

KIT NOTES: E12. See Brake Lines Section.

**84-01 Cherokee XJ 4WD, 2WD System**

<b>With Replacement Rear Springs</b>																															
3"	JC301KS	E12	JC30S	1	JC30F	2	JC25RS			7009			8009			9009						H7016	H7018	N8016	N8018	B8516	B8518	M9516	M9518		6

KIT NOTES: E12. See Brake Lines Section.

**VALUE FLEX SERIES - SHORT ARMS WITH LOWER LINKS ONLY**

<b>84-01 Cherokee XJ 4WD, 2WD Kit</b>																															
<b>With Rear Add-A-Leafs</b>																															
3"	JC301K-SVX	E12	JC30-SVX	1	JC30F			R3136		7009			8009			9009						H7016	H7018	N8016	N8018	B8516	B8518	M9516	M9518		6
4.5"	JC451K-SVX	E11, E12	JC45-SVX	1	JC45F			R3136		7009			8009			9009						H7025	H7028	N8025	N8028	B8525	B8528	M9525	M9528		6

KIT NOTES: E11. Transfer Case Lowering Kit Required - Part # TCL32. E12. See Brake Lines Section.

**84-01 Cherokee XJ 4WD, 2WD System**

<b>With Replacement Rear Springs</b>																															
3"	JC301KS-SVX		JC30S-SVX	1	JC30F	2	JC25RS			7009			8009			9009						H7016	H7018	N8016	N8018	B8516	B8518	M9516	M9518		6

**ROCK READY® 2 SERIES**

<b>84-01 Cherokee XJ 4WD, 2WD System</b>																															
<b>With Replacement Rear Springs (Dana 35 Rear Axle)</b>																															
4.5"	JC455RR2KS		JC48RRX+JC405XS2	1	JC45F	2	JC25RS		Included													H7025	H7028	N8025	N8028	B8525	B8528	M9525	M9528		10
6"	JC605RR2KS	E5, E11	JC48RRX+JC605XS2	1	JC60F	2	JC55RS		Included													H7049	H7063	N8049	N8063	B8549	B8563	M9549	M9563		10

KIT NOTES: E5. Slip Yoke Eliminator Kit # RR231 (See Jeep Accessories) & Replacement CV Driveshaft is REQUIRED.  
E11. Transfer Case Lowering Kit Required - Part # TCL32.

**84-01 Cherokee XJ 4WD, 2WD System**

<b>With Replacement Rear Springs (Chrysler 8.25" Rear Axle)</b>																															
4.5"	JC458RR2KS		JC48RRX+JC408XS2	1	JC45F	2	JC25RS		Included													H7025	H7028	N8025	N8028	B8525	B8528	M9525	M9528		10
6"	JC608RR2KS	E5, E11	JC48RRX+JC608XS2	1	JC60F	2	JC55RS		Included													H7049	H7063	N8049	N8063	B8549	B8563	M9549	M9563		10

**84-01 Cherokee XJ 4WD, 2WD System**

<b>With Replacement Rear Springs (Dana 35 Rear Axle)</b>																															
8"	JC805RR2KS	E5, E11	JC48RRX+JC805XS2	1	JC80F	2	JC75RS		Included													H7049	H7063	N8049	N8063	B8549	B8563	M9549	M9563		10

**84-01 Cherokee XJ 4WD, 2WD System**

<b>With Replacement Rear Springs (Chrysler 8.25" Rear Axle)</b>																															
8"	JC808RR2KS	E5, E11	JC48RRX+JC808XS2	1	JC80F	2	JC75RS		Included													H7049	H7063	N8049	N8063	B8549	B8563	M9549	M9563		10

KIT NOTES: E5. Slip Yoke Eliminator Kit # RR231 (See Jeep Accessories) & Replacement CV Driveshaft is REQUIRED.  
E11. Transfer Case Lowering Kit Required - Part # TCL32.

**86-92 COMANCHE PICKUP MJ 4WD, 2WD** **NOTE: ALL SHOCKS MUST BE ORDERED SEPARATELY**

**POLYURETHANE VALUE KIT**

<b>86-92 Comanche Pickup MJ 4WD, 2WD Kit</b>																															
<b>Polyurethane Spacers</b>																															
2"	XJ20		XJ20							7009			8009			9009						H7016	H7023	N8016	N8023	B8516	B8523	M9516	M9523		4

KIT NOTES: Includes Rear Lift Shackles.

JEEP

JEEP

LIFT	Quick Kit	KIT NOTES	Component Box (Requires 1 of Each)	Front Springs		Rear Springs		Add-A-Leafs	Steering Correction (Order 1 Each)	Steering Stabilizers									HYDRO Shocks		NITRO Shocks		BLACK MAX		M95 Shocks		Labor Hours		
				Qty	Part #	Qty	Part #			White			Black			Silver			White		Black		Silver						
	OEM			Single	Dual	OEM	Single			Dual	OEM	Single	Dual	OEM	Single	Dual	Front	Rear	Front	Rear	Front	Rear	Front	Rear					
<b>STANDARD SERIES - SHORT ARM LOWER LINKS ONLY</b>																													
<b>86-92 Comanche Pickup MJ 4WD, 2WD Kit With Rear Add-A-Leafs</b>																													
3"	JC351K	E12	JC30	1	JC30F			R3136		7009			8009			9009			H7016	H7023	N8016	N8023	B8516	B8523	M9516	M9523	6		
KIT NOTES: E12. See Brake Lines Section.																													
<b>VALUE FLEX SERIES - SHORT ARMS WITH LOWER LINKS ONLY</b>																													
<b>86-92 Comanche Pickup MJ 4WD, 2WD Kit With Rear Add-A-Leafs (Includes NG Rebuildable Rod Ends)</b>																													
3"	JC351K-SVX	E12	JC30-SVX	1	JC30F			R3136		7009			8009			9009			H7016	H7023	N8016	N8023	B8516	B8523	M9516	M9523	6		
KIT NOTES: E12. See Brake Lines Section.																													
<b>06-10 COMMANDER XK 4WD, 2WD</b>																													
<b>POLYURETHANE VALUE KITS</b>																													
<b>06-10 Commander XK 4WD, 2WD Kit Polyurethane Spacers</b>																													
2"	XK20		XK20																									6	
<b>08-12 LIBERTY KK 4WD, 2WD</b>																													
<b>POLYURETHANE VALUE KITS</b>																													
<b>08-12 Liberty KK 4WD, 2WD Kit Polyurethane Spacers</b>																													
2.5"	KKN25		KKN25																										6
<b>08-12 Liberty KK 4WD, 2WD Kit With Rear Coil Springs</b>																													
2.5-3"	LIB258K		LIB250			1	LIB208R																						6
<b>02-07 LIBERTY KJ 4WD, 2WD</b>																													
<b>VALUE KITS</b>																													
<b>02-07 Liberty KJ 4WD, 2WD Kit Polyurethane Spacers</b>																													
2.5"	KJ25		KJ25																										6
KIT NOTES: Installs Inside Strut Assembly.																													
<b>PERFORMANCE COIL-OVER® SERIES</b>																													
<b>02-07 Liberty KJ 4WD, 2WD System With Rear Coil Springs</b>																													
2.5"	LIB250K	E21	LIB250			1	LIB25R																						8
KIT NOTES: E21. Skyjacker® Limiting Straps Recommended. Diesel Engines will Sit Lower in Front.																													
<b>05-10 GRAND CHEROKEE WK 4WD, 2WD</b>																													
<b>POLYURETHANE VALUE KIT</b>																													
<b>05-10 Grand Cherokee WK 4WD, 2WD Kit Polyurethane Spacers</b>																													
2"	WK20		WK20																										4
<b>99-04 GRAND CHEROKEE WJ 4WD, 2WD</b>																													
<b>POLYURETHANE VALUE KIT</b>																													
<b>99-04 Grand Cherokee WJ 4WD, 2WD Kit Polyurethane Spacers</b>																													
2"	WJ20		WJ20																										4
<b>93-98 GRAND CHEROKEE ZJ 4WD, 2WD</b>																													
<b>POLYURETHANE VALUE KIT</b>																													
<b>93-98 Grand Cherokee ZJ 4WD, 2WD Kit Polyurethane Spacers</b>																													
2"	ZJ20		ZJ20							7009			8009			9009			H7016	H7023	N8016	N8023	B8516	B8523	M9516	M9523	4		
<b>STANDARD SERIES - SHORT ARM LOWER LINKS ONLY</b>																													
<b>93-98 Grand Cherokee ZJ 4WD, 2WD System With Rear Coil Springs</b>																													
3"	GC301K		GC30	1	JC30F	1	GC20R			7009			8009			9009			H7016	H7023	N8016	N8023	B8516	B8523	M9516	M9523	4		

LIFT	Quick Kit	KIT NOTES	Component Box (Requires 1 of Each)	Front Springs		Rear Springs		Add-A-Leafs	Steering Correction (Order 1 Each)	Steering Stabilizers						HYDRO Shocks		NITRO Shocks		BLACK MAX		M95 Shocks		Labor Hours								
				Qty	Part #	Qty	Part #			White		Black		Silver		White		Black		Silver												
	OEM			Single	Dual	OEM	Single			Dual	OEM	Single	Dual	Front	Rear	Front	Rear	Front	Rear	Front	Rear	Front	Rear									
<b>94-97 MAZDA B3000,B4000 4WD</b>																																
<b>NOTE: ALL SHOCKS MUST BE ORDERED SEPARATELY</b>																																
<b>94-97 Mazda B3000,B4000 4WD Kit 6-Cylinder Engine with Add-A-Leafs</b>																																
1.5-2"	132XK	G1, G27		1	132X			R3135										H7052	H7060	N8052	N8060	B8552	B8560	M9552	M9560	4						
KIT NOTES: G1. Oversized Camber / Caster Shims are REQUIRED (See Mazda Accessories). G27. May Require # HS25 for Alignment & Leveling Aid.																																
<b>94-97 Mazda B3000,B4000 4WD Kit 4-Cylinder Engine with Add-A-Leafs</b>																																
1.5-2"	132K	G1, G27		1	132			R3135										H7052	H7060	N8052	N8060	B8552	B8560	M9552	M9560	4						
KIT NOTES: G1. Oversized Camber / Caster Shims are REQUIRED (See Mazda Accessories). G27. May Require # HS25 for Alignment & Leveling Aid.																																
<b>94-97 Mazda B3000,B4000 4WD System 6-Cylinder Engine with Replacement Rear Springs</b>																																
1.5-2"	132XKS	G1, G10	132XRS	1	132X	2	FR34S											H7052	H7060	N8052	N8060	B8552	B8560	M9552	M9560	4						
KIT NOTES: G1. Oversized Camber / Caster Shims are REQUIRED (See Mazda Accessories). G10. The Factory Block is Removed.																																
<b>94-97 Mazda B3000,B4000 4WD System 4-Cylinder Engine with Replacement Rear Springs</b>																																
1.5-2"	132KS	G1, G10	132RS	1	132	2	FR34S											H7052	H7060	N8052	N8060	B8552	B8560	M9552	M9560	4						
KIT NOTES: G1. Oversized Camber / Caster Shims are REQUIRED (See Mazda Accessories). G10. The Factory Block is Removed.																																
<b>94-97 Mazda B3000,B4000 4WD Kit Heavy-Duty Brackets with Blocks &amp; U-Bolts &amp;/or Add-A-Leafs</b>																																
4"	134RHK	G8, G18, G27	134RH	1	134				FA400									H7054	H7060	N8054	N8060	B8554	B8560	M9554	M9560	6						
6"	136RHK	G8, G18, G27	136RH	1	136				FA400									H7055	H7060	N8055	N8060	B8555	B8560	M9555	M9560	6						
8"	138RHK-A	G8, G18, G27	138C+138RH	1	138			R3135	Included									H7055	H7079	N8055	N8079	B8555	B8579	M9555	M9579	7						
KIT NOTES: G8. Power Steering Models Only. G27. May Require # HS25 for Alignment & Leveling Aid. May Require End Links. G18. See Brake Lines Section.																																
<b>94-97 Mazda B3000,B4000 4WD System Heavy-Duty Brackets with Replacement Rear Springs</b>																																
4"	134RHKS	G8, G10, G18, G27	134RHS	1	134	2	FR34S		FA400									H7054	H7060	N8054	N8060	B8554	B8560	M9554	M9560	6						
6"	136RHKS	G8, G18, G27	136RHS	1	136	2	FR34S		FA400									H7055	H7060	N8055	N8060	B8555	B8560	M9555	M9560	6						
8"	138RHKS-A	G8, G18, G27	138C+138RHS	1	138	2	FR36S		Included									H7055	H7079	N8055	N8079	B8555	B8579	M9555	M9579	7						
KIT NOTES: G8. Power Steering Models Only. G10. The Factory Block is Removed. G27. May Require # HS25 for Alignment & Leveling Aid. May Require End Links. G18. See Brake Lines Section.																																
<b>94-97 Mazda B3000,B4000 4WD Kit Class II Brackets &amp; Radius Arms with Blocks &amp; U-Bolts</b>																																
4"	234RHK-A	G8, G18, G27	234RH+RA135	1	134				Included									H7054	H7060	N8054	N8060	B8554	B8560	M9554	M9560	7						
6"	236RHK-A	G8, G18, G27	236RH+RA135	1	136				Included									H7055	H7060	N8055	N8060	B8555	B8560	M9555	M9560	7						
KIT NOTES: G8. Power Steering Models Only. G27. May Require # HS25 for Alignment & Leveling Aid. G18. See Brake Lines Section.																																
<b>94-97 Mazda B3000,B4000 4WD System Class II Brackets &amp; Radius Arms with Replacement Rear Springs</b>																																
4"	234RHKS-A	G8, G10, G18, G27	234RHS+RA135	1	134	2	FR34S		Included									H7054	H7060	N8054	N8060	B8554	B8560	M9554	M9560	7						
6"	236RHKS-A	G8, G18, G27	236RHS+RA135	1	136	2	FR34S		Included									H7055	H7060	N8055	N8060	B8555	B8560	M9555	M9560	7						
KIT NOTES: G8. Power Steering Models Only. G10. The Factory Block is Removed. G27. May Require # HS25 for Alignment & Leveling Aid. G18. See Brake Lines Section.																																
<b>94-97 MAZDA B SERIES B2300</b>																																
<b>NOTE: ALL SHOCKS MUST BE ORDERED SEPARATELY</b>																																
<b>94-97 Mazda B2300 2WD Kit 2.3, 2.9 &amp; 3.0 Liter Engines with Add-A-Leafs</b>																																
1.5-2"	132K	G1		1	132			R3135										7150	7250	8150	8250	9150	9250	H7052	H7058	N8052	N8058	B8552	B8558	M9552	M9558	4
KIT NOTES: G1. Oversized Camber / Caster Shims are REQUIRED (See Mazda Accessories).																																
<b>94-97 Mazda B2300 2WD Kit 4.0 Liter Engines with Add-A-Leafs</b>																																
1.5-2"	132XK	G1, G27		1	132X			R3135										7150	7250	8150	8250	9150	9250	H7052	H7058	N8052	N8058	B8552	B8558	M9552	M9558	4
KIT NOTES: G1. Oversized Camber / Caster Shims are REQUIRED (See Mazda Accessories). G27. May Require # HS25 for Alignment & Leveling Aid. 4.0 Model May Sit Lower in Front.																																
<b>94-97 Mazda B2300 2WD Kit 2.3 Liter Engine SuperCab with Add-A-Leafs</b>																																
1.5-2"	132K	G1		1	132			R3135										7150	7250	8150	8250	9150	9250	H7052	H7058	N8052	N8058	B8552	B8558	M9552	M9558	4
KIT NOTES: G1. Oversized Camber / Caster Shims are REQUIRED (See Mazda Accessories).																																
<b>94-97 Mazda B2300 2WD Kit 2.9 Liter Engine SuperCab with Add-A-Leafs</b>																																
1.5-2"	132XK	G1		1	132X			R3135										7150	7250	8150	8250	9150	9250	H7052	H7058	N8052	N8058	B8552	B8558	M9552	M9558	4
KIT NOTES: G1. Oversized Camber / Caster Shims are REQUIRED (See Mazda Accessories).																																
<b>94-97 Mazda B2300 2WD Kit Standard Brackets with Blocks &amp; U-Bolts</b>																																
4"	134R2K	G8, G18, G27	134R2	1	134				FA400									7150	7250	8150	8250	9150	9250	H7054	H7060	N8054	N8060	B8554	B8560	M9554	M9560	6
6"	136R2K	G8, G18, G27	136R2	1	136				FA400									7150	7250	8150	8250	9150	9250	H7055	H7060	N8055	N8060	B8555	B8560	M9555	M9560	6
KIT NOTES: G8. Power Steering Models Only. G18. See Brake Lines Section. G27. May Require # HS25 for Alignment & Leveling Aid. May Require End Links.																																
<b>94-97 Mazda B2300 2WD System Standard Brackets with Replacement Rear Springs</b>																																
4"	134R2KS	G8, G18, G27	134R2S	1	134	2	FR34S		FA400									7150	7250	8150	8250	9150	9250	H7054	H7060	N8054	N8060	B8554	B8560	M9554	M9560	6
6"	136R2KS	G8, G18, G27	136R2S	1	136	2	FR34S		FA400									7150	7250	8150	8250	9150	9250	H7055	H7060	N8055	N8060	B8555	B8560	M9555	M9560	6
KIT NOTES: G8. Power Steering Models Only. G18. See Brake Lines Section. G27. May Require # HS25 for Alignment & Leveling Aid. May Require End Links.																																







LIFT	Quick Kit Reference	KIT NOTES	Component Box (Requires 1 of Each)	Front Springs		Rear Springs		Add-A-Leafs	Steering Correction (Order 1 Each)	Steering Stabilizers						HYDRO Shocks		NITRO Shocks		BLACK MAX		M95 Shocks		Labor Hours					
				Qty	Part #	Qty	Part #			White		Black		Silver		White		White		Black		Silver							
										OEM	Single	Dual	OEM	Single	Dual	OEM	Single	Dual	Front	Rear	Front	Rear	Front		Rear	Front	Rear		
<b>LEDUC SERIES COIL-OVER KITS</b>																													
<b>07-17 Tundra Pickup 4WD Value Kit</b>		<b>Coil-Over Lift Kit with Blocks &amp; U-Bolts</b>																											
3"	TU730BM		Included		Included																					Included	4		
Kit includes front coil-over shocks, front coil springs, upper coil-over shock brackets, front sway bar relocation brackets, rear lift blocks, rear u-bolts, & rear M95 Monotube shocks (2).																													
<b>07-17 Tundra Pickup 4WD Value Kit</b>		<b>Adjustable Coil-Over Lift Kit</b>																											
2-3"	TU730K		TU730+TU710R																									4	
KIT NOTES: OEM Wheels & Tires can be Used.																													
<b>07-17 Tundra Pickup 4WD Value Kit</b>		<b>Coil-Over Lift Kit with Rear Blocks &amp; U-Bolts</b>																											
6-7"	TU762LSKM		TU762LS + TU746A + TU762BM																								Included	4	
KIT NOTES: 17" diameter or larger Wheel must be used. Does NOT fit TRD Pro Models. Kit includes front 2.5" remote reservoir coilover shocks w/ coil springs, front steering knuckles, front & rear cross members, front bump stop extension brackets, front differential skid plate, front differential relocation brackets, front driveshaft spacer, front sway bar end links, front sway bar lowering brackets, carrier bearing lowering bracket, front & rear brake line relocation brackets, rear blocks, rear U-bolts, & rear M95 monotube shocks.																													
<b>00-06 TUNDRA PICKUP 4WD</b>												<b>NOTE: ALL SHOCKS MUST BE ORDERED SEPARATELY</b>																	
<b>00-06 Tundra Pickup 4WD Value Kit</b>		<b>Metal Spacers (Front Leveling Kit)</b>																											
2"	TTU20MS		TTU20MS																										2
KIT NOTES: Installs Above Strut Assembly.																													
<b>POLY VALUE KITS</b>																													
<b>00-06 Tundra Pickup 4WD Value Kit</b>		<b>Polyurethane Value Kit with Rear Add-A-Leafs</b>																											
2.5"	TTU25		TTU25					RTU20																					4
KIT NOTES: Installs Above Strut Assembly.																													
<b>PERFORMANCE STRUT SERIES</b>																													
<b>00-06 Tundra Pickup 4WD Kit</b>		<b>Adjustable Front Struts</b>																											
1-3"	TT413ST		TT413ST																										4
<b>00-06 Tundra Pickup 4WD Kit</b>		<b>With Add-A-Leafs</b>																											
2.5-3"	TTU30STK		TT430ST					RTU20																					8
<b>LEDUC SERIES COIL-OVER KITS</b>																													
<b>00-06 Tundra Pickup 4WD Kit</b>		<b>With Add-A-Leafs</b>																											
2.5-3"	SKTUN30K		SKTUN30					RTU20																					4
<b>86-95 PICKUP STANDARD &amp; EXTENDED CAB 4WD</b>												<b>NOTE: ALL SHOCKS MUST BE ORDERED SEPARATELY</b>																	
<b>89-95 Pickup Standard Cab 4WD Kit</b>		<b>Class II with Blocks &amp; U-Bolts</b>																											
4"	T432K		T422 & T431R							7186		8186		9186		H7004	H7027	N8004	N8027	B8504	B8527	M9504	M9527					8	
<b>89-95 Pickup Extended Cab 4WD Kit</b>		<b>Class II with Blocks &amp; U-Bolts</b>																											
4"	T422K		T422 & T421R							7186		8186		9186		H7004	H7027	N8004	N8027	B8504	B8527	M9504	M9527					8	
<b>86-88 Pickup Standard &amp; Extended Cab 4WD Kit</b>		<b>Class II with Blocks &amp; U-Bolts</b>																											
4"	T422K		T422 & T421R							7186		8186		9186		H7004	H7027	N8004	N8027	B8504	B8527	M9504	M9527					8	
<b>89-95 Pickup Standard Cab 4WD System</b>		<b>Class II with Replacement Rear Springs</b>																											
4"	T432KS		T422 & T431RS			2	TR49S			7186		8186		9186		H7004	H7027	N8004	N8027	B8504	B8527	M9504	M9527					8	
<b>89-95 Pickup Extended Cab 4WD System</b>		<b>Class II with Replacement Rear Springs</b>																											
4"	T422KS		T422 & T421RS			2	TR49S			7186		8186		9186		H7004	H7027	N8004	N8027	B8504	B8527	M9504	M9527					8	
<b>86-88 Pickup Standard &amp; Extended Cab 4WD System</b>		<b>Class II with Replacement Rear Springs</b>																											
4"	T442KS		T422 & T421RS			2	TR40S			7186		8186		9186		H7004	H7027	N8004	N8027	B8504	B8527	M9504	M9527					8	
<b>84-85 PICKUP 4WD</b>												<b>NOTE: ALL SHOCKS MUST BE ORDERED SEPARATELY</b>																	
<b>84-85 Pickup 4WD Kit</b>		<b>Front Leafs with Blocks &amp; U-Bolts &amp;/or Add-A-Leafs</b>																											
3"	T303PK		T303P	2	T303S			R5005		7175	7276 <sup>(P)</sup>	8175	8276 <sup>(P)</sup>	9175	9276 <sup>(P)</sup>	H7055	H7027	N8055	N8027	B8555	B8527	M9555	M9527					4	
5"	T305PK		T305P	2	T305S				TDL5	7175	7276 <sup>(P)</sup>	8175	8276 <sup>(P)</sup>	9175	9276 <sup>(P)</sup>	H7055	H7036	N8055	N8036	B8555	B8536	M9555	M9536					6	
7"	T307PK	I1	T307P	2	T307S			R5005	TDL5	7175	7276 <sup>(P)</sup>	8175	8276 <sup>(P)</sup>	9175	9276 <sup>(P)</sup>	H7056	H7036	N8056	N8036	B8556	B8536	M9556	M9536					7	
NOTES: I1. 7" Lifts REQUIRE the Following: # TDL5 Adjustable Drag Link, # FBL30 & # RBL30 Longer Stainless Steel Brake Lines, Lengthening of Front Driveshaft & Modifying Factory Steering Arm so that Ball is Pointing Out the Top of Arm (Rather than Pointing Down).																													
<b>84-85 Pickup 4WD System</b>												<b>NOTE: ALL SHOCKS MUST BE ORDERED SEPARATELY</b>																	
<b>84-85 Pickup 4WD System</b>		<b>Front Leafs with Replacement Rear Springs</b>																											
3"	T303PKS		T303PS	2	T303S	2	TR20S			7175	7276 <sup>(P)</sup>	8175	8276 <sup>(P)</sup>	9175	9276 <sup>(P)</sup>	H7055	H7027	N8055	N8027	B8555	B8527	M9555	M9527					4	
5"	T305PKS		T305PS	2	T305S	2	TR40S		TDL5	7175	7276 <sup>(P)</sup>	8175	8276 <sup>(P)</sup>	9175	9276 <sup>(P)</sup>	H7055	H7036	N8055	N8036	B8555	B8536	M9555	M9536					6	
7"	T307PKS	I1	T307PS	2	T307S	2	TR60S		TDL5	7175	7276 <sup>(P)</sup>	8175	8276 <sup>(P)</sup>	9175	9276 <sup>(P)</sup>	H7056	H7036	N8056	N8036	B8556	B8536	M9556	M9536					7	
NOTES: I1. 7" Lifts REQUIRE the Following: # TDL5 Adjustable Drag Link, # FBL30 & # RBL30 Longer Stainless Steel Brake Lines, Lengthening of Front Driveshaft & Modifying Factory Steering Arm so that Ball is Pointing Out the Top of Arm (Rather than Pointing Down).																													





LIFT	Quick Kit	KIT NOTES	Component Box	Front Springs		Rear Springs		Add-A-Leafs	Steering Correction	Steering Stabilizers						HYDRO Shocks		NITRO Shocks		BLACK MAX		M95 Shocks		Labor Hours				
				Qty	Part #	Qty	Part #			White		Black		Silver		White		Black		Silver								
				(Requires 1 of Each)	(Order 1 Each)	OEM	Single			Dual	OEM	Single	Dual	OEM	Single	Dual	Front	Rear	Front	Rear	Front	Rear	Front		Rear			
<b>84-85 4Runner 4WD System</b>																												
<b>Front Leafs with Replacement Rear Springs</b>																												
3"	T303RKS		T303PS	2	T303S	2	TR40S																					
5"	T305RKS		T305PS	2	T305S	2	TR60S		TDL5																			
7"	T307RKS	I1, I4	T307RS	2	T307S	2	TR60S		TDL5																			
KIT NOTES: I1, 7" Lifts REQUIRE the Following: # TDL5 Adjustable Drag Link, # FBL30 & # RBL30 Longer Stainless Steel Brake Lines, Lengthening of Front Driveshaft & Modifying Factory Steering Arm so that Ball is Pointing Out the Top of Arm (Rather than Pointing Down). I4. This Lift also Includes 2" Blocks.										(P) Parallel Mount																		
<b>01-07 SEQUOIA 4WD / 2WD</b>																												
<b>NOTE: ALL SHOCKS MUST BE ORDERED SEPARATELY</b>																												
<b>01-07 Sequoia 2WD / 4WD Value Kit</b>																												
<b>Metal Spacers (Front Leveling Kit)</b>																												
2"	TU20MS		TU20MS																									
<b>01-07 SEQUOIA 2WD / 4WD</b>																												
<b>NOTE: ALL SHOCKS MUST BE ORDERED SEPARATELY</b>																												
<b>01-07 Sequoia 2WD / 4WD Value Kit</b>																												
<b>Polyurethane Spacer Leveling Kit</b>																												
2.5"	TSQ25		TSQ25																									
<b>07-14 FJ CRUISER 4WD</b>																												
<b>NOTE: ALL SHOCKS MUST BE ORDERED SEPARATELY</b>																												
<b>VALUE KIT</b>																												
<b>07-14 FJ Cruiser 4WD KIT</b>																												
<b>Metal Spacers (Front Leveling Kit)</b>																												
2"	TT20MS		TT20MS																									
KIT NOTES: Installs above Strut assembly.																												
<b>07-14 FJ Cruiser 4WD KIT</b>																												
<b>Spacer Kit (2" Metal Front &amp; 1.5" Polyurethane Rear)</b>																												
2"	FJ20MS		FJ20MS																									
<b>PERFORMANCE STRUT SERIES</b>																												
<b>07-14 FJ Cruiser 4WD KIT</b>																												
<b>Adjustable Front Struts</b>																												
1-3"	FJ713ST		Included																									
<b>07-14 FJ Cruiser 4WD KIT</b>																												
<b>Front Struts with Rear Coil Springs and Shocks</b>																												
3"	FJ730STBH		Included																									
Kit includes front struts, rear coil springs, rear sway bar end links, & rear Hydro 7000 shocks (2).																												
3"	FJ730STBN		Included																									
Kit includes front struts, rear coil springs, rear sway bar end links, & rear Nitro 8000 shocks (2).																												
3"	FJ730STBB		Included																									
Kit includes front struts, rear coil springs, rear sway bar end links, & rear Black MAX shocks (2).																												
3"	FJ730STBM		Included																									
Kit includes front struts, rear coil springs, rear sway bar end links, & rear M95 Monotube shocks (2).																												
<b>07-14 FJ Cruiser 4WD KIT</b>																												
<b>With Rear Coil Springs</b>																												
3"	FJ730STK		FJ730ST				Included																					
KIT NOTES: FJ730STK Includes Rear Coil Springs & Sway Bar End Links.																												
<b>LEDUC SERIES Coil-Over Kits</b>																												
<b>07-14 FJ Cruiser 4WD KIT</b>																												
<b>With Front &amp; Rear Coil Springs</b>																												
3"	FJ730BM		Included		Included		Included																					
Kit includes front coil-over shocks, front coil springs, upper coil-over shock brackets, front sway bar relocation brackets, rear coil springs, rear sway bar end links, & rear M95 Monotube shocks (2).																												
<b>07-14 FJ Cruiser 4WD KIT</b>																												
<b>With Rear Coil Springs</b>																												
3"	FJ730K		FJ730		Included		Included																					
KIT NOTES: FJ730K Includes Rear Coil Springs & Sway Bar End Links.																												
<b>64-80 FJ40 LANDCRUISER 4WD</b>																												
<b>NOTE: ALL SHOCKS MUST BE ORDERED SEPARATELY</b>																												
<b>64-80 FJ40 LandCruiser 4WD System</b>																												
<b>Front Leafs with Replacement Springs</b>																												
2.5"	L20KS		L24S	2	L20FS	2	L20RS																					
4"	L40KS		L24S	2	L40FS	2	L40RS																					
<b>64-80 FJ40 LandCruiser 4WD System</b>																												
<b>Shackle Reversal Front Leafs with Replacement Springs</b>																												
2.5"-4"	L24KS	I2	L24S	2	L20FS	2	L40RS																					
NOTES: I2. This System is for Applications that HAVE Installed a Front Shackle Correction Kit which has Increased the Front 1.5". This System Adds 2.5" Front & 4" Rear to be Level.																												

LIFT	Quick Kit	KIT NOTES	Component Box
	Reference		(Requires 1 of Each)
<b>13-18 POLARIS RANGER 900 XP / CREW 4WD</b>			
13-18 Polaris Ranger 900 XP / Crew 4WD			<b>Forward A-Arm Kit</b>
2"	FAA303		FAA303
13 Polaris Ranger 900 XP / Crew 4WD			<b>Nerf Bars</b>
	NBP103		NBP103
<b>05-12 POLARIS RANGER XP / CREW 4WD</b>			
05-12 Polaris Ranger XP / Crew 4WD			<b>Forward A-Arm Kit</b>
1"	FAA281		FAA281
KIT NOTES: This Lift is Designed to Fit Midsize Polaris Ranger Applications Equipped with McPerson Struts Thru 2012. See Listed Applications Here: 05-08 Polaris Ranger 500 XP, 06-09 Polaris Ranger 700 XP / Crew & 10-12 Polaris Ranger EV, 400, 500 XP / Crew.			
<b>10-12 POLARIS RANGER CREW 4WD</b>			
10-12 Polaris Ranger Crew 4WD			<b>Forward A-Arm Kit</b>
2"	FAA301		FAA301
KIT NOTES: Easy Bolt on Installation. Includes Upper & Lower A-Arms, Bushings, Front Bumper Relocation Brackets, & Upper Shock Relocation Brackets. Moves Tire Forward to Clear 30" Tires & Retains OEM Ride. Maintains OEM Suspension Travel, Ball Joints, & Suspension Geometry.			
10-12 Polaris Ranger Crew 4WD			<b>Rear Winch Mount</b>
	RWM101		RWM101
KIT NOTES: Kit Mounts to Rear Frame & Retains Use of Receiver Hitch. 3/16" P&O Steel with Grade 8 Mounting Hardware. Install Up to 4,000 lb. Rear Winch.			
10-12 Polaris Ranger Crew 4WD			<b>Nerf Bars</b>
	NBPC101		NBPC101
10-12 Polaris Ranger XP 4WD			<b>Nerf Bars</b>
	NBP100		NBP100
<b>10-15 POLARIS RANGER CREW 4WD</b>			
10-15 Polaris 800,900, & 1000			<b>Coil Springs</b>
1-2"	P8912		P8912
KIT NOTES: Will Not Fit Midsize Models with Struts.			



FAA303



P8912



FAA281

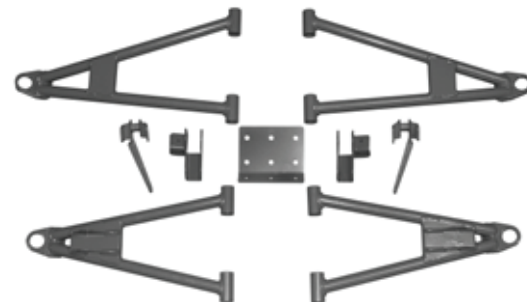

FAA301



RWM101

Lift Height	HYDRO		Fact. Front Dual	NITRO		Fact. Front Dual	BLACK MAX		Fact. Front Dual	MONOTUBE					
	Front	Rear		Front	Rear		Front	Rear		Front	Rear				
<b>CADILLAC</b>															
<b>02-06 Escalade / ESV / EXT 4WD / 2WD</b>															
0"	0-2"	H7009	H7027	----	----	N8009	N8027	----	----	B8509	B8527	----	----	M9509	M9527
2-3"	3-4"	H7003	H7017	----	----	N8003	N8017	----	----	B8503	B8517	----	----	M9503	M9517
5-6"	5-6"	H7096	H7070	----	----	N8096	N8070	----	----	B8596	B8570	----	----	M9596	M9570
<b>99-01 Escalade 4WD</b>															
0"	0"	H7081 <sup>(A10)</sup>	H7084 <sup>(A10)</sup>	----	----	N8081 <sup>(A10)</sup>	N8084 <sup>(A10)</sup>	----	----	B8581 <sup>(A10)</sup>	B8584 <sup>(A10)</sup>	----	----	M9581 <sup>(A10)</sup>	M9584 <sup>(A10)</sup>
SHOCK NOTES: A10. Shocks Not Intended for Auto Ride Models.															
<b>CHEVROLET \ GMC</b>															
<b>07-13 Avalanche 1500 4WD / 2WD (Strut Front End)</b>															
----	0-2"	----	H7027	----	----	----	N8027	----	----	----	B8527	----	----	----	M9527
----	3-4"	----	H7030	----	----	----	N8030	----	----	----	B8530	----	----	----	M9530
----	5-6"	----	H7070	----	----	----	N8070	----	----	----	B8570	----	----	----	M9570
<b>02-06 Avalanche 1500 4WD / 2WD</b>															
0-1"	0-2"	H7009 <sup>(A10)</sup>	H7027 <sup>(A10)</sup>	----	----	N8009 <sup>(A10)</sup>	N8027 <sup>(A10)</sup>	----	----	B8509 <sup>(A10)</sup>	B8527 <sup>(A10)</sup>	----	----	M9509 <sup>(A10)</sup>	M9527 <sup>(A10)</sup>
3-4"	3-4"	H7003 <sup>(A10)</sup>	H7017 <sup>(A10)</sup>	----	----	N8003 <sup>(A10)</sup>	N8017 <sup>(A10)</sup>	----	----	B8503 <sup>(A10)</sup>	B8517 <sup>(A10)</sup>	----	----	M9503 <sup>(A10)</sup>	M9517 <sup>(A10)</sup>
5-6"	5-6"	H7096 <sup>(A10)</sup>	H7036 <sup>(A10)</sup>	----	----	N8096 <sup>(A10)</sup>	N8036 <sup>(A10)</sup>	----	----	B8596 <sup>(A10)</sup>	B8536 <sup>(A10)</sup>	----	----	M9596 <sup>(A10)</sup>	M9536 <sup>(A10)</sup>
SHOCK NOTES: A10. Shocks Not Intended for Auto Ride Models.															
<b>02-06 Avalanche 2500 4WD</b>															
0-1"	0-2"	H7074 <sup>(A10)</sup>	H7017 <sup>(A10)</sup>	----	----	N8074 <sup>(A10)</sup>	N8017 <sup>(A10)</sup>	----	----	B8574 <sup>(A10)</sup>	B8517 <sup>(A10)</sup>	----	----	M9574 <sup>(A10)</sup>	M9517 <sup>(A10)</sup>
5-6"	3-6"	H7074 <sup>(A10)</sup>	H7036 <sup>(A10)</sup>	----	----	N8074 <sup>(A10)</sup>	N8036 <sup>(A10)</sup>	----	----	B8574 <sup>(A10)</sup>	B8536 <sup>(A10)</sup>	----	----	M9574 <sup>(A10)</sup>	M9536 <sup>(A10)</sup>
SHOCK NOTES: A10. Shocks Not Intended for Auto Ride Models.															
<b>04-12 Colorado / Canyon 4WD / 2WD</b>															
3-5"	3-4"	H7040 <sup>(A10)</sup>	H7084 <sup>(A10)</sup>	----	----	N8040 <sup>(A10)</sup>	N8084 <sup>(A10)</sup>	----	----	B8540 <sup>(A10)</sup>	B8584 <sup>(A10)</sup>	----	----	----	M9584 <sup>(A10)</sup>
<b>07-18 1500 Pickup 4WD / 2WD (Strut Front End)</b>															
----	0"	----	H7027	----	----	----	N8027	----	----	----	B8527	----	----	----	M9527
----	1.5-3"	----	H7017	----	----	----	N8017	----	----	----	B8517	----	----	----	M9517
----	4-6"	----	H7036	----	----	----	N8036	----	----	----	B8536	----	----	----	M9536
<b>88-98 1500 Pickup 2WD</b>															
1-2.5"	0-2"	H7006	H7072	----	----	----	N8072	----	----	B8506	B8572	----	----	M9506	M9572
<b>88-98 1500, 2500 &amp; 3500 Pickup 4WD with IFS</b>															
0-3"	0-2"	H7081	H7083	----	----	N8081	N8083	----	----	B8581	B8583	----	----	M9581	M9583
4-6"	3-5.5"	H7085	H7086	----	----	N8085	N8086	----	----	B8585	B8586	----	----	M9585	M9586
<b>99-06 1500 Pickup 2WD</b>															
0-2"	0-2"	H7006	H7030	----	----	----	N8030	----	----	B8506	B8530	----	----	M9506	M9530
<b>99-06 K1500 Pickup 4WD</b>															
0-1"	0-2"	H7009 <sup>(A10)</sup>	H7017 <sup>(A10)</sup>	----	----	N8009 <sup>(A10)</sup>	N8017 <sup>(A10)</sup>	----	----	B8509 <sup>(A10)</sup>	B8517 <sup>(A10)</sup>	----	----	M9509 <sup>(A10)</sup>	M9517 <sup>(A10)</sup>
2-3"	0-2"	H7003 <sup>(A10)</sup>	H7017 <sup>(A10)</sup>	----	----	N8003 <sup>(A10)</sup>	N8017 <sup>(A10)</sup>	----	----	B8503 <sup>(A10)</sup>	B8517 <sup>(A10)</sup>	----	----	M9503 <sup>(A10)</sup>	M9517 <sup>(A10)</sup>
5-6"	3-6"	H7096 <sup>(A10)</sup>	H7036 <sup>(A10)</sup>	----	----	N8096 <sup>(A10)</sup>	N8036 <sup>(A10)</sup>	----	----	B8596 <sup>(A10)</sup>	B8536 <sup>(A10)</sup>	----	----	M9596 <sup>(A10)</sup>	M9536 <sup>(A10)</sup>
SHOCK NOTES: A10. Shocks Not Intended for Auto Ride Models.															
<b>01-08 1500HD Pickup 4WD</b>															
0"	0-3"	H7019 <sup>(A10)</sup>	H7017 <sup>(A10)</sup>	----	----	N8019 <sup>(A10)</sup>	N8017 <sup>(A10)</sup>	----	----	B8519 <sup>(A10)</sup>	B8517 <sup>(A10)</sup>	----	----	M9519 <sup>(A10)</sup>	M9517 <sup>(A10)</sup>
2"	2"	H7004 <sup>(A10)</sup>	H7017 <sup>(A10)</sup>	----	----	N8004 <sup>(A10)</sup>	N8017 <sup>(A10)</sup>	----	----	B8504 <sup>(A10)</sup>	B8517 <sup>(A10)</sup>	----	----	M9504 <sup>(A10)</sup>	M9517 <sup>(A10)</sup>
5-6"	4-6"	H7074 <sup>(A10)</sup>	H7036 <sup>(A10)</sup>	----	----	N8074 <sup>(A10)</sup>	N8036 <sup>(A10)</sup>	----	----	B8574 <sup>(A10)</sup>	B8536 <sup>(A10)</sup>	----	----	M9574 <sup>(A10)</sup>	M9536 <sup>(A10)</sup>
SHOCK NOTES: A10. Shocks Not Intended for Auto Ride Models.															
<b>11-18 2500HD / 3500HD Pickup 4WD</b>															
2"	0"	----	H7027	----	----	----	N8027	----	----	----	B8527	----	----	----	M9527
<b>01-10 2500HD / 3500HD Pickup 4WD</b>															
0"	0-2"	H7019 <sup>(A10)</sup>	H7017 <sup>(A10)</sup>	----	----	N8019 <sup>(A10)</sup>	N8017 <sup>(A10)</sup>	----	----	B8519 <sup>(A10)</sup>	B8517 <sup>(A10)</sup>	----	----	M9519 <sup>(A10)</sup>	M9517 <sup>(A10)</sup>
2"	2"	H7004 <sup>(A10)</sup>	H7017 <sup>(A10)</sup>	----	----	N8004 <sup>(A10)</sup>	N8017 <sup>(A10)</sup>	----	----	B8504 <sup>(A10)</sup>	B8517 <sup>(A10)</sup>	----	----	M9504 <sup>(A10)</sup>	M9517 <sup>(A10)</sup>
3-6"	3-6"	H7074 <sup>(A10)</sup>	H7036 <sup>(A10)</sup>	----	----	N8074 <sup>(A10)</sup>	N8036 <sup>(A10)</sup>	----	----	B8574 <sup>(A10)</sup>	B8536 <sup>(A10)</sup>	----	----	M9574 <sup>(A10)</sup>	M9536 <sup>(A10)</sup>
SHOCK NOTES: A10. Shocks Not Intended for Auto Ride Models.															
<b>02-10 Hummer H2 4WD</b>															
0"	0-2"	H7019	H7017	----	----	N8019	N8017	----	----	B8519	B8517	----	----	M9519	M9517
2-3"	0-2"	H7004	H7017	----	----	N8004	N8017	----	----	B8504	B8517	----	----	M9504	M9517
5-6"	3-6"	H7074	H7036	----	----	N8074	N8036	----	----	B8574	B8536	----	----	M9574	M9536
<b>06-10 Hummer H3 / H3T 4WD</b>															
0"	0-1.5"	H7009	H7029	----	----	N8009	N8029	----	----	B8509	B8529	----	----	M9509	M9529
2-3"	0-1.5"	H7003	H7029	----	----	N8003	N8029	----	----	B8503	B8529	----	----	M9503	M9529
<b>07-17 Suburban / Yukon XL 1500 4WD (Strut Front End)</b>															
----	0-1"	----	H7027	----	----	----	N8027	----	----	----	B8527	----	----	----	M9527
----	2-3"	----	H7030	----	----	----	N8030	----	----	----	B8530	----	----	----	M9530
----	4-6"	----	H7070	----	----	----	N8070	----	----	----	B8570	----	----	----	M9570
<b>00-06 Suburban 1500 4WD</b>															
0-1"	0-2"	H7009 <sup>(A10)</sup>	H7027 <sup>(A10)</sup>	----	----	N8009 <sup>(A10)</sup>	N8027 <sup>(A10)</sup>	----	----	B8509 <sup>(A10)</sup>	B8527 <sup>(A10)</sup>	----	----	M9509 <sup>(A10)</sup>	M9527 <sup>(A10)</sup>
3-4"	3-4"	H7003 <sup>(A10)</sup>	H7017 <sup>(A10)</sup>	----	----	N8003 <sup>(A10)</sup>	N8017 <sup>(A10)</sup>	----	----	B8503 <sup>(A10)</sup>	B8517 <sup>(A10)</sup>	----	----	M9503 <sup>(A10)</sup>	M9517 <sup>(A10)</sup>
5-6"	5-6"	H7096 <sup>(A10)</sup>	H7036 <sup>(A10)</sup>	----	----	N8096 <sup>(A10)</sup>	N8036 <sup>(A10)</sup>	----	----	B8596 <sup>(A10)</sup>	B8536 <sup>(A10)</sup>	----	----	M9596 <sup>(A10)</sup>	M9536 <sup>(A10)</sup>
SHOCK NOTES: A10. Shocks Not Intended for Auto Ride Models.															

# SHOCK APPLICATION GUIDE

Lift Height		HYDRO		Fact. Front	NITRO		Fact. Front	BLACK MAX		Fact. Front	MONOTUBE	
Front	Rear	Front	Rear	Dual	Front	Rear	Dual	Front	Rear	Dual	Front	Rear
<b>07-17 Tahoe / Yukon (Strut Front End)</b>												
----	0-1"	----	H7027	----	----	N8027	----	----	B8527	----	----	M9527
----	2-3"	----	H7030	----	----	N8030	----	----	B8530	----	----	M9530
----	4-6"	----	H7070	----	----	N8070	----	----	B8570	----	----	M9570
<b>00-06 Tahoe / Yukon 1500 4WD</b>												
0-1"	0-2"	H7009 <sup>(A10)</sup>	H7027 <sup>(A10)</sup>	----	N8009 <sup>(A10)</sup>	N8027 <sup>(A10)</sup>	----	B8509 <sup>(A10)</sup>	B8527 <sup>(A10)</sup>	----	M9509 <sup>(A10)</sup>	M9527 <sup>(A10)</sup>
2-4"	3-4"	H7003 <sup>(A10)</sup>	H7017 <sup>(A10)</sup>	----	N8003 <sup>(A10)</sup>	N8017 <sup>(A10)</sup>	----	B8503 <sup>(A10)</sup>	B8517 <sup>(A10)</sup>	----	M9503 <sup>(A10)</sup>	M9517 <sup>(A10)</sup>
5-6"	5-6"	H7096 <sup>(A10)</sup>	H7036 <sup>(A10)</sup>	----	N8096 <sup>(A10)</sup>	N8036 <sup>(A10)</sup>	----	B8596 <sup>(A10)</sup>	B8536 <sup>(A10)</sup>	----	M9596 <sup>(A10)</sup>	M9536 <sup>(A10)</sup>
SHOCK NOTES: A10. Shocks Not Intended for Auto Ride Models.												
<b>07-17 Yukon XL 1500 4WD (Strut Front End)</b>												
----	0-1"	----	H7027	----	----	N8027	----	----	B8527	----	----	M9527
----	2-3"	----	H7030	----	----	N8030	----	----	B8530	----	----	M9530
----	4-6"	----	H7070	----	----	N8070	----	----	B8570	----	----	M9570
<b>00-06 Yukon XL 1500 4WD</b>												
0-1"	0-2"	H7009 <sup>(A10)</sup>	H7027 <sup>(A10)</sup>	----	N8009 <sup>(A10)</sup>	N8027 <sup>(A10)</sup>	----	B8509 <sup>(A10)</sup>	B8527 <sup>(A10)</sup>	----	M9509 <sup>(A10)</sup>	M9527 <sup>(A10)</sup>
3-4"	3-4"	H7003 <sup>(A10)</sup>	H7017 <sup>(A10)</sup>	----	N8003 <sup>(A10)</sup>	N8017 <sup>(A10)</sup>	----	B8503 <sup>(A10)</sup>	B8517 <sup>(A10)</sup>	----	M9503 <sup>(A10)</sup>	M9517 <sup>(A10)</sup>
5-6"	5-6"	H7096 <sup>(A10)</sup>	H7036 <sup>(A10)</sup>	----	N8096 <sup>(A10)</sup>	N8036 <sup>(A10)</sup>	----	B8596 <sup>(A10)</sup>	B8536 <sup>(A10)</sup>	----	M9596 <sup>(A10)</sup>	M9536 <sup>(A10)</sup>
SHOCK NOTES: A10. Shocks Not Intended for Auto Ride Models.												
<b>00-06 Tahoe / Yukon 2500 4WD</b>												
0"	0-2"	H7019 <sup>(A10)</sup>	H7027 <sup>(A10)</sup>	----	N8019 <sup>(A10)</sup>	N8027 <sup>(A10)</sup>	----	B8519 <sup>(A10)</sup>	B8527 <sup>(A10)</sup>	----	M9519 <sup>(A10)</sup>	M9527 <sup>(A10)</sup>
5-6"	3-6"	H7074 <sup>(A10)</sup>	H7036 <sup>(A10)</sup>	----	N8074 <sup>(A10)</sup>	N8036 <sup>(A10)</sup>	----	B8574 <sup>(A10)</sup>	B8536 <sup>(A10)</sup>	----	M9574 <sup>(A10)</sup>	M9536 <sup>(A10)</sup>
SHOCK NOTES: A10. Shocks Not Intended for Auto Ride Models.												
<b>73-87 1500 &amp; 2500 Pickup 4WD</b>												
0-1.5"	0-1.5"	H7021	H7043	H7023	N8021	N8043	N8023	B8521	B8543	B8523	M9521	M9543
2-5"	2-4"	H7051	H7053	H7058	N8051	N8053	N8058	B8551	B8553	B8558	M9551	M9553
<b>73-87 1500 &amp; 2500 Pickup 4WD</b>												
6-8"	4.5-8"	H7071	H7073	H7060	N8071	N8073	N8060	B8571	B8573	B8560	M9571	M9573
9-12"	9-12"	H7032	H7078	H7079	N8032	N8078	N8079	B8532	B8578	B8579	M9532	M9578
<b>67-72 1500 &amp; 2500 Pickup, Blazer, Jimmy 4WD</b>												
0-1.5"	0-1.5"	H7021	H7023	----	N8021	N8023	----	B8521	B8523	----	M9521	M9523
2-5"	2-4"	H7051	H7041	----	N8051	N8041	----	B8551	B8541	----	M9551	M9541
6-8"	4.5-8"	H7071	H7060	----	N8071	N8060	----	B8571	B8560	----	M9571	M9560
<b>77-87 2500 Pickup 4WD</b>												
0-1.5"	0-1.5"	H7021	H7053	H7023	N8021	N8053	N8023	B8521	B8553	B8523	M9521	M9553
2-5"	2-4"	H7051	H7073	H7058	N8051	N8073	N8058	B8551	B8573	B8558	M9551	M9573
6-8"	4.5-10"	H7071	H7078	H7060	N8071	N8078	N8060	B8571	B8578	B8560	M9571	M9578
9-12"	4.5-10"	H7032	H7078	H7079	N8032	N8078	N8079	B8532	B8578	B8579	M9532	M9578
<b>73-87 1500, 2500 &amp; 3500 C10, C20 &amp; C30 Pickup 2WD</b>												
0-1"	0-2"	H7080	H7043	----	----	N8043	----	----	B8543	----	----	M9543
1.5-3"	3-4"	H7011	H7083	----	N8011	N8083	----	B8511	B8583	----	M9511	M9583
<b>63-72 1500, 2500 &amp; 3500 C10, C20 &amp; C30 Pickup 2WD</b>												
0-1"	0"	H7080	H7012	----	----	N8012	----	----	B8512	----	----	M9512
1.5-3"	1-3"	H7011	H7023	----	N8011	N8023	----	B8511	B8523	----	M9511	M9523
<b>00-06 Suburban 1500 4WD</b>												
0-1"	0-2"	H7009 <sup>(A10)</sup>	H7027 <sup>(A10)</sup>	----	N8009 <sup>(A10)</sup>	N8027 <sup>(A10)</sup>	----	B8509 <sup>(A10)</sup>	B8527 <sup>(A10)</sup>	----	M9509 <sup>(A10)</sup>	M9527 <sup>(A10)</sup>
3-4"	3-4"	H7003 <sup>(A10)</sup>	H7017 <sup>(A10)</sup>	----	N8003 <sup>(A10)</sup>	N8017 <sup>(A10)</sup>	----	B8503 <sup>(A10)</sup>	B8517 <sup>(A10)</sup>	----	M9503 <sup>(A10)</sup>	M9517 <sup>(A10)</sup>
5-6"	5-6"	H7096 <sup>(A10)</sup>	H7036 <sup>(A10)</sup>	----	N8096 <sup>(A10)</sup>	N8036 <sup>(A10)</sup>	----	B8596 <sup>(A10)</sup>	B8536 <sup>(A10)</sup>	----	M9596 <sup>(A10)</sup>	M9536 <sup>(A10)</sup>
SHOCK NOTES: A10. Shocks Not Intended for Auto Ride Models.												
<b>00-06 Suburban 2500 4WD</b>												
0"	0-2"	H7019	H7017	----	N8019	N8017	----	B8519	B8517	----	M9519	M9517
5-6"	3-6"	H7074	H7036	----	N8074	N8036	----	B8574	B8536	----	M9574	M9536
<b>95-00 Tahoe, Yukon 4WD</b>												
0-3"	0-2"	H7081	H7084	----	N8081	N8084	----	B8581	B8584	----	M9581	M9584
4-6"	3-5.5"	H7085	H7083	----	N8085	N8083	----	B8585	B8583	----	M9585	M9583
<b>92-99 Suburban 4WD</b>												
0-3"	0-2.5"	H7081	H7084	----	N8081	N8084	----	B8581	B8584	----	M9581	M9584
4-6"	3-5.5"	H7085	H7083	----	N8085	N8083	----	B8585	B8583	----	M9585	M9583
<b>73-91 Blazer, Jimmy, Suburban 4WD</b>												
0-1.5"	0-1.5"	H7021	H7043	H7023	N8021	N8043	N8023	B8521	B8543	B8523	M9521	M9543
2-5"	2-4"	H7051	H7053	H7058	N8051	N8053	N8058	B8551	B8553	B8558	M9551	M9553
6-8"	4.5-8"	H7071	H7073	H7060	N8071	N8073	N8060	B8571	B8573	B8560	M9571	M9573
9-12"	9-12"	H7032	H7078	H7079	N8032	N8078	N8079	B8532	B8578	B8579	M9532	M9578
<b>73-84 Blazer, Jimmy 2WD - Full-Size</b>												
0-1"	0-2"	H7080	H7043	----	----	N8043	----	----	B8543	----	----	M9543
1.5-3"	3-4"	H7011	H7083	----	N8011	N8083	----	B8511	B8583	----	M9511	M9583

# SHOCK APPLICATION GUIDE

Lift Height		HYDRO		Fact. Front	NITRO		Fact. Front	BLACK MAX		Fact. Front	MONOTUBE	
Front	Rear	Front	Rear	Dual	Front	Rear	Dual	Front	Rear	Dual	Front	Rear
<b>67-72 Blazer, Jimmy 2WD</b>												
0-1"	0"	H7080	H7012	----	----	N8012	----	----	B8512	----	----	M9512
1.5-3"	1-3"	H7011	H7023	----	N8011	N8023	----	B8511	B8523	----	M9511	M9523
<b>69-91 Suburban 2WD</b>												
0-1"	0-2"	H7080	H7043	----	----	N8043	----	----	B8543	----	----	M9543
1.5-3"	3-4"	H7011	H7083	----	N8011	N8083	----	B8511	B8583	----	M9511	M9583
<b>94-98 S10 / S15 Series Pickup 4WD with ZR2 Package</b>												
0-2"	0-2"	H7082	H7072	----	N8082	N8072	----	B8582	B8572	----	M9582	M9572
0-3"	0-3"	H7082	H7083	----	N8082	N8083	----	B8582	B8583	----	M9582	M9583
<b>DODGE</b>												
<b>09-18 Ram 1500 Pickup 4WD</b>												
----	0-2"	----	H7030	----	----	N8030	----	----	B8530	----	----	M9530
----	3-4"	----	H7017	----	----	N8017	----	----	B8517	----	----	M9517
----	5-6"	----	H7070	----	----	N8070	----	----	B8570	----	----	M9570
<b>09-18 Ram 1500 Pickup 2WD</b>												
1-2.5"	0-2"	H7006	H7030	----	----	N8030	----	B8506	B8530	----	M9506	M9530
----	3-4"	----	H7017	----	----	N8017	----	----	B8517	----	----	M9517
----	5-6"	----	H7070	----	----	N8070	----	----	B8570	----	----	M9570
<b>06-08 Ram 1500 Pickup 4WD</b>												
----	0"	----	H7017	----	----	N8017	----	----	B8517	----	----	M9517
----	1-2"	----	H7070	----	----	N8070	----	----	B8570	----	----	M9570
----	3-5"	----	H7036	----	----	N8036	----	----	B8536	----	----	M9536
<b>02-08 Ram 1500 Pickup 2WD</b>												
1-2.5"	0-1"	H7020	H7017	----	----	N8017	----	B8520	B8517	----	M9520	M9517
<b>02-05 Ram 1500 Pickup 4WD</b>												
0"	0"	H7019	H7017	----	N8019	N8017	----	B8519	B8517	----	M9519	M9517
2"		H7004		----	N8004		----	B8504		----	M9504	
5-6"	2-5"	H7091	H7036	----	N8091	N8036	----	B8591	B8536	----	M9591	M9536
<b>94-01 Ram 1500 Pickup 2WD</b>												
1-2.5"	0-1"	H7010	H7027	----	----	N8027	----	B8510	B8527	----	M9510	M9527
<b>94-01 Ram 1500 Pickup 4WD</b>												
0-1"	0"	H7091	H7027	----	N8091	N8027	----	B8591	B8527	----	M9591	M9527
2-3"	1-5"	H7092	H7017	----	N8092	N8017	----	B8592	B8517	----	M9592	M9517
4-5"	1-5"	H7093	H7017	----	N8093	N8017	----	B8593	B8517	----	M9593	M9517
<b>14-18 Ram 2500 4WD</b>												
0-1"	0-1"	H7091	H7091	----	----	N8091	----	----	B8591	----	----	M9591
2"	2"	H7091	H7092	----	N8091	N8092	----	B8591	B8592	----	M9591	M9592
4"	4"	H7092	H7093	----	N8092	N8093	----	B8592	B8593	----	M9592	----
6"	6"	H7093	H7094	----	N8093	N8094	----	B8593	B8594	----	M9593	----
<b>13-18 Ram 3500 4WD</b>												
0-1"	0-1"	H7091	H7070	----	----	N8070	----	----	B8570	----	----	M9570
2"	2-3"	H7091	H7036	----	N8091	N8036	----	B8591	B8536	----	M9591	M9536
4"	4"	H7092	H7090	----	N8092	N8090	----	B8592	B8590	----	M9592	M9590
6"	6"	H7093	H7090	----	N8093	N8090	----	B8593	B8590	----	M9593	M9590
<b>03-13 Ram 2500 Pickup 4WD</b>												
0"	0"	H7091	H7017	----	N8091	N8017	----	B8591	B8517	----	M9591	M9517
1-2.5"	1-4.5"	H7092	H7036	----	N8092	N8036	----	B8592	B8536	----	M9592	M9536
4-6"	1-4.5"	H7094	H7036	----	N8094	N8036	----	B8594	B8536	----	M9594	M9536
<b>03-12 Ram 3500 Pickup 4WD</b>												
0"	0"	H7091	H7017	----	N8091	N8017	----	B8591	B8517	----	M9591	M9517
1-2.5"	1-4.5"	H7092	H7036	----	N8092	N8036	----	B8592	B8536	----	M9592	M9536
4-6"	1-4.5"	H7094	H7036	----	N8094	N8036	----	B8594	B8536	----	M9594	M9536
<b>03-11 Ram 2500 / 3500 / Mega</b>												

# SHOCK APPLICATION GUIDE

Lift Height		HYDRO		Fact. Front	NITRO		Fact. Front	BLACK MAX		Fact. Front	MONOTUBE	
Front	Rear	Front	Rear	Dual	Front	Rear	Dual	Front	Rear	Dual	Front	Rear
<b>61-93 Ramcharger, Trailduster 4WD</b>												
0-1"	0-3.5"	H7047	H7038	----	N8047	N8038	----	B8547	B8538	----	M9547	M9538
1.5-3"	0-3.5"	H7027	H7038	----	N8027	N8038	----	B8527	B8538	----	M9527	M9538
4"	0-3.5"	H7017	H7038	----	N8017	N8038	----	B8517	B8538	----	M9517	M9538
5-6"	4-7"	H7017	H7068	----	N8017	N8068	----	B8517	B8568	----	M9517	M9568
7-8"	4-7"	H7036	H7068	----	N8036	N8068	----	B8536	B8568	----	M9536	M9568
<b>61-71 D200 3/4 Ton Pickup 2WD</b>												
0-2"	0-2"	H7017	H7058	----	N8017	N8058	----	B8517	B8558	----	M9517	M9558
<b>61-71 D300 1 Ton Pickup 2WD</b>												
0"	0"	H7017	H7012	----	N8017	N8012	----	B8517	B8512	----	M9517	M9512
<b>97-99 Dakota 4WD</b>												
0"	0"	H7052	H7058	----	N8052	N8058	----	B8552	B8558	----	M9552	M9558
3-4"	3-4"	H7054	H7017	----	N8054	N8017	----	B8554	B8517	----	M9554	M9517
<b>86-96 Dakota 4WD</b>												
0-1.5"	0"	H7052	H7029	----	N8052	N8029	----	B8552	B8529	----	M9552	M9529
2-4"	1-2"	H7054	H7029	----	N8054	N8029	----	B8554	B8529	----	M9554	M9529
<b>82-91 Ram D50 Mini 4WD</b>												
1-2"	0-2"	H7013	H7058	----	N8013	N8058	----	B8513	B8558	----	M9513	M9558
<b>79-92 Ram D50 Mini 2WD</b>												
1-2"	0-2"	H7013	H7012	----	N8013	N8012	----	B8513	B8512	----	M9513	M9512
<b>89-91 Raider 4WD with V6 Engine</b>												
1-2"	0-2"	H7013	H7012	----	N8013	N8012	----	B8513	B8512	----	M9513	M9512
<b>87-89 Raider 4WD with 4 Cylinder Engine</b>												
1-2"	0-2"	H7013	H7023	----	N8013	N8023	----	B8513	B8523	----	M9513	M9523
<b>79-82 Plymouth Arrow 4WD</b>												
1-2"	0-2"	H7013	H7023	----	N8013	N8023	----	B8513	B8523	----	M9513	M9523
<b>FORD</b>												
<b>04-18 F-150 4WD / 2WD</b>												
----	0"	----	H7041	----	----	N8041	----	----	B8541	----	----	M9541
----	1-4.5"	----	H7060	----	----	N8060	----	----	B8560	----	----	M9560
<b>97-03 F-150 &amp; SuperCrew 4WD</b>												
0-1"	0-2"	H7052	H7059	----	N8052	N8059	----	B8552	B8559	----	M9552	M9559
5-6"	3-5"	H7097	H7061	----	N8097	N8061	----	B8597	B8561	----	M9597	M9561
<b>80-96 F-150 4WD</b>												
0-2"	0-1"	H7052 <sup>(B)</sup>	H7058	H7055 <sup>(A)</sup>	N8052	N8058	N8055	B8552	B8558	B8555	M9552	M9558
3"	1.5-5"	H7054 <sup>(B)</sup>	H7060	H7055 <sup>(A)</sup>	N8054	N8060	N8055	B8554	B8560	B8555	M9554	M9560
4"	1.5-5"	H7054 <sup>(B)</sup>	H7060	H7057 <sup>(A)</sup>	N8054	N8060	N8057	B8554	B8560	B8557	M9554	M9560
5-6"	1.5-5"	H7055 <sup>(B)</sup>	H7060	H7057 <sup>(A)</sup>	N8055	N8060	N8057	B8555	B8560	B8557	M9555	M9560
7-8"	6-9"	H7055 <sup>(B)</sup>	H7079	H7057 <sup>(A)</sup>	N8055	N8079	N8057	B8555	B8579	B8557	M9555	M9579
<b>77-79 F-100, F-150 4WD</b>												
0-2"	0-1"	H7054 <sup>(A)</sup>	H7055	H7055 <sup>(B)</sup>	N8054 <sup>(A)</sup>	N8055	N8055 <sup>(B)</sup>	B8554 <sup>(A)</sup>	B8555	B8555 <sup>(B)</sup>	M9554 <sup>(A)</sup>	M9555
3-4"	1.5-2"	H7055 <sup>(A)</sup>	H7056	H7056 <sup>(B)</sup>	N8055 <sup>(A)</sup>	N8056	N8056 <sup>(B)</sup>	B8555 <sup>(A)</sup>	B8556	B8556 <sup>(B)</sup>	M9555 <sup>(A)</sup>	M9556
5-6"	3.5-4"	H7056 <sup>(A)</sup>	H7059	H7059 <sup>(B)</sup>	N8056 <sup>(A)</sup>	N8059	N8059 <sup>(B)</sup>	B8556 <sup>(A)</sup>	B8559	B8559 <sup>(B)</sup>	M9556 <sup>(A)</sup>	M9559
7-9"	5-8"	H7059 <sup>(A)</sup>	H7061	H7061 <sup>(B)</sup>	N8059 <sup>(A)</sup>	N8061	N8061 <sup>(B)</sup>	B8559 <sup>(A)</sup>	B8561	B8561 <sup>(B)</sup>	M9559 <sup>(A)</sup>	M9561
<b>70-76 F-100, F-150 4WD</b>												
0-1"	0-1"	H7012 <sup>(A)</sup>	H7055	H7055 <sup>(B)</sup>	N8012	N8055	N8055	B8512	B8555	B8555	M9512	M9555
1.5-4"	1.5-2"	H7023 <sup>(A)</sup>	H7056	H7056 <sup>(B)</sup>	N8023	N8056	N8056	B8523	B8556	B8556	M9523	M9556
5-6"	3.5-4"	H7058 <sup>(A)</sup>	H7059	H7059 <sup>(B)</sup>	N8058	N8059	N8059	B8558	B8559	B8559	M9558	M9559
7-9"	5-8"	H7060 <sup>(A)</sup>	H7061	H7061 <sup>(B)</sup>	N8060	N8061	N8061	B8560	B8561	B8561	M9560	M9561
<b>66-69 F-100, F-150 4WD</b>												
0-1"	0"	H7012	H7023	----	N8012	N8023	----	B8512	B8523	----	M9512	M9523
1.5-4"	1-3"	H7023	H7058	----	N8023	N8058	----	B8523	B8558	----	M9523	M9558
5-6"	3.5-4.5"	H7058	H7041	----	N8058	N8041	----	B8558	B8541	----	M9558	M9541
7-9"	5-8"	H7060	H7060	----	N8060	N8060	----	B8560	B8560	----	M9560	M9560
<b>97-03 F-150 2WD</b>												
0-1"	0"	H7013	H7056	----	N8013	N8056	----	B8513	B8556	----	M9513	M9556
<b>80-96 F-150 2WD</b>												
0-2"	0-3.5"	H7052 <sup>(B)</sup>	H7058	H7054 <sup>(A)</sup>	N8052	N8058	N8054	B8552	B8558	B8554	M9552	M9558
3"	0-3.5"	H7054 <sup>(B)</sup>	H7058	H7055 <sup>(A)</sup>	N8054	N8058	N8055	B8554	B8558	B8555	M9554	M9558
4"	0-3.5"	H7054 <sup>(B)</sup>	H7058	H7057 <sup>(A)</sup>	N8054	N8058	N8057	B8554	B8558	B8557	M9554	M9558
5-8"	4-8"	H7055 <sup>(B)</sup>	H7060	H7057 <sup>(A)</sup>	N8055	N8060	N8057	B8555	B8560	B8557	M9555	M9560
<b>70-79 F-100, F-150 2WD Except Crew Cab</b>												
0-1"	0-1"	H7052	H7054	----	N8052	N8054	----	B8552	B8554	----	M9552	M9554
2-3"	2-3"	H7054	H7055	----	N8054	N8055	----	B8554	B8555	----	M9554	M9555

# SHOCK APPLICATION GUIDE

Lift Height		HYDRO		Fact. Front	NITRO		Fact. Front	BLACK MAX		Fact. Front	MONOTUBE	
Front	Rear	Front	Rear	Dual	Front	Rear	Dual	Front	Rear	Dual	Front	Rear
<b>80-96 Bronco 4WD, 2WD</b>												
0-2"	0-3.5"	H7052 <sup>(B)</sup>	H7058	H7055 <sup>(A)</sup>	N8052	N8058	N8055	B8552	B8558	B8555	M9552	M9558
3"	0-3.5"	H7054 <sup>(B)</sup>	H7058	H7055 <sup>(A)</sup>	N8054	N8058	N8055	B8554	B8558	B8555	M9554	M9558
4"	0-3.5"	H7054 <sup>(B)</sup>	H7058	H7057 <sup>(A)</sup>	N8054	N8058	N8057	B8554	B8558	B8557	M9554	M9558
5-8"	4-8"	H7055 <sup>(B)</sup>	H7060	H7057 <sup>(A)</sup>	N8055	N8060	N8057	B8555	B8560	B8557	M9555	M9560
KIT NOTES: (A) Ahead of Axle (B) Behind Axle.												
<b>78-79 Bronco 4WD</b>												
0-2"	0-2"	H7055 <sup>(A)</sup>	H7023	H7055 <sup>(A)</sup>	N8055 <sup>(A)</sup>	N8023	N8055 <sup>(A)</sup>	B8555 <sup>(A)</sup>	B8523	B8555 <sup>(A)</sup>	M9555 <sup>(A)</sup>	M9523
		H7054 <sup>(B)</sup>		H7054 <sup>(B)</sup>	N8054 <sup>(B)</sup>		N8054 <sup>(B)</sup>	B8554 <sup>(B)</sup>		B8554 <sup>(B)</sup>	M9554 <sup>(B)</sup>	
3-5"	3.5-4.5"	H7056 <sup>(A)</sup>	H7058	H7056 <sup>(A)</sup>	N8056 <sup>(A)</sup>	N8058	N8056 <sup>(A)</sup>	B8556 <sup>(A)</sup>	B8558	B8556 <sup>(A)</sup>	M9556 <sup>(A)</sup>	M9558
		H7055 <sup>(B)</sup>		H7055 <sup>(B)</sup>	N8055 <sup>(B)</sup>		N8055 <sup>(B)</sup>	B8555 <sup>(B)</sup>		B8555 <sup>(B)</sup>	M9555 <sup>(B)</sup>	
6"	5-7"	H7059 <sup>(A)</sup>	H7058	H7059 <sup>(A)</sup>	N8059 <sup>(A)</sup>	N8058	N8059 <sup>(A)</sup>	B8559 <sup>(A)</sup>	B8558	B8559 <sup>(A)</sup>	M9559 <sup>(A)</sup>	M9558
		H7056 <sup>(B)</sup>		H7056 <sup>(B)</sup>	N8056 <sup>(B)</sup>		N8056 <sup>(B)</sup>	B8556 <sup>(B)</sup>		B8556 <sup>(B)</sup>	M9556 <sup>(B)</sup>	
7-9"	8-10"	H7061 <sup>(A)</sup>	H7060	H7061 <sup>(A)</sup>	N8061 <sup>(A)</sup>	N8060	N8061 <sup>(A)</sup>	B8561 <sup>(A)</sup>	B8560	B8561 <sup>(A)</sup>	M9561 <sup>(A)</sup>	M9560
		H7059 <sup>(B)</sup>		H7059 <sup>(B)</sup>	N8059 <sup>(B)</sup>		N8059 <sup>(B)</sup>	B8559 <sup>(B)</sup>		B8559 <sup>(B)</sup>	M9559 <sup>(B)</sup>	
<b>67-77 Bronco 4WD</b>												
0-1"	0"	H7054	H7012	----	N8054	N8012	----	B8554	B8512	----	M9554	M9512
2-3"	1-2.5"	H7055	H7023	----	N8055	N8023	----	B8555	B8523	----	M9555	M9523
4-6"	3.5-5"	H7055	H7058	----	N8055	N8058	----	B8555	B8558	----	M9555	M9558
6.5-8"	5.5-10"	H7056	H7060	----	N8056	N8060	----	B8556	B8560	----	M9556	M9560
<b>00-05 Excursion 4WD (Leaf Spring Front End)</b>												
0-3"	0"	H7023	H7034	----	N8023	N8034	----	B8523	B8534	----	M9523	M9534
4-6"	1-4.5"	H7041	H7034	----	N8041	N8034	----	B8541	B8534	----	M9541	M9534
7-8"	5.5-8"	H7060	H7077	----	N8060	N8077	----	B8560	B8577	----	M9560	M9577
<b>2017-18 F-250, F-350 Super Duty 4WD</b>												
0-3"	0"	H7091	H7038	----	N8091	N8038	----	B8591	B8538	----	M9591	M9538
4"	2-4.5"	H7092	H7068	----	N8092	N8068	----	B8592	B8568	----	M9592	M9568
6"	2-4.5"	H7093	H7068	----	N8093	N8068	----	B8593	B8568	----	M9593	M9568
8.5"	5.5-7.5"	H7094	H7089	----	N8094	N8089	----	B8594	B8589	----	M9594	M9589
<b>05-16 F-250 Super Duty 4WD</b>												
0-3"	0-3"	H7091	H7060	----	N8091	N8060	----	B8591	B8560	----	M9591	M9560
3.5-5"	3.5-5"	H7092	H7060	----	N8092	N8060	----	B8592	B8560	----	M9592	M9560
6-7"	6-7"	H7093	H7079	----	N8093	N8079	----	B8593	B8579	----	M9593	M9579
8.5"	8.5"	H7094	H7099	----	N8094	N8099	----	B8594	B8599	----	M9594	M9599
<b>05-16 F-350 Super Duty 4WD</b>												
0-3"	0-3"	H7091	H7060	----	N8091	N8060	----	B8591	B8560	----	M9591	M9560
3.5-5"	3.5-5"	H7092	H7079	----	N8092	N8060	----	B8592	B8560	----	M9592	M9560
6-7"	6-7"	H7093	H7079	----	N8093	N8079	----	B8593	B8579	----	M9593	M9579
8.5"	8.5"	H7094	H7099	----	N8094	N8099	----	B8594	B8599	----	M9594	M9599
<b>99-04 F-250, F-350 Super Duty 4WD</b>												
0-3"	0-1"	H7023	H7060	----	N8023	N8060	----	B8523	B8560	----	M9523	M9560
4-5"	2-7"	H7041	H7079	----	N8041	N8079	----	B8541	B8579	----	M9541	M9579
6-8"	2-7"	H7060	H7079	----	N8060	N8079	----	B8560	B8579	----	M9560	M9579
<b>05-16 F-250, F-350 Super Duty 2WD</b>												
0-1"	0"	H7052	H7041	----	N8052	N8041	----	B8552	B8541	----	M9552	M9541
2-4"	1-4"	H7054	H7060	----	N8054	N8060	----	B8554	B8560			

# SHOCK APPLICATION GUIDE

Lift Height		HYDRO		Fact. Front	NITRO		Fact. Front	BLACK MAX		Fact. Front	MONOTUBE	
Front	Rear	Front	Rear	Dual	Front	Rear	Dual	Front	Rear	Dual	Front	Rear
<b>66-77 F-250 4WD High Boy</b>												
----	0-4"	----	H7058	----	----	N8058	----	----	B8558	----	----	M9558
2-4"	0-4"	----	H7058	----	N8014	N8058	----	B8514	B8558	----	M9514	M9558
<b>97-98 F-250 Light Duty 2WD</b>												
3-6"	1.5-5"	H7041	H7060	----	N8041	N8060	----	B8541	B8560	----	M9541	M9560
<b>80-96 F-250 2WD</b>												
0-2"	0-2"	H7052	H7058	----	N8052	N8058	----	B8552	B8558	----	M9552	M9558
3-4"	0-2"	H7054	H7058	----	N8054	N8058	----	B8554	B8558	----	M9554	M9558
5-8"	3-4.5"	H7055	H7041	----	N8055	N8041	----	B8555	B8541	----	M9555	M9541
<b>86-98 F-350 4WD with Straight Axle</b>												
0-2"	0-4"	H7023	H7060	----	N8023	N8060	----	B8523	B8560	----	M9523	M9560
3-4"	0-4"	H7041	H7060	----	N8041	N8060	----	B8541	B8560	----	M9541	M9560
5-6"	0-4"	H7060	H7060	----	N8060	N8060	----	B8560	B8560	----	M9560	M9560
<b>80-85 F-350 4WD with IFS</b>												
0-2"	0-1"	H7054	H7058	----	N8054	N8058	----	B8554	B8558	----	M9554	M9558
3-6"	1.5-5"	H7055	H7060	----	N8055	N8060	----	B8555	B8560	----	M9555	M9560
<b>79 F-350 4WD</b>												
1-2"	1-3"	----	H7056	----	----	N8056	----	----	B8556	----	----	M9556
3-4"	1-3"	----	H7056	----	N8014	N8056	----	B8514	B8556	----	M9514	M9556
5-7"	4-6"	----	H7059	----	N8014	N8059	----	B8514	B8559	----	M9514	M9559
<b>80-96 F-350 2WD</b>												
0-2"	0-2"	H7052	H7058	----	N8052	N8058	----	B8552	B8558	----	M9552	M9558
3-4"	0-2"	H7054	H7058	----	N8054	N8058	----	B8554	B8558	----	M9554	M9558
5-8"	3-4.5"	H7055	H7041	----	N8055	N8041	----	B8555	B8541	----	M9555	M9541
<b>83-97 Ranger &amp; Splash 4WD</b>												
0-2"	0-1"	H7052	H7058	----	N8052	N8058	----	B8552	B8558	----	M9552	M9558
3"	0-1"	H7054	H7058	----	N8054	N8058	----	B8554	B8558	----	M9554	M9558
4"	1.5-4.5"	H7054	H7060	----	N8054	N8060	----	B8554	B8560	----	M9554	M9560
5-6"	1.5-4.5"	H7055	H7060	----	N8055	N8060	----	B8555	B8560	----	M9555	M9560
7-8"	5-6"	H7055	H7079	----	N8055	N8079	----	B8555	B8579	----	M9555	M9579
<b>83-97 Ranger 2WD &amp; Bronco II 4WD, 2WD</b>												
0-2"	0-3.5"	H7052	H7058	----	N8052	N8058	----	B8552	B8558	----	M9552	M9558
3-4"	0-3.5"	H7054	H7058	----	N8054	N8058	----	B8554	B8558	----	M9554	M9558
5-8"	4-8"	H7055	H7060	----	N8055	N8060	----	B8555	B8560	----	M9555	M9560
<b>90-94 Explorer 4WD, 2WD</b>												
0-2"	0-2"	H7052	H7029	----	N8052	N8029	----	B8552	B8529	----	M9552	M9529
3-4"	3-6"	H7054	H7034	----	N8054	N8034	----	B8554	B8534	----	M9554	M9534
5-6"	3-6"	H7055	H7034	----	N8055	N8034	----	B8555	B8534	----	M9555	M9534
<b>HONDA</b>												
<b>94-95 Passport 4WD</b>												
0"	0"	H7052	H7055	----	N8052	N8055	----	B8552	B8555	----	M9552	M9555
<b>ISUZU</b>												
<b>05-08 Isuzu i-Sries 4WD</b>												
3-5"	3-4"	H7040	H7084	----	N8040	N8074	----	B8540	B8574	----	M9540	M9574
<b>89-95 Amigo 4WD, 2WD</b>												
0-1"	0"	H7052	H7023	----	N8052	N8023	----	B8552	B8523	----	M9552	M9523
<b>87-91 Trooper II 4WD</b>												
0-1"	0"	H7052	H7055	----	N8052	N8055	----	B8552	B8555	----	M9552	M9555
<b>84-86 Trooper II 4WD</b>												
0-1"	0"	H7052	H7023	----	N8052	N8023	----	B8552	B8523	----	M9552	M9523
<b>81-92 Pickup 4WD</b>												
1-2"	0-1"	H7052	H7012	----	N8052	N8012	----	B8552	B8512	----	M9552	M9512
<b>91-95 Pickup 2WD</b>												
0"	0"	H7052	H7023	----	N8052	N8023	----	B8552	B8523	----	M9552	M9523
<b>JEEP</b>												
<b>07-18 Wrangler JK 2 &amp; 4 Door 4WD</b>												
(-2)-(-2.5)"	(-2)-(-2.5)"	----	----	----	N8005	N8007	----	----	B8507	----	----	----
0-1"	0-1"	H7001	H7007	----	N8001	N8007	----	B8501	B8507	----	M9501	M9507
1-2.5"	2-3.5"	H7035	H7037	----	N8035	N8037	----	B8535	B8537	----	M9535	M9537
3-5"	4-5"	H7065	H7067	----	N8065	N8067	----	B8565	B8567	----	M9565	M9567
6-7"	6-7"	H7075	H7087	----	N8075	N8087	----	B8575	B8587	----	M9575	M9587
<b>97-06 Wrangler TJ / Unlimited / Rubicon 4WD (TJ Rear Shock Relocation Brackets Available, Part # TJRSB10)</b>												
0-3"	0"	H7016	H7008	----	N8016	N8008	----	B8516	B8508	----	M9516	M9508
0-3"	1-3"	H7016	H7018	----	N8016	N8018	----	B8516	B8518	----	M9516	M9518
3.5-4"	3.5-4"	H7025	H7028	----	N8025	N8028	----	B8525	B8528	----	M9525	M9528
6-9"	6-8"	H7049	H7063	----	N8049	N8063	----	B8549	B8563	----	M9549	M9563
<b>87-96 Wrangler YJ 4WD</b>												
0-1"	0"	H7055	H7012	----	N8055	N8012	----	B8555	B8512	----	M9555	M9512

# SHOCK APPLICATION GUIDE

Lift Height		HYDRO		Fact. Front	NITRO		Fact. Front	BLACK MAX		Fact. Front	MONOTUBE	
Front	Rear	Front	Rear	Dual	Front	Rear	Dual	Front	Rear	Dual	Front	Rear
2-2.5"	1-2.5"	H7056	H7023	----	N8056	N8023	----	B8556	B8523	----	M9556	M9523
3.5-4"	3-6"	H7059	H7088	----	N8059	N8088	----	B8559	B8588	----	M9559	M9588
5-6"	3-6"	H7061	H7088	----	N8061	N8088	----	B8561	B8588	----	M9561	M9588
<b>82-86 CJ5, CJ7 &amp; Scrambler 4WD</b>												
0-2.5"	0-2.5"	H7012	H7023	----	N8012	N8023	----	B8512	B8523	----	M9512	M9523
3-5"	3-5"	H7023	H7058	----	N8023	N8058	----	B8523	B8558	----	M9523	M9558
<b>76-81 CJ5, CJ7 &amp; Scrambler 4WD</b>												
0-2.5"	0"	H7012	H7012	----	N8012	N8012	----	B8512	B8512	----	M9512	M9512
0-2.5"	1-3"	H7012	H7023	----	N8012	N8023	----	B8512	B8523	----	M9512	M9523
3-5"	1-3"	H7023	H7023	----	N8023	N8023	----	B8523	B8523	----	M9523	M9523
3-5"	3.5-5.5"	H7023	H7058	----	N8023	N8058	----	B8523	B8558	----	M9523	M9558
<b>55-75 CJ5, CJ6, 3B &amp; M38A1 4WD</b>												
0-1"	0"	H7012	H7012	----	N8012	N8012	----	B8512	B8512	----	M9512	M9512
1.5-2.5"	1-3"	H7023	H7023	----	N8023	N8023	----	B8523	B8523	----	M9523	M9523
3-5"	3.5-5.5"	H7058	H7058	----	N8058	N8058	----	B8558	B8558	----	M9558	M9558
<b>41-63 MB, M38, CJ2A, CJ3A &amp; CJ3B 4WD</b>												
0-1"	0-1"	H7012	H7012	----	N8012	N8012	----	B8512	B8512	----	M9512	M9512
<b>All U.S. Post Office Jeep FJ8A &amp; FJ9 2WD</b>												
0"	0"	H7012	H7012	----	N8012	N8012	----	B8512	B8512	----	M9512	M9512
<b>02-12 Liberty KJ 4WD, 2WD</b>												
----	2.5"	----	H7088	----	----	N8088	----	----	B8588	----	----	M9588
<b>84-01 Cherokee XJ 4WD, 2WD</b>												
0-3"	0"	H7016	H7008	----	N8016	N8008	----	B8516	B8508	----	M9516	M9508
0-3"	1-3"	H7016	H7018	----	N8016	N8018	----	B8516	B8518	----	M9516	M9518
4-5"	4-5"	H7025	H7028	----	N8025	N8028	----	B8525	B8528	----	M9525	M9528
6-8"	5-8"	H7049	H7063	----	N8049	N8063	----	B8549	B8563	----	M9549	M9563
<b>06-10 Commander XK 4WD, 2WD</b>												
----	0-2"	----	H7088	----	----	N8088	----	----	B8588	----	----	M9588
<b>05-10 Grand Cherokee WK 4WD, 2WD</b>												
----	0-2"	----	H7088	----	----	N8088	----	----	B8588	----	----	M9588
<b>99-04 Grand Cherokee WJ 4WD, 2WD</b>												
0"	0"	H7015	H7042	----	N8015	N8042	----	B8515	B8542	----	M9515	M9542
2-3"	2-3"	H7016	H7044	----	N8016	N8044	----	B8516	B8544	----	M9516	M9544
<b>93-98 Grand Cherokee ZJ 4WD, 2WD</b>												
0-3"	0-3"	H7016	H7023	----	N8016	N8023	----	B8516	B8523	----	M9516	M9523
4-5"	4-5"	H7025	H7058	----	N8025	N8058	----	B8525	B8558	----	M9525	M9558
<b>84-91 Grand Wagoneer 4WD - Full-Size</b>												
0-1"	0-1"	H7012	H7012	----	N8012	N8012	----	B8512	B8512	----	M9512	M9512
2-3"	2-3"	H7023	H7023	----	N8023	N8023	----	B8523	B8523	----	M9523	M9523
4-5"	4-5"	H7088	H7088	----	N8088	N8088	----	B8588	B8588	----	M9588	M9588
<b>74-83 Cherokee, Wagoneer 4WD - Full-Size</b>												
0-1"	0-1"	H7012	H7012	----	N8012	N8012	----	B8512	B8512	----	M9512	M9512
2-3"	2-3"	H7023	H7023	----	N8023	N8023	----	B8523	B8523	----	M9523	M9523
4-5"	4-5"	H7088	H7088	----	N8088	N8088	----	B8588	B8588	----	M9588	M9588
<b>86-92 Comanche MJ 4WD, 2WD</b>												
0-3"	0-3"	H7016	H7023	----	N8016	N8023	----	B8516	B8523	----	M9516	M9523
4-5"	4-5"	H7025	H7058	----	N8025	N8058	----	B8525	B8558	----	M9525	M9558
<b>74-88 J10, J20 Pickup 4WD</b>												
0-1"	0-1"	H7012	H7012	----	N8012	N8012	----	B8512	B8512	----	M9512	M9512
2-3"	2-3"	H7023	H7023	----	N8023	N8023	----	B8523	B8523	----	M9523	M9523
<b>74-88 J10, J20 Pickup 4WD</b>												
4-5"	4-5"	H7088	H7088	----	N8088	N8088	----	B8588	B8588	----	M9588	M9588
<b>63-73 Wagoneer 4WD</b>												
2-3"	2-4"	H7058	H7023	----	N8058	N8023	----	B8558	B8523	----	M9558	M9523
<b>69-73 Jeepster, C101 &amp; Commando 4WD</b>												
0-2"	0-2"	H7012	H7023	----	N8012	N8023	----	B8512	B8523	----	M9512	M9523
3-4"	3-4"	H7023	H7058	----	N8023	N8058	----	B8523	B8558	----	M9523	M9558
<b>47-62 Utility Wagon 4WD</b>												
2-4"	2-4"	H7012	H7023	----	N8012	N8023	----	B8512				

# SHOCK APPLICATION GUIDE

Lift Height		HYDRO		Fact. Front	NITRO		Fact. Front	BLACK MAX		Fact. Front	MONOTUBE	
Front	Rear	Front	Rear	Dual	Front	Rear	Dual	Front	Rear	Dual	Front	Rear
<b>MAZDA</b>												
<b>94-97 B4000 4WD</b>												
0-2"	0-4"	H7052	H7060	----	N8052	N8060	----	B8552	B8560	----	M9552	M9560
3-4"	0-4"	H7054	H7060	----	N8054	N8060	----	B8554	B8560	----	M9554	M9560
5-6"	0-4"	H7055	H7060	----	N8055	N8060	----	B8555	B8560	----	M9555	M9560
<b>87-93 B2600 4WD</b>												
0-2"	0-1"	H7052	H7027	----	N8052	N8027	----	B8552	B8527	----	M9552	M9527
<b>90-94 Navajo 4WD</b>												
0-2"	0-2"	H7052	H7029	----	N8052	N8029	----	B8552	B8529	----	M9552	M9529
3-4"	3-8"	H7054	H7039	----	N8054	N8039	----	B8554	B8539	----	M9554	M9539
5-8"	3-8"	H7055	H7039	----	N8055	N8039	----	B8555	B8539	----	M9555	M9539
<b>94-97 B Series 2WD</b>												
0-2"	0-3.5"	H7052	H7058	----	N8052	N8058	----	B8552	B8558	----	M9552	M9558
3-4"	0-3.5"	H7054	H7058	----	N8054	N8058	----	B8554	B8558	----	M9554	M9558
5-8"	4-8"	H7055	H7060	----	N8055	N8060	----	B8555	B8560	----	M9555	M9560
<b>86-93 B-2000 &amp; B-2200 2WD</b>												
0-2"	0"	H7052	H7012	----	N8052	N8012	----	B8552	B8512	----	M9552	M9512
<b>MITSUBISHI</b>												
<b>85-89 Montero 4WD with 4 Cylinder Engine</b>												
1-2"	1-2"	H7013	H7023	----	N8013	N8023	----	B8513	B8523	----	M9513	M9523
<b>83-84 Montero 4WD</b>												
1-2"	1-2"	H7013	H7023	----	N8013	N8023	----	B8513	B8523	----	M9513	M9523
<b>83-91 Pickup 4WD</b>												
1-2"	1-2"	H7013	H7058	----	N8013	N8058	----	B8513	B8558	----	M9513	M9558
<b>NISSAN</b>												
<b>86.5-93 Pathfinder &amp; Terrano 4WD, 2WD</b>												
0-1"	0-1"	H7052	H7023	----	N8052	N8023	----	B8552	B8523	----	M9552	M9523
2-4"	2-4"	H7054	H7041	----	N8054	N8041	----	B8554	B8541	----	M9554	M9541
<b>86.5-92 Hardbody 4WD</b>												
2-3"	1-2"	H7052	H7023	----	N8052	N8023	----	B8552	B8523	----	M9552	M9523
4-5"	3-4"	H7054	H7058	----	N8054	N8058	----	B8554	B8558	----	M9554	M9558
<b>83.5-86 Pickup 4WD</b>												
1-2"	0-1"	H7052	H7023	----	N8052	N8023	----	B8552	B8523	----	M9552	M9523
<b>87-93 Pickup 2WD</b>												
1-2"	0-1"	H7052	H7023	----	N8052	N8023	----	B8552	B8523	----	M9552	M9523
<b>SCOUT</b>												
<b>72-82 Scout II, Terra &amp; Traveler 4WD</b>												
0-1"	0-1"	H7054	H7012	----	N8054	N8012	----	B8554	B8512	----	M9554	M9512
2-4"	2-4"	H7055	H7058	----	N8055	N8058	----	B8555	B8558	----	M9555	M9558
<b>61-71 Scout 80 &amp; 800 4WD</b>												
0-1"	0-1"	H7012	H7054	----	N8012	N8054	----	B8512	B8554	----	M9512	M9554
<b>SUZUKI</b>												
<b>85-92 Samurai / Santana 4WD</b>												
0-2"	0-2"	H7052	H7012	----	N8052	N8012	----	B8552	B8512	----	M9552	M9512
3-4"	3-4"	H7054	H7023	----	N8054	N8023	----	B8554	B8523	----	M9554	M9523
<b>85-88 LJ10, SJ10 &amp; LJ413 4WD</b>												
0-1"	0-1"	H7054	H7012	----	N8054	N8012	----	B8554	B8512	----	M9554	M9512
<b>82-85 LJ413 4WD</b>												
0-1"	0-1"	H7052	H7012	----	N8052	N8012	----	B8552	B8512	----	M9552	M9512
<b>TOYOTA</b>												
<b>05-14 HiLux / Tiger / Vigo 4WD</b>												
----	0-1.5"	----	H7027	----	----	N8027	----	----	B8527	----	----	M9527
<b>05-18 Tacoma 4WD &amp; Pre-Runner 2WD</b>												
----	0-1"	----	H7048	----	----	N8048	----	----	B8548	----	----	M9548
----	1.5-3"	----	H7045	----	----	N8045	----	----	B8545	----	----	M9545
<b>95.5-04 Tacoma 4WD &amp; Pre-Runner 2WD</b>												
----	0-1"	----	H7047	----	----	N8047	----	----	B8547	----	----	M9547
----	2-4"	----	H7027	----	----	N8027	----	----	B8527	----	----	M9527
<b>07-18 Tundra 4WD / 2WD</b>												
----	0-2"	----	H7062	----	----	N8062	----	----	B8562	----	----	M9562
----	4-5"	----	H7066	----	----	N8066	----	----	B8566	----	----	M9566
<b>00-06 Tundra 4WD</b>												
----	1-2.5"	----	H7048	----	----	N8048	----	----	B8548	----	----	M9548

# SHOCK APPLICATION GUIDE

Lift Height		HYDRO		Fact. Front	NITRO		Fact. Front	BLACK MAX		Fact. Front	MONOTUBE	
Front	Rear	Front	Rear	Dual	Front	Rear	Dual	Front	Rear	Dual	Front	Rear
<b>93-98 T100 4WD</b>												
0-2"	0-1"	H7002	H7058	----	N8002	N8058	----	B8502	B8558	----	M9502	M9558
3-4"	2-4"	H7004	H7060	----	N8004	N8060	----	B8504	B8560	----	M9504	M9560
<b>86-95 Pickup 4WD</b>												
0-2"	0-2"	H7002	H7047	----	N8002	N8047	----	B8502	B8547	----	M9502	M9547
3-4"	3-4"	H7004	H7027	----	N8004	N8027	----	B8504	B8527	----	M9504	M9527
<b>84-85 Pickup 4WD</b>												
0-1"	0-1"	H7052	H7047	----	N8052	N8047	----	B8552	B8547	----	M9552	M9547
1.5-2.5"	0-1"	H7054	H7047	----	N8054	N8047	----	B8554	B8547	----	M9554	M9547
3-4"	1.5-3.5"	H7055	H7027	----	N8055	N8027	----	B8555	B8527	----	M9555	M9527
5-6"	4-8.5"	H7055	H7036	----	N8055	N8036	----	B8555	B8536	----	M9555	M9536
7-8"	4-8.5"	H7056	H7036	----	N8056	N8036	----	B8556	B8536	----	M9556	M9536
<b>79-83 Pickup 4WD</b>												
0-1"	0-2"	H7052	H7058	----	N8052	N8058	----	B8552	B8558	----	M9552	M9558
1.5-2.5"	0-2"	H7054	H7058	----	N8054	N8058	----	B8554	B8558	----	M9554	M9558
3-4"	0-2"	H7055	H7058	----	N8055	N8058	----	B8555	B8558	----	M9555	M9558
5-6"	3-7"	H7055	H7060	----	N8055	N8060	----	B8555	B8560	----	M9555	M9560
7-8"	3-7"	H7056	H7060	----	N8056	N8060	----	B8556	B8560	----	M9556	M9560
<b>03-18 4Runner 4WD / 2WD</b>												
----	2-3"	----	H7098	----	----	N8098	----	----	B8598	----	----	M9598
<b>96-01 4Runner 4WD</b>												
----	0-2.5"	----	H7022	----	----	N8022	----	----	B8522	----	----	M9522
<b>90-95 4Runner 4WD, 2WD</b>												
0-2"	0-2"	H7002	H7022	----	N8002	N8022	----	B8502	B8522	----	M9502	M9522
3-4"	3-4"	H7004	H7024	----	N8004	N8024	----	B8504	B8524	----	M9504	M9524
<b>86-89 4Runner 4WD</b>												
0-2"	0-2"	H7002	H7047	----	N8002	N8047	----	B8502	B8547	----	M9502	M9547
3-4"	3-4"	H7004	H7027	----	N8004	N8027	----	B8504	B8527	----	M9504	M9527
<b>84-85 4Runner 4WD</b>												
0-1"	0-1"	H7052	H7047	----	N8052	N8047	----	B8552	B8547	----	M9552	M9547
1.5-2.5"	0-1"	H7054	H7047	----	N8054	N8047	----	B8554	B8547	----	M9554	M9547
3-4"	1.5-3.5"	H7055	H7027	----	N8055	N8027	----	B8555	B8527	----	M9555	M9527
5-6"	4-8.5"	H7055	H7036	----	N8055	N8036	----	B8555	B8536	----	M9555	M9536
7-8"	4-8.5"	H7056	H7036	----	N8056	N8036	----	B8556	B8536	----	M9556	M9536
<b>07-14 FJ Cruiser 4WD</b>												
----	1.5"-2.5"	----	H7098	----	----	N8098	----	----	B8598	----	----	M9598
<b>84-87 LandCruiser 60 Series 4WD (Model FJ60)</b>												
0"	0"	H7091	H7047	----	N8091	N8047	----	B8591	B8547	----	M9591	M9547
<b>81-83 LandCruiser 60 Series 4WD (Model FJ60)</b>												
0"	0"	H7091	H7023	----	N8091	N8023	----	B8591	B8523	----	M9591	M9523
<b>84-89 LandCruiser BJ70, BJ71, BJ73 &amp; BJ75 4WD</b>												
0-1"	0-1"	H7091	H7047	----	N8091	N8047	----	B8591	B8547	----	M9591	M9547
<b>91-97 LandCruiser FJ80 4WD</b>												
----	0-2"	----	H7024	----	----	N8024	----	----	B8524	----	----	M9524
<b>86-89 LandCruiser FJ60 4WD</b>												
0-2"	0-2"	H7022	H7047	----	N8022	N8047	----	B8522	B8547	----	M9522	M9547
<b>88-89 LandCruiser HJ40 4WD</b>												
0"	0"	H7091	H7047	----	N8091	N8047	----	B8591	B8547	----	M9591	M9547
<b>64-84 LandCruiser FJ40, BJ40 &amp; BJ42 4WD</b>												
0-2"	0-2"	H7012	H7023	----	N8012	N8023	----	B8512	B8523	----	M9512	M9523
3-4"	3-4"	H7023	H7041	----	N8023	N8041	----	B8523	B8541	----	M9523	M9541
5-6"	5-6"	H7023	H7060	----	N8023	N8060	----	B8523	B8560	----	M9523	M9560
<b>94-95 LandCruiser KZJ70 &amp; KZJ73 4WD</b>												
0"	0"	H7091	H7047	----	N8091	N8047	----	B8591	B8547	----	M9591	M9547
<b>90-93 LandCruiser LJ70 &amp; LJ73 4WD</b>												
0"	0"	H7091	H7047	----	N8091	N8047	----	B8591	B8547	----	M9591	M9547
<b>64-81 Wagon FJ43 &amp; FJ45 4WD</b>												
0-1.5"	0-1.5"	H7012	H7023	----	N8012	N8023	----	B8512	B8523	----	M9512	M9523

# FRONT LEVELING STRUTS

Year	Make / Model	Height (in.)		Front Strut (Single)	Rear Lift	Rear Shocks			
		Front	Rear			Hydro	Nitro	BLACK Max	M95
NOTES: Struts Sold Individually. Order (2) for Pair. Shocks Sold Individually. Order (2) for Pair.									
<b>DODGE</b>									
06-18	Dodge Ram 1500 4WD	1.5-2.5"	-----	D6912STS	-----	H7017	N8017	B8517	M9517
NOTES: Will NOT Fit TRX or Air Ride.									
<b>FORD</b>									
09-13	F-150 Pickup 4WD	1-2.5"	-----	F9125STS	-----	H7041	N8041	B8541	M9541
09-13	F-150 Pickup 2WD	2-2.5"	-----	F9125STS	-----	H7041	N8041	B8541	M9541
04-08	F-150 Pickup 4WD	2-3"	-----	F223STS	-----	H7041	N8041	B8541	M9541
04-08	F-150 Pickup 2WD	2-3"	-----	F423STS	-----	H7041	N8041	B8541	M9541
<b>LINCOLN</b>									
06-08	Mark LT 4WD	2-2.5"	-----	F9125STS	-----	H7041	N8041	B8541	M9541
<b>TOYOTA</b>									
07-14	FJ Cruiser 4WD	1-3"	-----	FJ713STS	-----	-----	-----	-----	-----
07-18	Tundra Pickup 2WD / 4WD	1-3"	-----	TU713STS	-----	H7062	N8062	B8562	M9562
00-06	Tundra Pickup 4WD	1-3"	-----	TT413STS	-----	-----	-----	-----	-----
05-18	Tacoma 4WD & Pre-Runner 2WD	1-3"	-----	TC513STS	-----	H7048	N8048	B8548	M9548
95.5-04	Tacoma 4WD & Pre-Runner 2WD	1-3"	-----	TT413STS	-----	H7047	N8047	B8547	M9547
03-18	4Runner 2WD / 4WD	1-3"	-----	TC513STS	-----	-----	-----	-----	-----
05-16	HiLux / Tiger / Vigo 4WD	1-3"	-----	HL13STS	-----	H7047	N8048	B8547	M9547

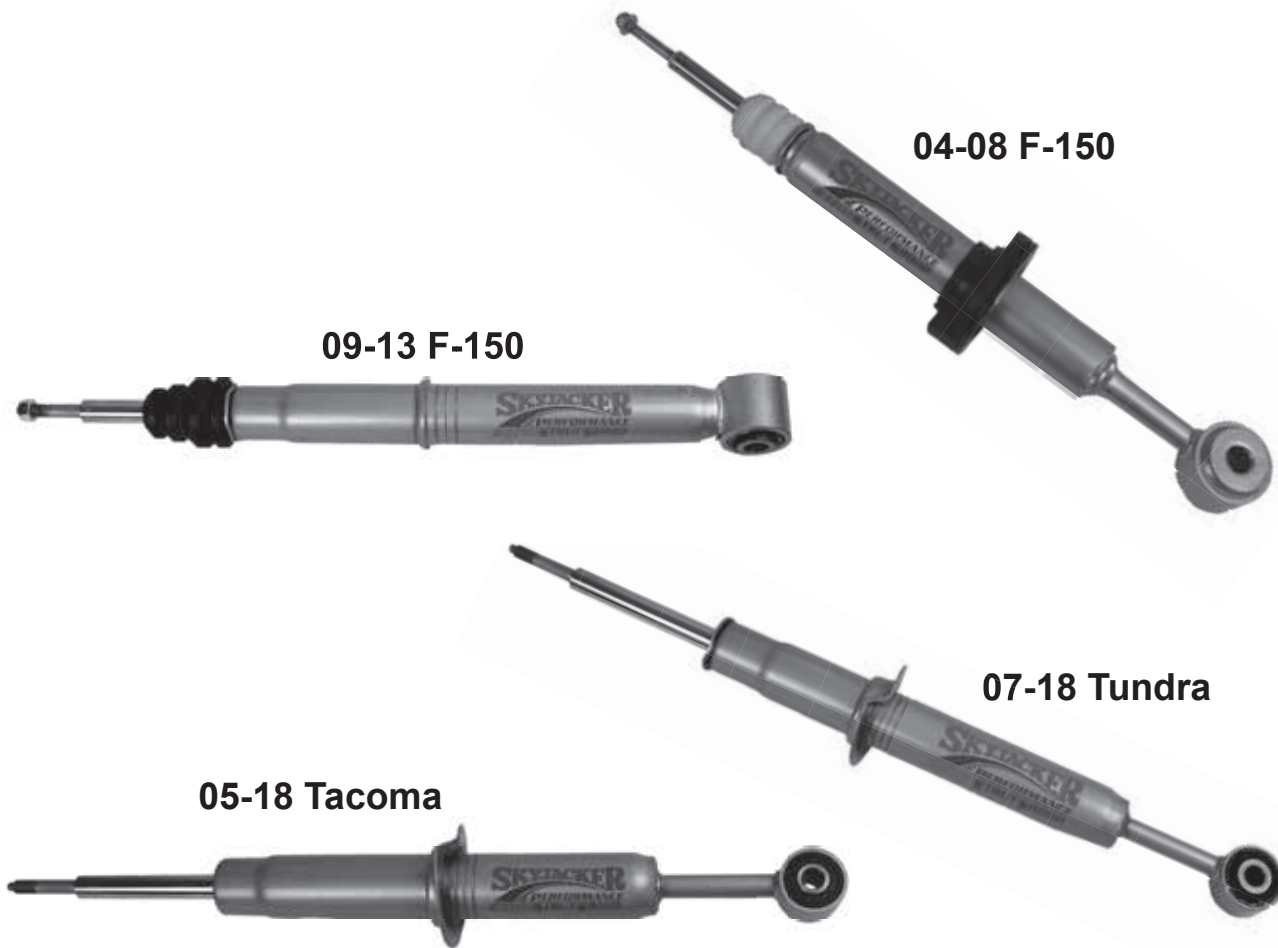

# FRONT MULTIPLE SHOCK APPLICATION GUIDE

LIFT	TYPE	PART #	QTY.	HYDRO	BLACK MAX	NOTES
NOTES: ALL SHOCKS MUST BE ORDERED SEPARATELY.						
<b>CHEVROLET / GMC</b>						
<b>67-91 1500, 2500, &amp; 3500 Pickup, Blazer, Jimmy &amp; Suburban 4WD</b>						
0-1.5"	Dual Front	DS250	2	H7021	B8521	
2-5"	Dual Front	DS250	2	H7051	B8551	
6-8"	Dual Front	DS250	2	H7071	B8571	
9-12"	Dual Front	DS250	2	H7032	B8532	
<b>DODGE</b>						
<b>03-13 2500 / 03-12 3500 Ram Pickup 4WD</b>						
0"	Dual Front	DS393	2	H7023	B8523	
2.5"	Dual Front	DS393	2	H7058	B8558	
4.5-5"	Dual Front	DS393	2	H7041	B8541	
<b>94-01 1/2 &amp; 3/4 Ton Ram Pickup 4WD</b>						
0-1"	Dual Front	DS390	2	H7023	B8523	
2-3"	Dual Front	DS390	2	H7023	B8523	
4-6"	Dual Front	DS390	2	H7058	B8558	
7"	Dual Front	DS390	2	H7041	B8541	
<b>94-01 3/4 HD &amp; 1 Ton Ram Pickup</b>						
0-1"	Dual Front	DS390	2	H7023	B8523	
1.5-3"	Dual Front	DS390	2	H7058	B8558	
4-5"	Dual Front	DS390	2	H7041	B8541	
7"	Dual Front	DS390	2	H7060	B8560	
<b>74.5-93 1/2, 3/4 &amp; 1 Ton Pickup, 74.5-93 Ramcharger / Trailduster 4WD</b>						
0-1"	Dual Front	DS350	2	H7023	B8523	
1.5-3"	Dual Front	DS350	2	H7058	B8558	
4-6"	Dual Front	DS350	2	H7041	B8541	
7-8"	Dual Front	DS350	2	H7060	B8560	
<b>FORD</b>						
<b>80-96 F-100, F-150 &amp; Bronco 4WD</b>						
0-2"	Dual Front	DS280	2	H7052	B8552	
3-4"	Dual Front	DS280	2	H7054	B8554	
5-8"	Dual Front	DS280	2	H7055	B8555	
<b>80-96 F-250, F-350 2WD</b>						
0-2"	Dual Front	DS280	2	H7052	B8552	
3-4"	Dual Front	DS280	2	H7054	B8554	
5-8"	Dual Front	DS280	2	H7055	B8555	
<b>77-79 F-100, F-150 4WD</b>						
0-2"	Dual Front	DS260	2	H7054	B8554	
3-4"	Dual Front	DS260	2	H7055	B8555	
5-6"	Dual Front	DS260	2	H7056	B8556	
7-9"	Dual Front	DS260	2	H7059	B8559	
<b>70-76 F-100, F-150 4WD</b>						
0-1"	Dual Front	DS260	2	H7052	B8552	
1.5-2"	Dual Front	DS260	2	H7054	B8554	
2.5-4"	Dual Front	DS260	2	H7055	B8555	
5-6"	Dual Front	DS260	2	H7055	B8555	
7-9"	Dual Front	DS260	2	H7061	B8561	
<b>00-05 Excursion 4WD &amp; 99-04 F-250 &amp; F-350 Super Duty 4WD</b>						
0-3"	Triple Front	TS950	4	H7012	B8512	A9
4-5"	Triple Front	TS950	4	H7058	B8558	A9
6-8"	Triple Front	TS950	4	H7041	B8541	A9
KIT NOTES: A9. This Kit Adds 2 Shocks Per Side & Requires the Use of OEM Position Front Shock.						

LIFT	TYPE	PART #	QTY.	HYDRO	BLACK MAX	NOTES
<b>87-98 F-250 4WD - IFS</b>						
0-2"	Triple Front	TS450	4	H7012	B8512	
3-6"	Triple Front	TS450	4	H7058	B8558	
<b>80-86 F-250 4WD - IFS</b>						
0-2"	Triple Front	TS450	4	H7012	B8512	
3-6"	Triple Front	TS450	4	H7023	B8523	
<b>77.5-79 F-250 4WD</b>						
4-7"	Dual Front	DS300	2	N8014	B8514	
<b>66-77 F-250 High Boy 4WD</b>						
2-4"	Dual Front	DS310	2	N8014	B8514	
<b>80-96 F-250 &amp; F-350 2WD</b>						
0-2"	Dual Front	DS280	2	H7052	B8552	
3-4"	Dual Front	DS280	2	H7054	B8554	
5-8"	Dual Front	DS280	2	H7055	B8555	
<b>86-98 F-350 4WD with Straight Axle</b>						
0-2"	Triple Front	TS450	4	H7012	B8512	
3-4"	Triple Front	TS450	4	H7058	B8558	
5-6"	Triple Front	TS450	4	H7041	B8541	
<b>80-85 F-350 4WD - IFS</b>						
0-2"	Triple Front	TS450	4	H7012	B8512	
3-6"	Triple Front	TS450	4	H7023	B8523	
<b>83-97 Ranger &amp; Bronco II 4WD, 2WD, 94-97 Mazda B4000 4WD, 2WD</b>						
0-2"	Dual Front	DS220	2	H7052	B8552	
3-4"	Dual Front	DS220	2	H7054	B8554	
5-8"	Dual Front	DS220	2	H7055	B8555	
<b>90-94 Explorer 4WD, 2WD, 90-94 Mazda Navajo 4WD, 2WD</b>						
0-2"	Dual Front	DS220	2	H7052	B8552	
3-4"	Dual Front	DS220	2	H7054	B8554	
5-8"	Dual Front	DS220	2	H7055	B8555	



# REAR MULTIPLE SHOCK APPLICATION GUIDE

# SHOCK SPECIFICATIONS GUIDE

LIFT	TYPE	PART #	QTY.	HYDRO	BLACK MAX	NOTES
NOTES: ALL SHOCKS MUST BE ORDERED SEPARATELY.						
<b>CHEVROLET / GMC</b>						
<b>73-87 1500 Pickup 4WD</b>						
0-1.5"	Dual Rear	DS440	2	H7043	B8543	
2-4"	Dual Rear	DS440	2	H7053	B8553	
4.5-8"	Dual Rear	DS440	2	H7073	B8573	
<b>73-87 2500 Pickup 4WD</b>						
0-1.5"	Dual Rear	DS445	2	H7043	B8543	
2-4"	Dual Rear	DS445	2	H7053	B8553	
4.5-8"	Dual Rear	DS445	2	H7073	B8573	
<b>77-87 3500 Pickup 4WD</b>						
0-1.5"	Dual Rear	DS445	2	H7053	B8553	
2-4"	Dual Rear	DS445	2	H7073	B8573	
4.5-10"	Dual Rear	DS445	2	H7078	B8578	
<b>67-72 1500 &amp; 3500 Pickup 4WD</b>						
0-1.5"	Dual Rear	DS442	2	H7043	B8543	
2-4"	Dual Rear	DS442	2	H7053	B8553	
4.5-8"	Dual Rear	DS442	2	H7073	B8573	
<b>73-87 Blazer, Jimmy Full-Size 4WD</b>						
0-1.5"	Dual Rear	DS440	2	H7043	B8543	
2-4"	Dual Rear	DS440	2	H7053	B8553	
4.5-8"	Dual Rear	DS440	2	H7073	B8573	
<b>67-72 Blazer, Jimmy Full-Size 4WD</b>						
0-1.5"	Dual Rear	DS442	2	H7043	B8543	
2-4"	Dual Rear	DS442	2	H7053	B8553	
4.5-8"	Dual Rear	DS442	2	H7073	B8573	
<b>73-91 Suburban 4WD - 1500</b>						
0-1.5"	Dual Rear	DS440	2	H7043	B8543	
2-4"	Dual Rear	DS440	2	H7053	B8553	
4.5-8"	Dual Rear	DS440	2	H7073	B8573	
<b>73-91 Suburban 4WD - 3500</b>						
0-1.5"	Dual Rear	DS445	2	H7043	B8543	
2-4"	Dual Rear	DS445	2	H7053	B8553	
4.5-8"	Dual Rear	DS445	2	H7073	B8573	
<b>67-72 Suburban 4WD</b>						
0-1.5"	Dual Rear	DS442	2	H7043	B8543	
2-4"	Dual Rear	DS442	2	H7053	B8553	
4.5-8"	Dual Rear	DS442	2	H7073	B8573	
<b>DODGE</b>						
<b>69-93 1/2, 3/4 &amp; 1 Ton Pickup, 69-93 Ramcharger / Trailduster 4WD</b>						
0-3.5"	Dual Rear	DS360	2	H7060	B8560	
4-8"	Dual Rear	DS360	2	H7079	B8579	
<b>FORD</b>						
<b>80-96 F-100, F-150 4WD - Except with Dual Gas Tanks</b>						
0-1"	Dual Rear	DS360	2	H7058	B8558	
1.5-5"	Dual Rear	DS360	2	H7060	B8560	
6-9"	Dual Rear	DS360	2	H7079	B8579	
<b>70-79 F-100, F-150 4WD</b>						
0-1"	Dual Rear	DS360	2	H7023	B8523	
1.5-2"	Dual Rear	DS360	2	H7041	B8541	
3.5-4"	Dual Rear	DS360	2	H7041	B8541	
5-8"	Dual Rear	DS360	2	H7060	B8560	
<b>80-96 F-150 2WD</b>						
0-3.5"	Dual Rear	DS360	2	H7058	B8558	
4-8"	Dual Rear	DS360	2	H7060	B8560	

LIFT	TYPE	PART #	QTY.	HYDRO	BLACK MAX	NOTES
<b>80-96 Bronco 4WD, 2WD</b>						
0-3.5"	Dual Rear	DS360	2	H7058	B8558	
4-8"	Dual Rear	DS360	2	H7060	B8560	
<b>78-79 Bronco 4WD</b>						
0"	Dual Rear	DS360	2	H7012	B8512	
1-2"	Dual Rear	DS360	2	H7023	B8523	
3-5"	Dual Rear	DS360	2	H7058	B8558	
6-10"	Dual Rear	DS360	2	H7060	B8560	
<b>67-77 Bronco 4WD</b>						
0"	Dual Rear	-----	2	H7012	B8512	
1-2.5"	Dual Rear	-----	2	H7023	B8523	
3.5-5"	Dual Rear	-----	2	H7058	B8558	
5.5-10"	Dual Rear	-----	2	H7060	B8560	
<b>80-96 F-250 4WD - Except with Dual Gas Tanks</b>						
0-1"	Dual Rear	DS360	2	H7058	B8558	
1.5-5"	Dual Rear	DS360	2	H7060	B8560	
5.5-8"	Dual Rear	DS360	2	H7079	B8579	
<b>77.5-79 F-250 4WD - Except with Dual Gas Tanks</b>						
0"	Dual Rear	DS360	2	H7058	B8558	
1-3"	Dual Rear	DS360	2	H7041	B8541	
3.5-6"	Dual Rear	DS360	2	H7060	B8560	
<b>66-77 F-250 High Boy 4WD - Except with Dual Gas Tanks</b>						
0-4"	Dual Rear	DS360	2	H7041	B8541	
<b>80-96 F-250 &amp; F-350 2WD</b>						
0-3.5"	Dual Rear	DS360	2	H7058	H7058	
4-8"	Dual Rear	DS360	2	H7060	H7060	
<b>80-98 F-350 High Boy 4WD - Except with Dual Gas Tanks</b>						
0-4"	Dual Rear	DS360	2	H7060	B8560	
4.5-8"	Dual Rear	DS360	2	H7079	B8579	
<b>83-97 Ranger 4WD</b>						
0-1"	Dual Rear	DS320	2	H7058	B8558	
1.5-4"	Dual Rear	DS320	2	H7060	B8560	
4.5-8"	Dual Rear	DS320	2	H7079	B8579	
<b>83-97 Ranger 2WD</b>						
0-3.5"	Dual Rear	DS320	2	H7058	B8558	
4-8"	Dual Rear	DS320	2	H7060	B8560	
<b>83-90 Bronco II 4WD, 2WD</b>						
0-3.5"	Dual Rear	DS320	2	H7058	B8558	
4-8"	Dual Rear	DS320	2	H7060	B8560	

SHOCKS SERIES				LENGTHS		MOUNTING CODES			
HYDRO	NITRO	Black MAX	M95	EXTENDED	COLLAPSED	UPPER	LOWER	OPTION	NOTES
H7001	N8001	B8501	M9501	22.30	13.52	S1	ES25	EB1	
H7002	N8002	B8502	M9502	15.30	10.02	S1	ES113	EB4	
H7003	N8003	B8503	M9503	18.52	12.24	S1	Clevis		
H7004	N8004	B8504	M9504	18.30	11.52	S1	ES60, ES113	EB4	
-----	N8005	-----	-----	21.25	13.05	S1	ES25	EB1	
H7006	-----	B8506	M9506	16.18	10.25	S1	BP4	EB1	A2
SHOCK NOTES: A2. Slim Body - 2"									
H7007	N8007	B8507	M9507	22.71	13.93	BP12	ES25	EB1, EB1	
H7008	N8008	B8508	M9508	19.32	12.01	BP18	ES24	EB1, EB1	A2
H7009	N8009	B8509	M9509	15.21	10.55	S1	Clevis		
H7010	-----	B8510	M9510	16.14	10.15	S1	ES34	EB4	A2
SHOCK NOTES: A2. Slim Body - 2"									
H7011	N8011	B8511	M9511	19.32	12.01	EB7	ES24	EB1, EB1	A2
H7012	N8012	B8512	M9512	19.32	12.01	ES25	ES25	EB1, EB1	A2
H7013	N8013	B8513	M9513	15.30	10.02	S1	BP4	EB1	
-----	N8014	B8514	M9514	26.52	15.74	S1	S1		
H7015	N8015	B8515	M9515	18.30	11.52	S1	BP4	EB1	
H7016	N8016	B8516	M9516	22.30	13.52	S1	BP4	EB1	
H7017	N8017	B8517	M9517	27.19	16.16	ES34	ES34	EB4, EB4	
H7018	N8018	B8518	M9518	22.71	13.93	BP18	ES24	EB1, EB1	
H7019	N8019	B8519	M9519	15.30	10.02	S1	ES34, ES60	EB4	
H7020	-----	B8520	M9520	16.14	10.15	S1	BP13	EB1	A2
SHOCK NOTES: A2. Slim Body - 2"									
H7021	N8021	B8521	M9521	19.32	12.01	ES31	ES24	EB1	A2
H7022	N8022	B8522	M9522	22.30	13.52	S1	EB4		
H7023	N8023	B8523	M9523	22.71	13.93	ES25	ES25	EB1, EB1	
H7024	N8024	B8524	M9524	24.30	14.52	S1	EB4		
H7025	N8025	B8525	M9525	24.30	14.52	S1	BP4	EB1	
H7026	N8026	B8526	M9526	18.30	11.52	S1	BP13	EB1	
H7027	N8027	B8527	M9527	24.94	14.91	ES34	ES34	EB4, EB4	
H7028	N8028	B8528	M9528	24.94	14.91	BP18	ES24	EB1, EB1	A2
SHOCK NOTES: A2. Slim Body - 2"									
H7029	N8029	B8529	M9529	24.94	14.91	BP8	ES25	EB1, EB1	
H7030	N8030	B8530	M9530	26.83	15.91	ES34	ES34	EB4, EB4	A2
SHOCK NOTES: A2. Slim Body - 2"									
H7032	N8032	B8532	M9532	29.83	17.30	ES31	ES24	EB1	
H7034	N8034	B8534	M9534	29.83	17.30	BP8	ES25	EB1, EB1	
H7035	N8035	B8535	M9535	23.32	14.04	S1	ES25	EB1	
H7036	N8036	B8536	M9536	29.83	17.36	ES34	ES34	EB4, EB4	
H7037	N8037	B8537	M9537	25.44	15.06	BP12	ES25	EB1, EB1	A2
SHOCK NOTES: A2. Slim Body - 2"									
H7038	N8038	B8538	M9538	29.83	17.30	ES27	ES34	EB1, EB4	
H7040	N8040	B8540	-----	18.18	11.26	S1	ES37		A1
SHOCK NOTES: A1. Slim Body - 1.86"									
H7041	N8041	B8541	M9541	26.33	15.55	ES25	ES25	EB1, EB1	
H7042	N8042	B8542	M9542	22.71	13.93	ES82	ES24	EB1, EB1	
H7043	N8043	B8543	M9543	24.94	14.91	EB7	ES34	EB1, EB4	
H7044	N8044	B8544	M9544	24.94	14.91	ES82	ES24	EB1, EB1	
H7045	N8045	B8545	M9545	24.30	14.52	S1	ES22		
H7047	N8047	B8547	M9547	22.71	13.93	ES34	ES34	EB4, EB4	
H7048	N8048	B8548	M9548	22.30	13.52	S1	ES22		
H7049	N8049	B8549	M9549	28.80	16.27	S1	BP4	EB1	
H7051	N8051	B8551	M9551	22.70	13.93	ES31	ES24	EB1	
H7052	N8052	B8552	M9552	15.30	10.02	S1	ES25	EB1	
H7053	N8053	B8553	M9553	27.19	16.16	EB7	ES34	EB1, EB4	
H7054	N8054	B8554	M9554	18.30	11.52	S1	ES25	EB1	
H7055	N8055	B8555	M9555	22.30	13.52	S1	ES25	EB1	
H7056	N8056	B8556	M9556	24.30	14.52	S1	ES25	EB1	
H7057	N8057	B8557	M9557	26.30	15.52	S1	ES25	EB1	A2
SHOCK NOTES: A2. Slim Body - 2"									
H7058	N8058	B8558	M9558	24.94	14.91	ES25	ES25	EB1, EB1	
H7059	N8059	B8559	M9559	27.80	16.62	S1	ES25	EB1	
H7060	N8060	B8560	M9560	29.83	17.30	ES25	ES25	EB1, EB1	

# SHOCK SPECIFICATIONS GUIDE

SHOCKS SERIES				LENGTHS		MOUNTING CODES			
HYDRO	NITRO	Black MAX	M95	EXTENDED	COLLAPSED	UPPER	LOWER	OPTION	NOTES
H7061	N8061	B8561	M9561	29.80	17.27	S1	ES25	EB1	
H7062	N8062	B8562		25.75	15.44	S38	ES25	EB1	
H7063	N8063	B8563	M9563	27.33	16.05	BP18	ES24	EB1, EB1	A2
SHOCK NOTES: A2. Slim Body - 2"									
	N8064			31.5	18.25	ES34	ES34	EB4, EB4	
H7065	N8065	B8565	M9565	24.30	14.52	S1	ES25	EB1	
H7066	N8066	B8566	M9566	27.00	16.50	S38	ES25	EB1	
H7067	N8067	B8567	M9567	26.83	15.91	BP12	ES25	EB1, EB1	A2
SHOCK NOTES: A2. Slim Body - 2"									
H7068	N8068	B8568	M9568	34.22	20.19	ES27	ES34	EB4	
H7070	N8070	B8570	M9571	28.79	16.70	ES34	ES34	EB4, EB4	A2
SHOCK NOTES: A2. Slim Body - 2"									
H7071	N8071	B8571	M9571	26.33	15.55	ES31	ES24	EB1	
H7072	N8072	B8572	M9572	26.33	15.55	BP8	ES34	EB1, EB1	
H7073	N8073	B8573	M9573	29.83	17.30	EB7	ES34	EB1, EB4	
H7074	N8074	B8574	M9574	22.30	13.52	S38	ES60	EB4	A2
SHOCK NOTES: A2. Slim Body - 2"									
H7075	N8075	B8575	M9575	26.31	15.39	S1	ES25	EB1	
H7077	N8077	B8577	M9577	34.22	20.19	BP8	ES25	EB1, EB1	
H7078	N8078	B8578	M9578	34.22	20.19	EB7	ES34	EB1, EB4	
H7079	N8079	B8579	M9579	34.22	20.19	ES25	ES25	EB1, EB1	
H7080	-----	-----	-----	13.95	9.68	EB7	ES24	EB1, EB1	
H7081	N8081	B8581	M9581	19.32	12.01	ES33	ES82	EB1	A2
H7082	N8082	B8582	M9582	19.32	12.01	ES82	ES82	EB1, EB1	A2
H7083	N8083	B8583	M9583	27.33	16.05	BP8	ES34	EB1, EB4	A2
SHOCK NOTES: A2. Slim Body - 2"									
H7084	N8084	B8584	M9584	24.94	14.91	BP8	ES34	EB1, EB4	
H7085	N8085	B8585	M9585	22.71	13.93	ES33	ES82	EB1	
H7086	N8086	B8586	M9586	29.83	17.30	BP8	ES34	EB1, EB4	
H7087	N8087	B8587	M9587	28.71	16.79	BP12	ES25	EB1, EB1	A2
SHOCK NOTES: A2. Slim Body - 2"									
H7088	N8088	B8588	M9558	24.94	14.91	ES25	ES25	EB1, EB1	A2
SHOCK NOTES: A2. Slim Body - 2"									
H7090	N8090	B8590	M9590	34.22	20.19	ES34	ES34	EB4, EB4	
H7091	N8091	B8591	M9591	22.65	13.87	S38	ES34	EB4	
H7092	N8092	B8592	M9592	24.65	14.87	S38	ES34	EB4	
H7093	N8093	B8593	M9593	26.65	15.87	S38	ES34	EB4	
H7094	N8094	B8594	M9594	28.76	16.98	S38	ES34	EB4	
	N8095			24.28	15.85				
H7096	N8096	B8596	M9596	21.50	13.68	S1	Clevis		
H7097	N8097	B8597	M9597	23.32	13.92	S1	ES25	EB1	A2
SHOCK NOTES: A2. Slim Body - 2"									
H7098	N8098	B8598	M9598	24.75	15.84	S59	ES36		
H7099	N8099	B8599	M9599	35.375	21.625	ES25	ES25	EB1, EB1	

STEERING STABILIZER SERIES			LENGTHS		MOUNTING CODES			
WHITE	BLACK	SILVER	EXTENDED	COLLAPSED	UPPER	LOWER	OPTION	NOTES
7000	8000	9000	24.21	14.68	EB1	EB1		
7202	8202	9202	20.67	12.54	EB1	EB1		A1
7263		9263	27.63	16.27	EB22	EB22		A1
7400	8400	9400	19.33	12.05	EB1	EB1		
7500	8500	9500	17.00	10.64	S1	EB1		A1
7800	8800	9800	21.88	12.85	S1	S1		
7900	8900	9900	20.27	12.00	S1	S1		

SHOCK NOTES: A1. Slim Body - 1.86"

## SHOCK & STABILIZER BOOTS

Color	EACH	Color	EACH	Color	EACH
Blue	B10B	Hunter Green	B10HG	Red	B10R
Clear	B10CL	Black	B10K	Teal	B10TL
Hot Green	B10FG	Light Blue	B10LB	White	B10WH
Hot Pink	B10FP	Purple	B10PR	Yellow	B10Y
Orange	B10OG			Gray	B10GY

# SHOCK SPECIFICATIONS GUIDE

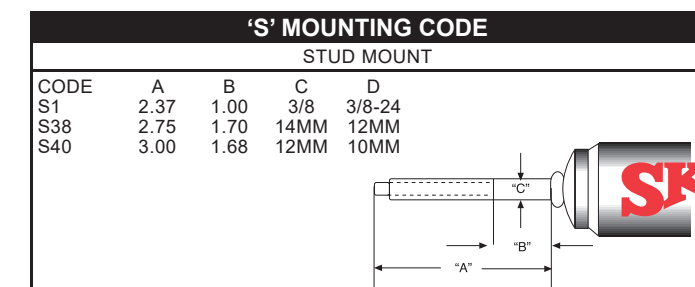
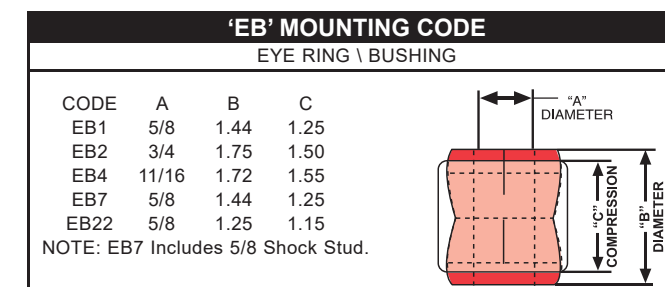
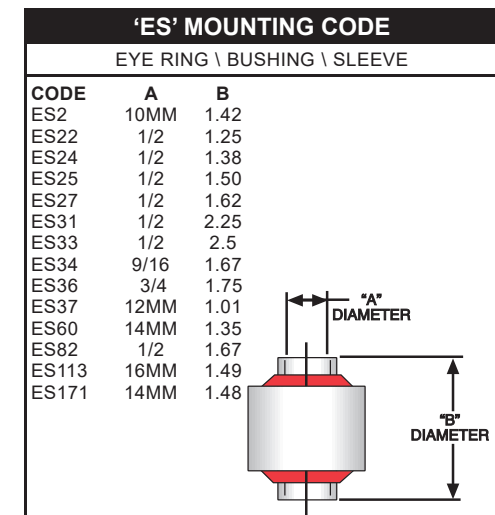
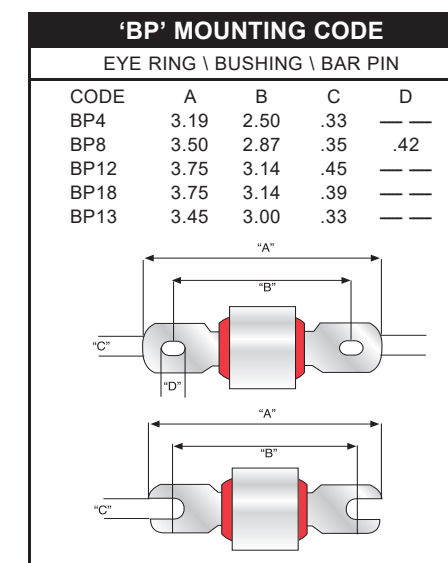
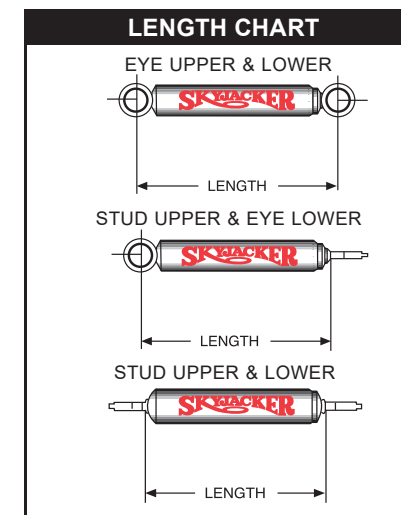

To order replacement hardware, please use mounting code part numbers listed under appropriate shock in Shock Specifications Guide.

For example:

ES25 = (1) Hourglass 5/8" Bushing + (1) Sleeve for (1) Shock End

BP4 = (1) Hourglass 5/8" Bushing + (1) Bar Pin for (1) Shock End

Note: All mounting code hardware contains (1) bushing.

## SHOCK & STABILIZER BOOTS

Color	EACH	Color	EACH	Color	EACH
Blue	B10B	Hunter Green	B10HG	Red	B10R
Clear	B10CL	Black	B10K	Teal	B10TL
Hot Green	B10FG	Light Blue	B10LB	White	B10WH
Hot Pink	B10FP	Purple	B10PR	Yellow	B10Y
Orange	B10OG			Gray	B10GY

# STEERING STABILIZERS

OEM REPLACEMENT, SINGLE & DUAL KITS												
	HEAVY DUTY OEM			SINGLE STABILIZER			DUAL STABILIZER			Single Cylinder used in kit without hardware		
	White	Black	Silver	White	Black	Silver	White	Black	Silver	White	Black	Silver
KIT NOTES: (S1). Slim Body - 1.86" (I). In-Line Mounting. (P). Parallel Mounting.												
<b>CADILLAC</b>												
<b>00-06 1500 Cadillac Escalade, EXT, ESV 4WD</b>												
00-06 1500 Cadillac Escalade, EXT, ESV 4WD with Skyjacker® 3" Lift				7196	8196	9196	7296	8296	9296	7500	8500	9500
<b>CHEVROLET / GMC</b>												
<b>02-06 1500 Avalanche 4WD</b>												
02-06 Avalanche 1500 4WD				7196	8196	9196				7500	8500	9500
02-06 Avalanche 1500 4WD with Skyjacker® 3" or 6" Lift							7296	8296	9296	7500	8500	9500
<b>00-06 1500 Tahoe / Yukon 4WD</b>												
00-06 1500 Tahoe / Yukon 4WD with Skyjacker® 3" or 6" Lift				7196	8196	9196	7296	8296	9296	7500	8500	9500
<b>02-06 1500 Denali, Denali XL 4WD</b>												
02-06 1500 Denali, Denali XL 4WD				7196	8196	9196				7500	8500	9500
02-06 1500 Denali, Denali XL 4WD with Skyjacker® 3" Lift							7296	8296	9296	7500	8500	9500
<b>02-06 2500 Avalanche 4WD</b>												
02-06 Avalanche 2500 4WD	7098	8098	9098							7202 (S1)	8202 (S1)	9202 (S1)
02-06 Avalanche 2500 4WD with Skyjacker® 6" Lift							7298	8298	9298	7500	8500	9500
<b>00-06 2500 Tahoe / Yukon 4WD</b>												
00-06 2500 Tahoe / Yukon 4WD	7098	8098	9098							7202 (S1)	8202 (S1)	9202 (S1)
00-06 2500 Tahoe / Yukon 4WD with Skyjacker® 6" Lift							7298	8298	9298	7500	8500	9500
<b>11-18 2500HD / 3500HD Pickup 4WD</b>												
11-18 2500HD / 3500HD Pickup 4WD	7011 (B)	8011 (B)	9011 (B)							7000	8000	9000
11-18 2500HD / 3500HD Pickup 4WD with 4" or More Lift							7211 (B)	8211 (B)	9211 (B)	7202 (S1)	8202 (S1)	9202 (S1)
<b>01-10 2500HD / 3500HD Pickup 4WD</b>												
01-10 2500HD / 3500HD Pickup 4WD	7098	8098	9098							7202 (S1)	8202 (S1)	9202 (S1)
01-10 2500HD / 3500HD Pickup 4WD with Skyjacker® 6" Lift							7298	8298	9298	7500	8500	9500
<b>02-10 Hummer H2 4WD</b>												
02-10 Hummer H2 4WD	7098	8098	9098							7202 (S1)	8202 (S1)	9202 (S1)
02-10 Hummer H2 4WD with Skyjacker® 6" Lift							7298	8298	9298	7500	8500	9500
<b>99-06 K1500 6-Lug Pickup 4WD</b>												
99-06 K1500 6-Lug Pickup 4WD with Skyjacker® 3" or 6" Lift				7196	8196	9196	7296	8296	9296	7500	8500	9500
<b>88-98 1500 &amp; 2500 6-Lug Pickup 4WD</b>												
88-98 1500 & 2500 6-Lug Pickup 4WD with 0-2.5" Lift				7122	8122	9122				7800	8800	9800
<b>67-87 1500 &amp; 2500 Pickup 4WD</b>												
67-87 1500 & 2500 Pickup 4WD	7055	8055	9055				7220 (I)	8220 (I)	9220 (I)	7000	8000	9000
77-87 13500 Pickup 4WD	7055	8055	9055				7255 (P)	8255 (P)	9255 (P)	7000	8000	9000
77-87 3500 Pickup 4WD*	7055	8055	9055				7255 (P)	8255 (P)	9255 (P)	7000	8000	9000
										7800	8800	9800
*Check Stabilizer Body to Confirm Replacement Cylinder 4-Digit Number.												
<b>92-98 Blazer / Tahoe, Jimmy / Yukon 4WD</b>												
92-98 Blazer / Tahoe, Jimmy / Yukon 4WD with 0-2.5" Lift				7122	8122	9122				7800	8800	9800
<b>67-91 Blazer, Jimmy 4WD, 2WD</b>												
67-91 Blazer, Jimmy 4WD	7055	8055	9055				7220 (I)	8220 (I)	9220 (I)	7000	8000	9000

# STEERING STABILIZERS

OEM REPLACEMENT, SINGLE & DUAL KITS												
	HEAVY DUTY OEM			SINGLE STABILIZER			DUAL STABILIZER			Single Cylinder used in kit without hardware		
	White	Black	Silver	White	Black	Silver	White	Black	Silver	White	Black	Silver
<b>00-06 2500 Suburban 4WD</b>												
00-06 2500 Tahoe / Yukon 4WD	7098	8098	9098							7202 (S1)	8202 (S1)	9202 (S1)
00-06 2500 Tahoe / Yukon 4WD with Skyjacker® 3" or 6" Lift							7298	8298	9298	7500	8500	9500
<b>00-06 1500 Suburban 4WD</b>												
00-06 Suburban 1500 4WD				7196	8196	9196				7500	8500	9500
00-06 Suburban 1500 4WD with Skyjacker® 3" or 6" Lift							7296	8296	9296	7500	8500	9500
<b>92-98 Suburban 4WD, 6-Lug</b>												
92-98 Suburban 4WD, 6-Lug with 0-2.5" Lift							7122	8122	9122			7800
										8800	9800	
<b>67-91 Suburban 4WD</b>												
67-91 Suburban 1500 & 2500 4WD	7055	8055	9055							7220 (I)	8220 (I)	9220 (I)
										7000	8000	9000
<b>57-73 1500, 2500 &amp; 3500 Pickup 4WD</b>												
58-72 1500, 2500 & 3500 Pickup 4WD - Up to 3" Diameter Axle				7110	8110	9110				7800	8800	9800
57-73 Dana 60 Axles 4WD - Up to 3" O.D.				7110	8110	9110				7800	8800	9800
<b>DANA AXLES</b>												
<b>All Dana Axles 2.75-3.5" Axle Tubes</b>												
All Dana 30 Axles - Up to 2.75" Axle Tube				7100	8100	9100				7900	8900	9900
All Dana 44 Axles - Up to 3" Axle Tube				7110	8110	9110				7800	8800	9800
All Dana 60 Axles - Up to 3" Diameter				7110	8110	9110				7800	8800	9800
<b>DODGE</b>												
<b>03-18 2500 &amp; 3500 Ram 4WD</b>												
14-18 2500 Ram 4WD - Must have at least 4" lift for Dual Stabilizers	7014	8014	9014							7214	8214	9214
										7000	8000	9000
13-18 3500 Ram 4WD - Must have at least 4" lift for Dual Stabilizers	7014	8014	9014							7214	8214	9214
										7000	8000	9000
09-13 2500 & 09-12 3500 Ram 4WD										7239	8239	9239
										7000	8000	9000
03-08 2500 & 3500 Ram 4WD	7013	8013	9013							7213 (I)	8213 (I)	9213 (I)
										7000	8000	9000
03-08 2500 & 3500 Ram 4WD (Update Kit)										7213UP	8213UP	9213UP
NOTES: Part # 7213UP is to be Used when Customer has Replaced their 03-08 Dodge OEM Drag Link with the New OEM Heavy Duty Dodge Drag Link.												
<b>98-02 1/2, 3/4 &amp; 1 Ton Ram 4WD</b>												
98-01 1/2, 98-02 3/4 & 1 Ton Ram 4WD	7007	8007	9007							7218 (I)	8218 (I)	9218 (I)
										7000	8000	9000
98-01 1/2, 98-02 3/4 & 1 Ton Ram 4WD with Drop Pitman Arm	7017	8017	9017							7218 (I)	8218 (I)	9218 (I)
										7000	8000	9000
98-02 3/4 & 1 Ton Ram 4wd with 3 3/4 Axle Tube										7270	8270	9270
										7000	8000	9000
<b>94-97 1/2, 3/4 &amp; 1 Ton Ram 4WD</b>												
94-97 1/2, 3/4 & 1 Ton Ram 4WD	7007	8007	9007							7217 (P)	8217 (P)	9217 (P)
										7000	8000	9000
94-97 1/2, 3/4 & 1 Ton Ram 4WD with Drop Pitman Arm	7017	8017	9017							7217 (P)	8217 (P)	9217 (P)
										7000	8000	9000
<b>60-93 1/2, 3/4 &amp; 1 Ton Pickup &amp; Ramcharger 4WD</b>												
60-93 1/2, 3/4 & 1 Ton Pickup & Ramcharger 4WD							7110	8110	9110	7220 (I)	8220 (I)	9220 (I)
										7000	8000	9000
<b>45-93 Power Wagon 4WD</b>												
45-93 Power Wagon 4WD with Larger than 3" Front Axle							7110	8110	9110			7800
										8800	9800	
<b>86-89 Raider 4WD</b>												
86-89 Raider 4WD							7100	8100	9100			7900
										8900	9900	
<b>54-71 1/2, 3/4 &amp; 1 Ton Pickup 2WD</b>												
54-71 1/2, 3/4 & 1 Ton Pickup 2WD with Straight Front Axle							7100	8100	9100			7900
										8900	9900	
KIT NOTES: (S1). Slim Body - 1.86" (I). In-Line Mounting. (P). Parallel Mounting. (B). Boot Not Included Due to Clearance Issues.												

# STEERING STABILIZERS

OEM REPLACEMENT, SINGLE & DUAL KITS												
	HEAVY DUTY OEM			SINGLE STABILIZER			DUAL STABILIZER			Single Cylinder used in kit without hardware		
	White	Black	Silver	White	Black	Silver	White	Black	Silver	White	Black	Silver
<b>FORD</b>												
<b>70-03 F-100, F-150 Pickup 4WD</b>												
97-03 F-150 Pickup 4WD with Skyjacker® 6" Lift							7297	8297	9297	7500	8500	9500
80-96 F-150 Pickup 4WD				7140	8140	9140	7240 (P)	8240 (P)	9240 (P)	7800	8800	9800
70-79 F-100, F-150 Pickup 4WD	7030	8030	9030							7800	8800	9800
71-76 F-150 Pickup 4WD with No OEM Location				7110	8110	9110	7240 (P)	8240 (P)	9240 (P)	7800	8800	9800
70-77 F-150 Pickup 4WD with OEM Location							7210	8210	9210	7800	8800	9800
77-79 F-100, F-150 Pickup 4WD							7210 (P)	8210 (P)	9210 (P)	7800	8800	9800
<b>50-96 F-100, F-150 Pickup 2WD</b>												
80-96 F-100, F-150 Pickup 2WD				7140	8140	9140	7240 (P)	8240 (P)	9240 (P)	7800	8800	9800
50-64 1/2 Ton Pickup 2WD with Straight Axle				7100	8100	9100				7900	8900	9900
<b>59-18 F-250 &amp; F-350 Pickup 4WD</b>												
11-18 F-250 & F-350 Super Duty 4WD							7254 (I)A3	8254 (I)A3	9254 (I)A3	7000	8000	9000
08-16 Ford Super Duty 4WD F250, F350, F450, F550	7054	8054	9054									
05-10 F-250 & F-350 Super Duty 4WD with 4" Lift				7154	8154	9154	7254 (I)	8254 (I)	9254 (I)	7000	8000	9000
05-10 F-250 & F-350 Super Duty 4WD with 6" Lift				7156	8156	9156	7254 (I)	8254 (I)	9254 (I)	7000	8000	9000
99-04 F-250 & F-350 Super Duty 4WD	7099	8099	9099	7199	8199	9199	7299 (I)	8299 (I)	9299 (I)	7000	8000	9000
80-98 F-250 & F-350 IFS Pickup 4WD				7140 A3	8140 A3	9140 A3	7240 (P)A3	8240 (P)A3	9240 (P)A3	7800	8800	9800
80-85 F-350 IFS Pickup 4WD				7140 A3	8140 A3	9140 A3	7240 (P)A3	8240 (P)A3	9240 (P)A3	7800	8800	9800
86-98 F-350 Straight Axle Pickup 4WD				7110	8110	9110	7240 (P)A3	8240 (P)A3	9240 (P)A3	7800	8800	9800
59-79 F-250 & F-350 Pickup 4WD (Except with Slave Cylinder PS)				7110	8110	9110	7220 (I)A3	8220 (I)A3	9220 (I)A3	7000	8000	9000
KIT NOTE: A3. Must have a Minimum of 3" Lift.												
<b>00-05 Excursion 4WD</b>												
00-05 Excursion 4WD	7099	8099	9099	7199	8199	9199	7299 (I)	8299 (I)	9299 (I)	7000	8000	9000
<b>83-97 Ranger 4WD, 2WD</b>												
83-97 Ranger 4WD, 2WD				7150	8150	9150	7250 (P)	8250 (P)	9250 (P)	7900	8900	9900
<b>83-90 Bronco II 4WD</b>												
83-90 Bronco II 4WD				7150	8150	9150	7250 (P)	8250 (P)	9250 (P)	7900	8900	9900
<b>83-90 Bronco II 2WD</b>												
83-90 Bronco II 2WD				7140	8140	9140	7240 (P)	8240 (P)	9240 (P)	7800	8800	9800
<b>90-94 Explorer 4WD</b>												
90-94 Explorer 4WD				7150	8150	9150	7250 (P)	8250 (P)	9250 (P)	7900	8900	9900
<b>90-94 Explorer 2WD</b>												
90-94 Explorer 2WD				7140	8140	9140	7240 (P)	8240 (P)	9240 (P)	7800	8800	9800
<b>66-96 Bronco 4WD</b>												
80-96 Bronco 4WD				7140	8140	9140	7240 (P)	8240 (P)	9240 (P)	7800	8800	9800
78-79 Bronco 4WD	7030	8030	9030				7210	8210	9210	7800	8800	9800
70-77 Bronco 4WD	7030	8030	9030							7800	8800	9800
66-75 Bronco 4WD				7110	8110	9110				7800	8800	9800
<b>INTERNATIONAL</b>												
<b>61-82 Scout 4WD, 2WD</b>												
69-82 Scout II, Terra & Traveler 4WD, 2WD				7110	8110	9110				7800	8800	9800
67-75 Scout 4, 6 & 8 Cylinder, 4WD, 2WD Includes Scout II				7110	8110	9110				7800	8800	9800
61-68 Scout 80 & 800 Series 4WD, 2WD (Except V8)				7100	8100	9100				7900	8900	9900

# STEERING STABILIZERS

OEM REPLACEMENT, SINGLE & DUAL KITS												
	HEAVY DUTY OEM			SINGLE STABILIZER			DUAL STABILIZER			Single Cylinder used in kit without hardware		
	White	Black	Silver	White	Black	Silver	White	Black	Silver	White	Black	Silver
<b>60-75 Pickup, Travelall &amp; Metros 4WD, 2WD</b>												
60-75 1/2 & 3/4 Ton Pickup & Travelall 4WD, 2WD with Straight Axle										7110	8110	9110
60-75 1/2 & 3/4 Ton Metros 4WD with Straight Axle										7110	8110	9110
60-74 1/2 & 3/4 Ton Metros 2WD with Straight Axle										7100	8100	9100
<b>MITSUBISHI</b>												
<b>86-90 Montero 4WD</b>												
86-88 Montero Raider 4WD										7100	8100	9100
<b>JEEP</b>												
<b>41-18 JL, JK, TJ, YJ, CJ 4WD</b>												
2018 Wrangler JL 4WD	7008	8008	9008							7208 (B)	8208 (B)	9208 (B)
07-18 Wrangler JK, Rubicon 4WD	7003	8003	9003							7203 (B)	8203 (B)	9203 (B)
97-06 Wrangler TJ, Rubicon, Unlimited, Unlimited Rubicon 4WD	7009	8009	9009	7119	8119	9119	7219	8219	9219	7400	8400	9400
with Skyjacker Adjustable Track Bar & Stabilizer Assembly										7112	8112	9112
*Check Stabilizer Body to Confirm Replacement Cylinder 4-Digit Number.												
87-96 Wrangler YJ 4WD*	7009	8009	9009	7109	8109	9109	7200 (P)	8200 (P)	9200 (P)	7400	8400	9400
*Check Stabilizer Body to Confirm Replacement Cylinder 4-Digit Number.												
76-86 C.J.'s 4WD*	7001	8001	9001	7100	8100	9100	7200 (P)	8200 (P)	9200 (P)	7500	8500	9500
*Check Stabilizer Body to Confirm Replacement Cylinder 4-Digit Number.												
41-86 All C.J.'s (Except C.J.'s with Slave Cylinder Power Steering)										7100	8100	9100
<b>47-01 Jeep SUVs 4WD, 2WD</b>												
84-01 Cherokee XJ Midsize 4WD, 2WD	7009	8009	9009									7400
74-83 Cherokee Full-Size 4WD	7005	8005	9005									7000
93-98 Grand Cherokee ZJ 4WD, 2WD	7009	8009	9009									7400
84-91 Grand Wagoneer Full-Size 4WD	7005	8005	9005									7000
84-90 Wagoneer XJ 4WD, 2WD	7009	8009	9009									7400
74-83 Wagoneer Full-Size 4WD	7005	8005	9005									7000
66-73 Jeepster / Commando 4WD										7100	8100	9100
86-92 Comanche Pickup 4WD, 2WD	7009	8009	9009									7400
74-88 J10, J20 Pickup 4WD	7005	8005	9005									7000
63-73 Gladiator Series										7110	8110	9110
47-63 Utility Series & Wagons										7110	8110	9110
<b>PLYMOUTH</b>												
<b>54-93 B100, B200, B300, Trailduster 4WD</b>												
74-93 Trailduster 4WD										7110	8110	9110
54-71 B100, B200, B300 4WD with Straight I-Beam Axle										7100	8100	9100
<b>TOYOTA</b>												
<b>61-95 Pickup &amp; SUVs 4WD</b>												
86-95 Pickup & 4Runner 4WD										7186	8186	9186
79-85 Pickup & 4Runner 4WD	7070	8070	9070									7900
84-85 Pickup & 4Runner 4WD										7175	8175	9175
79-83 Pickup 4WD										7275 (P)	8275 (P)	9275 (P)
61-82 LandCruiser 4WD										7160	8160	9160
<b>SUZUKI</b>												
<b>79-91 Samurai, Santana, LJ10, SJ10, LJ413 4WD</b>												
79-91 Samurai, Santana, LJ10, SJ10, LJ413 4WD										7100	8100	9100
KIT NOTES: (S1). Slim Body - 1.86" (I). In-Line Mounting. (P). Parallel Mounting. (B). Boot Not Included Due to Clearance Issues.												

# ACCESSORIES

## CHEVROLET / GMC - ACCESSORIES

ALIGNMENT SHIMS			
Description	DEGREE	Part #	
<b>88-98 1500, 2500 Pickups 4WD</b>			
Eccentric Cam Bolt Kit	0-2	1088H	
<b>92-98 Blazer, Tahoe, Jimmy, Yukon, Suburban 4WD</b>			
Eccentric Cam Bolt Kit	0-2	1088H	
DRAG LINK & TIE ROD ASSEMBLIES			
Description	LIFT	Part #	NOTES
<b>67-87 1500, 2500 Pickup 4WD (4" Offset)</b>			
Offset & Adjustable Drag Link	4-6"	GMDL4	
<b>67-87 1 Ton Pickup 4WD</b>			
Offset & Adjustable Drag Link	4-6"	GMDL4	
<b>67-91 Blazer, Jimmy, Suburban 4WD</b>			
Offset & Adjustable Drag Link	4-6"	GMDL4	
Replacement End for GMDL4		GMDL4-1	
DRIVE TRAIN			
Description	LIFT	Part #	NOTES
<b>10-18 Chevrolet / GMC 1500</b>			
Front Drive Shaft - 6" Lift		GM10146DS	
			
<b>11-18 Chevrolet / GMC 2500HD / 3500HD</b>			
Carrier Bearing Lowering Kit - 2" Drop		CBL2500	
FRAME SHACKLE BUSHING KITS			
Description	FRONT	REAR	NOTES
<b>Original Equipment</b>			
<b>69-87 1500, 2500 &amp; 3500 Pickups 4WD with 52" Rear Springs</b>			
		SE13C	
<b>71-87 1500, 2500 &amp; 3500 Pickups 4WD</b>			
	SE12C		
<b>67-87 Blazer, Jimmy, Suburban 4WD</b>			
	SE12C	SE13C	Z1
<b>69-91 Blazer, Jimmy, Suburban 4WD with 52" Rear Springs</b>			
	SE12C	SE13C	Z1
KIT NOTES: Z1. Front Upper Shackle Mounts will NOT Fit 67-70 Models.			
POLY BUMP STOPS - PAIR			
LIFT	FRONT	REAR	NOTES
<b>67-87 1500, 2500 &amp; 3500 Pickups 4WD</b>			
4.5"	BP45	BP45	
<b>67-87 Blazer, Jimmy, Suburban 4WD</b>			
4.5"	BP45	BP45	
SHOCK RELOCATION BRACKETS			
Description	LIFT	Part #	
<b>99-06 1500 GM Models with Autoride</b>			
Front & Rear Brackets (Rear Coil Vehicles)	3"	C93AR	
SKID PLATES, OIL PANS & SHIFTER BRACKET			
Description	LIFT	Part #	NOTES
<b>11-16 GM 2500HD / 3500HD 4WD DEF / Urea Tank Skid Plate</b>			
DEF / Urea Tank Skid Plate		DEFG114SP	
SPRING EYE BUSHING KITS			
Description	FRONT	REAR	NOTES
<b>Original Equipment</b>			
<b>69-87 1500 &amp; 2500 Pickups 4WD with 52" Rear Springs</b>			
		SE15C	

<b>88-91 Blazer, Jimmy, Suburban 4WD</b>	SE18C		
<b>69-91 Blazer, Jimmy, Suburban 4WD with 52" Rear Springs</b>		SE15C	
<b>Skyjacker® Softride®</b>			
<b>67-87 1500 &amp; 2500 Pickups 4WD</b>	SE11C		
<b>69-87 1500 &amp; 2500 Pickups 4WD with 52" Rear Springs</b>		SE15C	
<b>88-91 Blazer, Jimmy, Suburban 4WD</b>	SE17C		
<b>67-87 Blazer, Jimmy, Suburban 4WD</b>	SE11C		
<b>69-91 Blazer, Jimmy, Suburban 4WD with 52" Rear Springs</b>		SE15C	
SWAY BAR BUSHING KITS			
Description	FRONT	REAR	
<b>80-87 1500, 2500 &amp; 3500 Pickup 4WD</b>			
	CSB148		
<b>88-91 Blazer, Jimmy, Suburban 4WD</b>			
	CSB148		
<b>73-79 1500, 2500 &amp; 3500 Pickup 4WD Blazer, Jimmy, Suburban 4WD</b>			
	CSB149		
SWAY BAR EXTENDED END LINKS			
End Links Include Bushings			
		LOCATION	
Description	LIFT	FRONT	REAR
<b>07-18 GM 1500 4WD</b>			
	4"	C766SBL	
	6"	C966SBL	
<b>01-10 GM 2500HD / 3500HD 4WD</b>			
	3"	C766SBL	
	6"	C966SBL	
<b>99-06 &amp; 07 Classic GM 1500 4WD</b>			
	3-4"	C766SBL	
	6"	C966SBL	
<b>00-06 Avalanche / Tahoe GM 1500 4WD</b>			
	3"	C766SBL	
	6"	C966SBL	
<b>02-10 Hummer H2 4WD</b>			
	6"	C966SBL	
SWAY BAR LOWERING KITS			
ALL 1500, 2500 & 3500 Pickup, Blazer, Jimmy, Suburban 4WD with Front Leaf Springs			
	4"	SBL20	
	6-8"	SBL40	
TRANSFER CASE LOWERING KITS			
Description	LIFT	Part #	
<b>73-87 Pickup, 73-91 Blazer, Jimmy, Yukon, Tahoe &amp; Suburban 4WD - Full-Size with Leaf Spring Front</b>			
	4-8"	TCL15	
WHEEL SPACERS			
<b>14-18 GM K1500 4WD</b>			
<b>WHEEL SPACERS, 6X5.5, 18" OEM WHEEL</b>			
		WSP655	

## DODGE - Accessories

DRAG LINK & TIE ROD ASSEMBLIES			
Description	LIFT	Part #	NOTES
<b>72-93 1/2, 3/4 &amp; 1 Ton Pickup, Ramcharger, Trailduster 4WD - Full-Size</b>			
Adjustable Drag Link	2-8"	DL10	

FRAME SHACKLE BUSHING KITS			
Description	FRONT	REAR	NOTES
<b>Original Equipment</b>			
<b>61-93 1/2, 3/4 &amp; 1 Ton Pickup, Ramcharger, Trailduster 4WD</b>			
	SE14D		
POLY BUMP STOPS - PAIR			
LIFT	FRONT	REAR	NOTES
<b>94-01 1/2, 3/4 &amp; 1 Ton Ram Pickup 4WD</b>			
6"	BP60		
ROD ENDS			
Heavy-Duty Kevlar® / Teflon® Lined Self-Lubricating Rod Ends			
Description	Part #		
Heavy-Duty - Non Teflon Lined (Right Hand Thread) Used on 94-01 Dodge Adjustable Track Bar			
	HD34X34DTB		
SPRING EYE BUSHING KITS			
Description	FRONT	REAR	NOTES
<b>Original Equipment</b>			
<b>61-93 1/2, 3/4 &amp; 1 Ton Pickup, Ramcharger, Trailduster 4WD</b>			
	SE12D		
<b>Skyjacker® Softride®</b>			
<b>61-93 1/2, 3/4 &amp; 1 Ton Pickup, Ramcharger, Trailduster 4WD</b>			
	SE12D		
<b>72-93 3/4, 1 Ton Pickups with 3/4" Main Eye Bolt</b>			
		SE17D	
SWAY BAR BUSHING KITS			
Description	FRONT	REAR	
<b>94-01 1/2, 3/4 &amp; 1 Ton Pickup 4WD</b>			
	DSB94		
SWAY BAR EXTENDED END LINKS			
End Links Include Bushings			
		LOCATION	
Description	LIFT	FRONT	REAR
<b>02-05 Dodge Ram 1500 4WD</b>			
	5-6"	SBE5069	
<b>06-15 Dodge Ram 1500 4WD</b>			
	4-6"	C966SBL	
SWAY BAR LOWERING KITS			
Description	Lift	Part #	
<b>94-01 1/2 Ton Pickup 4WD</b>			
	4-5"	SBL20	
<b>94-12 3/4 &amp; 1 Ton 4WD</b>			
	4-5"	SBL20	
<b>61-93 1/2, 3/4 &amp; 1 Ton Pickup, Ramcharger, Trailduster 4WD with Front Leaf Springs</b>			
	4"	SBL20	
	6-8"	SBL40	
TRACK BAR COMPONENTS			
Description	LIFT	Part #	NOTES
<b>94-01 Dodge 1/2, 3/4 &amp; 1 Ton Adjustable Replacement Front Track Bar Kit</b>			
	4-7"	DTBA27	
Transfer Case Re-Indexing Ring & Seal Adapter (6 Bolt Transfer Case Only)			
Description	LIFT	Part #	NOTES
<b>94-01 Ram 1/2, 3/4, 1 Ton 4WD</b>			
	7" & Above	IXR10	K19
<b>94-01 Ram 1/2, 3/4, 1 Ton 4WD</b>			
		IXR20	K19
KIT NOTES: K19. Seal Part # TCS2675 & Seal Adapter Required, Part # DTSA10 (2.57") or DTSA269 (2.69") Seal Adapter which will Only Work on Models with 6 Bolts Attaching Transmission to Transfer Case.			
			
	# DTSA10	# IXR10	
<b>02-05 Ram 1500 4WD</b>			
		IXR20K	K20, K21

# ACCESSORIES

<b>03-13 Ram 2500, 03-12 3500 4WD</b>	IXR20K	K20, K21	
KIT NOTES: K20. Designed for Custom Applications Only - Includes 2.69" Seal. K21. Seal Adapter DTSA10 may be Required on Some Models.			
FORD - Accessories			
ALIGNMENT SHIMS			
KIT NOTES: Shims Sold as Single. Order 1 Per Side.			
Description	DEGREE	Part #	
<b>09-14 F-150 4WD</b>			
Caster / Camber Alignment Shim		F900CAK	
<b>04-08 F-150 4WD</b>			
Caster / Camber Alignment Shim		F462-AK	
<b>80-96 F-150, Bronco, F-250 4WD</b>			
Caster / Camber Shim	0-2.75	1032H	
<b>87-96 F-150, Bronco, F-250 2WD</b>			
Caster / Camber Shim	0-2	1029H	
<b>82-86 F-100, F-150, Bronco, F-250 2WD</b>			
Caster / Camber Shim	0-2	1043H	
<b>80-85 F-350 4WD</b>			
Caster / Camber Shim	0-2.75	1032H	
<b>90-97 Ranger 4WD</b>			
Caster / Camber Shim	0-2	1039H	
<b>89-97 Ranger, Bronco II 2WD</b>			
Caster / Camber Shim	0-2	1029H	
<b>83-88 Ranger, Bronco II 2WD</b>			
Caster / Camber Shim	0-2	1043H	
<b>90-94 Explorer 4WD</b>			
Caster / Camber Shim	0-2	1039H	
<b>90-94 Explorer 2WD</b>			
Caster / Camber Shim	0-2	1029H	
C' BUSHING KITS - 4 PIECE ONLY			
Description	LIFT	DEGREE	Part #
<b>66-79 F-100, F-150 4WD</b>			
	4-5	7	CB70
<b>78-79 Bronco 4WD</b>	0-1	2	CB20
	2-3	4	CB40
	4-5	7	CB70
<b>66-77 Bronco 4WD</b>	0-1	2	CB20
	2-3	4	CB40
	4-5	7	CB70
C' BUSHING KITS (COMPLETE) - 14 PIECE			
C' Bushings, Radius Arm & Track Bar Bushings			
<b>66-76 F100, F150 4WD &amp; 78-79 F100, F150 4WD</b>	0-1"	2	CB200
	2-3"	4	CB400
	4-5"	7	CB700
<b>77 F-100, F-150 4WD</b>	0-1"	2	CB277
	2-3"	4	CB477
	4-5"	7	CB777
<b>78-79 Bronco 4WD</b>	0-1"	2	CB200
	2-3"	4	CB400
	4-5"	7	CB700
<b>76-77 Bronco 4WD</b>	2-3"	4	CB477
	4-5"	7	CB777
	0-1"	2	CB200
<b>66-75 Bronco 4WD</b>	2-3"	4	CB400
	4-5"	7	CB700
	0-1"	2	CB200
TRACK ARM BUSHING KIT			
<b>66-76 F100, F150 4WD</b>			
			TAB75
<b>78-79 F100, F150 4WD</b>			
			TAB75
<b>77 F100, F150 4WD</b>			
			TAB77
<b>66-75 Bronco 4WD</b>			
			TAB75
<b>78-79 Bronco 4WD</b>			
			TAB75
<b>76-77 Bronco 4WD</b>			
			TAB77
RADIUS ARM BUSHING KIT			
<b>66-79 F100, F150 4WD</b>			
			SAB75
<b>66-77 Bronco 4WD</b>			
			SAB75
<b>78-79 Bronco 4WD</b>			
			SAB75

# ACCESSORIES

CENTER HINGE DROP BRACKETS - PAIR			
Description	LIFT	Part #	
<b>80-96 F-150, Bronco 4WD, 2WD</b>			
	4-6"	CHB54	
	8"	CHB58	
<b>80-98 F-250 IFS 4WD</b>			
	4-6"	CHB75	
<b>80-85 F-350 IFS</b>			
	4-6"	CHB75	
<b>83-97 Ranger, Bronco II 4WD</b>			
	4-6"	CHB352	
<b>83-97 Ranger, Bronco II 2WD</b>			
	4-6"	CHB324	
	4-6"	CHB326	
<b>90-94 Explorer 4WD</b>			
	4-6"	CHB352	
CENTER HINGE PIVOT BUSHINGS			
Re-Uses Existing OEM Metal Outer Shells		Part #	
<b>80-96 F-150, Bronco 4WD, 2WD</b>		CHB80	
<b>80-85 F-350 IFS 4WD</b>		CHB80	
<b>80-98 F-250 IFS 4WD</b>		CHB80	
<b>83-97 Ranger 4WD</b>		CHB80	
<b>83-90 Bronco II 4WD</b>		CHB80	
<b>90-94 Explorer 4WD</b>		CHB80	
COIL SPRING Spacers			
Description	SIZE		
<b>05-18 Ford F-250, F-350 4x4</b>			
Coil Spring Spacers - Pair	1"	F51MS	
Coil Spring Spacers - Pair	2.5"	F52MS	
DRAG LINK & TIE ROD ASSEMBLIES			
Description	LIFT	Part #	NOTES
<b>76-79 F-100, F-150 4WD</b>			
Adjustable Drag Link	0-9"	FDL70	V1
Adjustable Tie Rod	0-9"	TRA70	
KIT NOTES: V1. On 76-77 Models, Must be Used in Conjunction with a Pitman Arm for 78-79 Ford Power Steering Boxes (Such as Skyjacker® Drop Pitman Arm # FA300).			
<b>78-79 Bronco 4WD</b>			
Adjustable Drag Link	0-9"	FDL70	
Adjustable Tie Rod	0-9"	TRA70	
<b>77.5-79 F-250, F-350 4WD</b>			
Offset Adjustable Drag Link			
	3-4"	SDL250	
Offset Adjustable Drag Link + FA325 Drop Pitman Arm			
	5-6"	SDL250 + FA325	
Replacement End for SDL250			
		TRE250	
DRIVE TRAIN			
Description	LIFT	Part #	NOTES
<b>17-18 F-250, F-350, Super Duty</b>			
Front Drive Shaft - 6-8.5" Lift			
		F17685DS	
			
<b>05-16 F-250, F-350, Super Duty</b>			
Carrier Bearing Lowering Kit - 2" Drop			
		CBL206	
<b>80-04 F-250, F-350, Super Duty</b>			
Carrier Bearing Lowering Kit - 1" Drop			
		CBL3401	
Carrier Bearing Lowering Kit - 2-2.25" Drop			

				CBL214	
FRAME SHACKLE BUSHING KITS					
Description	FRONT	REAR	NOTES		
<b>ORIGINAL EQUIPMENT</b>					
<b>80-98 F-250, F-350 4WD</b>	SE85F				
RADIUS ARM DROP BRACKETS					
Description		LIFT	Part #		
REPLACEMENT DROP BRACKETS					
80-96 F-150 4WD, 2WD		4-6"	RAB54		
80-96 F-150 4WD, 2WD		8"	RAB58		
80-96 Bronco 4WD, 2WD		4-6"	RAB54		
80-96 Bronco 4WD, 2WD		8"	RAB58		
83-97 Ranger 4WD, 2WD		4-6"	RABE30		
83-97 Ranger 4WD		8"	RAB38		
83-90 Bronco II 4WD, 2WD		4-6"	RABE30		
91-94 Explorer 4WD, 2WD		4-6"	RABE30		
RELOCATING DROP BRACKETS					
<b>66-79 F-150 4WD</b>	2.75" Drop	3.5-4"	RAB27		
	4.75" Drop	5-6"	RAB47		
<b>78-79 Bronco 4WD</b>	2.75" Drop	3.5-4"	RAB27		
	4.75" Drop	5-6"	RAB47		
<b>66-77 Bronco 4WD</b>	4" Drop	5"	RAB40		
FRAME SUPPORT BAR					
<b>80-96 F-150, Bronco 4WD</b>		4-8"	FSB80		
RADIUS / STRUT ARM BUSHINGS					
Description			Part #		
2 DEGREE ADJUSTABLE CASTER					
<b>80-83 F-150 2WD</b>			SAB20		
<b>80-96 Bronco 4WD</b>			SAB20		
<b>87-02 F-250, F-350 2WD</b>			SAB20		
<b>83-88 Ranger 2WD</b>			SAB20		
<b>86-88 Bronco II 2WD</b>			SAB20		
OEM REPLACEMENT					
<b>80-96 F-150 4WD, 2WD</b>			SAB85		
<b>66-79 F-100, F-150 4WD, 2WD</b>			SAB75		
<b>80-96 Bronco 4WD</b>			SAB85		
<b>66-79 Bronco 4WD</b>			SAB75		
<b>80-96 F-250 2WD</b>			SAB85		
<b>83-97 Ranger 4WD, 2WD</b>			SAB83		
<b>83-90 Bronco II 4WD, 2WD</b>			SAB83		
<b>90-94 Explorer 4WD, 2WD</b>			SAB83		
REPLACEMENT TUBULAR RADIUS ARMS - CLASS II					
Description	LIFT	Part #			
<b>80-96 F-150, Bronco 4WD, 2WD - Stock + 15" Includes Poly Bushings</b>					
	4-6"	RA150			
<b>83-97 Ranger, Bronco II, Explorer 4WD - Stock + 15" Includes Mounting Brackets &amp; Bushings</b>					
	4-6"	RA135			
<b>83-97 Ranger, Bronco II 2WD - Stock + 15" Includes Mounting Brackets &amp; Bushings</b>					
	4-6"	RA235			
ROD ENDS					
Heavy-Duty Kevlar® / Teflon® Lined Self-Lubricating Rod Ends					
Description			Part #		
Heavy-Duty - Non Teflon Lined (Right Hand Thread)					
Used on 05-08 F-250 / 350 Adjustable 4-Link (F58484LU)					
			HDRB114X1R		
SPRING EYE BUSHING KITS					
Description	FRONT	REAR	NOTES		
<b>Softride® - For Skyjacker® Leaf Springs Only</b>					
<b>99-04 F-250, F-350 4WD</b>	SE90F				
<b>80-98 F-250, F-350 4WD</b>	SE80F	SE84R			
<b>67-79 F-250, F-350 4WD</b>	SE70F				
SPRING SPACER PLATES					
Description	LIFT	Part #			

<b>80-96 F-150, Bronco 4WD, 2WD - No More than 2 Per Coil Spring can be Used</b>					
Coil Spring Spacer Plates - Each	3/8"	HS25			
<b>83-97 Ranger 4WD, 2WD - No More than 2 Per Coil Spring can be Used</b>					
Coil Spring Spacer Plates - Each	3/8"	HS25			
<b>83-90 Bronco II 4WD - No More than 2 Per Coil Spring can be Used</b>					
Coil Spring Spacer Plates - Each	3/8"	HS25			
<b>90-94 Explorer, Mazda Navajo 4WD, 2WD - No More than 2 Per Coil Spring can be Used</b>					
Coil Spring Spacer Plates - Each	3/8"	HS25			
SWAY BAR EXTENDED END LINKS					
End Links Include Polyurethane Bushings					
Description	LIFT	FRONT	REAR		LOCATION
<b>97-03 F-150 4WD</b>					
	6"	C966SBL			
<b>77-79 F-150 4WD</b>					
	3-4"	SBE204			
	6-9"	SBE205			
<b>06-04 Dodge Ram 1500 4WD</b>					
	4-6"	C966SBL			
<b>78-79 Bronco 4WD</b>					
	3-4"	SBE204			
	6-9"	SBE205			
<b>00-05 Excursion 4WD</b>					
	3-4"	SBE407			
	5-8"	SBE408			
<b>08-16 F-250, F-350 Super Duty 4WD</b>					
	4"		SBE404		
	6"		SBE405		
	8.5"		SBE406		
<b>08-10 F-250, F-350 Super Duty 4WD</b>					
	4"	SBE5084			
	6-8"	SBE5086			
<b>05-07 F-250, F-350 Super Duty 4WD</b>					
	3-4"	SBE5954	SBE404		
	5-8"	SBE5956	SBE405		
	7-8"	SBE5956	SBE406		
<b>00-04 F-250, F-350 Super Duty 4WD</b>					
	3-4"	SBE407	SBE404		
	5-8"	SBE408	SBE405		
	7-8"	SBE408	SBE406		
<b>03/99-99 F-250, F-350 Super Duty 4WD - Built After March '99</b>					
	3-4"	SBE402	SBE404		
	5-6"	SBE403	SBE405		
	7-8"	SBE403	SBE406		
<b>99 F-250 Super Duty 4WD - Built Before March '99</b>					
	3-4"	SBE402			
	5-6"	SBE403			
	7-8"	SBE403			
<b>80-98 F-250 IFS 4WD</b>					
	3-4"	SBE302			
	5-6"	SBE303			
	2-3"		SBE304		
	3.5-5"		SBE305		
<b>86-98 F-350 4WD</b>					
	3-4"	SBE304			
	5-6"	SBE305			
<b>80-85 F-350 IFS 4WD</b>					
	3-4"	SBE302			
	5-6"	SBE303			
<b>80-97 F-350 4WD</b>					
	2-3"		SBE304		
	3.5-5"		SBE305		

# ACCESSORIES

<b>87-97 Ranger, Bronco II 4WD</b>					
	3-4"	SBE638			
	5-6"	SBE734			
<b>87-97 Ranger 2WD</b>					
	4-6"	SBE638			
<b>90-94 Explorer 4WD, 2WD</b>					
	3-4"	SBE734			
SWAY BAR LOWERING KITS					
Description	LIFT	Part #			
<b>80-96 F-100, F-150 4WD, 2WD</b>					
	4-6"	SBL20			
<b>80-96 Bronco 4WD, 2WD</b>					
	4-6"	SBL20			
<b>83-97 Ranger 4WD, 2WD</b>					
	4-6"	SBL20			
<b>83-90 Bronco II 4WD, 2WD</b>					
	4-6"	SBL20			
<b>90-94 Explorer 4WD, 2WD</b>					
	4-6"	SBL20			
SWAY BAR BUSHING KITS					
Description		Part #			
<b>66-79 F-100, F-150 4WD</b>					
		TAB75			
<b>66-75 Bronco 4WD</b>					
		TAB75			
<b>78-79 Bronco 4WD</b>					
		TAB75			
<b>76-77 Bronco 4WD</b>					
		TAB77			
TRACK BAR COMPONENTS					
Description	LIFT	Part #	NOTES		
<b>08-18 F-250, F-350, Super Duty 4WD</b>					
Front Track Bar Bracket					
	2-2.5"	TB1120			
<b>05-07 F-250, F-350, Super Duty 4WD</b>					
Front Track Bar Bracket					
	2"	TB520			
<b>03/99-04 Excursion, F-250, F-350, Super Duty 4WD</b>					
Adjustable Replacement Front Track Bar					
	2-8"	FTBA99	V9		
KIT NOTES: V9. Requires Use of Aftermarket Differential Track Bar Bracket.					
<b>03/99-04 Excursion, F-250, F-350, Super Duty 4WD - Built After March '99</b>					
Front Track Bar Bracket - Lower (at Differential)					
	2"	TB9203			
Front Track Bar Bracket - Upper (at Frame)					
	4-8"	TB9483			
<b>99 F-250, F-350, Super Duty 4WD - Built Before March '99</b>					
Front Track Bar Bracket - Lower (at Differential)					
	2"	TB920			
Front Track Bar Bracket - Upper (at Frame)					
	4-8"	TB948			
<b>86-97 F-350 4WD</b>					
Front OEM Track Bar Drop Bracket					
	4-6"	TB35			
HONDA - ACCESSORIES					
SWAY BAR EXTENDED END LINKS					
End Links Include Polyurethane Bushings					
Description	LIFT	FRONT	REAR		LOCATION
<b>06-12 Honda Ridgeline 4WD</b>					
	2"	HR20SBL			
INTERNATIONAL - ACCESSORIES					
FRAME SHACKLE BUSHING KITS					
Description					
<b>72-81 SCOUT II, Terra, Traveler 4WD</b>					
	SE40S		Z2		
KIT NOTES: Z2. Shackle Kit Includes Enough Bushings for BOTH Front & Rear.					
SPRING EYE BUSHING KITS					
Description	FRONT	REAR	NOTES		
<b>Skyjacker® Softride®</b>					
<b>72-81 SCOUT II, Terra, Traveler 4WD</b>					
	SE40S	SE40S			



# ACCESSORIES

Front Track Bar Brace (Dana 30 & 44 Front Axle)		
2.5-6"	JKBRC34	
Rear Track Bar Bracket		
3.5-5"	JK24RTB	
KIT NOTES: Must have Skyjacker® Relocation Bracket.		
Rear Track Bar Brace (Dana 44 Rear Axle)		
2.5-6"	JKBRC15	
KIT NOTES: Must have Skyjacker® Relocation Bracket.		
<b>97-06 Wrangler TJ FRONT</b>		
Adjustable Front Track Bar Assembly		
4"	TBA10	
6"	TBA60	
8-9"	TBA80	
<b>97-06 Wrangler TJ REAR</b>		
Rear Track Bar Relocation Bracket		
2-4"	TJRTB	
Option for the Skyjacker® Kit For Use on Vehicles Equipped with Skyjacker® Kit		
6-9"	RTBA168	
<b>87-96 Wrangler YJ</b>		
Front OEM Track Bar Relocation Bracket		
2-5"	JB40F	
Rear OEM Track Bar Relocation Bracket		
2-5"	JB40	
Front Extended Track Bar		
6"	TBA70	
<b>84-01 Cherokee XJ 4WD, 2WD</b>		
Adjustable Front Track Bar Assembly		
2-5"	TBA10	
6"	TBA60	
8"	TBA80	
Front OEM Track Bar Relocation Bracket		
2-4"	JTBF	
<b>93-98 Grand Cherokee ZJ 4WD, 2WD</b>		
Adjustable Front Track Bar Assembly		
3-4"	TBA10	
Front OEM Track Bar Relocation Bracket		
3-4"	JTBF	
<b>5TH LINK TRACTION BAR</b>		
Part #	NOTES	
<b>87-96 Wrangler YJ 4WD</b>		
<b>5th Link Traction Bar Assembly</b>		
YJ5LK	E6	Fits Stock or Lifted YJ
KIT NOTES: E6. # YJ5LK - 5th Link Traction Bar is Highly Recommended for Skyjacker®'s 6" YJ Monolinear Kit & for Any Spring Over Applications.		
		
<b>5th Link Traction Bar Only - Universal</b>		
TB500K		
<b>TRANSFER CASE LOWERING KITS</b>		
Description	LIFT	Part #
<b>03-06 Wrangler TJ + Rubicon 4WD</b>	2-2.5"	TCL103
<b>03-06 Wrangler TJ + Rubicon 4WD</b>	3.5-4"	TCL153
<b>97-02 Wrangler TJ 4WD</b>	2-2.5"	TCL101
<b>97-02 Wrangler TJ 4WD</b>	3.5-4"	TCL151
<b>87-96 Wrangler YJ 4WD</b>	2-4"	TCL25
<b>76-86 CJ5, CJ7 &amp; CJ8 4WD</b>	2-4"	TCL35
<b>55-75 CJ5, CJ6 4WD</b>	2-4"	TCL45
<b>94-01 Cherokee XJ 4WD, 2WD</b>	3"	TCL31
<b>84-93 Cherokee XJ 4WD, 2WD</b>	3"	TCL30

# MAZDA - Accessories

<b>ALIGNMENT SHIMS</b>			
Description	DEGREE	Part #	
<b>90-94 Mazda Navajo &amp; 94-97 BSeries 4WD</b>			
Caster / Camber Shims	0-2	1039H	
<b>90-94 Mazda Navajo &amp; 94-97 BSeries 2WD</b>			
Caster / Camber Shims	0-2	1029H	
<b>CENTER HINGE DROP BRACKETS - PAIR</b>			
Description	LIFT	Part #	
<b>90-94 Mazda Navajo &amp; 94-97 BSeries 4WD</b>			
Heavy-Duty - Class I	4-6"	CHB35	
Heavy-Duty - Class II	4-6"	CHB352	
<b>CENTER HINGE PIVOT BUSHINGS</b>			
Re-Uses Existing OEM Metal Outer Shells		Part #	
<b>94-96 B Series Pickup 4WD</b>		CHB80	
<b>90-94 Mazda Navajo 4WD</b>		CHB80	
<b>RADIUS / STRUT ARM BUSHINGS</b>			
Description		Part #	
<b>OEM REPLACEMENT</b>			
<b>94-97 B Series Pickup 4WD, 2WD</b>		SAB83	
<b>91-94 Navajo 4WD, 2WD</b>		SAB83	
<b>SWAY BAR EXTENDED END LINKS</b>			
End Links Include Polyurethane Bushings			
		LOCATION	
Description	LIFT	FRONT	REAR
<b>90-94 Mazda Navajo 4WD, 2WD</b>			
	3-4"	SBE734	
<b>SWAY BAR LOWERING KITS</b>			
Description	LIFT	Part #	
<b>94-97 B Series Pickup 4WD</b>	4-6"	SBL20	
<b>91-94 Navajo 4WD, 2WD</b>	4-6"	SBL20	

# TOYOTA - ACCESSORIES

<b>DRAG LINK &amp; TIE ROD ASSEMBLIES</b>			
Description	LIFT	Part #	NOTES
<b>79-85 Pickup, 4Runner 4WD</b>			
Offset Adjustable Drag Link			
	5-7"	TDL5	V8
KIT NOTES: V8. 7" Lifts REQUIRE the Following: Modifying Factory Steering Arm so that Ball is Pointing Out the Top of Arm (Rather than Pointing Down).			
<b>FRAME SHACKLE BUSHING KITS</b>			
Description	FRONT	REAR	NOTES
<b>ORIGINAL EQUIPMENT</b>			
<b>79-85 Pickup, 4Runner 4WD</b>	SE31T		
<b>SPRING EYE BUSHING KITS</b>			
Description	FRONT	REAR	NOTES
<b>Skyjacker® Softride®</b>			
<b>79-85 Pickup, 4Runner 4WD</b>	SE30T		
<b>79-88 Pickup, 4Runner 4WD</b>		SE35T	
<b>89-95 Pickup, 4Runner 4WD</b>		SE39T	
<b>64-80 LandCruiser FJ40 4WD</b>	SE40L	SE40L	
<b>SWAY BAR EXTENDED END LINKS</b>			
End Links Include Polyurethane Bushings			
		LOCATION	
Description	LIFT	FRONT	REAR
<b>07-16 Tundra 4WD</b>			
	6"	TU76SBL	
<b>79-85 Pickup, 4Runner 4WD</b>			
	3-5"	SBE30	
<b>TRACK BAR COMPONENTS</b>			
Description	LIFT	Part #	NOTES
<b>79-85 Pickup, 4Runner 4WD</b>			
Front OEM Torque Bar Relocation Bracket			
	3-7"	TB30	

# UNIVERSAL APPLICATIONS - ACCESSORIES

<b>UNIVERSAL BODY LIFT BLOCKS</b>			
Description	SIZE		
2" Universal Body Lift Block	2"	BPS227B	
3" Universal Body Lift Block	3"	BPS237B	
<b>DEGREE SHIMS</b>			
Description	SIZE		
<b>FLAT - PAIR SHIMS FOR SPRINGS ON TOP OF AXLE (Tie Bolts Ordered Separately)</b>			
Description	DEGREE	Part #	
2-2.25" Wide Leaf Springs	4	WS30	
2.5" Wide Leaf Springs	4	WS325	
3" Wide Leaf Springs	4	WS430	
<b>CONTOURED - PAIR SHIMS FOR SPRINGS BELOW AXLE (Tie Bolts Ordered Separately)</b>			
Description	DEGREE	Part #	
1.75" Wide Leaf Springs	6	WSC61	
2.5" Wide Leaf Springs	6	WSC60	
2.5" Wide Leaf Springs	8	WSC80	
<b>HI-LIFT JACK</b>			
Polyurethane Isolator		HLI100	
<b>LIMITING STRAPS</b>			
All Applications			
Pair of 16" Limiting Straps - BLACK		LS16K	
Pair of 20" Limiting Straps - BLACK		LS20K	
Pair of 24" Limiting Straps - BLACK		LS24K	
Pair of 28" Limiting Straps - BLACK		LS28K	
Pair of 32" Limiting Straps - BLACK		LS32K	
<b>POLY BUMP STOPS - PAIR</b>			
	LIFT	FRONT	REAR
<b>Bump Stop with Single Stud Mount</b>			
	4.5"	BP45	BP45
<b>ROCK READY GRAB HANDLES</b>			
DESCRIPTION		Part #	
2" RR Grab Handles Pair-Red		RRGH20-R	
3" RR Grab Handles Pair-Red		RRGH30-R	
2" RR Grab Handles Pair-Black		RRGH20-K	
3" RR Grab Handles Pair-Black		RRGH30-K	
<b>ROCK READY GRAB HANDLES - RETAIL PACKAGING</b>			
2" RR Grab Handles Pair-Red		RRGH20RP-R	
3" RR Grab Handles Pair-Red		RRGH30RP-R	
2" RR Grab Handles Pair-Black		RRGH20RP-K	
3" RR Grab Handles Pair-Black		RRGH30RP-K	
<b>ROD ENDS &amp; JAM NUTS</b>			
<b>NG Rebuildable Rod Ends</b>			
			
Description	SIZE	Part #	
1.25" Rod Ends with .75" Bolt Hole			
- LEFT Hand Threads	1.25" X .75"	RR114X1L	
1.25" Rod Ends with .75" Bolt Hole			
- RIGHT Hand Threads	1.25" X .75"	RR114X1R	
.75" Rod Ends with .625" Bolt Hole			
- LEFT Hand Threads	.75" X .625"	RR34X58L	
.75" Rod Ends with .625" Bolt Hole			
- RIGHT Hand Threads	.75" X .625"	RR34X58R	
<b>Rebuild Kits for NG Rebuildable Rod Ends</b>			
1.25" Rod Ends with .75" Bolt Hole	1.25" X .75"	RBK114	
.75" Rod Ends with .625" Bolt Hole	.75" X .625"	RBK34	
<b>Heavy-Duty Kevlar® / Teflon® Lined Self-Lubricating Rod Ends</b>			
Description	SIZE	Part #	

# ACCESSORIES

1.25" Rod Ends with 1" Bolt Hole			
- LEFT Hand Threads	1.25" X 1"	RE114X1L	
1.25" Rod Ends with 1" Bolt Hole			
- RIGHT Hand Threads	1.25" X 1"	RE114X1R	
.75" Rod Ends with .75" Bolt Hole			
- LEFT Hand Threads	.75" X .75"	RE34X34L	
.75" Rod Ends with .75" Bolt Hole			
- RIGHT Hand Threads	.75" X .75"	RE34X34R	
<b>Jam Nuts</b>			
NOTES: The Following Jam Nuts can be Ued for both Rebuildable & Self-Lubricating Rod Ends			
1.25" Jam Nut with Fine Threads			
- LEFT Hand Threads	1.25"	114LFTJN	
1.25" Jam Nut with Fine Threads			
- RIGHT Hand Threads	1.25"	114RFTJN	
.75" Jam Nut with Fine Threads			
- LEFT Hand Threads	.75"	34LFTJN	
.75" Jam Nut with Fine Threads			
- RIGHT Hand Threads	.75"	34RFTJN	
<b>SPRING SPACER PLATES</b>			
Description	SIZE	Part #	
<b>ANY &amp; ALL - LEAF SPRING MODELS WITH 2.5-3" WIDE LEAF SPRINGS ON TOP OF REAR AXLE</b>			
2.5" Wide Leaf Spring Spacer Plates	.5"	SP1225	
3" Wide Leaf Spring Spacer Plates	.5"	SP1230	
<b>TIE BOLTS - PAIR</b>			
Description	SIZE	Part #	
3/8 x 3" Tie Bolts with Nuts	3/8" x 3"	3803	
3/8 x 6" Tie Bolts with Nuts	3/8" x 6"	3806	
3/8 x 10" Tie Bolts with Nuts	3/8" x 10"	3810	
5/16 x 3" Tie Bolts with Nuts	5/16" x 3"	5163	
7/16 x 4" Tie Bolts with Nuts	7/16" x 4"	7164	
7/16 x 6" Tie Bolts with Nuts	7/16" x 6"	7166	
1/2 x 4" Tie Bolts with Nuts	1/2" x 4"	1204	
1/2 x 6" Tie Bolts with Nuts	1/2" x 6"	1206	



# POLYURETHANE CLEARANCE KITS / BODY LIFTS

Skyjacker® has 2" & 3" Body Lifts available for the following Jeep Applications.

We also a 1" Clearance Kit available. This Kit Completely Replaces the factory rubber body mounts with a more durable, long-lasting Polyurethane material. 1" of Clearance Lift is attained by using 1" Taller Mounts.

Replacement Shocks are also recommended, but not required. (See Shock Application Guide - Page 188).

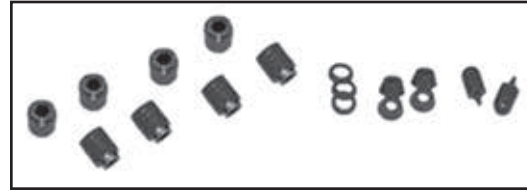

1" Lift Part #	2" Lift Part #	3" Lift Part #	Includes Bumper Brackets	Automatic or Manual Transmission	KIT NOTES
<b>JEEP</b>					
<b>97-06 Wrangler TJ + Rubicon - Clearance Kit</b>					
SS941P			(Clearance Kit)	Both	Ø21
KIT NOTES: Ø21. Completely Replaces Factory Body Mounts. 1" of Clearance Lift Attained by Using 1" Taller Polyurethane Mounts.					
<b>97-06 Wrangler TJ + Rubicon</b>					
SS951	SS952			Both	
<b>87-96 Wrangler YJ</b>					
<b>87-96 Wrangler YJ - Clearance Kit</b>					
SS931P			(Clearance Kit)	Both	Ø20
KIT NOTES: Ø20. Completely Replaces Factory Body Mounts. 1" of Clearance Lift Attained by Using 1" Taller Polyurethane Mounts. 1" Motor Mount Kit # MM100 (6 Cylinder ONLY) is Recommended to Maintain Proper Cooling Fan to Radiator Alignment & Eliminates Trimming of Radiator Shroud.					
<b>87-96 Wrangler YJ with Manual Transmission Only</b>					
SS931	SS932	SS933		Manual Only	
<b>87-96 Wrangler YJ with Automatic Transmission Only</b>					
SS931	SS932A	SS933A		Auto Only	
<b>72-86 CJ5, CJ7 &amp; Scrambler</b>					
<b>80-86 CJ5, CJ7 - Clearance Kit</b>					
SS951P			(Clearance Kit)	Both	Ø20
KIT NOTES: Ø20. Completely Replaces Factory Body Mounts. 1" of Clearance Lift Attained by Using 1" Taller Polyurethane Mounts. 1" Motor Mount Kit # MM100 (6 Cylinder ONLY) is Recommended to Maintain Proper Cooling Fan to Radiator Alignment & Eliminates Trimming of Radiator Shroud.					
<b>76-79 CJ5, CJ7 - Clearance Kit</b>					
SS961P			(Clearance Kit)	Both	Ø20
<b>UNIVERSAL</b>					
<b>Universal Body Lift Blocks - Single</b>					
	BPS227B			Both	
	BPS237B			Both	

**WARNING. . . Skyjacker® Suspensions Does NOT Recommend the Combined Use of Body Lifts & Suspension Lifts or Other Lifting Devices.**

# ADD-A-LEAFS

Softride® is the best way of describing the ride quality of our Long Add-A-Leafs. The Softride® Long Add-A-Leafs will bring new life & lift to your fatigued stock springs & you can rest easy knowing that the Skyjacker® Softride® Technology is at work in each pair.

Also available are the Heavy-Duty Add-A-Leafs. These units are shorter & are designed for extra payload capacity.

Tie Bolts are included in each Pair of Skyjacker® Add-A-Leafs.

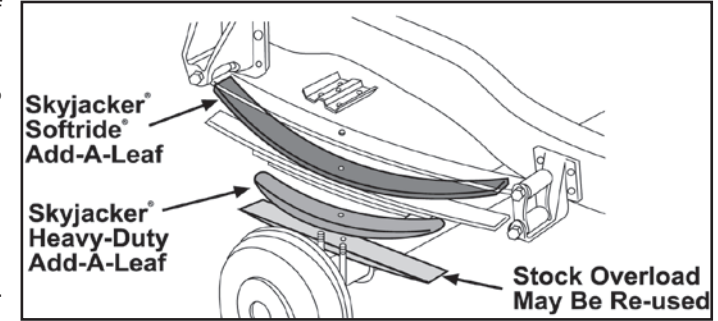

Also available are 'Fitted Leafs'. Fitted Leafs are designed as an option Exclusively for Skyjacker® Softride® Lifted Leaf Springs. These are used when the additional weight of aftermarket accessories are installed such as a heavy winch bumper, an engine conversion, a swing-away tire carrier, all your extra gear, etc.). The Fitted Leafs Application are listed in the Leaf Spring Charts. Start at Page 222 for Front & Page 225 for Rear Applications.

ADD-A-LEAFS - PAIR WITH TIE BOLTS														
FRONT	FRONT	FRONT	REAR	REAR	REAR	Front Shocks				Rear Shocks				KIT
LIFT	SOFTTRIDE®	HEAVY-DUTY	LIFT	SOFTTRIDE®	HEAVY-DUTY	HYDRO	NITRO	Black MAX	M95	HYDRO	NITRO	Black MAX	M95	NOTES
<b>CHEVROLET / GMC</b>														
<b>04-12 Colorado / Canyon 4WD / 2WD</b>														
			2.5"	RCC25						H7084	N8084	B8584	M9584	
<b>99-17 1500 &amp; 2500 Pickup 4WD - IFS</b>														
			1.5"	R1115						H7017	N8017	B8517	M9517	
<b>88-98 1500, 2500 Pickup 4WD - IFS</b>														
			2"	R1120	R225					H7083	N8083	B8583	M9583	
<b>67-87 1500, 2500 &amp; 3500 Pickup 4WD</b>														
<b>73-87 1500 &amp; 2500 Pickup 4WD</b>														
2"	F1100		2"	R1120	R225	H7051	N8051	B8551	M9551	H7053	N8053	B8553	M9553	
<b>67-72 1500 &amp; 2500 Pickup 4WD</b>														
2"	F1100		2"	R1120	R225	H7051	N8051	B8551	M9551	H7041	N8041	B8541	M9541	
<b>73-87 1 Ton Pickup 4WD</b>														
1.5-2"	F1100		1.5-2"	R1120	R225	H7051	N8051	B8551	M9551	H7053	N8053	B8553	M9553	
<b>67-91 Blazer / Jimmy 4WD</b>														
<b>73-91 Blazer / Jimmy 4WD</b>														
2"	F1100		2"	R1120	R225	H7051	N8051	B8551	M9551	H7053	N8053	B8553	M9553	
<b>67-72 Blazer / Jimmy 4WD</b>														
2"	F1100		2"	R1120	R225	H7051	N8051	B8551	M9551	H7041	N8041	B8541	M9541	
<b>67-91 Suburban 4WD</b>														
<b>73-91 Suburban 4WD</b>														
2"	F1100		1.5-2"	R1120	R225	H7051	N8051	B8551	M9551	H7053	N8053	B8553	M9553	
<b>67-72 Suburban 4WD</b>														
2"	F1100				R225	H7051	N8051	B8551	M9551	H7041	N8041	B8541	M9541	
<b>83-97 S10 / S15 Models 4WD - Except ZR2</b>														
			2"		R225					H7083	N8083	B8583	M9583	
<b>DODGE</b>														
<b>61-12 1/2, 3/4 &amp; 1 Ton Ram Pickup 4WD</b>														
<b>03-13 2500 / 03-12 3500 Ram Pickup 4WD</b>														
			2"		R332					H7017	N8017	B8517	M9517	
			4"		R334					H7017	N8017	B8517	M9517	
<b>94-01 1/2 &amp; 3/4 Ton Ram Pickup 4WD with 2.5" Wide Rear Springs</b>														
			2"		R222					H7017	N8017	B8517	M9517	
			4"		R224					H7017	N8017	B8517	M9517	
<b>94-02 3/4 &amp; 1 Ton Ram Pickup 4WD with 3" Wide Rear Springs</b>														
			1-1.5"		R372					H7036	N8036	B8536	M9536	
			3"		R370					H7036	N8036	B8536	M9536	
<b>61-93 1/2, 3/4 &amp; 1 Ton Pickup 4WD Full-Size</b>														
2"	F1100		2"	R1120	R225	H7027	N8027	B8527	M9527	H7038	N8038	B8538	M9538	

# ADD-A-LEAFS

ADD-A-LEAFS - PAIR WITH TIE BOLTS														
FRONT	FRONT	FRONT	REAR	REAR	REAR	Front Shocks				Rear Shocks				KIT
LIFT	SOFTRIDE®	HEAVY-DUTY	LIFT	SOFTRIDE®	HEAVY-DUTY	HYDRO	NITRO	Black MAX	M95	HYDRO	NITRO	Black MAX	M95	NOTES
<b>FORD</b>														
<b>66-18 F-100, F-150 Pickup 4WD, 2WD</b>														
<b>09-18 F-150 Pickup 4WD</b>														
			4"		R3940					H7060	N8060	B8560	M9560	
<b>04-08 F-150 Pickup 4WD</b>														
			4"		R3440					H7060	N8060	B8560	M9560	
<b>97-03 F-150 Pickup 4WD</b>														
			2"		R2520					H7061	N8061	B8561	M9561	
<b>80-96 F-100, F-150 Pickup 4WD</b>														
			2"		R3120	R300				H7060	N8060	B8560	M9560	
<b>80-96 F-100, F-150 Pickup 2WD</b>														
			2"		R225					H7058	N8058	B8558	M9558	
<b>73-79 F-100, F-150 Pickup 4WD</b>														
			2"		R3120	R300				H7057	N8057	B8557	M9557	
<b>70-72 F-100, F-150 Pickup 4WD</b>														
			2"		R225					H7057	N8057	B8557	M9557	
<b>66-69 F-100, F-150 Pickup 4WD</b>														
			2"		R225					H7041	N8041	B8541	M9541	
<b>00-05 Excursion 4WD</b>														
2.5 -3"	F9320		2.5"	R300		H7023	N8023	B8523	M9523	H7034	N8034	B8534	M9534	Q9
KIT NOTES: Q9. Front Add-A-Leafs REQUIRE # TB9203 Track Bar Bracket.														
<b>08-16 F-250 Super Duty 4WD</b>														
			1.5"		R3815					H7060	N8060	B8560	M9560	
<b>05-07 F-250 Super Duty 4WD</b>														
			1"		R3510					H7060	N8060	B8560	M9560	
			2.5"		R300					H7060	N8060	B8560	M9560	
<b>99-04 F-250 Super Duty 4WD</b>														
<b>99-04 F-250 Super Duty 4WD - Built AFTER March '99</b>														
2-2.5"	F9320		2.5"	R300		H7023				H7079	N8079	B8579	M9579	Q9
KIT NOTES: Q9. Front Add-A-Leafs REQUIRE # TB9203 Track Bar Bracket.														
<b>99-04 F-250 Super Duty 4WD - Built BEFORE March '99</b>														
2-2.5"	F9320		2.5"	R300		H7023				H7079	N8079	B8579	M9579	Q10
KIT NOTES: Q10. Front Add-A-Leafs REQUIRE # TB920 Track Bar Bracket.														
<b>80-98 F-250 4WD, 2WD</b>														
<b>87-98 F-250 4WD IFS with 460 &amp; Diesel Engine</b>														
2"	F46D		1.5-2"	R3120	R300	H7023				H7060	N8060	B8560	M9560	
<b>87-98 F-250 4WD IFS with 302 &amp; 351 Gas Engine</b>														
2"	F35G		1.5-2"	R3120	R300	H7023				H7060	N8060	B8560	M9560	
<b>80-86 F-250 4WD IFS with 460 &amp; Diesel Engine</b>														
2"	F46D		1.5-2"	R3120	R300	H7054				H7060	N8060	B8560	M9560	
<b>80-86 F-250 4WD IFS with 302 &amp; 351 Gas Engine</b>														
2"	F35G		1.5-2"	R3120	R300	H7054				H7060	N8060	B8560	M9560	
<b>80-98 F-250 2WD</b>														
			2"		R225					H7058	N8058	B8558	M9558	
<b>66-79 F-250 4WD</b>														
<b>77-5-79 F-250 4WD</b>														
2"	F46D		1.5-2"	R3120	R300					H7057	N8057	B8557	M9557	
<b>66-77 F-250 4WD</b>														
			1.5-2"		R225					H7058	N8058	B8558	M9558	
<b>08-18 F-350 Super Duty 4WD</b>														
			1.5"		R3815					H7060	M9560	B8560	M9560	
<b>05-07 F-350 Super Duty 4WD</b>														
			1"		R3510					H7060	M9560	B8560	M9560	
			2.5"		R300									
<b>99-04 F-350 Super Duty 4WD</b>														
2-2.5"	F9320		2.5"	R300		H7023	N8023	B8523	M9523	H7079	N8079	B8579	M9579	

# ADD-A-LEAFS

ADD-A-LEAFS - PAIR WITH TIE BOLTS														
FRONT	FRONT	FRONT	REAR	REAR	REAR	Front Shocks				Rear Shocks				KIT
LIFT	SOFTRIDE®	HEAVY-DUTY	LIFT	SOFTRIDE®	HEAVY-DUTY	HYDRO	NITRO	Black MAX	M95	HYDRO	NITRO	Black MAX	M95	NOTES
<b>86-98 F-350 &amp; Super Duty 4WD</b>														
<b>86-98 F-350 4WD - Except Crew Cabs</b>														
1.5"	F35G		1.5-2"	R3120	R300	H7023	N8023	B8523	M9523	H7060	N8060	B8560	M9560	
<b>86-98 F-350 &amp; Super Duty 4WD</b>														
<b>86-98 F-350 Crew Cab 4WD</b>														
2-2.5"	F35G+F46D		1.5-2"	R3120	R300	H7023	N8023	B8523	M9523	H7060	N8060	B8560	M9560	Q11
KIT NOTES: Q11. Front Add-A-Leafs REQUIRE # UFF Front U-Bolt Kit.														
<b>80-85 F-350 &amp; Super Duty 4WD</b>														
<b>80-85 F-350 4WD IFS with 460 &amp; Diesel Engine</b>														
2"	F46D		1.5-2"	R3120	R300	H7054	N8054	B8554	M9554	H7060	N8060	B8560	M9560	
<b>80-85 F-350 4WD IFS with 302 &amp; 351 Gas Engine</b>														
2"	F35G		1.5-2"	R3120	R300	H7054	N8054	B8554	M9554	H7060	N8060	B8560	M9560	
<b>66-96 Bronco</b>														
<b>80-96 Bronco 4WD</b>														
			2"		R3120	R300				H7058	N8058	B8558	M9558	
<b>78-79 Bronco 4WD</b>														
			2"		R3120	R300				H7026	N8026	B8526	M9526	
<b>67-77 Bronco 4WD</b>														
			2"		R225					H7058	N8058	B8558	M9558	
<b>66 Bronco 4WD</b>														
			2"		R225					H7055	N8055	B8555	M9555	
<b>83-97 Ranger, Bronco II, Explorer 4WD, 2WD</b>														
<b>83-97 Ranger 4WD</b>														
			2"		R3135					H7060	N8060	B8560	M9560	
<b>83-97 Ranger 2WD</b>														
			2"		R3135					H7058	N8058	B8558	M9558	
<b>83-90 Bronco II 4WD</b>														
			2"		R3135					H7058	N8058	B8558	M9558	
<b>90-94 Explorer 4WD, 2WD</b>														
			2"		R225					H7029	N8029	B8529	M9529	
<b>JEEP</b>														
<b>84-01 Cherokee XJ 4WD, Comanche Pickup</b>														
<b>84-01 Cherokee XJ 4WD</b>														
			2"		R3136					H7018	N8018	B8518	M9518	
<b>86-92 Comanche Pickup</b>														
			2"		R3136					H7023	N8023	B8523	M9523	
<b>TOYOTA</b>														
<b>95.5-18 Tundra 4WD, Tacoma 4WD, 2WD</b>														
<b>00-06 Tundra 4WD</b>														
			2"		RTU20					H7048	N8048	B8548	M9548	
<b>05-18 Tacoma 4WD, 2WD</b>														
			2"		RTC515					H7056	N8056	B8556	M9556	
<b>95.5-04 Tacoma 4WD, 2WD</b>														
			2"		RTC20					H7027	N8027	B8527	M9527	
<b>79-95 Pickup 4WD</b>														
<b>89-95 Pickup 4WD</b>														
			2"		R225					H7047	N8047	B8547	M9547	
<b>84-88 Pickup 4WD</b>														
			2"		R5005					H7027	N8027	B8527	M9527	
<b>79-83 Pickup 4WD</b>														
			2"		R5005					H7058	N8058	B8558	M9558	
<b>85-89 4Runner 4WD</b>														
			2"		R225					H7047	N8047	B8547	M9547	

# BRAKE LINES

STAINLESS STEEL BRAIDED BRAKE LINES					
	LIFT	FRONT	UNIT	REAR	UNIT
<b>CHEVROLET / GMC</b>					
<b>04-12 Colorado / Canyon 4WD</b>					
	3-4"	FBL48	Pair		
<b>88-98 1/2 &amp; 3/4 Ton Pickup 4WD</b>					
<b>88-98 1/2 &amp; 3/4 Ton Pickup 4WD</b>					
	0-3"	FBL97	Pair	RBL88	Single
	4-6"	FBL88	Pair	RBL88	Single
<b>07-16 Chevy / GMC 1500 4WD</b>					
	6"	FBL83	Pair	-----	-----
<b>68-87 1/2 &amp; 3/4 Ton Pickup 4WD (3/4 Tons 7200 GVWR or Less)</b>					
<b>79-87 1/2 &amp; 3/4 Ton Pickup 4WD (3/4 Tons 7200 GVWR or Less)</b>					
	3-4"	FBL17	Pair	RBL21	Single
	6-8"	FBL19	Pair	RBL20	Single
<b>73-78 1/2 &amp; 3/4 Ton Pickup 4WD (3/4 Tons 7200 GVWR or Less)</b>					
	3-4"	FBL16	Pair	RBL21	Single
	6-8"	FBL18	Pair	RBL20	Single
<b>70-72 1/2 &amp; 3/4 Ton Pickup 4WD with Disc Brakes (3/4 Tons 7200 GVWR or Less)</b>					
	3-4"	FBL16	Pair	RBL12	Single
	6-8"	FBL18	Pair	RBL13	Single
<b>68-69 1/2 &amp; 3/4 Pickup Ton 4WD With Drum Brakes ONLY - Will NOT Fit Suburbans</b>					
	3-4"	FBL12	Pair	RBL12	Single
	6-8"	FBL13	Pair	RBL13	Single
<b>68-87 3/4 &amp; 1 Ton Pickup 4WD (3/4 Tons 8600 GVWR or Greater)</b>					
<b>79-87 3/4 &amp; 1 Ton Pickup 4WD (3/4 Tons 8600 GVWR or Greater)</b>					
	3-4"	FBL27	Pair	RBL21	Single
	6-8"	FBL29	Pair	RBL20	Single
<b>73-78 3/4 &amp; 1 Ton Pickup 4WD (3/4 Tons 8600 GVWR or Greater)</b>					
	3-4"	FBL26	Pair	RBL21	Single
	6-8"	FBL28	Pair	RBL20	Single
<b>70-72 3/4 &amp; 1 Ton Pickup 4WD (3/4 Tons 8600 GVWR or Greater)</b>					
	3-4"	FBL26	Pair	RBL12	Single
	6-8"	FBL28	Pair	RBL13	Single
<b>68-69 1/2 &amp; 3/4 Pickup Ton 4WD with Drum Brakes ONLY - Will NOT Fit Suburbans</b>					
	3-4"	FBL12	Pair	RBL12	Single
	6-8"	FBL13	Pair	RBL13	Single
<b>68-98 Blazer / Jimmy, Tahoe / Yukon 4WD - Full-Size</b>					
<b>92-98 Blazer / Jimmy, Tahoe / Yukon 4WD - Full-Size</b>					
	0-3"	FBL97	Pair	RBL88	Single
	4-6"	FBL88	Pair	RBL88	Single
<b>79-91 Blazer / Jimmy 4WD - Fullsize</b>					
	3-4"	FBL17	Pair	RBL21	Single
	6-8"	FBL19	Pair	RBL20	Single
<b>73-78 Blazer / Jimmy 4WD - Full-Size</b>					
	3-4"	FBL16	Pair	RBL21	Single
	6-8"	FBL18	Pair	RBL20	Single

STAINLESS STEEL BRAIDED BRAKE LINES					
	LIFT	FRONT	UNIT	REAR	UNIT
<b>70-72 Blazer / Jimmy 4WD - Full-Size - with Disc Brakes</b>					
	3-4"	FBL16	Pair	RBL12	Single
	6-8"	FBL18	Pair	RBL13	Single
<b>68-69 Blazer 4WD with Drum Brakes ONLY - Will NOT Fit Suburbans</b>					
	3-4"	FBL12	Pair	RBL12	Single
	6-8"	FBL13	Pair	RBL13	Single
<b>70-98 Suburban 4WD</b>					
<b>92-98 Suburban 4WD</b>					
	0-3"	FBL97	Pair	RBL88	Single
	4-6"	FBL88	Pair	RBL88	Single
<b>79-91 Suburban 4WD</b>					
	3-4"	FBL27	Pair	RBL21	Single
	6-8"	FBL29	Pair	RBL20	Single
<b>73-78 Suburban 4WD</b>					
	3-4"	FBL26	Pair	RBL21	Single
	6-8"	FBL28	Pair	RBL20	Single
<b>70-72 Suburban 4WD</b>					
	3-4"	FBL26	Pair	-----	-----
	6-8"	FBL28	Pair	-----	-----
<b>DODGE</b>					
<b>94-02 1/2, 3/4 &amp; 1 Ton Ram Pickup 4WD</b>					
<b>94-01 1/2, 94-02 3/4 &amp; 1 Ton Ram Pickup 4WD</b>					
	1-4"	-----	-----	RBL60	Single
<b>61-93 1/2, 3/4 &amp; 1 Ton Pickup, Ramcharger, Trailduster 4WD</b>					
<b>82-93 1/2, 3/4 &amp; 1 Ton Pickup, Ramcharger, Trailduster 4WD</b>					
	4-8"	FBL60	Single	RBL60	Single
<b>76-81 1/2, 3/4 &amp; 1 Ton Pickup, Ramcharger, Trailduster 4WD</b>					
	4-8"	FBL60	Single	RBL61	Single
<b>72-75 1/2, 3/4 &amp; 1 Ton Pickup, Ramcharger, Trailduster 4WD</b>					
	4-8"	FBL65	Single	RBL65	Single
<b>69-71 1/2, 3/4 &amp; 1 Ton Pickup, Ramcharger, Trailduster 4WD</b>					
	4-8"	FBL61	Single	-----	Single
<b>61-68 1/2, 3/4 &amp; 1 Ton Pickup, Ramcharger, Trailduster 4WD</b>					
	4-8"	FBL61	Single	-----	-----
	LIFT	FRONT	UNIT	REAR	UNIT
<b>FORD</b>					
<b>66-96 F-100, F-150 4WD, 2WD</b>					
<b>90-96 F-150 4WD, 2WD</b>					
	4-8"	FBL81	Pair	RBL80	Single
<b>80-89 F-150 4WD, 2WD</b>					
	4-8"	FBL80	Pair	RBL80	Single
<b>76-79 F-100, F-150 4WD</b>					
	3-9"	FBL78	Single	RBL76	Single
<b>66-75 F-100, F-150 4WD</b>					
	3-9"	-----	-----	RBL76	Single
<b>73-10 F-250, F-350, Super Duty / Excursion 4WD, 2WD</b>					
<b>08-10 F-250 / F-350 Super Duty 4WD</b>					
	4"	FBL84	Pair		
	6-8"	FBL86	Pair		

STAINLESS STEEL BRAIDED BRAKE LINES					
	LIFT	FRONT	UNIT	REAR	UNIT
<b>05-07 F-250 / F-350 Super Duty 4WD</b>					
	4"	FBL54	Pair		
	6-8"	FBL56	Pair		
<b>FORD - CONTINUED</b>					
<b>2004 F-250 / F-350 Super Duty / Excursion 4WD</b>					
	4-6"	FBL92	Pair	RBL99	
<b>00-03 F-250 / F-350 Super Duty / Excursion 4WD</b>					
	4-8"	FBL92	Pair	RBL99	Single
<b>99 F-250 / F-350 Super Duty / Excursion 4WD</b>					
	4-8"	FBL99	Pair	RBL99	Single
<b>90-98 F-250, F-350 4WD, 2WD</b>					
	4-6"	FBL91	Pair	RBL90	Single
<b>80-89 F-250, F-350 4WD, 2WD - ONLY Fits Vehicles with a 7/16" Banjo Bolt</b>					
	4-6"	FBL90	Pair	RBL90	Single
<b>76-79 F-250, F-350 4WD</b>					
	4-6"	FBL93	Pair	RBL93	Single
<b>73-75 F-250, F-350 4WD</b>					
	4-6"	FBL95	Pair	RBL95	Single
<b>66-96 Bronco 4WD</b>					
<b>90-96 Bronco 4WD</b>					
	4-8"	FBL81	Pair	RBL80	Single
<b>80-89 Bronco 4WD</b>					
	4-8"	FBL80	Pair	RBL80	Single
<b>78-79 Bronco 4WD</b>					
	3-9"	FBL78	Single	RBL76	Single
<b>66-77 Bronco 4WD</b>					
	3-7"	FBL77	Single	RBL77	Single
<b>83-97 Ranger, Bronco II, Explorer 4WD, 2WD</b>					
<b>89-97 Ranger, Bronco II - Will NOT Fit with ABS</b>					
	4-6"	FBL36	Pair	RBL35	Single
<b>83-88 Ranger, Bronco II 4WD, 2WD</b>					
	4-6"	FBL35	Pair	RBL35	Single
<b>83-97 Ranger, Bronco II 4WD, 2WD with 8" Lift - Will NOT Fit with ABS</b>					
	8"	FBL38	Pair	RBL35	Single
<b>90-94 Explorer 4WD, 2WD - Will NOT Fit with ABS</b>					
	4-6"	FBL36	Pair	RBL35	Single
<b>MAZDA</b>					
<b>94-97 Mazda B4000 4WD, 2WD - Will NOT Fit with ABS</b>					
	4-6"	FBL36	Pair	RBL35	Single
<b>91-94 Navajo 4WD - Will NOT Fit with ABS</b>					
	4-6"	FBL36	Pair	RBL35	Single
<b>JEEP</b>					
<b>87-18 Wrangler 4WD</b>					
<b>07-18 Wrangler JK 4WD</b>					
	4-7"	JKFBL60	Pair	JKRBL60	Pair
<b>97-06 Wrangler TJ 4WD</b>					
	4-8"	FBL44	Pair	RBL98	Single
<b>87-96 Wrangler YJ 4WD</b>					
	3.5-6"	FBL47	Pair	RBL47	Single

STAINLESS STEEL BRAIDED BRAKE LINES					
	LIFT	FRONT	UNIT	REAR	UNIT
<b>55-86 CJs &amp; Scrambler 4WD</b>					
<b>82-86 CJs &amp; Scrambler 4WD</b>					
	0-2.5"	FBL402	Pair	RBL402	Single
	3-5"	FBL40	Pair	RBL40	Single
<b>76-81 CJs &amp; Scrambler 4WD with Disc Brakes</b>					
	0-2.5"	FBL412	Pair	RBL402	Single
	3-5"	FBL41	Pair	RBL40	Single
<b>76-81 CJs &amp; Scrambler 4WD with Drum Brakes</b>					
	0-2.5"	-----	-----	Pair	RBL402
	3-5"	FBL46	Pair	RBL40	Single
<b>74-75 CJs 4WD</b>					
	2.5-4"	FBL42	Pair	RBL42	Single
<b>67-73 CJs 4WD</b>					
	2.5-4"	FBL43	Pair	RBL43	Single
<b>55-66 CJs 4WD</b>					
	2.5-4"	FBL45	Pair	RBL45	Single
<b>84-01 Cherokee XJ 4WD</b>					
<b>84-01 Cherokee XJ 4WD</b>					
	3-8"	FBL44	Pair	RBL44	Single
<b>74-83 Cherokee, Wagoneer 4WD Full-Size</b>					
<b>79-83 Cherokee, Wagoneer 4WD - Full-Size</b>					
	2.5-4"	FBL40	Pair	RBL41	Single
<b>74-78 Cherokee, Wagoneer 4WD - Full-Size - with Disc Brakes</b>					
	2.5-4"	FBL41	Pair	RBL41	Single
<b>84-91 Grand Wagoneer 4WD - Full-Size</b>					
	2.5-4"	FBL40	Pair	RBL41	Single
<b>74-88 J10, J20 Pickup 4WD Full Size</b>					
<b>79-88 J10, J20 Pickup 4WD Full-Size - with Disc Brake Only</b>					
	2.5-4"	FBL40	Pair	RBL41	Single
<b>74-78 J10, J20 Pickup 4WD Full-Size - with Disc Brake Only</b>					
	2.5-4"	FBL41	Pair	RBL41	Single
<b>TOYOTA</b>					
<b>79-95 Pickup &amp; 4Runner 4WD</b>					
	3-7"	FBL30	Pair	RBL30	Single
<b>64-82 LandCruiser FJ40 4WD - Will NOT Fit 64-74 LandCruiser with Front 2-Line Wheel Cylinder</b>					
	2-4"	FBL31	Single	RBL30	Single
<b>INTERNATIONAL</b>					
<b>74-80 Scout II 4WD</b>					
	2-4"	FBL50	Pair	RBL50	Single

# SOFRIDE® COIL SPRINGS

LIFT	COILS - PAIR		KIT
	Height	Front	
<b>CHEVROLET / GMC</b>			
<b>00-06 GM Avalanche, Tahoe, Suburban, Yukon 4WD</b>			
4.5"		C50R	
<b>DODGE</b>			
<b>13-18 2500 / 3500 Ram Pickup 4WD - Diesel Engines</b>			
2-2.5"	R25		
4"	R45		
6"	R65		
<b>03-13 2500 / 03-12 3500 Ram Pickup 4WD V10 / Diesel Engines</b>			
3-4"	D25		
5-6"	D45		
<b>94-01 1/2 Ton Ram Pickup 4WD</b>			
<b>94-01 1/2 Ton Ram Pickup 4WD V-8 Engines</b>			
2"	D20		Q14
3"	D30		Q14
5"	D50		Q14
7"	D70		Q14
KIT NOTES: Q14. 00-01 Models Equipped with Factory 'OFF-ROAD Package' will Receive 1" Less Lift.			
<b>94-02 3/4 Ton Heavy Duty &amp; 1 Ton Ram Pickup 4WD with 3" Wide Rear Springs - V10 / Diesel Engines</b>			
2-2.5"	D25		
4-4.5"	D45		
7"	D75		
<b>FORD</b>			
<b>83-97 Ranger 4WD, 2WD Leveling Kits</b>			
<b>90-97 Ranger 4WD with 4 Cylinder Engine</b>			
1.5-2"	132		
<b>90-97 Ranger XLT 4WD with 6 Cylinder Engine</b>			
1.5-2"	132X		
<b>90-97 Ranger 2WD with 2.3, 2.9 &amp; 3.0 Liter Engine</b>			
1.5-2"	132		
<b>90-97 Ranger 2WD with 4.0 Liter Engine</b>			
1.5-2"	132X		
<b>87-89 Ranger STX 4WD</b>			
1.5-2"	132X		
<b>83-89 Ranger 4WD, 2WD - Except Super Cab with 2.9 Liter Engine</b>			
1.5-2"	132		
<b>83-89 Ranger Super Cab 4WD, 2WD with 2.9 Liter Engine</b>			
1.5-2"	132X		
<b>83-97 Ranger 4WD, 2WD - 4", 6" &amp; 8" Lifts</b>			
<b>83-97 Ranger 4WD, 2WD</b>			
4"	134		
6"	136		
8"	138		
<b>83-90 Bronco II 4WD, 2WD</b>			
<b>83-90 Bronco II 4WD, 2WD</b>			
1.5-2"	132		
4"	134		
6"	136		
8"	138		
<b>66-96 F-100, F-150 4WD, 2WD</b>			
<b>80-96 F-100, F-150 4WD, 2WD &amp; 80-96 Bronco 4WD</b>			
2"	182		
4"	184		
6"	186		
8"	188		
<b>66-79 F-100, F-150 4WD &amp; 78-79 Bronco 4WD</b>			

LIFT	COILS - PAIR		KIT
	Height	Front	
2"	172		
4"	174		
6"	176		
9"	179		
<b>66-77 Bronco 4WD</b>			
3"	172		
5"	174		
7"	176		
<b>05-18 F-250, F-350 4WD, Diesel</b>			
<b>05-18 F-250, F-350 4WD, Diesel</b>			
2"	F525V		
4"	F545V		
6"	F565V		
8.5"	F585V		
<b>05-18 F-250, F-350 4WD, GAS</b>			
2"	F520		
4"	F540		
6"	F560		
8.5"	F565V		
<b>02-10 Hummer H2</b>			
5.5"		H250R	
<b>JEEP</b>			
<b>07-18 Jeep Wrangler JK 2WD / 4WD 4 Door</b>			
2.5"	JK25FSR	JK25RSR	Softride® Coils
4"	JK40FSR	JK40RSR	Softride® Coils
6"	JK60F	JK60R	
<b>07-18 Jeep Wrangler JK 2WD / 4WD 2 Door</b>			
2"	JK20FSR	JK20RSR	Softride® Coils
3.5"	JK25FSR	JK25RSR	Softride® Coils
7"	JK60F	JK60R	
<b>97-06 Wrangler TJ / Rubicon 2WD / 4WD</b>			
2.5"	TJ25F	TJ25R	
4"	TJ40F	TJ40R	
6"	TJ60F	TJ60R	
8"	TJ80F	TJ80R	
<b>04-06 Wrangler Unlimited LJ 2WD / 4WD</b>			
2.5"	TJ25F	TJ25R*	
4"	TJ40F	TJ40R*	
6"	TJ60F	TJ60R*	
8"	TJ80F	TJ90R	
NOTES: * Part # SIP275 May be Required on Hard Top Models to Level the Rear.			
<b>08-12 Liberty KJ 2WD / 4WD</b>			
2"		LIB208R	
<b>02-07 Liberty KJ 2WD / 4WD</b>			
2.5"		LIB25R	
<b>84-01 Cherokee XJ 2WD / 4WD</b>			
3"	JC30F		
4.5"	JC45F		
6"	JC60F		
8"	JC80F		
<b>93-98 Grand Cherokee ZJ 2WD / 4WD</b>			
2"		GC20R	
3"	JC30F		
<b>86-92 Comanche MJ 2WD / 4WD</b>			
3"	JC30F		

# FRONT SOFRIDE® LEAF SPRINGS

**Softride® Technology** gives you all the vigorous off-road handling needed while providing the smooth street riding characteristics that you demand. Skyjacker's advanced method of shotpeening, tapered, leafs, Teflon® wear pads & 'presetting' process achieves articulation at its best...without sacrificing the life of the spring. From this chart, you can find a 'Pair of Springs with Bushings' or 'Single Springs' & the 'Bushings Sets' needed for the Single unit (Ordered Separately). Also available are 'Fitted Leafs'. Fitted Leafs are designed as an option Exclusively for Skyjacker® Softride® Lifted Leaf Springs. These are used when the additional weight of aftermarket accessories are installed such as a heavy winch bumper, an engine conversion, a swing-away tire carrier, all your extra gear, etc.).

FRONT LIFT	NOTES	SINGLE SPRING	QTY.	BUSHING SETS TO FIT 2 SINGLE SPRINGS	QTY.	FITTED LEAFS FOR PAIR
<b>CHEVROLET / GMC</b>						
<b>73-87 K15 &amp; K25 Pickup 4WD</b>						
2.5"		C125S	2	SE11C	1	FLC125
4"		C140S	2	SE11C	1	FLC140
6"		C160S	2	SE11C	1	FLC160
8"		C180S	2	SE11C	1	FLC180
<b>67-72 K15 &amp; K25 Pickup 4WD</b>						
2.5"		C225S	2	SE11C	1	FLC225
4"		C240S	2	SE11C	1	FLC240
6"		C260S	2	SE11C	1	FLC260
8"		C280S	2	SE11C	1	FLC280
<b>77-87 K30 Pickup 4WD</b>						
2.5"		C125S	2	SE11C	1	FLC125
4"		C140S	2	SE11C	1	FLC140
6"		C160S	2	SE11C	1	FLC160
8"		C180S	2	SE11C	1	FLC180
<b>88-91 K5 Blazer, Jimmy Full-Size</b>						
2.5"		C125S	2	SE17C	1	FLC125
4"		C140S	2	SE17C	1	FLC140
6"		C160S	2	SE17C	1	FLC160
8"		C180S	2	SE17C	1	FLC180
<b>73-87 K5 Blazer, Jimmy Full-Size</b>						
2.5"		C125S	2	SE11C	1	FLC125
4"		C140S	2	SE11C	1	FLC140
6"		C160S	2	SE11C	1	FLC160
8"		C180S	2	SE11C	1	FLC180
<b>67-72 K5 Blazer, Jimmy Full-Size</b>						
2.5"		C225S	2	SE11C	1	FLC225
4"		C240S	2	SE11C	1	FLC240
6"		C260S	2	SE11C	1	FLC260
8"		C280S	2	SE11C	1	FLC280
<b>88-91 Suburban K15 &amp; K25 4WD</b>						
2.5"		C125S	2	SE17C	1	FLC125
4"		C140S	2	SE17C	1	FLC140
6"		C160S	2	SE17C	1	FLC160
8"		C180S	2	SE17C	1	FLC180
<b>73-87 Suburban K15 &amp; K25 4WD</b>						
2.5"		C125S	2	SE11C	1	FLC125
4"		C140S	2	SE11C	1	FLC140
6"		C160S	2	SE11C	1	FLC160
8"		C180S	2	SE11C	1	FLC180
<b>67-72 Suburban K15 &amp; K25 4WD</b>						
2.5"		C225S	2	SE11C	1	FLC225
4"		C240S	2	SE11C	1	FLC240
6"		C260S	2	SE11C	1	FLC260
8"		C280S	2	SE11C	1	FLC280
<b>DODGE</b>						
<b>61-93 W150 &amp; W250 Pickup 4WD (GAS Engines)</b>						
2.5"		D200S	2	SE12D	1	FLD200
4"		D400S	2	SE12D	1	FLD400

# FRONT SOFTRIDE® LEAF SPRINGS

FRONT LIFT	NOTES	SINGLE SPRING	QTY.	BUSHING SETS TO FIT 2 SINGLE SPRINGS	QTY.	FITTED LEAFS FOR PAIR
<b>DODGE - CONTINUED</b>						
<b>61-93 W150 &amp; W250 Pickup 4WD (GAS Engines)</b>						
6"		D600S	2	SE12D	1	FLD600
8"		D800S	2	SE12D	1	FLD800
<b>87-93 W250 &amp; W350 Pickup 4WD (DIESEL Engines)</b>						
1"		D100CS	2	SE12D	1	FLD200
2"		D200CS	2	SE12D	1	FLD400
4"		D400CS	2	SE12D	1	FLD600
6"		D600CS	2	SE12D	1	FLD800
<b>74.5-93 W350 Pickup 4WD (GAS Engines)</b>						
1.5-2"		D200S	2	SE12D	1	FLD200
3-4"		D400S	2	SE12D	1	FLD400
5-6"		D600S	2	SE12D	1	FLD600
7-8"		D800S	2	SE12D	1	FLD800
<b>72-93 Ramcharger, Trailduster 4WD</b>						
2.5"		D200S	2	SE12D	1	FLD200
4"		D400S	2	SE12D	1	FLD400
6"		D600S	2	SE12D	1	FLD600
8"		D800S	2	SE12D	1	FLD800
<b>FORD</b>						
<b>00-05 Excursion 4WD (GAS Engines)</b>						
4"		F920S	2	SE90F	1	
6"		F940S	2	SE90F	1	
8"		F960S	2	SE90F	1	
<b>00-05 Excursion 4WD (DIESEL Engines)</b>						
6"		F945S	2	SE90F	1	
8"		F965S	2	SE90F	1	
<b>99-04 F-250, F-350 Super Duty 4WD (GAS Engines)</b>						
2"		F920S	2	SE90F	1	
4"		F940S	2	SE90F	1	
6"		F960S	2	SE90F	1	
8"		F965S	2	SE90F	1	
<b>99-04 F-250, F-350 Super Duty 4WD (DIESEL Engines)</b>						
1.5"		F920S	2	SE90F	1	
4"		F945S	2	SE90F	1	
6"		F965S	2	SE90F	1	
8"		F985S	2	SE90F	1	
<b>80-98 F-250 4WD</b>						
4"		F840S	2	SE80F	1	FLF840
6"		F860S	2	SE80F	1	FLF860
<b>77.5-79 F-250 4WD</b>						
4"		F724S	2	SE70F	1	FLF724
6"		F746S	2	SE70F	1	FLF746
<b>67-77 F-250 Highboy</b>						
2"		F724S	2	SE70F	1	FLF724
4"		F746S	2	SE70F	1	FLF746
<b>86-98 F-350 Monobeam Straight Axle 4WD</b>						
3-4"		F840S	2	SE80F	1	FLF840
5-6"		F860S	2	SE80F	1	FLF860
<b>80-85 F-350 IFS 4WD</b>						
4"		F840S	2	SE80F	1	FLF840
6"		F860S	2	SE80F	1	FLF860
<b>79 F-350 Low Boy</b>						
3-4"		F724S	2	SE70F	1	FLF724
5-6"		F746S	2	SE70F	1	FLF746

# FRONT SOFTRIDE® LEAF SPRINGS

FRONT LIFT	NOTES	SINGLE SPRING	QTY.	BUSHING SETS TO FIT 2 SINGLE SPRINGS	QTY.	FITTED LEAFS FOR PAIR
<b>JEEP</b>						
<b>87-96 Wrangler YJ</b>						
2-2.5"		YJ20FS	2	SE4YJ	1	FLYJ20F
3.5"-4"		YJ40FS	2	SE4YJ	1	FLYJ40F
<b>87-96 Wrangler YJ Rock Ready® Double Military Wrap</b>						
2.5"		YJ25FS	2	SE45YJ		
4"		YJ45FS	2	SE45YJ		
<b>76-86 CJ &amp; Scrambler</b>						
2-2.5"		J20FS	2	SE40J	1	FLJ20F
3.5"-4"		J40FS	2	SE40J	1	FLJ40F
<b>55-75 CJ</b>						
2-2.5"		J32FS	2	SE34J	1	FLJ32F
3.5"-4"		J34FS	2	SE34J	1	FLJ34F
<b>84-91 Grand Wagoneer 4WD Full-Size</b>						
3.5-4"		JP40FS	2	SE4JP	1	FLJP40F
<b>74-83 Cherokee, Wagoneer 4WD Full-Size</b>						
3.5-4"		JP40FS	2	SE4JP	1	FLJP40F
<b>74-88 J10, J20 Pickup 4WD Full-Size</b>						
3.5-4"		JP40FS	2	SE4JP	1	FLJP40F
<b>TOYOTA</b>						
<b>79-85 Pickup &amp; 4Runner 4WD</b>						
3"		T303S	2	SE30T	1	FLT303
5"		T305S	2	SE30T	1	FLT305
7"		T307S	2	SE30T	1	FLT307
<b>64-80 FJ40 LandCruiser 4WD</b>						
2.5"		L20FS	2	SE40L	1	FLL20F
4"		L40FS	2	SE40L	1	FLL40F
<b>INTERNATIONAL</b>						
<b>72-82 Scout II, Terra, Traveler 4WD</b>						
2"		S20FS	2	SE40S	1	FLS20F
4"		S40FS	2	SE40S	1	FLS40F
<b>JEEP SPORTS SERIES</b>						
<b>87-96 Wrangler YJ</b>						
2-2.5"		YJ20FSB	2	SE4YJ	1	FLYJ20F
3.5"-4"		YJ40FSB	2	SE4YJ	1	FLYJ40F
<b>76-86 CJ &amp; Scrambler</b>						
2-2.5"		J20FSB	2	SE40J	1	FLJ20F
3.5"-4"		J40FSB	2	SE40J	1	FLJ40F

# REAR SOFTRIDE® LEAF SPRINGS

**Softride® Technology** enhances every steely aspect of leaf spring performance, giving you all the vigorous off-road handling needed while providing the smooth street riding characteristics that you demand. Skyjacker's advanced method of shotpeening, tapered leaves, Teflon® wear pads & 'presetting' process achieves articulation at its best... without sacrificing the life of the spring. From this chart, you can find a 'Pair of Springs with Bushings' or 'Single Springs' & the 'Bushings Sets' needed for the Single unit (Ordered Separately). Also available are 'Fitted Leaves'. Fitted Leaves are designed as an option Exclusively for Skyjacker® Softride® Lifted Leaf Springs. These are used when the additional weight of aftermarket accessories are installed such as a heavy winch bumper, an engine conversion, a swing-away tire carrier, all you extra gear, etc.).

FRONT LIFT	NOTES	SINGLE SPRING	QTY.	BUSHING SETS TO FIT 2 SINGLE SPRINGS	QTY.	FITTED LEAFS FOR PAIR
<b>CHEVROLET / GMC</b>						
<b>99-18 1500 1500 Ton Pickup 4WD</b>						
5"		CR55S	2	Pre-Installed Rubber		
<b>01-08 1500HD / 2500 Pickup 4WD</b>						
5"		CR75S	2	Pre-Installed Rubber		
<b>01-10 2500HD / 3500HD 2500 &amp; 3500 Pickup 4WD</b>						
5"		CR75S	2	Pre-Installed Rubber		
<b>92-98 Blazer, Yukon, Tahoe 4WD</b>						
2"		CR12S	2	Pre-Installed Rubber		FLCR12
4"		CR14S	2	Pre-Installed Rubber		FLCR14
6"		CR16S	2	Pre-Installed Rubber		FLCR16
<b>88-98 1500, 2500 6 Lug Pickup 4WD</b>						
5-5.5"		CR35S	2	Pre-Installed Rubber		FLCR35
<b>69-87 1500, 2500 Pickup 4WD with 52" Rear Springs</b>						
2"		CR12S	2	Pre-Installed Rubber		FLCR12
4"		CR14S	2	Pre-Installed Rubber		FLCR14
6"		CR16S	2	Pre-Installed Rubber		FLCR16
8"		CR18S	2	Pre-Installed Rubber		FLCR18
<b>69-87 1500 &amp; 2500 Pickup 4WD with 56" Rear Springs</b>						
4"		CR24S	2	Pre-Installed Rubber		FLCR24
6"		CR26S	2	Pre-Installed Rubber		FLCR26
<b>73-91 Blazer, Jimmy 4WD</b>						
2"		CR12S	2	Pre-Installed Rubber		FLCR12
4"		CR14S	2	Pre-Installed Rubber		FLCR14
6"		CR16S	2	Pre-Installed Rubber		FLCR16
8"		CR18S	2	Pre-Installed Rubber		FLCR18
<b>69-72 Blazer, Jimmy 4WD</b>						
2"		CR14S	2	Pre-Installed Rubber		FLCR14
4"		CR16S	2	Pre-Installed Rubber		FLCR16
6"		CR18S	2	Pre-Installed Rubber		FLCR18
<b>69-91 Suburban 4WD with 52" Rear Springs</b>						
2"		CR14S	2	Pre-Installed Rubber		FLCR14
4"		CR16S	2	Pre-Installed Rubber		FLCR16
6"		CR18S	2	Pre-Installed Rubber		FLCR18
<b>69-91 Suburban 4WD with 56" Rear Springs</b>						
4"		CR24S	2	Pre-Installed Rubber		FLCR24
6"		CR26S	2	Pre-Installed Rubber		FLCR26
<b>DODGE</b>						
<b>02-08 1500 Ram Pickup 4WD</b>						
5"		DR250S	2	Pre-Installed Rubber		
<b>94-01 1500 &amp; 2500 Ram Pickup 4WD with 2.5" Wide Rear Springs</b>						
2"	Q7	DR56S	2	Pre-Installed Rubber		
4"		DR54S	2	Pre-Installed Rubber		FLDR54
<b>94-01 1500 &amp; 2500 Ram Pickup 4WD with 2.5" Wide Rear Springs</b>						
6"		DR56S	2	Pre-Installed Rubber		
KIT NOTES: Q7. The Factory Block is Removed.						
<b>10-12 2500 &amp; 3500 Ram Pickup 4WD</b>						
4"		DR174S	2	Pre-Installed Rubber		

# REAR SOFTRIDE® LEAF SPRINGS

FRONT LIFT	NOTES	SINGLE SPRING	QTY.	BUSHING SETS TO FIT 2 SINGLE SPRINGS	QTY.	FITTED LEAFS FOR PAIR
<b>03-09 2500 &amp; 3500 Ram Pickup 4WD</b>						
4"		DR374S	2	Pre-Installed Rubber		
<b>94-01 2500 Heavy Duty &amp; 3500 Ram Pickup 4WD with 3" Wide Rear Springs</b>						
1-1.5"	Q7	DR76S	2	Pre-Installed Rubber		FLDR76
4"		DR74S	2	Pre-Installed Rubber		FLDR74
6"		DR76S	2	Pre-Installed Rubber		FLDR76
KIT NOTES: Q7. The Factory Block is Removed.						
<b>72-93 1500 &amp; 2500 Pickup 4WD</b>						
4"	Q6	DR40S	2	Pre-Installed Rubber		FLDR40
6"	Q6	DR60S	2	Pre-Installed Rubber		FLDR60
KIT NOTES: Q6. Factory Block can be Removed to Reduce Lift 3.5" (Cummins Models will be 4-6" Less Lift). Some 2500 & 3500 Models have 2500" Spring Eye Bolts & REQUIRE Bushing Kit # SE17D.						
<b>72-93 Ramcharger, Trailduster 4WD</b>						
6"	Q6	DR40S	2	Pre-Installed Rubber		FLDR40
8"	Q6	DR60S	2	Pre-Installed Rubber		FLDR60
KIT NOTES: Q6. Factory Block can be Removed to Reduce Lift 3.5" (Cummins Models will be 4-6" Less Lift). Some 2500 & 3500 Models have 2500" Spring Eye Bolts & REQUIRE Bushing Kit # SE17D.						
<b>FORD</b>						
<b>09-14 F-150 4WD</b>						
4"		FR904S	2	Pre-Installed Rubber		
<b>04-08 F-150 4WD</b>						
4.5"		FR44S	2	Pre-Installed Rubber		FLFR44
<b>97-03 F-150 4WD Includes SuperCrew</b>						
5"		FR15S	2	Pre-Installed Rubber		
<b>73-96 F-100, F-150 4WD</b>						
2"		FR52S	2	Pre-Installed Rubber		FLFR52
4"	Q1	FR54S	2	Pre-Installed Rubber		FLFR54
6-8"	Q1	FR56S	2	Pre-Installed Rubber		FLFR56
KIT NOTES: Q1. Factory Block can be Removed on 4WD to Reduce Lift 2" on 80-86 Models or 3.25" on 73-79 Models.						
<b>80-96 F-100, F-150 2WD</b>						
2"		FR34S	2	Pre-Installed Rubber		
4"		FR36S	2	Pre-Installed Rubber		
<b>78-96 Bronco 4WD</b>						
2"		FR51S	2	Pre-Installed Rubber		FLFR51
4"		FR52S	2	Pre-Installed Rubber		FLFR52
6"		FR54S	2	Pre-Installed Rubber		FLFR54
8"		FR56S	2	Pre-Installed Rubber		FLFR56
<b>66-77 Bronco 4WD</b>						
4.5"		FR64S	2	Pre-Installed Rubber		FLFR64
<b>00-04 Excursion 4WD</b>						
4"		FR94S	2	Pre-Installed Rubber		
6"		FR96S	2	Pre-Installed Rubber		
8"		FR98S	2	Pre-Installed Rubber		
<b>80-98 F-250 4WD, 2WD</b>						
1-2"		FR52S	2	Pre-Installed Rubber		FLFR52
3-4"	Q1	FR54S	2	Pre-Installed Rubber		FLFR54
5-6"	Q1	FR56S	2	Pre-Installed Rubber		FLFR56
KIT NOTES: Q1. Factory Block can be Removed on 4WD to Reduce Lift 2" on 80-86 Models or 3.25" on 73-79 Models.						
<b>77.5-79 F-250 Lowboy 4WD</b>						
1-2"		FR52S	2	Pre-Installed Rubber		FLFR52
3-4"	Q3	FR54S	2	Pre-Installed Rubber		FLFR54
5-6"	Q3	FR56S	2	Pre-Installed Rubber		FLFR56
KIT NOTES: Q3. Factory Block can be Removed to Reduce Lift 3.25".						

# REAR SOFTRIDE® LEAF SPRINGS

FRONT LIFT	NOTES	SINGLE SPRING	QTY.	BUSHING SETS TO FIT 2 SINGLE SPRINGS	QTY.	FITTED LEAFS FOR PAIR
<b>FORD - CONTINUED</b>						
<b>17-18 F-250 / F-350 Super Duty 4WD</b>						
3"	<b>NEW</b>	FR173S	2	Pre-Installed Rubber		
5"	<b>NEW</b>	FR175S	2	Pre-Installed Rubber		
7"	<b>NEW</b>	FR177S	2	Pre-Installed Rubber		
<b>08-16 F-250 Super Duty 4WD</b>						
4"		FR84S	2	Pre-Installed Rubber		
6"		FR86S	2	Pre-Installed Rubber		
8"		FR88S	2	Pre-Installed Rubber		
<b>99-07 F-250 / F-350 Super Duty 4WD</b>						
4"		FR94S	2	Pre-Installed Rubber		
6"		FR96S	2	Pre-Installed Rubber		
8"		FR98S	2	Pre-Installed Rubber		
<b>66-77 F-250 Highboy 4WD</b>						
4"		FR74S	2	Pre-Installed Rubber		FLFR74
<b>79-98 F-350 4WD</b>						
1"		FR52S	2	Pre-Installed Rubber		FLFR52
3"		FR54S	2	Pre-Installed Rubber		FLFR54
5"		FR56S	2	Pre-Installed Rubber		FLFR56
<b>83-97 Ranger 4WD, 2WD</b>						
4"	Q2	FR34S	2	Pre-Installed Rubber		FLFR34
6"	Q2	FR36S	2	Pre-Installed Rubber		FLFR36
KIT NOTES: Q2. Factory Block can be Removed to Reduce Lift 2-3" Depending on Factory Block Size.						
<b>83-90 Bronco II 4WD, 2WD</b>						
4"		FR34S	2	Pre-Installed Rubber		FLFR34
6"		FR36S	2	Pre-Installed Rubber		FLFR36
<b>JEEP</b>						
<b>87-96 Wrangler YJ</b>						
2-2.5"		YJ20RS	2	SE4YJ	1	FLYJ20R
3.5"-4"		YJ40RS	2	SE4YJ	1	FLYJ40R
<b>87-96 Wrangler YJ Rock Ready® Double Military Wrap</b>						
2.5"		YJ25RS	2	SE45YJ	1	
4"		YJ45RS	2	SE45YJ	1	
<b>76-86 CJ &amp; Scrambler</b>						
2-2.5"		J20RS	2	SE45J	1	FLJ20R
3.5"-4"		J40RS	2	SE45J	1	FLJ40R
<b>55-75 CJ</b>						
2-2.5"		J32RS	2	SE34J	1	FLJ32R
3.5"-4"		J34RS	2	SE34J	1	FLJ34R
<b>84-01 Cherokee XJ 4WD, 2WD</b>						
2.5"		JC25RS	2	Pre-Installed Rubber		FLJC25R
5.5"	Q5	JC55RS	2	Pre-Installed Rubber		
7.5"	Q5	JC75RS	2	Pre-Installed Rubber		
KIT NOTES: Q5. Skyjacker® Shackles # SH130 are REQUIRED.						
<b>84-91 Grand Wagoneer 4WD Full-Size</b>						
3-4"		JP40RS	2	Pre-Installed Rubber		FLJP40R
<b>76-83 Cherokee, Wagoneer 4WD Full-Size</b>						
4"		JP40RS	2	Pre-Installed Rubber		FLJP40R
<b>74-88 J10, J20 Pickup 4WD Full-Size</b>						
4"	Q8	JP40RS	2	Pre-Installed Rubber		FLJP40R
KIT NOTES: Q8. 74-75 Models MUST have 131" Wheel Base & 7,200 lb. GVWR or More for Rear Springs to Fit.						
<b>TOYOTA</b>						
<b>07-18 Tundra 4WD</b>						
4-4.5"		TUR47S	2	Pre-Installed Rubber		

# REAR SOFTRIDE® LEAF SPRINGS

FRONT LIFT	NOTES	SINGLE SPRING	QTY.	BUSHING SETS TO FIT 2 SINGLE SPRINGS	QTY.	FITTED LEAFS FOR PAIR
<b>05-18 Tacoma 4WD</b>						
1.5"-2"		TCR515S	2	Pre-Installed Rubber		
<b>98-04 Tacoma 4WD, 2WD</b>						
2.5"		TCR25S	2	Pre-Installed Rubber		
<b>95-97 Tacoma 4WD, 2WD</b>						
3.5"		TR39S	2	SE39T	1	FLTR49
<b>89-95 Pickup 4WD</b>						
4"		TR49S	2	SE39T	1	FLTR49
<b>79-88 Pickup 4WD</b>						
2"		TR20S	2	SE35T	1	FLTR20
4"		TR40S	2	SE35T	1	FLTR40
6"		TR60S	2	SE35T	1	FLTR60
<b>85-89 4Runner 4WD</b>						
0-1"		TR20S	2	SE35T	1	FLTR20
<b>85-89 4Runner 4WD</b>						
2-3"		TR40S	2	SE35T	1	FLTR40
4-5"		TR60S	2	SE35T	1	FLTR60
<b>64-80 FJ40 LandCruiser 4WD</b>						
2.5"		L20RS	2	SE40L	1	FLL20R
3.5"		L40RS	2	SE40L	1	FLL40R
<b>INTERNATIONAL</b>						
<b>72-82 Scout II, Terra, Traveler 4WD</b>						
2"		S20RS	2	SE40S	1	FLS20R
4"		S40RS	2	SE40S	1	FLS40R
<b>JEEP SOFTRIDE® SERIES</b>						
<b>87-96 Wrangler YJ</b>						
2-2.5"		YJ20RSB	2	SE4YJ	1	FLYJ20R
3.5"-4"		YJ40RSB	2	SE4YJ	1	FLYJ40R
<b>76-86 CJ &amp; Scrambler</b>						
2-2.5"		J20RSB	2	SE45J	1	FLJ20R
3.5"-4"		J40RSB	2	SE45J	1	FLJ40R
<b>84-01 Cherokee XJ 4WD, 2WD</b>						
2.5"		JC25RSB	2	Pre-Installed Rubber		FLJC25R
5.5"	Q5	JC55RSB	2	Pre-Installed Rubber		

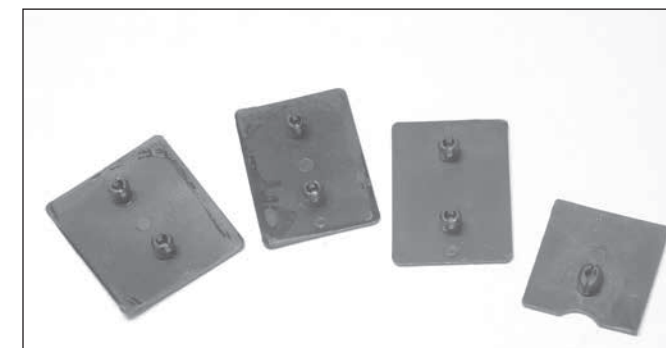

<b>LEAF SPRING ACCESSORIES</b>		
<b>REPLACEMENT TEFLON® WEAR PADS - EACH</b>		
Fits LEAF SPRING MODELS with 2", 2.5 or 3" Wide Leaf Springs.		
Spring Width	Button Style	Part #
2"	Single	IN200C
2.5"	Single	IN212C
2.5"	Double	IN212D
2.5"	Off-Center	IN212
3"	Double	IN300D

# STEERING COMPONENTS

PITMAN ARMS, STEERING ARMS & DRAG LINKS						
LIFT HEIGHT	NOTES	PITMAN ARM		STEERING		OFFSET & ADJUSTABLE DRAGLINK
		DROP	EXTREME DROP	ARM	BLOCK	
<b>CHEVROLET / GMC</b>						
<b>77-91 K10, K20 &amp; K30 Pickup 4WD</b>						
<b>67-91 K30 Pickup 4WD - For Open Knuckles Only</b>						
2.5-4"		CA50			SB60	
6"						GMDL4
<b>67-87 K10, K20 Pickup 4WD - Must Have 3-Bolt Steering Knuckle</b>						
2.5"		CA50				
4-6"				CA100		GMDL4
8"				CA150		
<b>67-91 K5 Blazer, Jimmy, K10, K20 Pickup &amp; Suburban - Must Have 3-Bolt Steering Knuckle</b>						
2.5"		CA50				
4-6"				CA100		GMDL4
8"				CA150		
<b>DODGE</b>						
<b>61-18 1500, 2500 &amp; 3500 Ram Pickup 4WD</b>						
<b>14-18 2500 / 13-18 3500 Ram Pickup 4WD</b>						
4-6"		RA100				
<b>09-12 2500 / 3500 Ram Pickup 4WD</b>						
4-5"		DA309				
<b>03-08 2500 / 3500 Ram Pickup 4WD</b>						
4-5"		DA303				
<b>00-02 2500 &amp; 3500 Ram Pickup 4WD</b>						
3-5"		DA302				
5-8"			DA602			
<b>00-01 1500 Ton Ram Pickup 4WD</b>						
3-5"		DA302				
5-8"			DA602			
<b>94-99 1500, 2500 &amp; 3500 Ram Pickup 4WD</b>						
3-6"		DA300				
6-8"			DA600			
<b>87-93 W250, W350 Pickup 4WD with Cummins Diesel &amp; Power Steering</b>						
4"		DA20			SB60	DL10
6"		DA45			SB60	DL10
<b>78-93 W100, W150 Pickup 4WD Except Cummins Diesel &amp; Power Steering Models</b>						
2"	V10	DA20			SB60	DL10
4"	V10	DA40			SB60	DL10
KIT NOTES: V10. Steering Block for 3500 4x4 Dana 60 Applications Only.						
<b>78-93 W100, W150 Pickup 4WD Must have 3-Bolt Steering Knuckle</b>						
6"	25			DA60	SB60	DL10
KIT NOTES: V10. Steering Block for 3500 4x4 Dana 60 Applications Only.						
<b>72-93 Full Size 4WD To Replace Factory Non-Adjustable Drag Link</b>						
ALL						DL10
<b>72-77 Full Size 4WD Must have 3-Bolt Steering Knuckle &amp; Must Use Adjustable Drag Link # DL10</b>						
8"				DA65		DL10
<b>61-77 Full Size 4WD Must have 3-Bolt Steering Knuckle</b>						
4-6"				DA60		DL10
<b>61-93 Full Size 4WD Dana 60 Axles Open Knuckles Only</b>						
2.5"					SB60	DL10

# STEERING COMPONENTS

PITMAN ARMS, STEERING ARMS & DRAG LINKS						
LIFT HEIGHT	NOTES	PITMAN ARM		STEERING		OFFSET & ADJUSTABLE DRAGLINK
		DROP	EXTREME DROP	ARM	BLOCK	
<b>FORD</b>						
<b>66-18 ALL FORD MODELS</b>						
<b>17-18 F-250, F-350 Super-Duty 4WD</b>						
6-8.5"	V11	FA450				
KIT NOTES: V11. FA450 Pitman arm not to be used on less than 6" of lift for 17-18 Models.						
<b>05-16 F-250, F-350 Super-Duty 4WD</b>						
4-8.5"		FA450				
<b>99-04 F-250, F-350 Super-Duty, 00-05 Excursion 4WD (After March '99)</b>						
4-6"		FA499				
8"			FA699			
<b>99 F-250, F-350 Super-Duty 4WD (Before March '99)</b>						
4-6"		FA400				
8"			FA600			
<b>83-97 Ranger, Bronco II &amp; Explorer 4WD, 2WD with Power Steering</b>						
4-6"		FA400				
6-8"			FA600			
<b>80-96 F-150 &amp; Bronco, 80-98 F-250, F-350 4WD, 2WD with Power Steering</b>						
4-6"		FA400				
6-8"			FA600			
<b>78-79 Bronco 4WD with Power Steering</b>						
4-6"		FA300				
6-9"			FA500			
<b>77.5-79 F-250 4WD with Power Steering (For 5-6" Lifts Combine with # SDL250 Drag Link)</b>						
2-3"		FA325				
<b>77.5-79 F-250, F-350 4WD (For 5-6" Lifts Combine with # FA325 Pitman Arm)</b>						
3-4"						SDL250
<b>76-79 F-100, F-150 4WD with Power Steering</b>						
4-6"	V6	FA300				
6-9"	V6		FA500			
KIT NOTES: V6. Pitman Arm ONLY Fits 76-79 Models with Power Steering. 76-77 Models MUST Change Drag Link & Tie Rod Assembly to "T" Style. Order # FDL70 & # TRA70.						
<b>66-77 Bronco 4WD with Power or Manual Steering</b>						
4-5"	V7	FA307				
KIT NOTES: V7. Pitman Arm Fits Manual & Power Steering. 76-77 Models MUST Change Drag Link & Tie Rod Assembly to "T" Style. Order # FDL67 & # TRA60.						
<b>JEEP</b>						
<b>07-18 Jeep JK 2 &amp; 4 Door 4WD</b>						
<b>07-18 Jeep JK 2 &amp; 4 Door with Power Steering</b>						
4-7"		JA770				
<b>Heavy Duty 1 3/4" O. D. Drag Link</b>						
ALL		JK717DL				
<b>Heavy Duty 1 3/4" O. D. Tie Rod</b>						
ALL		JK717TR				
<b>72-06 JEEP TJ, YJ, CJ</b>						
<b>97-06 Wrangler TJ with Power Steering</b>						
4-6"	V10	JA750				
8-10"	V10	JA500				
KIT NOTES: V10. Designed for Skyjacker Lifts Only.						
<b>97-06 Wrangler TJ Right Hand Steer with Power Steering</b>						
4-6"		JA250				
<b>97-06 Wrangler TJ with Manual Steering</b>						
4-6"		JA850				



# STEERING COMPONENTS

# REAR BLOCKS & U-BOLT KITS

PITMAN ARMS, STEERING ARMS & DRAG LINKS						
LIFT HEIGHT	NOTES	PITMAN ARM		STEERING		OFFSET & ADJUSTABLE DRAGLINK
		DROP	EXTREME DROP	ARM	BLOCK	
<b>87-96 Wrangler YJ with Power Steering</b>						
3.5-4"		JA750				
<b>87-96 Wrangler YJ with Manual Steering</b>						
3.5-4"		JA850				
<b>76-86 CJ &amp; Scrambler with Power Steering</b>						
3.5-4"		JA250				
<b>76-86 CJ &amp; Scrambler with Manual Steering</b>						
3.5-4"		JA150				
<b>72-75 CJ &amp; Scrambler with Power Steering</b>						
2"		JA552				
<b>72-75 JEEP CJ</b>						
<b>72-75 CJ with Manual Steering</b>						
2"		JA652				
<b>72-75 CJ with Manual Steering</b>						
3-4"		JA650				
<b>74-01 JEEP SUV</b>						
<b>84-01 Cherokee XJ, 4WD, 2WD 5.25" Drop Below Factory Arm</b>						
4-8"			JA500			
<b>93-98 Grand Cherokee ZJ, 4WD, 2WD 5.25" Drop Below Factory Arm</b>						
4-8"			JA500			
<b>84-91 Grand Wagoneer Full-Size 4WD with Power Steering</b>						
3.5-4"		JA350				
<b>74-83 Cherokee, Wagoneer Full-Size 4WD with Power Steering</b>						
3.5-4"		JA350				
<b>74-88 J10, J20 Pickup 4WD with Power Steering</b>						
3.5-4"		JA350				
<b>TOYOTA</b>						
<b>79-85 Pickup, 4Runner 4WD</b>						
4-7"	V8					TDL5
KIT NOTE: V8, 7" Lifts REQUIRE the Following: # TDL5 Adjustable Drag Link, # FBL30 & # RBL30 Longer Stainless Steel Brake Lines, Lengthening of Front Driveshaft & Modifying Factory Steering Arm so that Ball is Pointing Out the Top of Arm (Rather than Pointing Down).						
<b>INTERNATIONAL</b>						
<b>72-81 Scout II 4WD</b>						
2-4"	SA40					

## 07-18 Jeep JK

### JK717DL

Heavy Duty 1 3/4" O. D. Drag Link



### JK717TR

Heavy Duty 1 3/4" O. D. Tie Rod



REAR BLOCKS & U-BOLT KITS						
Make/Model	REAR LIFT HEIGHT					
	1 1/4"	2"	3.5"	4.5"	5.5"	
<b>CHEVROLET / GMC</b>						
<b>1500 &amp; 2500 6 Lug Pickup 2WD</b>						
99-06	BUK12562					
<b>1500 &amp; 2500 6 Lug Pickup 4WD</b>						
07-18	BUK12563	BUK2063			BUK5795	
99-06	BUK12563	BUK2063	BUK3564	BUK4565		
88-98	BUK12563	BUK2061	BUK3564	BUK4564	BUK5565	
69-72		BUK2081	BUK3581	BUK4582	BUK5584	
73-87		BUK2087	BUK3588	BUK4589	BUK5589	
<b>2500 8 Lug Pickup 4WD - 00-04 Fits 2500HD</b>						
11-18		BUK2789				
00-10	BUK12581	BUK2082	BUK3584	BUK4584		
88-98		BUK2061		BUK4564		
73-87					BUK5592	
<b>3500 Pickup 4WD Except Crew Cab &amp; Dually</b>						
88-98		BUK2082	BUK3584	BUK4584		
73-87		BUK2082	BUK3584	BUK4584		
<b>3500 Crew Cab Pickup 4WD - Except Dually</b>						
92-98		BUK2082	BUK3584			
73-91		BUK2082	BUK3584			
<b>Blazer, Jimmy, Tahoe, Yukon 4WD</b>						
92-99	BUK12563	BUK2061		BUK4564		
73-91			BUK3588	BUK4589	BUK5589	
69-72		BUK2080				
<b>Suburban 1500 &amp; 2500 6 Lug 4WD</b>						
92-99	BUK12563	BUK2061		BUK4564		
73-91			BUK3588	BUK4589	BUK5589	
<b>Suburban 2500 8 Lug 4WD</b>						
92-99	BUK12563	BUK2063		BUK4564		
73-87		BUK2091	BUK3592	BUK4592	BUK5592	
<b>DODGE</b>						
<b>2500 Pickup</b>						
94-02		BUK2713				
<b>1500 Pickup, Ramcharger / Trailduster</b>						
69-01		BUK2064	BUK3565	BUK4564		
<b>2500 Pickup 4WD Except Diesel</b>						
69-93		BUK2064	BUK3565	BUK4564		



<b>FORD</b>						
<b>F-100, F-150 2WD / 4WD</b>						
04-18		BUK2074DF				

<b>F-100, F-150 4WD</b>						
97-03		BUK2072	BUK3573	BUK4573	BUK5574	
80-96			BUK3572		BUK5574	
66-79			BUK3572		BUK5574	
<b>F-100, F-150 2WD</b>						
80-96		BUK2071	BUK3572	BUK4573	BUK5573	
<b>Bronco</b>						
80-96		BUK2071	BUK3572	BUK4573	BUK5573	
78-79		BUK2071	BUK3572	BUK4573	BUK5573	
66-77		BUK2071	BUK3572	BUK4573	BUK5573	
<b>F-250 4WD / F350</b>						
11-18		BUK2055	BUK3559	BUK4559	BUK5559	
<b>F-250 4WD with Factory 2" Block / 00-05 Excursion</b>						
99-10		BUK2095	BUK3596	BUK4597	BUK5598	
00-05		BUK2095	BUK3596	BUK4597	BUK5598	
<b>F-250 4WD</b>						
80-98		BUK2091	BUK3592	BUK4593	BUK5593	
<b>F-250 2WD</b>						
80-98		BUK2090	BUK3591	BUK4592	BUK5593	
<b>F-350 4WD with Factory 2" Block (No Overload)</b>						
99-10		BUK2095	BUK3596	BUK4597	BUK5598	
<b>F-350 4WD Except Dually</b>						
83-97		BUK2091	BUK3592	BUK4593	BUK5593	
<b>Ranger 4WD</b>						
83-97		BUK2024	BUK3526	BUK4526	BUK5526	
<b>Ranger 2WD</b>						
83-97		BUK2033	BUK3524	BUK4526	BUK5526	
<b>Bronco II</b>						
84-90		BUK2023	BUK3524	BUK4526	BUK5526	
<b>JEEP</b>						
<b>J-10, J20 Pickup, Cherokee / Wagoneer Full-Size 4WD</b>						
74-90		BUK2071	BUK3572	BUK4573	BUK5573	
<b>TOYOTA</b>						
<b>Tundra 2WD / 4WD</b>						
07-18	BUK12592					
<b>Pickup 4WD with 2.5" Wide U-Bolt - Except 89-96 Short Bed Standard Cab</b>						
79-96		BUK2068	BUK3563			
<b>Short Bed Standard Cab Pickup 4WD with 3.25" Wide U-Bolt</b>						
89-96						
<b>4Runner 4WD</b>						
79-86		BUK2068	BUK3563			
<b>LIFT BLOCKS, REAR - PAIR</b>						
Blocks are High Quality Ductile Iron (NOT Gray Iron), Tapered & are 1-Piece Construction with Axle Pins Built-In.						
NOTE: Blocks are Designed for Rear Springs on Top of Rear Axle Applications ONLY.						
Description	LIFT	Part #				
Center Pinned, Flat Block	1.25"	RBF2125				
Center Pinned, 3 Degree	2"	RB220				
Center Pinned, Flat Block	2"	RBF220				
Off-Center Pinned, 5 Degree	3.5"	RB235				
Off-Center Pinned, Flat Block	4.25"	RBF2425				
Off-Center Pinned, 5 Degree	4.5"	RB245				
Off-Center Pinned, Flat Block	5"	RBF2250				
Center Pinned, Flat Block	5"	RBF250				
Off-Center Pinned, 5 Degree	5.5"	RB255				

# U-BOLTS - SINGLE

# NOTES

## U-BOLTS EACH Includes Nylon Insert Lock Nuts

NUT SIZE	I.D. WIDTH	I.D. LENGTH	U-BOLT SHAPE	PART NUMBER
<b>5/16 THREAD SIZE</b>				
5/16	1	1-3/4	ROUND	516X1X134
5/16	1-1/4	1-3/4	ROUND	516X114X134
5/16	1-1/2	2	ROUND	516X112X2
5/16	1-1/2	2-1/4	ROUND	516X112X214
5/16	1-3/4	2-5/8	ROUND	516X134X258
<b>3/8 THREAD SIZE</b>				
3/8	1-7/16	2-3/4	ROUND	38X1716X234
3/8	2-3/4	3	ROUND	38X234X3
3/8	2-3/4	3-1/2	ROUND	38X234X312
3/8	3-1/8	3-1/2	ROUND	38X318X312
3/8	3-3/4	4-1/2	ROUND	38X334X412
<b>1/2 THREAD SIZE</b>				
1/2	2-1/2	4-1/4	ROUND	12X212X414
1/2	2-1/2	5-1/4	ROUND	12X212X514
1/2	2-1/2	6-1/4	ROUND	12X212X614
1/2	2-3/4	6	ROUND	12X234X6
1/2	2-3/4	8-1/2	ROUND	12X234X812
1/2	2-3/4	9-1/2	ROUND	12X234X912
1/2	2-3/4	10-1/2	ROUND	12X234X1012
1/2	3	10-1/2	ROUND	12X3X1012
1/2	3-1/8	6-1/2	ROUND	12X318X612
1/2	3-1/8	8-1/2	ROUND	12X318X812
1/2	3-3/4	9-1/2	ROUND	12X334X912
<b>9/16 THREAD SIZE</b>				
9/16	2-1/4	8-1/2	SQUARE	916X214X812
9/16	2-1/2	7	SQUARE	916X212X7
9/16	2-1/2	8-3/4	SQUARE	916X212X834
9/16	2-1/2	10-1/2	SQUARE	916X212X1012
9/16	2-1/2	12	SQUARE	916X212X12
9/16	2-1/2	13-1/2	SQUARE	916X212X1312
9/16	2-1/2	15-1/2	SQUARE	916X212X1512
9/16	2-1/2	17	SQUARE	916X212X17
9/16	3	7-1/2	ROUND	916X3X712
9/16	3-1/8	8-1/2	SQUARE	916X318X812
9/16	3-1/8	9-1/2	SQUARE	916X318X912
9/16	3-1/8	9-1/2	SEMI-Round	916X318X912FS
9/16	3-1/8	10-1/2	SEMI-Round	916X318X1012FS
9/16	3-1/8	13-1/2	SQUARE	916X318X1312
9/16	3-1/4	7-1/2	ROUND	916X314X712
9/16	3-1/4	9-1/2	ROUND	916X314X912
9/16	3-1/4	11-1/2	ROUND	916X314X1112
9/16	3-1/4	13-1/2	ROUND	916X314X1312
9/16	3-1/4	15-1/2	ROUND	916X314X1512
9/16	3-3/4	8-1/4	ROUND	916X334X814
9/16	4	9-1/2	ROUND	916X4X912
9/16	3-5/8	8	ROUND	916X358X8
9/16	3-5/8	12-1/2	ROUND	916X358X1212
9/16	4	13	ROUND	916X4X13
9/16	4	15	ROUND	916X4X15
<b>5/8 THREAD SIZE</b>				
5/8	2-3/4	9	SQUARE	58X234X9
5/8	2-3/4	10-1/2	SQUARE	58X234X1012
5/8	2-3/4	12-1/2	SQUARE	58X234X1212
5/8	2-5/8	14-1/2	SQUARE	58X258X1412
5/8	3	17-1/2	SQUARE	58X3X1712
5/8	3-1/8	7-1/2	ROUND	58X318X712
5/8	3-1/8	9-1/2	ROUND	58X318X912
5/8	3-1/8	11	ROUND	58X318X11
5/8	3-1/8	12-1/2	ROUND	58X318X1212
5/8	3-1/8	13-1/2	SQUARE	58X318X1312

5/8	3-1/8	16-1/2	SQUARE	58X318X1612
5/8	3-1/4	16	SEMI-Round	58X325X16SP
5/8	3-1/4	18	SEMI-Round	58X325X18SP
5/8	3-1/4	20	SEMI-Round	58X325X20SP
5/8	3-3/8	9-1/2	ROUND	58X338X912
5/8	3-3/8	13	ROUND	58X338X13
5/8	3-3/8	14-1/2	ROUND	58X338X1412
5/8	3-3/8	16-1/2	ROUND	58X338X1612
5/8	3-3/8	19	ROUND	58X338X19
5/8	3-1/2	12	ROUND	58x312x12
5/8	3-1/2	14	ROUND	58x312x14
5/8	3-1/2	16	ROUND	58x312x16
5/8	3-1/2	18	ROUND	58x312x18
5/8	3-5/8	9-1/4	ROUND	58X358X914
5/8	4	10	ROUND	58X4X10
5/8	4	12	ROUND	58X4X12
5/8	4	16	ROUND	58X4X16
5/8	4	18	ROUND	58X4X18

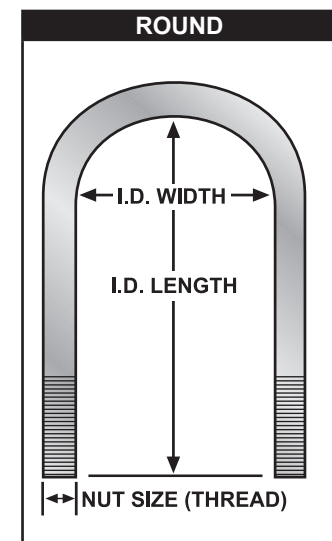
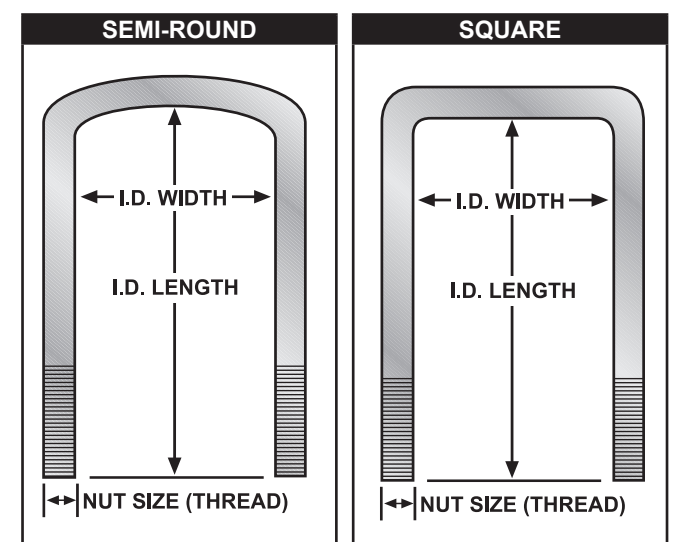

Part # Consists of:  
1 U-Bolt AND  
2 Nylon Insert Lock Nut

## U-BOLT KIT BREAKDOWN ALL U-BOLT KITS INCLUDE NUTS

KIT	SINGLE	NUT	I.D.	I.D.	U-BOLT	
Part #	QTY.	U-BOLT #	SIZE	WIDTH	LENGTH	SHAPE
UCABF	3	58X318X712	5/8	3-1/8	7-1/2	Round
	1	58X358X914	5/8	3-5/8	9-1/4	Round
UCCF	2	58X318X912	5/8	3-1/8	9-1/2	Round
	1	58X4X10	5/8	4	10	Round
	2	58X314CTB	5/8	Stud	3-1/4	Bolt
UC1ASR	4	58X318X912	5/8	3-1/8	9-1/2	Round
UC1BSR	4	58X338X912	5/8	3-3/8	9-1/2	Round
UC1CSR	4	58X234X1012	5/8	2-3/4	10-1/2	Square
UC125BR	4	58X338X11	5/8	3-3/8	11	Round
UC140AR	4	58X318X11	5/8	3-1/8	11	Round
UC140BR	4	58X338X13	5/8	3-3/8	13	Round
UC140CR	4	58X234X1212	5/8	2-3/4	12-1/2	Square
UC168AR	4	58X318X1212	5/8	3-1/8	12-1/2	Round
UC168BR	4	58X338X1412	5/8	3-3/8	14-1/2	Round
UC168CR	4	58X258X1412	5/8	2-5/8	14-1/2	Square
UDBF	2	916X3X712	9/16	3	7-1/2	Round
	1	916X334X814	9/16	3-3/4	8-1/4	Round
	2	916X3CTB	9/16	Stud	3	Bolt
UDCF	2	916X314X712	9/16	3-1/4	7-1/2	Round
	1	916X4X912	9/16	4	9-1/2	Round
	2	916X3CTB	9/16	Stud	3	Bolt
UDWR	4	916X212X7	9/16	2-1/2	7	Square
UDBR	4	916X212X1012	9/16	2-1/2	10-1/2	Square
UDB2R	4	916X212X1312	9/16	2-1/2	13-1/2	Square
UDBBR	4	916X212X1512	9/16	2-1/2	15-1/2	Square
UDB3R	4	916X212X17	9/16	2-1/2	17	Square
UDB6R	4	58X318X1612	5/8	3-1/8	16-1/2	Square
U3WR	4	12X234X812	1/2	2-3/4	8-1/2	Round
U3B2R	4	12X234X1012	1/2	2-3/4	10-1/2	Round
U3B4R	4	12X338X712	1/2	3-3/8	7-1/2	Round
U4WR	4	12X3X1012	1/2	3	10-1/2	Round
U5WWR	4	916X314X712	9/16	3-1/4	7-1/2	Round
U5WR	4	916X314X912	9/16	3-1/4	9-1/2	Round
U5B2R	4	916X314X1112	9/16	3-1/4	11-1/2	Round
U5B3R	4	916X314X1312	9/16	3-1/4	13-1/2	Round
U5B5R	4	916X314X1512	9/16	3-1/4	15-1/2	Round
U5B7R	4	916X318X1312	9/16	3-1/4	13-1/2	Square
U5B8R	4	916X4X15	9/16	4	15	Round
UFF	4	916X318X912	9/16	3-1/8	9-1/2	Square
U9FF	4	916X318X912	9/16	3-1/8	9-1/2	Semi-Round
U7B1R	4	58X338X11	5/8	3-3/8	11	Round
U7B2R	4	58X338X13	5/8	3-3/8	13	Round
U7B3R	4	58X338X1412	5/8	3-3/8	14-1/2	Round
U7B4R	4	58X338X1612	5/8	3-3/8	16-1/2	Round
U9B5R	4	58X3X1712	5/8	3	17-1/2	Square
U9B6R	4	58X312X12	5/8	3-1/2	12	Round

U9B7R	4	58X312X14	5/8	3-1/2	14	Round
U9B8R	4	58X312X16	5/8	3-1/2	16	Round
U9B9R	4	58X312X18	5/8	3-1/2	18	Round
U16FUR	4	58X325X16	5/8	3-1/4	16	Semi-Round
U18FUR	4	58X325X18	5/8	3-1/4	18	Semi-Round
U20FUR	4	58X325X20	5/8	3-1/4	20	Semi-Round
UJPF	2	916X3X712	9/16	3	7-1/2	Round
	2	916X334X814	9/16	3-3/4	8-1/4	Round
UJ3R	4	12X234X6	1/2	2-3/4	6	Round
UJ4R	4	12X212X614	1/2	2-1/2	6-1/4	Round
UTF	4	916X214X812	9/16	2-1/4	8-1/2	Square
UTWR	4	916X212X7	9/16	2-1/2	7	Square
UTBR	4	916X212X1012	9/16	2-1/2	10-1/2	Square

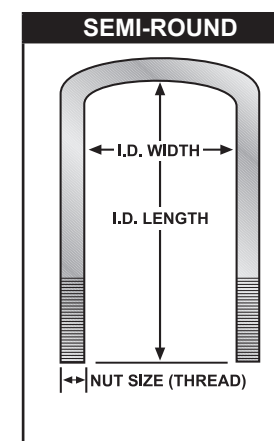
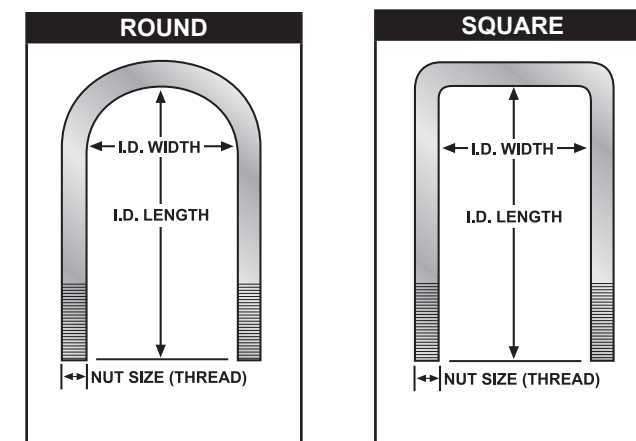

# SKYJACKER® WHEEL & TIRE SPECIFICATIONS

Vehicle		Lift	Maximum Tire			Wheel	
Year	Model		Height	Width	Diameter	Width	Back Space
<b>Chevrolet / GM / GMC</b>							
07-18	K1500, Avalanche, Tahoe, SUV, Etc. (Coil-Over Assembly) <sup>1,2,3</sup>	2"	33"	11.5"	17-20"	8"	OEM
		4"	33"	12.5"	17-18"	8"	OEM
					20"	8"	5.75"
		6"	35"	12.5"	17-18"	8-9"	5.5-5.75"
00-06	Cadillac Escalade, ESV, EXT <sup>1,3,4</sup>	3"	33"	11.5"	16-20"	8-9"	4.5"-OEM
15-18	Colorado / Canyon 4WD	2"	32"	10"	16-18"		OEM
04-13	Colorado / Canyon 4WD <sup>1,2</sup>	4"	33"	11.5"	17-20"	8"	4.75"
00-06	Tahoe / Yukon / Suburban 4WD <sup>1,2,4</sup>	3"	33"	11.5"	16-20"	8-9"	4.5"-OEM
		6"	35"	12.5"	16-18"	8-9"	4.5"
00-06	Denali / Yukon XL 4WD <sup>2,4</sup>	3"	33"	11.5"	16-20"	8-9"	4.5"-OEM
					20"	8-9"	4.5-5.5"
02-06	Avalanche 4WD <sup>1,2,4</sup>	3"	33"	11.5"	16-20"	8-9"	4.5"-OEM
		6"	35"	12.5"	16-18"	8-9"	4.5"
02-08	Hummer H2 4WD	5.5"	38"	12.5"	17-20"	9"	4.5"
		2"	34"	12"	17"	8"	OEM
11-18	GM 2500HD / 3500HD 4WD <sup>1</sup>	6"	35"	12.5"	20"	9"	5.5"
		7"	37"	12.5"	17"	8"	5-5.26"
		7"	37"	12.5"	18"	8-9"	5-5.5"
		7"	37"	12.5"	20"	8.5-10"	5-6"
01-10	GM 2500HD / 3500HD 4WD <sup>1,2,3</sup>	3"	33"	11.5"	16-20"	8-9"	4.5"-OEM
		6"	35"	12.5"	16-18"	8-9"	4.5"
01-08	1500HD, 2500 <sup>1</sup>	6"	35"	12.5"	16-18"	8-9"	4.5"
					20"	8-9"	4.5-5.5"
99-06	K1500 IFS 4WD <sup>1,2,3,4</sup>	3"	33"	11.5"	16"	8"	4.5"
		6"	35"	12.5"	16"	8"	4.5"
88-98	Full-Size IFS 4WD <sup>1,2</sup>	2.5"	33"	11.5"	15-20"	8-9"	4.5"-OEM
		6"	35"	12.5"	15-20"	8-9"	4.5"
88-91	Full-Size Blazer, Jimmy, Suburban 4WD <sup>1</sup>	2.5"	33"	12.5"	15-20"	8-10"	3.5" 4"
		4"	35"	12.5"	15-20"	8-10"	3.5" 4"
		6"	37"	12.5"	15-20"	8-10"	3.5" 4"
		8"	39"	12.5"	15-20"	8-10"	3.5" 4"
73-87	Full-Size 4WD <sup>1</sup>	2.5"	33"	12.5"	15-20"	8-10"	3.5" 4"
		4"	35"	12.5"	15-20"	8-10"	3.5" 4"
		6"	37"	12.5"	15-20"	8-10"	3.5" 4"
		8"	39"	12.5"	15-20"	8-10"	3.5" 4"
67-72	Full-Size 4WD	2.5"	34"	12.5"	15-20"	8-10"	3.5" 4"
		4"	36"	12.5"	15-20"	8-10"	3.5" 4"
		6"	38"	12.5"	15-20"	8-10"	3.5" 4"
		8"	40"	12.5"	15-20"	8-10"	3.5" 4"
<b>DODGE</b>							
09-16	Ram Pickup 1500 4WD <sup>3</sup>	4"	35"	12.5"	18-20"	8-10"	5"
		6"	37"	12.5"	18-20"	8-10"	5"
06-08	Ram Pickup 1500 4WD <sup>3</sup>	2"	33"	12.5"	17-20"	8-9"	OEM
		4"	35"	12.5"	18-20"	8-10"	5"
02-05	Ram Pickup 1500 4WD <sup>2</sup>	6"	37"	12.5"	17"	9"	5"
14-18	Ram Pickup 2500 4WD <sup>2</sup>	2"	33"	11.5"	18"	9"	4.5-5"
		4"	35"	12.5"	17-20"	8-9"	4.5"
		6"	37"	12.5"	17-20"	8-9"	4.5"
03-13	Ram Pickup 2500 4WD <sup>2</sup>	3"	34"	12.5"	17-20"	8-10"	4.625"
		5"	37"	12.5"	17-20"	8-10"	4.625"

Vehicle		Lift	Maximum Tire			Wheel	
Year	Model		Height	Width	Diameter	Width	Back Space
13-18	Ram Pickup 3500 4WD <sup>2</sup>	2"	33"	11.5"	18"	9"	4.5-5"
		4"	35"	12.5"	17-20"	8-9"	4.5"
		6"	37"	12.5"	17-20"	8-9"	4.5"
03-12	Ram Pickup 3500 4WD <sup>2</sup>	3"	34"	12.5"	17-20"	8-10"	4.625"
		5"	37"	12.5"	17-20"	8-10"	4.625"
94-01	Ram Pickup 4WD	2"-3"	33"	12.5"	15-20"	8-10"	4.625"
		4"-5"	35"	12.5"	15-20"	8-10"	4.625"
61-93	Full-Size 1500, 2500 4WD	2"	33"	12.5"	15-20"	8-10"	4"
		4"	35"	12.5"	15-20"	8-10"	4"
		6"	37"	12.5"	15-20"	8-10"	4"
<b>FORD F-150, Bronco, Expedition</b>							
09-18	F-150 4WD <sup>2</sup>	2"	33"	12.5"	17-20"	8"	5"
		4.5"	34"	12.5"	20"	9"	5"
		6"	35"	12.5"	20"	9"	5"
04-08	F-150 4WD, 2WD <sup>2,3,4</sup>	2"-3"	33"	11.5"	17-20"	8-9"	4.5"-OEM
04-08	F-150 4WD, 2WD <sup>2</sup>	6"	35"	12.5"	17-20"	8-9"	4.5"
97-03	F-150 4WD	6"	35"	12.5"	16-20"	8-9"	4.5"
92-96	F-150, Bronco 4WD, 2WD	2"	32"	12.5"	15-20"	8-10"	4"
		4"	33"	12.5"	15-20"	8-10"	4"
		6"	35"	12.5"	15-20"	8-10"	4"
		8"	37"	12.5"	15-20"	8-10"	4"
87-91	F-150, Bronco 4WD, 2WD	2"	34"	12.5"	15-20"	8-10"	4"
		4"	36"	12.5"	15-20"	8-10"	4"
		6"	38"	12.5"	15-20"	8-10"	4"
		8"	39"	12.5"	15-20"	8-10"	4"
80-86	F-150, Bronco 4WD, 2WD	2"	33"	12.5"	15-20"	8-10"	4"
		4"	35"	12.5"	15-20"	8-10"	4"
		6"	37"	12.5"	15-20"	8-10"	4"
69-79	F-150, 78-79 Bronco 4WD	2"	33"	12.5"	15-20"	8-10"	4"
		4"	35"	12.5"	15-20"	8-10"	4"
		6"	37"	12.5"	15-20"	8-10"	4"
		9"	40"	12.5"	15-20"	8-10"	4"
66-77	Bronco 4WD with Cut-Outs	3"	33"	12.5"	15-20"	8-10"	4"
		5"	35"	12.5"	15-20"	8-10"	4"
		7"	37"	12.5"	15-20"	8-10"	4"
03-08	Expedition 4WD	2"	32"	11.5"	16-20"	8"	3.625"
<b>FORD F-250, F-350</b>							
17-18	F-250, F-350 4WD Super Duty <sup>2</sup>	1"	32"	12.5"	17-20"	9"	5"
		2"	33"	12.5"	17-20"	9"	5"
		4"	35"	12.5"	17-20"	9"	5"
		6"	37"	12.5"	17-20"	9"	5"
		8.5"	38"	12.5"	17-20"	9"	5"
05-16	F-250, F-350 4WD Super Duty <sup>2</sup>	1"	32"	12.5"	17-20"	9"	5"
		2"	33"	12.5"	17-20"	9"	5"
		4"	35"	12.5"	17-20"	9"	5"
		6"	36"	12.5"	17-20"	9"	5"
99-04	F-250, F-350 4WD Super Duty	2"	33"	12.5"	16-20"	8-10"	4.5-5"
		4"	35"	12.5"	16-20"	8-10"	4.5-5"
		6"	36"	12.5"	16-20"	8-10"	4.5-5"
		8"	38"	12.5"	16-20"	8-10"	4.5-5"
92-98	F-350 4WD Mono Beam	2"	34"	12.5"	16.5-20"	9.75"	4.625"
		4"	36"	12.5"	16.5-20"	9.75"	4.625"
		6"	38"	12.5"	16.5-20"	9.75"	4.625"

Vehicle		Lift	Maximum Tire			Wheel	
Year	Model		Height	Width	Diameter	Width	Back Space
86-91	F-350 4WD Mono Beam	2"	36"	12.5"	16.5-20"	9.75"	4.625"
		4"	38"	12.5"	16.5-20"	9.75"	4.625"
		6"	40"	12.5"	16.5-20"	9.75"	4.625"
92-98	F-250 4WD Twin I Beam	2"	33"	12.5"	16.5-20"	9.75"	4.625"
		4"	35"	12.5"	16.5-20"	9.75"	4.625"
		6"	37"	12.5"	16.5-20"	9.75"	4.625"
80-91	F-250, F-350 4WD Twin I Beam	2"	33"	12.5"	16.5-20"	9.75"	4.625"
		4"	35"	12.5"	16.5-20"	9.75"	4.625"
		6"	37"	12.5"	16.5-20"	9.75"	4.625"
92-96	F-250, F-350 2WD	2"	32"	12.5"	16-20"	8"	3.75"
		4"	34"	12.5"	16-20"	8"	3.75"
		6"	36"	12.5"	16-20"	8"	3.75"
78-79	F-250 Low Boy 4WD	2"	35"	12.5"	16.5-20"	9.75"	3.75"
		4"	37"	12.5"	16.5-20"	9.75"	3.75"
		6"	40"	12.5"	16.5-20"	9.75"	3.75"
66-77	F-250 High Boy 4WD	2"	38"	12.5"	16.5-20"	9.75"	3.75"
		4"	40"	12.5"	16.5-20"	9.75"	3.75"
<b>FORD Ranger, Bronco II, Explorer, Navajo</b>							
93-97	Ranger 4WD	2"	32"	12.5"	15-20"	8"	4"
		4"	33"	12.5"	15-20"	8"	4"
		6"	34"	12.5"	15-20"	8"	4"
		8"	36"	12.5"	15-20"	8"	4"
90-94	Explorer, Navajo 4WD	2"	31"	12.5"	15-20"	8"	4"
83-92	Ranger, Bronco II 4WD	2"	28"	12.5"	15-20"	8"	4"
		4"	30"	12.5"	15-20"	8"	4"
		6"	32"	12.5"	15-20"	8"	4"
<b>HONDA</b>							
06-12	Ridgeline 4WD <sup>2</sup>	2"	30"	10.5"	17-20"	8"	5"
72-82	Scout II 4WD	2"	31"	12.5"	15-20"	8"	3.75"
72-82	Scout II 4WD	4"	33"	12.5"	15-20"	8"	3.75"
<b>ISUZU</b>							
05-08	Isuzu i-Series	4"	33"	11.5"	17-20"	8"	4.75"
<b>JEEP</b>							
07-18	Wrangler JK 2 Door & 4 Door <sup>1,2</sup>	2"	33"	12.5"	16-20"	8"	4.5"
		2.5-3.5"	34"	12.5"	16-20"	8"	4.5"
		4-5"	35"	12.5"	16-20"	8"	4.5"
04-06	Wrangler Unlimited, Rubicon	6-7"	37"	12.5"	16-20"	8"	4.5"
		2"	32"	11.5"	15-20"	8"	3.75"
		4"	34"	12.5"	15-20"	8"	3.75"
97-03	Wrangler TJ	6"	35"	12.5"	15-20"	10"	3.75"
		8"	37"	12.5"	15-20"	10"	3.75"
		10"	38"	12.5"	15-20"	10"	3.75"
		2"	31"	10.5"	15-20"	8"	3.75"
87-96	Wrangler YJ	4"	33"	12.5"	15-20"	8"	3.75"
		6"	35"	12.5"	15-20"	8"	3.75"
		2"	31"	12.5"	15-20"	8"	3.75"
55-86	CJ & Scrambler	4"	33"	12.5"	15-20"	10"	3.75"
05-12	Grand Cherokee WK 4WD, 2WD <sup>2</sup>	2"	30.5"	9.5"	17-20"	8"	OEM
99-04	Grand Cherokee WJ 4WD	2"	31"	10.5"	16-20"	8"	3.75-4.5"

Vehicle		Lift	Maximum Tire			Wheel	
Year	Model		Height	Width	Diameter	Width	Back Space
93-98	Grand Cherokee ZJ 4WD, 2WD	3"	31"	10.5"	15-20"	8"	3.75-4.5"
08-12	Liberty 4WD, 2WD	2.5"	30.5"	10"	16-20"	8-9"	OEM
02-07	Liberty 4WD, 2WD <sup>1</sup>	2.5"	30.5"	10"	16-20"	8-9"	OEM
84-01	Cherokee XJ 4WD, 2WD	2"	30"	9.5"	15-20"	7-8"	3.75"
		3"	31"	10.5"	15-20"	8"	3.75"
		6"	33"	12.5"	15-20"	8"	3.75"
06-10	Jeep Commander XK <sup>2</sup>	2"	30.5"	9.5"	17-20"	8	