

**IN-DASH INSTALLATION KIT
FOR SELECT 1992-UP GEO, INFINITI,
NISSAN AND TOYOTA VEHICLES**

VEHICLE APPLICATIONS/TABLE OF CONTENTS:

Kit/Radio Assembl
Wiring Codes
Installation Instructions:

GEO

1992-94 Metro
1993-UP Prizm

INFINITI

1997-UP QX4 Sport Utility

NISSAN

1993-UP Altima
1996-UP Pathfinder
1995-UP Sentra
1995-UP 200SX

SUZUKI

1992-94 Swift

TOYOTA

1993-UP Corolla

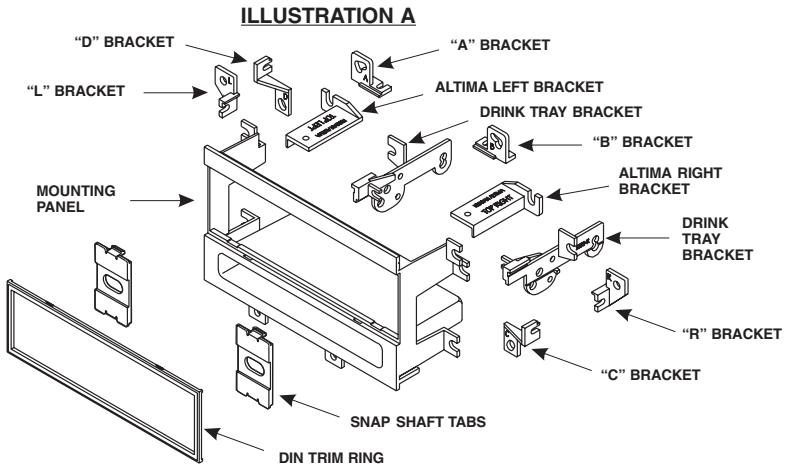

PRELIMINARY PARTS LIST

Parts List:

- Mounting Panel
- Snap Shaft Tabs
- Hardware
- DIN Trim Ring
- Brackets
- Instructions

CAUTION:

Disconnect your vehicle's negative battery cable before removing the radio/proceeding with installation.

NOTES:

- See your vehicle's instructions for any special tools your installation might require.
- Read all instructions accompanying your car stereo/cassette player for proper wiring and mounting instructions.

ASSEMBLING THE KIT

REMOVING THE TABS:

This kit features break-away mounting tabs for all applications. Tabs that will not be used in a particular installation need to be cut off. Use the shaded brackets and tabs.

ILLUSTRATION B

Use pliers to break away, or side cutters (wire cutters) to cut the unnecessary brackets off.

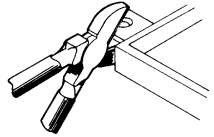

ATTACHING THE BRACKET(S):

Some installations require that you attach specific bracket(s). Using the supplied cinch studs and nuts, secure the specified cinch stud and nuts, secure the specified cinch bracket to the specified slot(s) on the back of the mounting panel (see Illustration C). Then carefully break or cut off the unused brackets as required. Then assemble the radio and the mounting panel as shown in Illustration E, and secure the kit to your dash using the supplied screws. Reassemble your dash, and attach the radio's front panel and controls.

ILLUSTRATION C

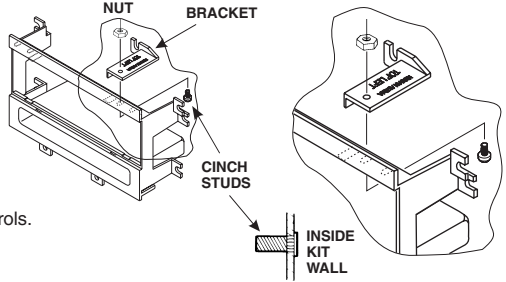

CUP HOLDER BRACKETS:

1. Align the drink tray brackets with the corresponding mounting bosses on the lower back of the kit (see Illustration D) and secure with enclosed screws. **(NOTE: DO NOT OVERTIGHTEN!! This will strip the mounting bosses.)**
2. Remove the factory drink tray from the factory radio assembly and fasten to the kit drink tray brackets using the factory screws/alignment pins.

ILLUSTRATION D

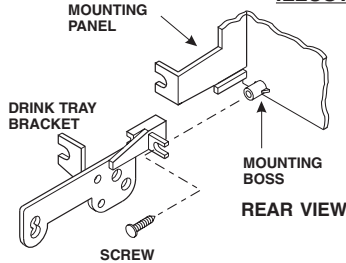

MOUNTING THE RADIO

SHAFT MOUNT RADIOS:

Snap the supplied shaft tabs into place and using the hardware supplied with the radio, secure the radio to the mounting panel as shown.

ILLUSTRATION E

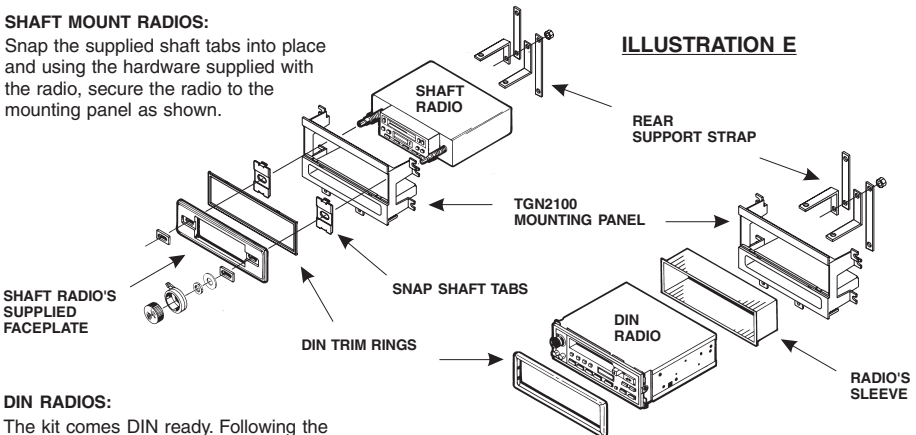

DIN RADIOS:

The kit comes DIN ready. Following the instructions supplied with the radio, secure the radio to the mounting kit.

VARIOUS REAR SUPPORT STRAP SAMPLES

CAUTION:

Rear support is essential to the installation's structural integrity.

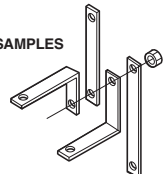

FACTORY WIRE CODES

NOTE: • All wire codes are viewed as looking at the front of the plug with the wires exiting the rear.
 • Use these wiring codes as a guide. Your vehicle might differ.

1982-94 Nissan Vehicles

Power and Front Speakers:

- | | |
|--------------------------------|-----------------------------------|
| 1 = Left Front Negative (LF-) | 6 = Left Front Positive (LF+) |
| 2 = Right Front Negative (RF-) | 7 = Right Front Positive (RF+) |
| 3 = Power Antenna | 8 = Battery/Constant (12V+) |
| 4 = Illumination/Dimmer (12V+) | 9 = Illumination/Pilot |
| 5 = Chassis Ground (12V-) | 10 = 12V Ignition/Switched (12V+) |

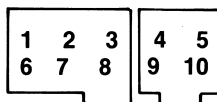

Rear Speakers:

- | | |
|-------------------------------|-------------------------------|
| 1 = Right Rear Positive (RR+) | 4 = Right Rear Negative (RR-) |
| 2 = Left Rear Positive (LR+) | 5 = Left Rear Negative (LR-) |
| 3 = Empty | 6 = Empty |

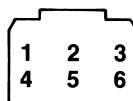

1995-UP Nissan Vehicles

Power and Front Speaker Plug:

- | | |
|----------------------------------|----------------------------------|
| 1 = Chassis Ground (12V-) | 6 = Left Front Negative (LF-) |
| 2 = Variable Illumination/Dimmer | 7 = 12V Ignition/Switched (12V+) |
| 3 = Battery/Constant (12V+) | 8 = Illumination/Dimmer |
| 4 = Power Antenna | 9 = Right Front Positive (RF+) |
| 5 = Right Front Negative (RF-) | 10 = Left Front Positive (LF+) |

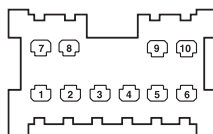

Rear Speaker Plug:

- | | |
|-------------------------------|-------------------------------|
| 1 = Right Rear Negative (RR-) | 4 = Empty |
| 2 = Left Rear Positive (LR+) | 5 = Right Rear Positive (RR+) |
| 3 = Left Rear Negative (LR-) | 6 = Empty |

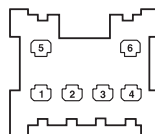

1987-UP Toyota

Power and Front Speaker Plug:

- | | |
|----------------------------------|---------------------------------|
| 1 = Right Front Positive (RF+) | 6 = Left Front Negative (LF-) |
| 2 = Left Front Positive (LF+) | 7 = Chassis Ground (12V-) |
| 3 = 12V Ignition/Switched (12V+) | 8 = Empty |
| 4 = Battery/Constant (12V+) | 9 = Empty |
| 5 = Right Front Negative (RF-) | 10 = Illumination/Dimmer (12V+) |

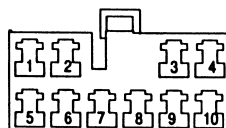

Rear Speaker Plug:

- | | |
|-------------------------------|------------------------------|
| 1 = Right Rear Positive (RR+) | 4 = Empty |
| 2 = Left Rear Positive (LR+) | 5 = Empty |
| 3 = Right Rear Negative (RR-) | 6 = Left Rear Negative (RR-) |

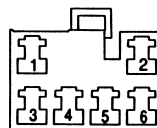

1989-UP Geo/Suzuki Imports

Power and Speaker:

- | | | |
|----------------------------------|--------------------------------|---------------------------------|
| 1 = Left Rear Positive (LR+) | 6 = Right Front Positive (RF+) | 10 = Illumination/Dimmer (12V+) |
| 2 = Right Rear Positive (RR+) | 7 = Left Rear Negative (LR-) | 11 = Battery/Constant (12V+) |
| 3 = Ground return from Dimmer | 8 = Right Rear Negative (RR-) | 12 = Left Front Negative (LF-) |
| 4 = 12V Ignition/Switched (12V+) | 9 = Chassis Ground (12V-) | 13 = Right Front Negative (RF-) |
| 5 = Left Front Positive (LF+) | | |

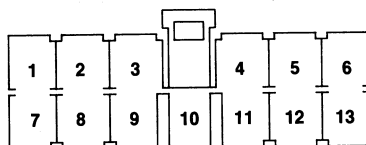

INSTALLATION INSTRUCTIONS

1992-94 Geo Metro 1992-94 Suzuki Swift

RADIO REMOVAL:

1. Carefully pull off the heater control knob tips.
2. Extract (1) screw from above the heater controls.
3. Extract (2) screws from above the radio.
4. Using a panel removal tool, carefully pry out on the top half of the trim bezel, lift up to release the bottom half, and unplug switches to remove.
5. Extract (4) screws holding radio and (1) screw holding

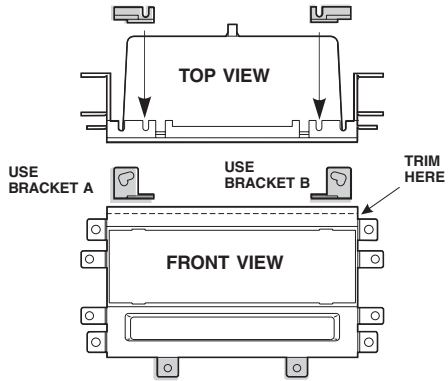

USE THE SHADED MOUNTING TABS AND THE INDICATED BRACKETS. CUT OFF THE REMAINING TABS AND DISCARD.

1993-UP Geo Prizm

RADIO REMOVAL:

1. Using a panel removal tool, carefully pry outward on radio/console trim bezel to release. Unplug all switches and lighter assembly to remove.
2. Extract (4) screws securing radio in the dash, unplug and remove.

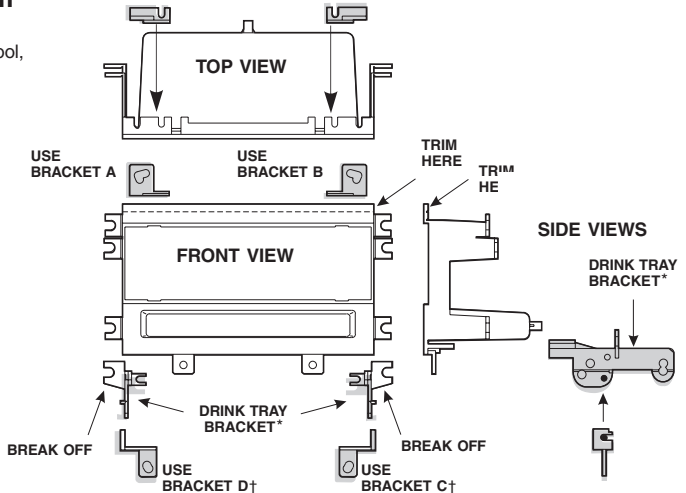

†Attach brackets C & D to cup holder brackets.

*See page 2 for cup holder detail.

USE THE SHADED MOUNTING TABS AND THE INDICATED BRACKETS. CUT OFF THE REMAINING TABS AND DISCARD.

1993-UP Nissan Altima

RADIO REMOVAL:

- Using a panel removal tool, carefully pry up on shifter trim bezel to release and remove.
- Extract (2) screws from the panel below the steering column. Gently pull the panel down to release the clips along the top edge of it and remove the panel.
- Extract (2) screws from just above the radio.
- Extract (4) screws in the shifter area holding the lower rear portion of the radio trim bezel.
- Extract (1) screw at lower left between radio and steering wheel.
- Carefully pull bezel away from console/ dash to remove and use caution above radio where this bezel interlocks with the vent trim.
- Extract 4 screws securing the radio in the dash, unplug and remove.

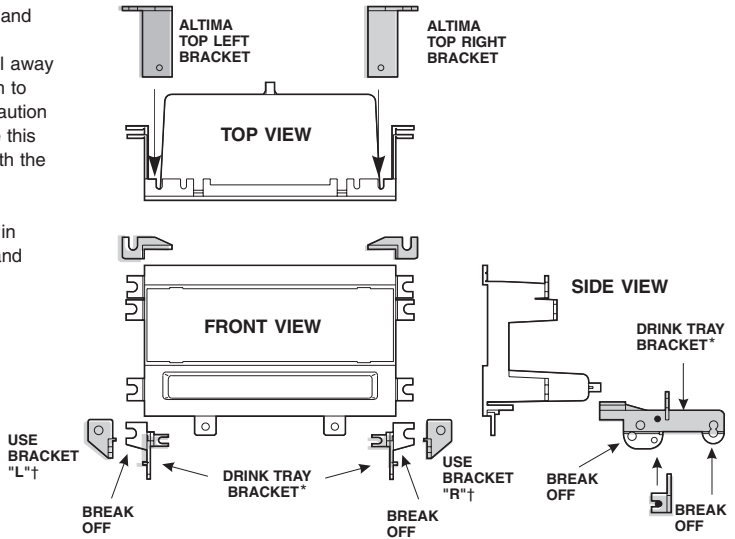

†Attach brackets L & R to cup holder brackets

*See page 2 for cup holder detail

USE THE SHADED MOUNTING TABS AND THE INDICATED BRACKETS. CUT OFF THE REMAINING TABS AND DISCARD.

1996-UP Nissan Pathfinder 1997-UP Infiniti QX4

RADIO REMOVAL:

- Extract (2) screws from the bottom of the radio dash bezel.
- Carefully unsnap radio dash bezel, unplug all switches and remove.
- Extract the (4) screws securing the radio to the dash, unplug connectors and antenna and remove radio.

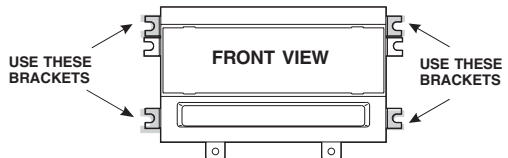

USE THE SHADED MOUNTING TABS AND THE INDICATED BRACKETS. CUT OFF THE REMAINING TABS AND DISCARD.

1995-UP Nissan Sentra 1995-UP Nissan 200SX

RADIO REMOVAL:

1. Using a panel removal tool, carefully unsnap plastic screw cap at top center of the radio trim bezel and remove the screw.
2. Unsnap shifter trim bezel.
3. Extract (4) screws from radio assembly, unplug connectors, antenna lead and remove radio.

*See page 2 for cup holder detail

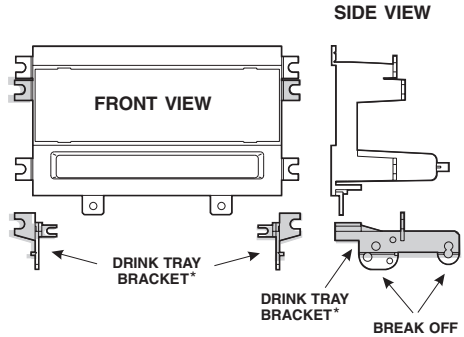

USE THE SHADED MOUNTING TABS AND THE INDICATED BRACKETS. CUT OFF THE REMAINING TABS AND DISCARD.

1993-UP Toyota Corolla

Note: Toyota pocket recommended to fill upper dash location where factory radio was located.

RADIO REMOVAL:

1. Pull outward on the temperature control knobs to remove.
2. Using a panel removal tool carefully pry outward radio trim bezel to release, unplug connectors and remove the bezel.
3. Extract (4) screws securing the radio in the dash, unplug and remove.

*See page 2 for cup holder detail

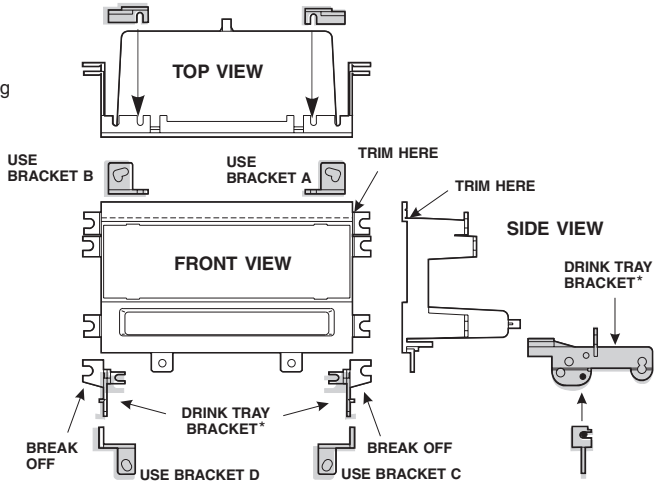

USE THE SHADED MOUNTING TABS AND THE INDICATED BRACKETS. CUT OFF THE REMAINING TABS AND DISCARD.