

RANCHO

PERFORMANCE SUSPENSION & SHOCKS

DYNO MAX

RANCHO



DYNO MAX

Performance Exhaust

WARNING: Suspension systems will enhance the off-road performance of your vehicle. It will handle differently; both on and off-road, from a factory equipped passenger car or truck. Failure to drive this vehicle safely may result in serious injury or death to the driver and passengers. **ALWAYS WEAR** your seat belts, **REDUCE** your speed, and **AVOID** sharp turns and other abrupt maneuvers.

Rancho Suspension recommends that if you put on larger than OE wheels & tires and it causes a significant error in the speed registered by the speedometer and milage on the odometer, that the Speedometer be re-calibrated by a Car Dealer, Speedometer repair shop, or by purchasing an aftermarket speedometer re-calibration device.

PERFORMANCE JEEP PRODUCTS

FALL 2014 EDITION



4-in. SPORT SYSTEM

- Fits up to 37-in. tires
- Front and rear coil springs
- Uses O.E. pitman arm
- Front adjustable track bar included
- Extended length front sway bar end link
- Upgraded front and rear bump stop spacer
- Front extended length brake lines included
- Control arm relocation bracket
- Rear axle track bar bracket
- Rear brake line drop brackets
- Rear sway bar spacers included
- Will not affect the Electronic Stability Control System
- Brackets are high-strength, low-alloy steel
- 100-percent bolt-on system

COMPATIBLE WITH BOTH 2WD AND 4WD

Cross over exhaust pipe RS720003 required for 14-12 JK
Available in black finish only. B designates black finish.

PART NUMBER RS66102B (2/4 Door)

Shocks sold separately:

RS9000™XL	RS999331 - Front	RS999332 - Rear
RS7000®MT	RS7331 - Front	RS7330 - Rear
RS5000™	RS5331 - Front	RS5332 - Rear

DONT FORGET THE STEERING STABILIZER
see page 15



3-3.5-in. PROGRESSIVE SPORT SYSTEM

- Fits up to 35-in. tires
- Front and rear progressive rate coil springs
- Uses O.E. pitman arm
- Front adjustable track bar included
- Extended length front sway bar end link
- Upgraded front and rear bump stop spacer
- Front extended length brake lines included
- Rear brake line drop brackets
- Brackets are high-strength, low-alloy steel
- Will not affect the Electronic Stability Control System
- 100-percent bolt-on system

COMPATIBLE WITH BOTH 2WD AND 4WD

Cross over exhaust pipe RS720003 required for 14-12 JK
Available in black finish only. B designates black finish.

PART NUMBER RS66110B (2/4 Door)

Shocks sold separately:

RS9000™XL	RS999329 - Front	RS999330 - Rear
RS7000®MT	RS7329 - Front	RS7330 - Rear
RS5000™	RS5329 - Front	RS5330 - Rear

3-in. SPORT SYSTEM

- Fits up to 35-in. tires
- Front and rear coil springs
- Uses O.E. pitman arm
- Front adjustable track bar included
- Extended length front sway bar end link
- Upgraded front and rear bump stop spacer
- Front extended length brake lines included
- Rear brake line drop brackets
- Brackets are high-strength, low-alloy steel
- Will not affect the Electronic Stability Control System
- 100-percent bolt-on system

COMPATIBLE WITH BOTH 2WD AND 4WD

Cross over exhaust pipe RS720003 required for 14-12 JK
Available in black finish only. B designates black finish.



PART NUMBER RS66106B (2/4 Door)

Shocks sold separately:

RS9000™XL	RS999329 - Front	RS999330 - Rear
RS7000®MT	RS7329 - Front	RS7330 - Rear
RS5000™	RS5329 - Front	RS5330 - Rear



2-in. SPORT SYSTEM

- Fits up to 33-in. tires
- Front coil springs
- Rear coil spring spacer included
- Upgraded front bump stop spacer
- Uses O.E. pitman arm
- RS5000™ or RS9000™XL Rancho Shocks included
- Rear brake line drop brackets
- Will not affect the Electronic Stability Control System
- 100-percent bolt-on system

COMPATIBLE WITH BOTH 2WD AND 4WD

Available in black finish only. B designates black finish.



PART NUMBER RS66108BR9 (2 Door) - RS9000™XL Shock Absorbers

PART NUMBER RS66108BR5 (2 Door) - RS5000™ Shock Absorbers

PART NUMBER RS66109BR9 (4 Door) - RS9000™XL Shock Absorbers

PART NUMBER RS66109BR5 (4 Door) - RS5000™ Shock Absorbers



UPPER AND LOWER CONTROL ARM SET

- Works with any manufacturers 3 or 4-in. lift kit
- High-articulation front and rear lower short arms
- Adjustable front and rear upper short arm design
- 100-percent bolt-on system

Constructed from high-strength, low-alloy steel

COMPATIBLE WITH BOTH 2WD AND 4WD

Requires removal of control arm relocation bracket when upgrading.
Available in black or red finish. B designates black finish.



PART NUMBER RS66150 OR RS66150B (2/4 Door)

Trimming or modification may be required to provide proper tire clearance. Actual tire size varies between manufacturers. B designates black finish.

JEEP JK



PART NUMBER RS66103 OR RS66103B (2/4 Door)

Shocks sold separately:

RS9000™XL	RS999331 - Front	RS999332 - Rear
RS7000®MT	RS7331 - Front	RS7330 - Rear
RS5000™	RS5331 - Front	RS5332 - Rear

4-in. TRAIL SYSTEM

- Fits up to 37-in. tires
- Front and rear coil springs
- Uses O.E. pitman arm
- Front adjustable track bar included
- Extended length front sway bar end link
- Front and rear lower control arm included
- Upgraded front and rear bump stop spacer
- Front extended length brake lines
- Rear axle track bar bracket
- Rear brake line drop brackets
- Rear sway bar spacers included
- High-articulation front & rear lower short arm design
- Will not affect the Electronic Stability Control System
- Brackets are high-strength, low-alloy steel
- 100-percent bolt-on system

COMPATIBLE WITH BOTH 2WD AND 4WD

Cross over exhaust pipe RS720003 required for 14-12 JK
Available in black or red finish. B designates black finish.



3-in. TRAIL SYSTEM

- Fits up to 35-in. tires
- Front and rear coil springs
- Front adjustable track bar included
- Extended length front sway bar end link
- Upgraded front and rear bump stop spacer
- Front and rear adjustable upper control arms included
- Front extended length brake lines
- Rear track bar bracket
- Rear brake line drop brackets
- Will not affect the Electronic Stability Control System
- Brackets are high-strength, low-alloy steel
- 100-percent bolt-on system

COMPATIBLE WITH BOTH 2WD AND 4WD

Cross over exhaust pipe RS720003 required for 14-12 JK
Available in black or red finish. B designates black finish.

DONT FORGET THE STEERING STABILIZER
see page 15

PART NUMBER RS66107 OR RS66107B (2/4 Door)

Shocks sold separately:

RS9000™XL	RS999329 - Front	RS999330 - Rear
RS7000®MT	RS7329 - Front	RS7330 - Rear
RS5000™	RS5329 - Front	RS5330 - Rear

2014-07

Trimming or modification may be required to provide proper tire clearance. Actual tire size varies between manufacturers. B designates black finish.

JEEP JK WRANGLER 2/4 DOOR

4-in. CRAWLER SHORT ARM SYSTEM

- Fits up to 37-in. tires
- Front and rear coil springs
- New forged pitman arm
- Front axle mounted track bar relocation bracket
- Extended length front sway bar end link
- Upgraded front and rear bump stop spacer
- Front extended length brake lines
- Rear brake line drop brackets
- High-articulation front & rear lower short arm design
- Adjustable front and rear upper short arm design
- Rear axle mounted track bar bracket
- Rear sway bar spacers included
- Will not affect the Electronic Stability Control System
- Brackets are high-strength, low-alloy steel
- 100-percent bolt-on system

COMPATIBLE WITH BOTH 2WD AND 4WD

Cross over exhaust pipe RS720003 required for 14-12 JK
Available in black or red finish. B designates black finish.

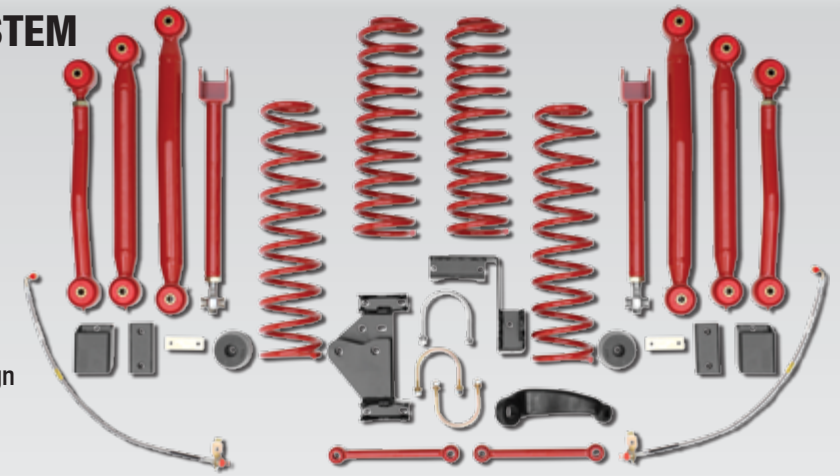

PART NUMBER RS66104 OR RS66104B (2/4 Door)

Shocks sold separately:

RS9000™XL	RS999331 - Front	RS999332 - Rear
RS7000®MT	RS7331 - Front	RS7330 - Rear
RS5000™	RS5331 - Front	RS5332 - Rear
RS7000®MT	High-clearance steering stabilizer RS7401	



UPPER ADJUSTABLE CONTROL ARM UPGRADE KIT

Rancho Adjustable Front and Rear Upper Control Arms for JK Wranglers allow adjustment for caster and pinion angle. Rancho Arms feature rebuildable urethane bushing ends that are greasable, and are built out of 1 3/8-in. OD X 0.134-in. Wall DOM tubing. Front links have .75-in. of adjustment, rear links have 1.50-in. of adjustment. Sold as a front and rear upper set, and are powder-coated red.

- Front Upper Link O.E. = 18.8-in., can adjust from 18.4-in. to 19.1-in.
- Rear Upper Link O.E. = 17.5-in., can adjust from 17.0-in. to 18.6-in.
- Adjustable front and rear upper short arm design
- 100-percent bolt-on system

COMPATIBLE WITH BOTH 2WD AND 4WD

Available in black or red finish. B designates black finish.



PART NUMBER RS66151 OR RS66151B (2/4 Door)





For The Ultimate Off-Road Experience



4-in. CRAWLER LONG ARM SYSTEM

- Fits up to 37-in. tires
- Front and rear coil springs
- Extended length front and rear sway bar end link
- Upgraded front and rear bump stop spacers
- Front and rear extended length brake lines
- High-articulation front and rear long arm design
- Heavy-duty tubular-style front radius arm design
- Adjustable front and rear upper link design
- Rear axle mounted track bar bracket
- Will not affect the Electronic Stability Control System
- No exhaust modifications required for 2011-2007
- Brackets are high-strength, low-alloy steel

COMPATIBLE WITH BOTH 2WD AND 4WD

Transmission Cross Member required and sold separately
 Cross over exhaust pipe RS720003 required for 14-12 JK
 Available in black or red finish. B designates black finish.

PART NUMBER RS66105 OR RS66105B (2/4 Door)

Shocks sold separately:

RS9000™XL	RS999331 - Front	RS999332 - Rear
RS7000™MT	RS7331 - Front	RS7330 - Rear
RS5000™	RS5331 - Front	RS5332 - Rear
Cross Member	RS886101 - 11-07	RS886102 - 14-12
	RS7000™MT High-clearance steering stabilizer	RS7401

TRANSMISSION CROSS MEMBER
PART NO. RS886101 OR RS886102

Not included in system. Must be purchased separately

MODEL	RAISE HEIGHT FRONT	REAR	FRONT SPRINGS	FRONT KIT(S)	REAR SPRINGS	REAR KIT(S)	PRIMARY SUSPENSION SYSTEM	SHOCK ABSORBERS FRONT	REAR
Sport Suspension 2/4 Door, 2/4WD	4-in.	3.5-in.	Inc.	RS720003 (14-12)	Inc.	-	RS66102B	RS999331 ^{XL} RS7331 ^{MT} RS5331 ^{R5}	RS999332 ^{XL} RS7330 ^{MT} RS5332 ^{R5}
Sport Suspension 2/4 Door, 2/4WD	3-in.	2.5-in.	Inc.	RS720003 (14-12)	Inc.	-	RS66106B	RS999329 ^{XL} RS7329 ^{MT} RS5329 ^{R5}	RS999330 ^{XL} RS7330 ^{MT} RS5330 ^{R5}
Sport Suspension 4 Door, 2/4WD	2-in.	.75-in.	Inc.	Inc.	Inc.	Inc.	RS66109BR9	RS9000™XL Shocks Inc.	
Sport Suspension 2 Door, 2/4WD	2-in.	1.75-in.	Inc.	Inc.	Inc.	Inc.	RS66108BR9	RS9000™XL Shocks Inc.	
Sport Suspension 4 Door, 2/4WD	2-in.	.75-in.	Inc.	Inc.	Inc.	Inc.	RS66109BR5	RS5000™ Shocks Inc.	
Sport Suspension 2 Door, 2/4WD	2-in.	1.75-in.	Inc.	Inc.	Inc.	Inc.	RS66108BR5	RS5000™ Shocks Inc.	
Upper and Lower Control Arm Set	3-4-in.	2.5-3.5-in.	-	-	-	-	RS66150 RS66150B	-	-
Trail Suspension 2/4 Door, 2/4WD	4-in.	3.5-in.	Inc.	RS720003 (14-12)	Inc.	-	RS66103 RS66103B	RS999331 ^{XL} RS7331 ^{MT} RS5331 ^{R5}	RS999332 ^{XL} RS7330 ^{MT} RS5332 ^{R5}
Trail Suspension 2/4 Door, 2/4WD	3-in.	2.5-in.	Inc.	RS720003 (14-12)	Inc.	-	RS66107 RS66107B	RS999329 ^{XL} RS7329 ^{MT} RS5329 ^{R5}	RS999330 ^{XL} RS7330 ^{MT} RS5330 ^{R5}
Adjustable Upper Control Arm Upgrade Kit	-	-	-	-	-	-	RS66151 RS66151B	-	-
Crawler Short Arm Suspension 2/4 Door, 2/4WD	4-in.	3.5-in.	Inc.	RS720003 (14-12)	Inc.	-	RS66104 RS66104B	RS999331 ^{XL} RS7331 ^{MT} RS5331 ^{R5}	RS999332 ^{XL} RS7330 ^{MT} RS5332 ^{R5}
Crawler Long Arm Suspension 2/4 Door, 2/4WD	4-in.	3.5-in.	Inc.	RS720003 (14-12)	Inc.	-	RS66105 RS66105B	RS999331 ^{XL} RS7331 ^{MT} RS5331 ^{R5}	RS999332 ^{XL} RS7330 ^{MT} RS5332 ^{R5}

All Suspension Systems are compatible with Rubicon model

MODEL	TRANSMISSION CROSS MEMBER (required)	PRIMARY SUSPENSION SYSTEM
Crawler Long Arm Suspension 2/4 Door, 2/4WD	RS886101 - 2011-07 RS886102 - 2014-12	RS66105 RS66105B

Trimming or modification may be required to provide proper tire clearance. Actual tire size varies between manufacturers. B designates black finish.

JEEP JK WRANGLER 2/4 DOOR

DONT FORGET THE STEERING STABILIZER see page 15

JEEP JK



FRONT COIL SPRING SPACER KIT

- 3/4-in. coil spring spacer kit

PART NUMBER RS70082 (2/4 Door)

Shocks sold separately:

RS9000™XL	RS999326 - Front	RS999328 - Rear
RS7000™MT	RS7326 - Front	RS7328 - Rear
RS5000™	RS5326 - Front	RS5328 - Rear



CONTROL ARM CORRECTION BRACKETS

- Jeep Wrangler JK with 2.5 - 4-in. lift height utilizing factory upper & lower control arms
- Eliminates the need for adjustable control arms or cam bolts for caster correction
- Improves front impact ride quality on expansion joints and ledges
- Reduces brake-dive for improved braking performance
- Durable black powder-coated finish
- Works with any manufacturers lift kit
- Direct bolt-up installation
- One-piece welded design
- Sold in pairs



PART NUMBER RS6250B

B designates black finish.

JEEP JK WRANGLER 2/4 DOOR



EXTENDED LENGTH BRAKE LINES

- Stainless steel braided front & rear Brake Lines are protected w/ a vinyl cover
- Provides a firmer and more responsive braking
- Mounting brackets included where necessary
- Sold in pairs

PART NUMBER - FRONT - RS6247 (24.5-INCH)
REAR - RS6248 (22-INCH)



REAR DIFFERENTIAL GLIDE PLATE

- Mounts to front axle casting
- Protects casting from direct contact
- Works with O.E. and most aftermarket differential covers
- Durable red or black powder-coated finish
- Allows for a much smoother glide over obstacles - forwards and backwards

PART NUMBER - RS6242 OR RS6242B (DANA 44)



7 **2014-07**

JEEP JK



CROSS OVER EXHAUST PIPE KIT

- Clearance is optimized for 2 - 5-in. lifted 14-12 Jeep Wranglers, 3.6L V6 engine
- Prevents contact between the exhaust cross over pipe and front drive shaft
- Allows more drive shaft clearance & suspension down travel than exhaust spacers
- Includes all necessary clamps, hardware, and detailed installation instructions
- Mandrel-bent 409 Stainless steel tubing
- Retains equalized OEM down pipe

PART NUMBER RS720003

2014-12 Jeep Wrangler JK 2/4 Door 3.6L V6 with 2 - 5-in. lift height **DYNAMAX**

PERFORMANCE EXHAUST PART NUMBER 88347

2014-12 Jeep Wrangler JK 2/4 Door 3.6L V6 with 2 - 5-in. lift height



PITMAN ARM

- Reduces drag link angle
- Minimizes bump steer
- Corrects turning radius

PART NUMBER RS7789

2014-07 Jeep Wrangler JK 2/4 Door with 3 - 5-in. Lift Height



FRONT QUICK DISCONNECT SWAY BAR LINKS

- Designed for Wranglers w/ 3 - 4-in. lift height
- Quick release lynch pin design
- Heavy-duty construction
- Allows you to disconnect front sway bar for additional suspension travel

PART NUMBER RS6756B

Non-Rubicon models only

B designates black finish.

JEEP JK WRANGLER 2/4 DOOR



DIFFERENTIAL GLIDE PLATE



- Mounts to front axle casting
- Protects casting from direct contact
- Works with O.E. and most aftermarket differential covers
- Durable red or black powder-coated finish
- Allows for a much smoother glide over obstacles - forwards and backwards

PART NUMBER - FRONT - RS6222 OR RS6222B (DANA 30)
FRONT - RS6212 OR RS6212B (DANA 44)

PART NUMBER - REAR - RS6242 OR RS6242B (DANA 44)



DIFFERENTIAL COVER

- Added axle and internal gear protection
- Manufactured from high-strength nodular iron
- Ribbed external construction for added strength
- Durable red or black powder-coated finish
- Off-set over-sized fill plug for increased fluid capacity and easier/quicker filling

PART NUMBER RS6218 (DANA 30), RS6209 OR RS6209B (DANA 44)

CONTROL ARM SKIDS

- Mounts to front lower control arms (axle end)
- Reduces hang-ups and damage to the factory brackets
- Thick 3/16-in. steel construction
- Durable red or black powder-coated finish
- Bolts-on in minutes

PART NUMBER RS6210 OR RS6210B



OIL PAN PROTECTION



- Protects the oil pan from direct contact
- 1/8-in. steel construction
- Easy installation, installs over O.E. oil pan
- Shields the entire oil pan and maintains drain-hole access
- Durable red powder-coated finish
- **NEW** mounting tab to keep armor in place

PART NUMBER RS6236 (2014-12), RS6208 (2011-07)

9 **2014-07**

JEEP JK



FRONT BUMPER

- 1/4-in. thick steel construction
- Compact design provides maximum ingress clearance
- Accommodates most standard-sized winches
- Rancho Black textured powder coat finish

PART NUMBER RS6220B

FRONT LIGHT BAR / GRILL GUARD

- Rancho Black textured powder coat finish
- 1.75-in. steel tube construction
- Two light tabs for driving/fog lights (lights not included)
- Works with Rancho RS6220B front bumper and most other manufactures front bumper

PART NUMBER RS6230B



WINCH PLATE

- 1/4-in. thick steel plate construction
- Fully integrated Fairlead mount
- Black powder coat finish for long lasting durability
- Designed to work with Rancho RS6220B bumper
- Pre-drilled for popular 12 x 4.5-in. and 9 x 4.5-in. winch bolt patterns

PART NUMBER RS6239B



FOG LIGHT MOUNTING KIT

- Black Zinc finish
- All steel construction
- Allows for reuse of the O.E. fog lights
- Works with Rancho RS6220B bumper

PART NUMBER RS6234B



B designates black finish.

JEEP JK WRANGLER 2/4 DOOR



REAR BUMPER WITH TIRE CARRIER & JACK MOUNT

- NEW swing away design works with rear door to open and close together making access to the cargo area quick and easy
- Rancho Black textured powder coat finish
- 1/4-in. High-strength low-alloy steel construction
- Designed to maximize ground clearance
- Maintains O.E. tow hook connection (tow hook not included)
- Rear vent cover and **CB ANTENNA MOUNT INCLUDED**
- Hi-Lift jack mount with quick release straps and a padlock secure location

PART NUMBER RS6235B





FRONT BUMPER

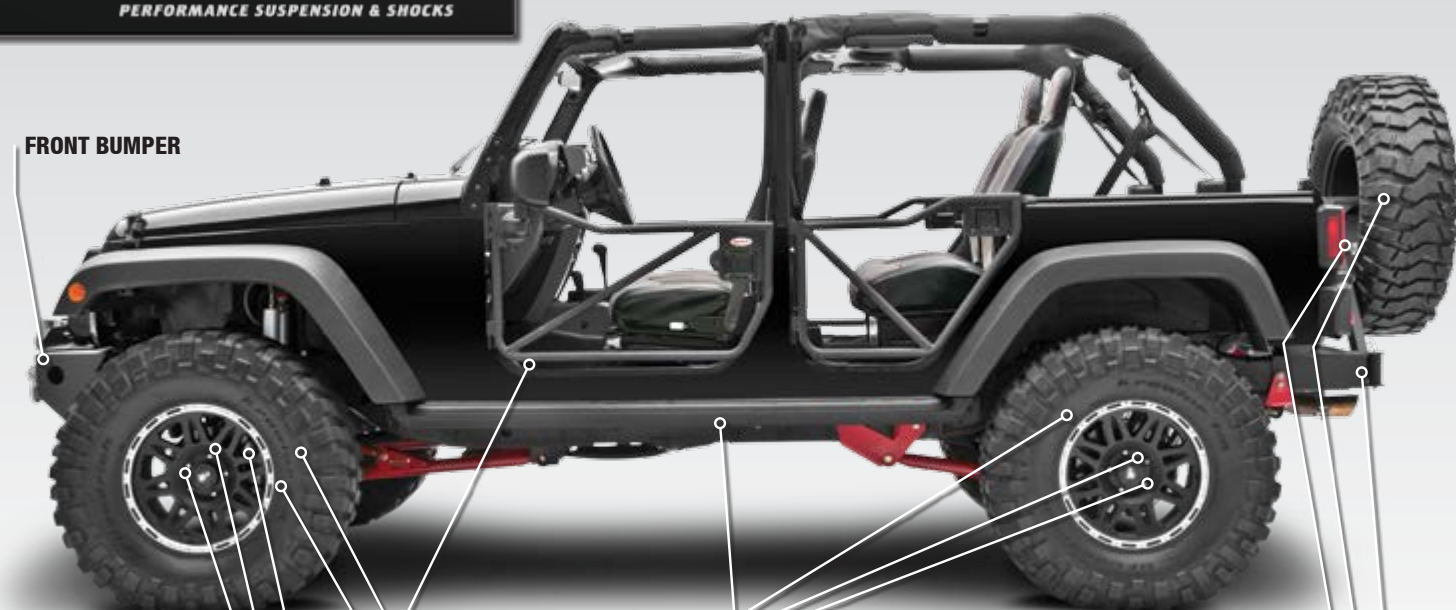

CONTROL ARM SKIDS
FRONT BRAKE LINES
CORRECTION BRACKETS

TUBE DOORS
2 and 4 door (Door skins available)
OIL PAN PROTECTION
FRONT DIFF GLIDE PLATE
Dana 30 and Dana 44

REAR DIFF GLIDE PLATE
Dana 44
DIFF COVER
Dana 30 and Dana 44
REAR BRAKE LINES
DOOR SLIDERS

EAR DOOR COVER PLATE
LED REAR BRAKE LIGHT
REAR BUMPER
With Tire Carrier



REAR BUMPER WITH TIRE CARRIER & JACK MOUNT

- Swing arm design allows access to the cargo area
- Rancho Black textured powder coat finish
- 1/4-in. High-strength low-alloy steel construction
- Designed to maximize ground clearance
- Hi-Lift jack mount

PART NUMBER RS6221B



REAR DOOR COVER PLATE

- One part number fits all applications from 2014-07
- Protects rear decompression vent
- Supersedes part numbers RS6206B and RS6207B
- CB antenna mount included
- Reuses factory bolts and hole locations
- Designed to cover vent when removing spare tire carrier
- Thick steel construction
- Black color looks sharp

PART NUMBER RS6237B



LED REAR BRAKE LIGHT

- Works with Rancho RS6221B, RS6229B & RS6235B bumpers
- Compatible with any 2.25-in diameter hole
- Works with factory wiring, all necessary wires and connectors are included with kit

PART NUMBER RS6238



DOOR SLIDERS

- Added body protection for rocker panels
- Thick-walled 1.5-in. tube construction
- High clearance design follows body contour
- Convenient step to allow for easier entry/exit
- No cutting or drilling installation
- Durable textured black powder-coated finish

PART NUMBER RS6214B (2 Door), RS6215B (4 Door)



TUBE DOORS

- Added visibility for off-road
- Retains factory side mirror (passenger and driver side)
- 1.25-in. tube construction
- Mounts to O.E. door hinge
- O.E. style latch that can be opened from inside or outside
- Durable textured black powder-coated finish

PART NUMBER RS6216B (Front), RS6217B (Rear)

Notes: Tube doors are sold in pairs. Rancho recommends checking local and states laws before installation of this product. Such laws may prohibit installation of this product.

Warning: This product is intended for off-road use only. It is not designed as a safety restraint device. Always wear your seat belts, and avoid sharp turns and other abrupt maneuvers.

2014-07

JEEP JK WRANGLER 2/4 DOOR



RS5000™ STEERING STABILIZERS

Rancho® RS5000™ Steering Stabilizers are a simple and affordable way to enhance a vehicle's performance. Rancho Steering Stabilizers are ideal for off-road driving, towing and street applications. The Steering Stabilizers reduce wheel shimmy, bump steer and vibration as the shock series was engineered for vehicles with oversized tires and wheels. Steering Stabilizers can help reduce on or off-road driver fatigue. Rancho Steering Stabilizers are built from the foundation of the RS5000 series shock absorber – the world's best-selling shock! Covered by a Limited Lifetime Warranty.

YEAR	DESCRIPTION	PART NUMBER	BRACKET KIT
2014-11	Single Steering Stabilizer - Bolts to O.E. mounts - no bracket required	RS5418	-
2010-07	Single Steering Stabilizer - O.E. mounting location	RS5407	RS5510
2014-07	HIGH-CLEARANCE STEERING STABILIZER KIT¹	RS97356	-
2014-07	Dual Steering Stabilizer Setup ²	RS5405 ⁰²	RS64101



RS7000®MT STEERING STABILIZERS

Rancho® RS7000®MT Monotube Steering Stabilizers enhance a vehicle's performance, and are ideal for off roading, towing and street applications. Utilizing Monotube Technology, Rancho Steering Stabilizers help reduce wheel shimmy, bump steer, and vibration while tightening up steering performance by damping the tie rod to the axle. The shock was engineered for Jeeps and trucks running oversized tires and wheels. RS7000MT Steering Stabilizers, built from the foundation of the Rancho RS7000 series shock, can help reduce on- and off-road driver fatigue. The series is covered by a Limited Lifetime Warranty.

YEAR	DESCRIPTION	PART NUMBER	BRACKET KIT
2014-11	Single Steering Stabilizer - Bolts to O.E. mounts - no bracket required	RS7418	-
2010-07	Single Steering Stabilizer - O.E. mounting location	RS7407	RS5510
2014-07	HIGH-CLEARANCE STEERING STABILIZER¹	RS7401	RS64100
2014-07	Dual Steering Stabilizer Setup ²	RS7405 ⁰²	RS64101



¹The installation of this kit requires at least 2-in. tall front bump stop spacers. This prevents the Steering Stabilizer from hitting the bottom of the frame at full jounce travel. ²Requires a 2-in. minimum lift to use, Stabilizer protective boots cannot be used. ⁰²Quantity two required.



RS5000™ SHOCK ABSORBERS

- | | | | |
|-----------------|--|-----------------|--|
| FEATURES | <ul style="list-style-type: none"> • Ten-stage velocity sensitive valving • 5/8-in. (16mm) diameter piston rod* • 1 3/8-in. (35mm) diameter piston* • Protective boot included • Limited Lifetime Warranty* | BENEFITS | <ul style="list-style-type: none"> • Provides tuning specific for each vehicle • Adds strength and durability • Ensures performance in any environment • Protects the shock rod and oil seal • Guarantees your investment |
|-----------------|--|-----------------|--|

VEHICLE HEIGHT	FRONT PART NUMBER	REAR PART NUMBER
0 - 2 in.	RS5326	RS5328
3-in. w/ Rancho RS66106B, RS66107 or RS66107B	RS5329	RS5330
4-in. w/ Rancho RS6507 or RS6507B	RS5329	RS5330
4-in. w/ Rancho RS6509, RS6509B, RS6517, RS6517B, RS66102B, RS66103, RS66103B, RS66104 or RS66104B	RS5331	RS5332



RS7000®MT SHOCK ABSORBERS

- | | | | |
|-----------------|--|-----------------|--|
| FEATURES | <ul style="list-style-type: none"> • 1.97-in. (50mm) body diameter • Monotube design w/ high pressure nitrogen gas charge • Off-road Fluon banded piston • Brushed & Zinc plated with clear coated finish • Ten-stage velocity sensitive valving • 46mm Bore monotube construction • 14mm Hardened steel rod • Black natural rubber bushings • Protective boot included • Limited Lifetime Warranty and 90-Day Free Ride Offer* | BENEFITS | <ul style="list-style-type: none"> • Delivers both performance & appearance • Quicker damping response time • Provides a consistent seal between piston & pressure tube • Premium long lasting finish • Provides tuning specific for each vehicle • Ideal for larger light trucks, SUVs and more • Adds strength & durability • Enhances durability & reduced road harshness • Added protection for the shock rod & oil seal • Consumer protection |
|-----------------|--|-----------------|--|

VEHICLE HEIGHT	FRONT PART NUMBER	REAR PART NUMBER
0 - 2-in.	RS7326	RS7328
3-in.	RS7329	RS7330
4-in.	RS7331	RS7330



RS9000™XL SHOCK ABSORBERS

- | | | | |
|-----------------|---|-----------------|--|
| FEATURES | <ul style="list-style-type: none"> • 2.75-in. (70mm) body diameter* • Large 18mm Nitro Carb rod* • 9-position tuning technology • Nitrogen gas charged • Liquid metallic finish • Polyurethane bushings • Protective boot included • Limited Lifetime Warranty and 90-Day Free Ride Offer* | BENEFITS | <ul style="list-style-type: none"> • Delivers both performance and appearance • Adds strength and durability • Provides 9 different levels of shock performance • Optimizes shock performance • Premium long lasting finish • Enhance shock performance and durability • Added protection for the shock rod and oil seal • Consumer protection |
|-----------------|---|-----------------|--|

VEHICLE HEIGHT	FRONT PART NUMBER	REAR PART NUMBER
0 - 2-in.	RS999326	RS999328
3-in. w/ Rancho RS66106B, RS66107 or RS66107B	RS999329	RS999330
4-in. w/ Rancho RS6507 or RS6507B	RS999329	RS999330
4-in. w/ Rancho RS6509, RS6509B, RS6517, RS6517B, RS66102B, RS66103, RS66103B, RS66104 or RS66104B	RS999331	RS999332



DRONE-FREE PERFORMANCE.™
MUFFLER



**STAINLESS STEEL DRONE-FREE EXHAUST
2/4 DOOR 3.6L, 3.8L V6**

- Stainless steel DynoMax VT® Muffler
- 3-in. outlet, single wall, buffed and polished, 12-in. OAL SS slant cut tip
- 2.5-in. Mandrel bent stainless steel tubing
- Four stainless steel 2.5-in. band clamps

PART NUMBER 38446 (2 Door, 2011-07, shown)
PART NUMBER 38456 (4 Door, 2011-07)
PART NUMBER 38515 (2 Door, 2014-12)
PART NUMBER 38517 (4 Door, 2014-12)

13 HORSEPOWER
12 LB.-FT. TORQUE
IMPROVEMENT

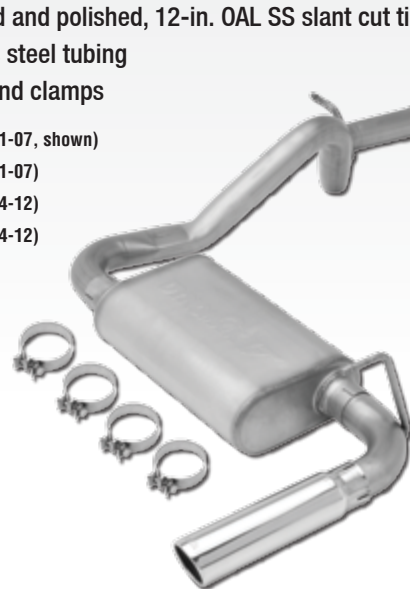

**STAINLESS STEEL EXHAUST
2/4 DOOR 3.6L, 3.8L V6**

- Stainless steel Ultra Flo™ Welded Muffler
- 3-in. outlet, single wall, buffed and polished, 12-in. OAL SS slant cut tip
- 2.5-in. Mandrel bent stainless steel tubing
- Four stainless steel 2.5-in. band clamps

PART NUMBER 39446 (2 Door, 2011-07)
PART NUMBER 39456 (4 Door, 2011-07)
PART NUMBER 39515 (2 Door, 2014-12)
PART NUMBER 39517 (4 Door, 2014-12)

**STAINLESS STEEL EXHAUST
4 DOOR 3.6L, 3.8L V6**

EVOLUTION COMPETITION SYSTEM - FOR OFF-ROAD USE ONLY¹

- Stainless steel Ultra Flo™ Polished Muffler
- 2.5-in. Mandrel bent stainless steel tubing
- Two stainless steel 2.5-in. band clamps

PART NUMBER 39516 (2011-07)
PART NUMBER 39522 (2014-12)

¹ For off-road use only - exhaust exits under vehicle.



STAINLESS STEEL EXHAUST 2/4 DOOR 3.6L, 3.8L V6

- Stainless steel Ultra Flo™ Polished Muffler
- High clearance off-road "Rockcrawler" design
- 3-in. outlet, single wall, buffed and polished, 6-in. OAL SS slant cut tip
- 2.5-in. Mandrel bent stainless steel tubing
- Three stainless steel 2.5-in. band clamps

PART NUMBER 39464 (2 Door, 2011-07 shown)
PART NUMBER 39459 (4 Door, 2011-07)
PART NUMBER 39524 (2 Door, 2014-12)
PART NUMBER 39523 (4 Door, 2014-12)

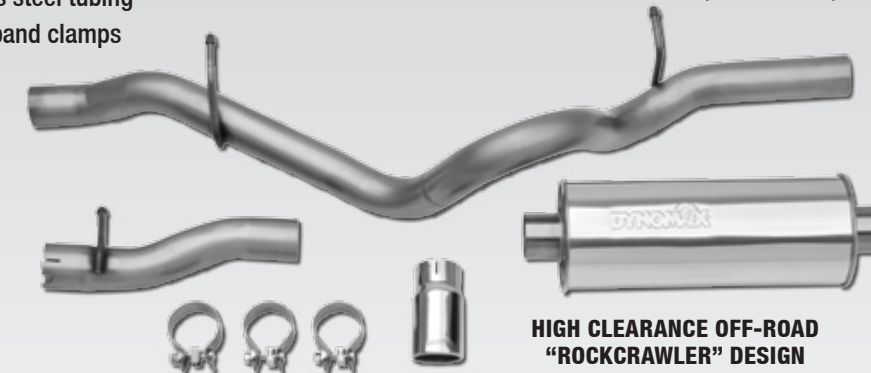

**HIGH CLEARANCE OFF-ROAD
"ROCKCRAWLER" DESIGN**

STAINLESS STEEL DUAL EXHAUST 2/4 DOOR 3.8L V6

- Stainless steel Ultra Flo™ Polished Muffler
- 3-in. outlet, single wall, buffed and polished, 12-in. OAL SS slant cut tips
- 2.5-in. Mandrel bent stainless steel tubing
- Three stainless steel 2.5-in. band clamps

PART NUMBER 39445 (2 Door, 2011-07)
PART NUMBER 39457 (4 Door, 2011-07, shown)

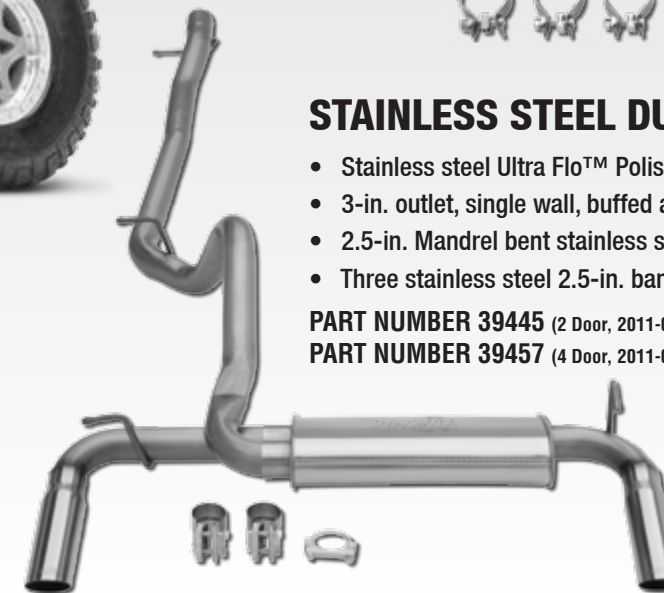

**STAINLESS STEEL DUAL EXHAUST
2/4 DOOR 3.6L, 3.8L V6**

- Stainless steel Super Turbo™ Muffler Assembly
- 3-in. outlet, single wall, buffed and polished, 5.5-in OAL SS slant cut tips
- 2.5-in. Mandrel bent stainless steel tubing

PART NUMBER 39510 (2014-07)



**STAINLESS STEEL DUAL EXHAUST
2/4 DOOR 3.6L, 3.8L V6**

- Super Turbo™ Muffler w/ 304 Stainless steel polished cover
- 4-in. outlet, single wall, buffed and polished, 6-in OAL SS slant cut tips
- 2.5-in. Mandrel bent stainless steel tubing

PART NUMBER 39528 (2014-07)





3.5-in. SHORT ARM SYSTEM

- Fits up to 35-in. tires
- New forged pitman arm
- Front adjustable track bar
- High-articulation link and bushing design
- Rear track bar relocation bracket
- Front and rear heavy-duty springs
- No exhaust modifications required
- Industry leading front sway bar disconnect design
- Transfer case shifter relocation brackets and drop down spacers to allow use of factory drive-shafts
- New brake lines for increased articulation

Available in red finish only. This suspension system was developed using a 33 x 12.5 x R15 tire on a 15 x 8-in. wheel with 3.75 B.S.

PART NUMBER RS6504

Shocks sold separately:

RS9000™XL	RS999255 - Front	RS999256 - Rear
RS7000®MT	RS7255 - Front	RS7256 - Rear
RS5000™	RS5255 - Front	RS5256 - Rear



3.5-in. SPORT SYSTEM

- Fits up to 35-in. tires
- No exhaust modifications required
- Brake line drop brackets
- New lower links
- Front and rear coil springs
- Transfer case shifter relocation brackets and drop down spacers to allow use of factory drive-shafts

Available in red finish only. This suspension system was developed using a 33 x 12.5 x R15 tire on a 15 x 8-in. wheel with 3.75 B.S.

PART NUMBER RS6501

Shocks sold separately:

RS9000™XL	RS999255 - Front	RS999256 - Rear
RS7000®MT	RS7255 - Front	RS7256 - Rear
RS5000™	RS5255 - Front	RS5256 - Rear



2.5-in. SPORT SYSTEM

- Fits up to 33-in. tires
- No exhaust modifications required
- Brake line drop brackets
- New lower links
- Front and rear coil springs
- Transfer case shifter relocation brackets and drop down spacers to allow use of factory drive-shafts

Available in red finish only. This suspension system was developed using a 33 x 12.5 x R15 tire on a 15 x 8-in. wheel with 3.75 B.S.

PART NUMBER RS6503

Shocks sold separately:

RS9000™XL	RS999239 - Front	RS999241 - Rear
RS7000®MT	RS7239 - Front	RS7241 - Rear
RS5000™	RS5239 - Front	RS5241 - Rear

DONT FORGET THE STEERING STABILIZER
see page 25



ADJUSTABLE UPPER CONTROL ARMS

Rancho Adjustable Front and Rear Upper Control Arms for TJ/LJ Wranglers allow adjustment for caster and pinion angle. Rancho Arms feature rebuildable urethane bushing ends that are greasable, and are built out of 1 3/8-in. OD X 0.134-in. Wall DOM tubing. Both links have 1.50-in. of adjustment, minus .50-in. and plus 1.00-in., allowing maximum adjustment. Sold as a front and rear upper set, and are powder-coated red.

- Front Upper Link O.E. = 15.0-in., can adjust from 14.5-in. to 16.0-in.
- Rear Upper Link O.E. = 13.2-in., can adjust from 12.7-in. to 14.2-in.
- Built from 1 3/8-in. OD X 0.134-in. Wall DOM tube
- Gain adjustability and on and off-road performance
- Works with O.E. or Short Arm suspension systems
- Durable red powder-coated finish

PART NUMBER RS66152

FRONT COIL SPRING SPACER KIT

- 3/4-in. coil spring spacer kit

PART NUMBER RS70082



FRONT BUMPER

CONTROL ARM SKIDS
FRONT DIFF GLIDE PLATE
Dana 30 and Dana 44
STEERING BOX SKID PLATE

OIL PAN PROTECTION
4.0L I6 Only
FRONT BRAKE LINES

DIFF COVER
Dana 30 and Dana 44
REAR DOOR COVER PLATE
HI-LIFT JACK MOUNTS

REAR BUMPER
With Tire Carrier
LED REAR BRAKE LIGHT



Trimming or modification may be required to provide proper tire clearance. Actual tire size varies between manufacturers. B designates black finish.

JEEP TJ



REAR BUMPER WITH TIRE CARRIER & JACK MOUNT

- NEW swing away design works with rear door to open and close together making access to the cargo area quick and easy
- Rancho Black textured powder coat finish
- 1/4-in. High-strength low-alloy steel construction
- Designed to maximize ground clearance
- Rear vent cover and **CB ANTENNA MOUNT INCLUDED**
- Hi-Lift jack mount with quick release straps and a padlock secure location
- 1500 lb. Integrated receiver hitch (shown below)



PART NUMBER RS6243B



LED REAR BRAKE LIGHT

- Works with Rancho RS6243B bumper
- Compatible with any 2.25-in diameter hole
- Works with factory wiring, all necessary wires and connectors are included with kit

PART NUMBER RS6238



Shown on Jeep JK

JEEP TJ/LJ WRANGLER



FRONT BUMPER

- 3/16-inch thick high-strength low-alloy steel construction
- Compact design
- Custom CAD layout
- Precision laser cut components
- CNC bent components
- Uses OE mounting points

PART NUMBER RS6226B



TUBE DOORS

- Added visibility for off-road
- Retains factory side mirror (passenger and driver side)
- 1.25-in. tube construction
- Mounts to O.E. door hinge
- O.E. style latch that can be opened from inside or outside
- Durable textured black powder-coated finish

PART NUMBER RS6223B

Notes: Tube doors are sold in pairs. Rancho recommends checking local and states laws before installation of this product. Such laws may prohibit installation of this product.

Warning: This product is intended for off-road use only. It is not designed as a safety restraint device. Always wear your seat belts, and avoid sharp turns and other abrupt maneuvers.



REAR BUMPER WITH TIRE CARRIER & JACK MOUNT

- Swing arm design allows access to the cargo area
- 1.25-in. and 3/16-in. thick high-strength low-alloy steel construction
- 1500 lb. Integrated receiver hitch
- Compact design
- Custom CAD layout
- Precision laser cut components
- CNC bent components
- Uses OE mounting points
- Hi-Lift jack mount

PART NUMBER RS6229B

LED REAR BRAKE LIGHT

- Works with Rancho RS6243B bumper
- Compatible with any 2.25-in diameter hole
- Works with factory wiring, all necessary wires and connectors are included with kit

PART NUMBER RS6238





JEEP TJ



RockGEAR™



FRONT DIFFERENTIAL GLIDE PLATE

- Mounts to front axle casting
- Protects casting from direct contact
- Works with O.E. and most aftermarket differential covers
- Durable red or black powder-coated finish
- Allows for a much smoother glide over obstacles
 - forwards and backwards

PART NUMBER RS6227 OR RS6227B (DANA 30)
RS6228 OR RS6228B (DANA 44)



CONTROL ARM SKIDS

- Mounts to front lower control arms (axle end)
- Reduces hang-ups and damage to the factory brackets
- Thick 3/16-in. steel construction
- Durable red or black powder-coated finish
- Bolts-on in minutes

PART NUMBER RS6210 OR RS6210B

FRONT EXTENDED LENGTH BRAKE LINES

- Stainless steel braided Brake Lines are protected with a vinyl cover
- Provides a firmer and more responsive braking
- Mounting brackets included where necessary
- Sold in pairs

PART NUMBER RS6249 (21.5-INCH)



DIFFERENTIAL COVER

- Added axle and internal gear protection
- Manufactured from high-strength nodular iron
- Ribbed external construction for added strength
- Durable red or black powder-coated finish
- Off-set over-sized fill plug for increased fluid capacity and easier/quicker filling

PART NUMBER RS6218 (DANA 30),
RS6209 OR RS6209B (DANA 44)



OIL PAN PROTECTION

- Protects the oil pan from direct contact
- 1/8-in. steel construction
- Easy installation, installs over O.E. oil pan
- Shields the entire oil pan and maintains drain-hole access
- Durable red powder-coated finish
- NEW mounting tab to keep armor in place

PART NUMBER RS6224 (4.0L I6 only)

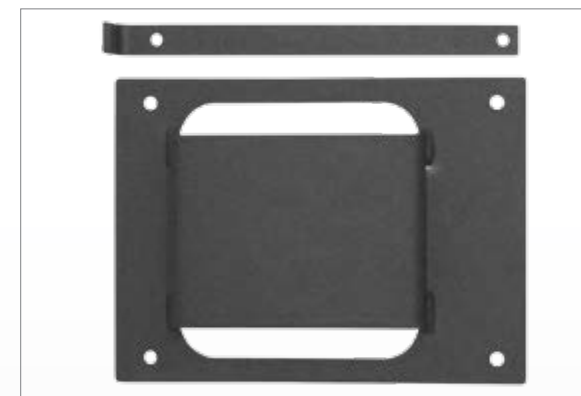

REAR DOOR COVER PLATE

- Protects rear decompression vent
- CB antenna mount included
- Thick steel construction
- Black color looks sharp

PART NUMBER RS6233B

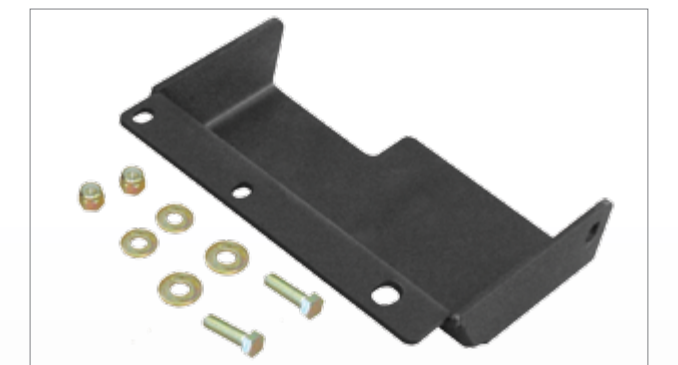

STEERING BOX SKID PLATE

- Thick steel construction
- Black color looks sharp

PART NUMBER RS6225B



2006-97

JEEP TJ/LJ WRANGLER

JEEP TJ



RS5000™ SHOCK ABSORBERS

- FEATURES**
- Ten-stage velocity sensitive valving
 - 5/8-in. (16mm) diameter piston rod*
 - 1 3/8-in. (35mm) diameter piston*
 - Protective boot included
 - Limited Lifetime Warranty*

- BENEFITS**
- Provides tuning specific for each vehicle
 - Adds strength and durability
 - Ensures performance in any environment
 - Protects the shock rod and oil seal
 - Guarantees your investment



VEHICLE HEIGHT	PART NUMBER	
	FRONT	REAR
0-in.	RS5128	RS5240
2.5-in. w/ Rancho RS6503	RS5239	RS5241
3.5-in. w/ Rancho RS6501	RS5255	RS5256
3.5-in. w/ Rancho RS6504	RS5255	RS5256

RS7000®MT SHOCK ABSORBERS

- FEATURES**
- 1.97-in. (50mm) body diameter
 - Monotube design w/ high pressure nitrogen gas charge
 - Off-road Fluon banded piston
 - Brushed & Zinc plated with clear coated finish
 - Ten-stage velocity sensitive valving
 - 46mm Bore monotube construction
 - 14mm Hardened steel rod
 - Black natural rubber bushings
 - Protective boot included
 - Limited Lifetime Warranty and 90-Day Free Ride Offer*

- BENEFITS**
- Delivers both performance & appearance
 - Quicker damping response time
 - Provides a consistent seal between piston & pressure tube
 - Premium long lasting finish
 - Provides tuning specific for each vehicle
 - Ideal for larger light trucks, SUVs and more
 - Adds strength & durability
 - Enhances durability & reduced road harshness
 - Added protection for the shock rod & oil seal
 - Consumer protection



VEHICLE HEIGHT	PART NUMBER	
	FRONT	REAR
0-in.	RS7128	RS7240
2.5-in.	RS7239	RS7241
3.5 - 4-in.	RS7255	RS7256
5 - 6-in.	RS7061	RS7062

RS9000™XL SHOCK ABSORBERS

- FEATURES**
- 2.75-in. (70mm) body diameter*
 - Large 18mm Nitro Carb rod*
 - 9-position tuning technology
 - Nitrogen gas charged
 - Liquid metallic finish
 - Polyurethane bushings
 - Protective boot included
 - Limited Lifetime Warranty and 90-Day Free Ride Offer*

- BENEFITS**
- Delivers both performance and appearance
 - Adds strength and durability
 - Provides 9 different levels of shock performance
 - Optimizes shock performance
 - Premium long lasting finish
 - Enhance shock performance and durability
 - Added protection for the shock rod and oil seal
 - Consumer protection



VEHICLE HEIGHT	PART NUMBER	
	FRONT	REAR
0-in.	RS999128	RS999240
2.5-in. w/ Rancho RS6503	RS999239	RS999241
3.5-in. w/ Rancho RS6501	RS999255	RS999256
3.5-in. w/ Rancho RS6504	RS999255	RS999256



RS5000™ STEERING STABILIZERS

Rancho® RS5000™ Steering Stabilizers are a simple and affordable way to enhance a vehicle's performance. Rancho Steering Stabilizers are ideal for off-road driving, towing and street applications. The Steering Stabilizers reduce wheel shimmy, bump steer and vibration as the shock series was engineered for vehicles with oversized tires and wheels. Steering Stabilizers can help reduce on or off-road driver fatigue. Rancho Steering Stabilizers are built from the foundation of the RS5000 series shock absorber – the world's best-selling shock! Covered by a Limited Lifetime Warranty.

POSITION	DESCRIPTION	PART NUMBER
Front	Single Steering Stabilizer	RS5407
Front	Optional Steering Stabilizer	RS5401 ¹

RS7000®MT STEERING STABILIZERS

Rancho® RS7000®MT Monotube Steering Stabilizers enhance a vehicle's performance, and are ideal for off roading, towing and street applications. Utilizing Monotube Technology, Rancho Steering Stabilizers help reduce wheel shimmy, bump steer, and vibration while tightening up steering performance by damping the tie rod to the axle. The shock was engineered for Jeeps and trucks running oversized tires and wheels. RS7000MT Steering Stabilizers, built from the foundation of the Rancho RS7000 series shock, can help reduce on- and off-road driver fatigue. The series is covered by a Limited Lifetime Warranty.



POSITION	DESCRIPTION	PART NUMBER
Front	Single Steering Stabilizer - Bolts to O.E. mounts - no bracket required - Inc. Rubicon & Unlimited	RS7407

¹ Part No. RS5401. Single large cylinder Steering Stabilizer.

JEEP TJ/LJ WRANGLER



**CONVERTER-BACK EXHAUST
06-04 WRANGLER 4.0L I6**

- Super Turbo™ Muffler
- Patented internal Flow Director Technology w/ Fiberglass Matting
- Large internal flow tubes
- 304 Stainless steel spout on tailpipe
- Aluminized system

PART NUMBER 19403

YEAR	MODEL	PART NUMBER	SYSTEM INFO
2006-04	Wrangler Unlimited 4.0L I6	19403	Single - 2.5-in. system. 2.5-in. tip. Super Turbo™ Muffler
2006-00	Wrangler 4.0L I6 (after 1/24/2000) Exc. Unlimited	19391	Single - 2.25-in. system. 2.5-in. tip. Super Turbo™ Muffler
2000-97	Wrangler 2.5L, 4.0L 4 Cyl., I6 (before 1/24/2000)	17345	Single - 2.25-in. system. 2.5-in. tip. Super Turbo™ Muffler



ULTRA FLO™ WELDED MUFFLER

- Stainless steel construction for lifelong protection
- 100-percent welded design for maximum durability
- Straight-through design ensures unrestricted exhaust flow and reduces back pressure
- Sound level: deep performance tone

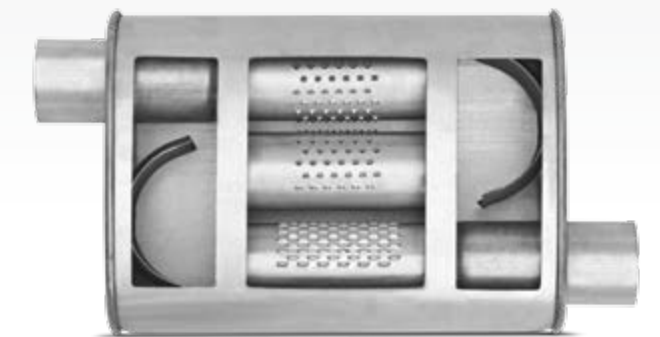

SUPER TURBO™ MUFFLER

- Patented internal flow director technology with fiberglass matting
- Large internal flow tubes improve exhaust flow
- 1-3/4-in. to 3-in. in/outlet configurations
- Sound level: mellow performance tone



YEAR	MODEL	DYNOMAX EXHAUST PART NUMBER	ULTRA FLO™ WELDED PART NUMBER	SUPER TURBO™ PART NUMBER
2006-04	Wrangler Unlimited 4.0L I6	19403	17513	17748
2006-00	Wrangler 4.0L I6 (after 1/24/2000) Exc. Unlimited	19391	---	17664
2000-97	Wrangler 2.5L, 4.0L 4 Cyl., I6 (before 1/24/2000)	17345	17217	17731

JEEP YJ



SUSPENSION HARDWARE KIT

- For use with Rancho 2.5-in. Leaf Springs
- **Allows up to 33-in. tires**
- Leaf springs are designed to control torque roll while providing equal traction through limited axle wind-up
- Rancho springs are designed to maintain a soft factory ride
- Springs are carefully shot peened & finished in black
- Leaf spring bushings included
- Leaf springs are designed to re-use factory U-bolts

For use with Rancho Leaf Springs RS44050 and RS44150. This suspension system was developed using a 33 x 12.5 x R15 tire. U-bolt replacement kit also available.

PART NUMBER RS6444

Shocks sold separately

DONT FORGET THE STEERING STABILIZER
see page 28



YEAR	MODEL	VEHICLE HEIGHT	PRIMARY SUSPENSION SYSTEM	FRONT SPRING	FRONT KITS	REAR SPRINGS	REAR KITS
1996-86	4WD Wrangler YJ	2.5-in.	RS6444	RS44050	RS720	RS44150	RS721

RS5000™ SHOCK ABSORBERS

- **Ten-stage velocity sensitive valving**
- 5/8-in. (16mm) diameter piston rod*
- 1 3/8-in. (35mm) diameter piston*
- Protective boot included
- Limited Lifetime Warranty*

RS7000®MT SHOCK ABSORBERS

- 1.97-in. (50mm) body diameter
- **Monotube design** w/ high pressure nitrogen gas charge
- Off-road Fluon banded piston
- Brushed & Zinc plated with clear coated finish
- Ten-stage velocity sensitive valving
- 46mm Bore monotube construction
- 14mm Hardened steel rod
- Black natural rubber bushings
- Protective boot included
- Limited Lifetime Warranty and 90-Day Free Ride Offer*

RS9000™XL SHOCK ABSORBERS

- **2.75-in. (70mm) body diameter***
- Large 18mm Nitro Carb rod*
- 9-position tuning technology
- Nitrogen gas charged
- Liquid metallic finish
- Polyurethane bushings
- Protective boot included
- Limited Lifetime Warranty and 90-Day Free Ride Offer*



BENEFITS
Provides tuning specific for each vehicle
Adds strength and durability
Ensures performance in any environment
Protects the shock rod and oil seal
Guarantees your investment

VEHICLE HEIGHT	PART NUMBER	
	FRONT	REAR
0 - 1.5-in.	RS5168	RS5113
2.5-in. w/ Rancho RS6444	RS5168	RS5118



BENEFITS
Delivers both performance & appearance
Quicker damping response time
Provides a consistent seal between piston & pressure tube
Premium long lasting finish
Provides tuning specific for each vehicle
Ideal for larger light trucks, SUVs and more
Adds strength & durability
Enhances durability & reduced road harshness
Added protection for the shock rod & oil seal
Consumer protection

VEHICLE HEIGHT	PART NUMBER	
	FRONT	REAR
0 - 1.5-in.	RS7168	RS7113
2.5-in.	RS7168	RS7118



BENEFITS
Delivers both performance and appearance
Adds strength and durability
Provides 9 different levels of shock performance
Optimizes shock performance
Premium long lasting finish
Enhance shock performance and durability
Added protection for the shock rod and oil seal
Consumer protection

VEHICLE HEIGHT	PART NUMBER	
	FRONT	REAR
0 - 1.5-in.	RS999168	RS999113 ¹
2.5-in. w/ Rancho RS6444	RS999168	RS999118 ¹

¹ Requires Rancho shock adapter bracket. Trimming or modification may be required to provide proper tire clearance. Actual tire size varies between manufacturers.

JEEP YJ WRANGLER

RS5000™ STEERING STABILIZERS

Rancho® RS5000™ Steering Stabilizers are a simple and affordable way to enhance a vehicle's performance. Rancho Steering Stabilizers are ideal for off-road driving, towing and street applications. The Steering Stabilizers reduce wheel shimmy, bump steer and vibration as the shock series was engineered for vehicles with oversized tires and wheels. Steering Stabilizers can help reduce on or off-road driver fatigue. Rancho Steering Stabilizers are built from the foundation of the RS5000 series shock absorber – the world's best-selling shock! Covered by a Limited Lifetime Warranty.



POSITION	DESCRIPTION	PART NUMBER
Front	Single Steering Stabilizer	RS5407
Front	Optional Steering Stabilizer	RS5401 ¹

RS7000®MT STEERING STABILIZERS

Rancho® RS7000®MT Monotube Steering Stabilizers enhance a vehicle's performance, and are ideal for off roading, towing and street applications. Utilizing Monotube Technology, Rancho Steering Stabilizers help reduce wheel shimmy, bump steer, and vibration while tightening up steering performance by damping the tie rod to the axle. The shock was engineered for Jeeps and trucks running oversized tires and wheels. RS7000MT Steering Stabilizers, built from the foundation of the Rancho RS7000 series shock, can help reduce on- and off-road driver fatigue. The series is covered by a Limited Lifetime Warranty.



POSITION	DESCRIPTION	PART NUMBER
Front	Single Steering Stabilizer - Bolts to O.E. mounts - no bracket required	RS7407

¹ Part No. RS5401. Single large cylinder Steering Stabilizer.



CONVERTER-BACK EXHAUST 96-91 WRANGLER 2.5L, 4.0L 4 CYL., I6

- Super Turbo™ Muffler
- Patented internal Flow Director Technology w/ Fiberglass Matting
- Large internal flow tubes
- 304 Stainless steel spout on tailpipe
- Aluminized system

PART NUMBER 17309

YEAR	MODEL	PART NUMBER	SYSTEM INFO
96-91	Wrangler 2.5L, 4.0L 4 Cyl., I6	17309	Single - 2.25-in. system. 2.5-in. tip. Super Turbo™ Muffler
90-87	Wrangler 2.5L 4 Cyl.	17309	Single - 2.25-in. system. 2.5-in. tip. Super Turbo™ Muffler

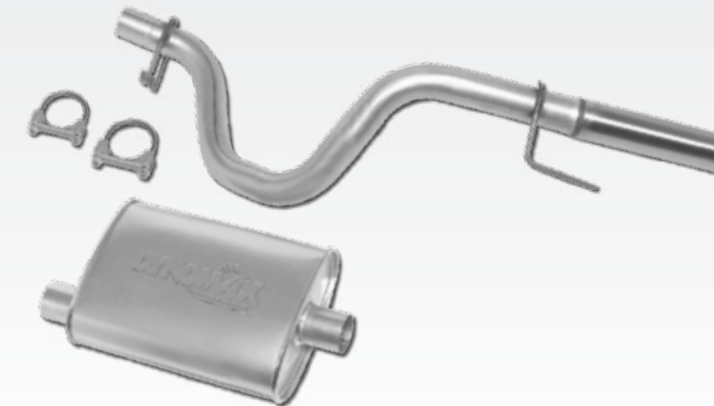

ULTRA FLO™ WELDED MUFFLER

- Stainless steel construction for lifelong protection
- 100-percent welded design for maximum durability
- Straight-through design ensures unrestricted exhaust flow and reduces back pressure
- Sound level: deep performance tone

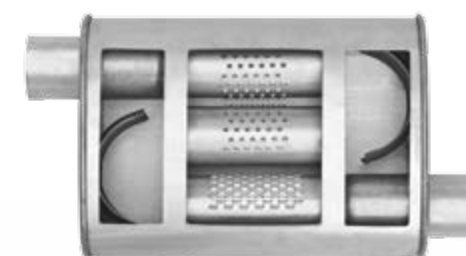

SUPER TURBO™ MUFFLER

- Patented internal flow director technology with fiberglass matting
- Large internal flow tubes improve exhaust flow
- 1-3/4-in. to 3-in. in/outlet configurations
- Sound level: mellow performance tone



YEAR	MODEL	DYNOMAX EXHAUST PART NUMBER	ULTRA FLO™ WELDED PART NUMBER	SUPER TURBO™ PART NUMBER
1996-91	Wrangler 2.5L, 4.0L 4 Cyl., I6	17309	17217	17731
1990-87	Wrangler 2.5L 4 Cyl.	17309	17217	17731

JEEP CJ



2.5-in. LEAF SPRING SYSTEM

- Leaf springs are designed to control torque roll while providing equal traction through limited axle wind-up
- Rancho springs progressively rated to control axle wind-up while maintaining a soft factory ride
- Springs are carefully shot peened and finished in black
- All Rancho Leaf Springs come complete with urethane bushings and pre-installed Zinc plated sleeves
- Complete kit requires all four leaf assemblies

Trimming or modification may be required to provide proper tire clearance. Actual tire size varies between manufacturers. Shocks sold separately.



DONT FORGET THE STEERING STABILIZER
see page 30

YEAR	MODEL	VEHICLE HEIGHT	FRONT SPRING	FRONT KITS	REAR SPRINGS	REAR KITS
1986-82	4WD CJ5, CJ7, CJ8	2.5-in.	RS44092	RS712	RS44192	RS711
1986-82	4WD CJ5, CJ7, CJ8	1-in.	-	RS712	-	RS711
1981	4WD CJ8	2.5-in.	RS44092	RS712	RS44192	RS711
1981	4WD CJ8	1-in.	-	RS712	-	RS711
1981-76	4WD CJ5, CJ7	2.5-in.	RS44092	RS712	RS44192	RS711
1981-76	4WD CJ5, CJ7	1-in.	-	RS712	-	RS711
1975-72	2/4WD CJ5, CJ6	2.5-in.	RS44062	RS712	RS44162	RS713
1975-72	4WD CJ5, CJ6	1-in.	-	-	-	-
1971-69	4WD CJ5, CJ6	2.5-in.	RS44062	RS712	RS44162	RS713
1971-69	4WD CJ5, CJ6	1-in.	-	-	-	-
1963-46	4WD CJ2A, CJ3A, CJ3B	2.5-in.	RS44020	RS714	RS44120	RS711



RS5000™ SHOCK ABSORBERS

FEATURES

- Ten-stage velocity sensitive valving
- 5/8-in. (16mm) diameter piston rod*
- 1 3/8-in. (35mm) diameter piston*
- Protective boot included
- Limited Lifetime Warranty*

BENEFITS

Provides tuning specific for each vehicle
Adds strength and durability
Ensures performance in any environment
Protects the shock rod and oil seal
Guarantees your investment

YEAR	VEHICLE HEIGHT	PART NUMBER FRONT	PART NUMBER REAR
1986-82	2.5-in.	RS5113	RS5118
1986-82	1-in.	RS5113	RS5113
1981	2.5-in.	RS5119	RS5118
1981	1-in.	RS5119	RS5113
1981-76	2.5-in.	RS5119	RS5118
1981-76	1-in.	RS5119	RS5113
1975-72	2.5-in.	RS5113	RS5113
1975-72	1-in.	RS5119	RS5119
1971-69	2.5-in.	RS5113	RS5113
1971-69	1-in.	RS5119	RS5119
1963-46	2.5-in.	RS5119	RS5113

* Requires Rancho shock adapter bracket.

JEEP CJ

RS7000®MT SHOCK ABSORBERS

FEATURES

- 1.97-in. (50mm) body diameter
- Monotube design w/ high pressure nitrogen gas charge
- Off-road Fluon banded piston
- Brushed & Zinc plated with clear coated finish
- Ten-stage velocity sensitive valving
- 46mm Bore monotube construction
- 14mm Hardened steel rod
- Black natural rubber bushings
- Protective boot included
- Limited Lifetime Warranty and 90-Day Free Ride Offer*

BENEFITS

Delivers both performance & appearance
Quicker damping response time
Provides a consistent seal between piston & pressure tube
Premium long lasting finish
Provides tuning specific for each vehicle
Ideal for larger light trucks, SUVs and more
Adds strength & durability
Enhances durability & reduced road harshness
Added protection for the shock rod & oil seal
Consumer protection



YEAR	MODEL	VEHICLE HEIGHT	PART NUMBER FRONT	PART NUMBER REAR
86-82	CJ5, CJ7, CJ8	2.5-in.	RS7113	RS7118
86-82	CJ5, CJ7, CJ8	0 - 1.5-in.	RS7113	RS7113
86-76	CJ5, CJ7, CJ8	2-in.	RS7119	RS7118
81-76	CJ5, CJ7, CJ8	2.5-in.	RS7119	-
81-76	CJ5, CJ7, CJ8	0 - 1.5-in.	RS7119	-
75-53	CJ5, CJ6	2 - 3-in.	RS7113	RS7113
75-53	CJ5, CJ6	0-in.	RS7119	RS7119
63-41	CJ2A, CJ3A, CJ3B	0 - 3-in.	RS7119	RS7119

RS9000™XL SHOCK ABSORBERS

FEATURES

- 2.75-in. (70mm) body diameter*
- Large 18mm Nitro Carb rod*
- 9-position tuning technology
- Nitrogen gas charged
- Liquid metallic finish
- Polyurethane bushings
- Protective boot included
- Limited Lifetime Warranty and 90-Day Free Ride Offer*

BENEFITS

Delivers both performance and appearance
Adds strength and durability
Provides 9 different levels of shock performance
Optimizes shock performance
Premium long lasting finish
Enhance shock performance and durability
Added protection for the shock rod and oil seal
Consumer protection



YEAR	VEHICLE HEIGHT	PART NUMBER FRONT	PART NUMBER REAR
1986-82	2.5-in.	RS999113	RS999118 ¹
1986-82	1-in.	RS999113	RS999113 ¹
1981-76	2.5-in.	RS999119	RS999118
1981-76	1-in.	RS999119	RS999113
1975-72	2.5-in.	RS999113	RS999113
1975-72	1-in.	RS999119	RS999119
1971-69	2.5-in.	RS999113	RS999113
1971-69	1-in.	RS999119	RS999119
1963-46	2.5-in.	RS999119	RS999113

RS5000™ STEERING STABILIZERS

Rancho® RS5000™ Steering Stabilizers are a simple and affordable way to enhance a vehicle's performance. Rancho Steering Stabilizers are ideal for off-road driving, towing and street applications. The Steering Stabilizers reduce wheel shimmy, bump steer and vibration as the shock series was engineered for vehicles with oversized tires and wheels. Steering Stabilizers can help reduce on or off-road driver fatigue. Rancho Steering Stabilizers are built from the foundation of the RS5000 series shock absorber – the world's best-selling shock! Covered by a Limited Lifetime Warranty.

¹ Requires Rancho shock adapter bracket.



DESCRIPTION	PART NUMBER	BRACKET KIT
Steering Stabilizer Kit	RS97345	-
Single Steering Stabilizer	RS5402	RS5508



ULTRA FLO™ WELDED MUFFLER

- Stainless steel construction for lifelong protection
- 100-percent welded design for maximum durability
- Straight-through design ensures unrestricted exhaust flow and reduces back pressure
- Sound level: deep performance tone



SUPER TURBO™ MUFFLER

- Patented internal flow director technology with fiberglass matting
- Large internal flow tubes improve exhaust flow
- 1-3/4-in. to 3-in. in/outlet configurations
- Sound level: mellow performance tone



YEAR	MODEL	PIPE DIAMETER	ULTRA FLO™ WELDED PART NUMBER	SUPER TURBO™ PART NUMBER
1986-66	CJ5, CJ6, CJ7, CJ8 4 Cyl., V6, V8	2-in.	17514	17730
		2.25-in.	17217	17731
		2.5-in.	17219	17733

Modifications and/or additional parts may be required.

1986-46



RS5000™ SHOCK ABSORBERS

- FEATURES**
- Ten-stage velocity sensitive valving
 - 5/8-in. (16mm) diameter piston rod*
 - 1 3/8-in. (35mm) diameter piston*
 - Protective boot included
 - Limited Lifetime Warranty*

- BENEFITS**
- Provides tuning specific for each vehicle
 - Adds strength and durability
 - Ensures performance in any environment
 - Protects the shock rod and oil seal
 - Guarantees your investment

YEAR	MODEL	VEHICLE HEIGHT	PART NUMBER	
			FRONT	REAR
2004-99	Grand Cherokee WJ	0-in.	RS5128	RS5260
2001-99	Grand Cherokee WJ	2-in.	RS5239	RS5260
1998-93	Grand Cherokee ZJ	0-in.	RS5128	RS5259
1998-93	Grand Cherokee ZJ	2-in.	RS5239	RS5194
1998-93	Grand Cherokee ZJ	3-in.	RS5239	RS5194



RS7000® MT SHOCK ABSORBERS

- FEATURES**
- 1.97-in. (50mm) body diameter
 - Monotube design w/ high pressure nitrogen gas charge
 - Off-road Fluon banded piston
 - Brushed & Zinc plated with clear coated finish
 - Ten-stage velocity sensitive valving
 - 46mm Bore monotube construction
 - 14mm Hardened steel rod
 - Black natural rubber bushings
 - Protective boot included
 - Limited Lifetime Warranty and 90-Day Free Ride Offer*

- BENEFITS**
- Delivers both performance & appearance
 - Quicker damping response time
 - Provides a consistent seal between piston & pressure tube
 - Premium long lasting finish
 - Provides tuning specific for each vehicle
 - Ideal for larger light trucks, SUVs and more
 - Adds strength & durability
 - Enhances durability & reduced road harshness
 - Added protection for the shock rod & oil seal
 - Consumer protection

YEAR	MODEL	VEHICLE HEIGHT	PART NUMBER	
			FRONT	REAR
91-84	Grand Wagoneer	0-in.	RS7113	RS7113
91-84	Grand Wagoneer	2.5-in.	RS7118	RS7118



RS9000™ XL SHOCK ABSORBERS

- FEATURES**
- 2.75-in. (70mm) body diameter*
 - Large 18mm Nitro Carb rod*
 - 9-position tuning technology
 - Nitrogen gas charged
 - Liquid metallic finish
 - Polyurethane bushings
 - Protective boot included
 - Limited Lifetime Warranty and 90-Day Free Ride Offer*

- BENEFITS**
- Delivers both performance and appearance
 - Adds strength and durability
 - Provides 9 different levels of shock performance
 - Optimizes shock performance
 - Premium long lasting finish
 - Enhance shock performance and durability
 - Added protection for the shock rod and oil seal
 - Consumer protection

YEAR	MODEL	VEHICLE HEIGHT	PART NUMBER	
			FRONT	REAR
2004-99	Grand Cherokee WJ	0-in.	RS999128	RS999260
2001-99	Grand Cherokee WJ	2-in.	RS999239	RS999260
1998-93	Grand Cherokee ZJ	0-in.	RS999128	RS999259
1998-93	Grand Cherokee ZJ	2-in.	RS999239	RS999194
1998-93	Grand Cherokee ZJ	3-in.	RS999239	RS999194



RS5000™ STEERING STABILIZERS

Rancho® RS5000™ Steering Stabilizers are a simple and affordable way to enhance a vehicle's performance. Rancho Steering Stabilizers are ideal for off-road driving, towing and street applications. The Steering Stabilizers reduce wheel shimmy, bump steer and vibration as the shock series was engineered for vehicles with oversized tires and wheels. Steering Stabilizers can help reduce on or off-road driver fatigue. Rancho Steering Stabilizers are built from the foundation of the RS5000 series shock absorber – the world's best-selling shock! Covered by a Limited Lifetime Warranty.

YEAR	MODEL	PART NUMBER
2004-99	Grand Cherokee WJ	RS5409
1998-93	Grand Cherokee ZJ	RS5401

RS7000® MT STEERING STABILIZERS



Rancho® RS7000® MT Monotube Steering Stabilizers enhance a vehicle's performance, and are ideal for off roading, towing and street applications. Utilizing Monotube Technology, Rancho Steering Stabilizers help reduce wheel shimmy, bump steer, and vibration while tightening up steering performance by damping the tie rod to the axle. The shock was engineered for Jeeps and trucks running oversized tires and wheels. RS7000MT Steering Stabilizers, built from the foundation of the Rancho RS7000 series shock, can help reduce on- and off-road driver fatigue. The series is covered by a Limited Lifetime Warranty.

YEAR	DESCRIPTION	PART NUMBER
1998-93	Single Steering Stabilizer - Bolts to O.E. mounts - no bracket required	RS7401

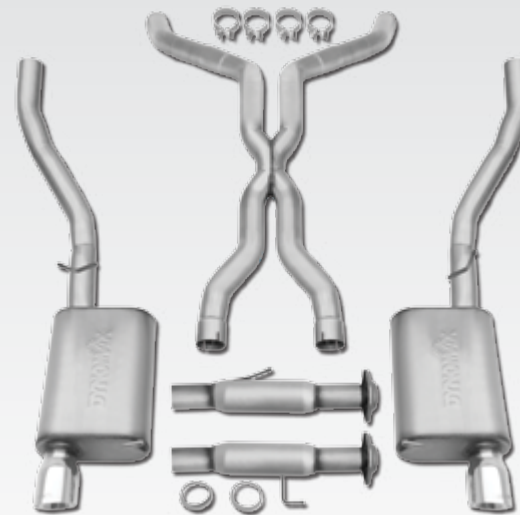

STAINLESS STEEL DUAL EXHAUST 2014-11 GRAND CHEROKEE 5.7L V8

- Stainless steel Ultra Flo™ Welded Mufflers
- 4-in. outlet, single wall, buffed and polished, 6-in. OAL SS slant cut tips
- 2.5-in. Mandrel bent stainless steel tubing

PART NUMBER 39513



YEAR	MODEL	PART NUMBER	SYSTEM INFO
2014-11	Grand Cherokee 3.6L V6	39519	Single - 2.5-in. system. 4-in. tip. Ultra Flo™ Welded Muffler
2009-08	Grand Cherokee 3.0L V6 CRD Turbo Diesel	39478	Single - 3-in. system. 3-in. tip. Ultra Flo™ Welded Muffler
2010-05	Grand Cherokee 3.7L, 4.7L, 5.7L V6, V8	19421	Single - 2.5-in. system. 3-in. tip. Ultra Flo™ Welded Muffler
2001-99	Grand Cherokee 4.0L, 4.7L I6, V8	19312	Single - 2.5-in. system. 3-in. tip. Super Turbo™ Muffler
1997-93	Grand Cherokee, Grand Wagoneer 4.0L, 5.2L I6, V8	17403	Single - 2.25-in. system. 3-in. tip. Super Turbo™ Muffler



ULTRA FLO™ WELDED MUFFLER

- Stainless steel construction for lifelong protection
- 100-percent welded design for maximum durability
- Straight-through design ensures unrestricted exhaust flow and reduces back pressure
- Sound level: deep performance tone

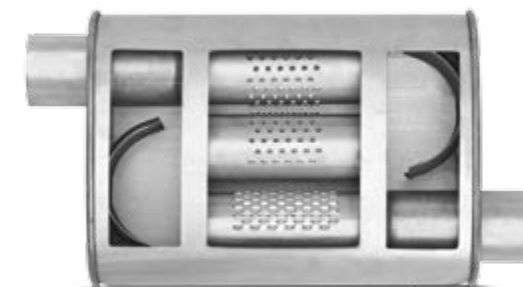

SUPER TURBO™ MUFFLER

- Patented internal flow director technology with fiberglass matting
- Large internal flow tubes improve exhaust flow
- 1-3/4-in. to 3-in. in/outlet configurations
- Sound level: mellow performance tone



YEAR	MODEL	DYNOMAX EXHAUST PART NUMBER	ULTRA FLO™ WELDED PART NUMBER	SUPER TURBO™ PART NUMBER
2009-08	Grand Cherokee 3.0L V6 CRD Turbo Diesel	39478	17566	-
2010-05	Grand Cherokee 3.7L, 4.7L, 5.7L V6, V8	19421	17236	-
2001-99	Grand Cherokee 4.0L, 4.7L I6, V8	19312	17513	17748
1998-93	Grand Cherokee 4.0L, 5.2L I6, V8	17403	17512	17747
1993	Grand Wagoneer 5.2L V6, V8	17403	17512	17747

2013-93



2.5-in. SUSPENSION SYSTEM

- Allows for 31-in. tire or 33-in. tire with trimming
- New heavy-duty tubular-style front links with grease zerk fittings
- Allows for reuse of the stock wheels
- Kit includes U-Bolts and Add-a-leaf
- Includes Steering Stabilizer

Available in red finish only. This suspension system was developed using a 31 x 11.5 x R15 tire on a 15 x 8-in. wheel with 3.75 B.S.

PART NUMBER RS66000 (Chrysler Rear Axle)

PART NUMBER RS66001 (Dana 35 Rear Axle)

Optional full rear leaf pack and U-Bolt/Bushing kits sold separately. Rear leaf pack part number RS44148. U-Bolt kit part number RS746.

FRONT EXTENDED LENGTH BRAKE LINES

- Stainless steel braided Brake Lines are protected with a vinyl cover
- Provides a firmer and more responsive braking
- Mounting brackets included where necessary
- Sold in pairs

PART NUMBER RS6249 (21.5-INCH)



Trimming or modification may be required to provide proper tire clearance. Actual tire size varies between manufacturers.

RS5000™ SHOCK ABSORBERS

- FEATURES**
- Ten-stage velocity sensitive valving
 - 5/8-in. (16mm) diameter piston rod*
 - 1 3/8-in. (35mm) diameter piston*
 - Protective boot included
 - Limited Lifetime Warranty*



- BENEFITS**
- Provides tuning specific for each vehicle
 - Adds strength and durability
 - Ensures performance in any environment
 - Protects the shock rod and oil seal
 - Guarantees your investment

VEHICLE HEIGHT	PART NUMBER	
	FRONT	REAR
0-in.	RS5128	RS5129
2.5-in.	RS5239	RS5129

RS7000®MT SHOCK ABSORBERS

- FEATURES**
- 1.97-in. (50mm) body diameter
 - **Monotube design** w/ high pressure nitrogen gas charge
 - Off-road Fluon banded piston
 - Brushed & Zinc plated with clear coated finish
 - Ten-stage velocity sensitive valving
 - 46mm Bore monotube construction
 - 14mm Hardened steel rod
 - Black natural rubber bushings
 - Protective boot included
 - Limited Lifetime Warranty and 90-Day Free Ride Offer*



- BENEFITS**
- Delivers both performance & appearance
 - Quicker damping response time
 - Provides a consistent seal between piston & pressure tube
 - Premium long lasting finish
 - Provides tuning specific for each vehicle
 - Ideal for larger light trucks, SUVs and more
 - Adds strength & durability
 - Enhances durability & reduced road harshness
 - Added protection for the shock rod & oil seal
 - Consumer protection

VEHICLE HEIGHT	PART NUMBER	
	FRONT	REAR
0-in.	RS7128	RS7129
2.5-3-in.	RS7239	RS7129

RS9000™XL SHOCK ABSORBERS

- FEATURES**
- 2.75-in. (70mm) body diameter*
 - Large 18mm Nitro Carb rod*
 - 9-position tuning technology
 - Nitrogen gas charged
 - Liquid metallic finish
 - Polyurethane bushings
 - Protective boot included
 - Limited Lifetime Warranty and 90-Day Free Ride Offer*



- BENEFITS**
- Delivers both performance and appearance
 - Adds strength and durability
 - Provides 9 different levels of shock performance
 - Optimizes shock performance
 - Premium long lasting finish
 - Enhance shock performance and durability
 - Added protection for the shock rod and oil seal
 - Consumer protection

VEHICLE HEIGHT	PART NUMBER	
	FRONT	REAR
0-in.	RS999128	RS999129
2.5-3-in.	RS999239	RS999129

RS5000™ STEERING STABILIZERS

Rancho® RS5000™ Steering Stabilizers are a simple and affordable way to enhance a vehicle's performance. Rancho Steering Stabilizers are ideal for off-road driving, towing and street applications. The Steering Stabilizers reduce wheel shimmy, bump steer and vibration as the shock series was engineered for vehicles with oversized tires and wheels. Steering Stabilizers can help reduce on or off-road driver fatigue. Rancho Steering Stabilizers are built from the foundation of the RS5000 series shock absorber – the world's best-selling shock! Covered by a Limited Lifetime Warranty.

POSITION	DESCRIPTION	PART NUMBER
Front	Single Steering Stabilizer	RS5401



RS7000®MT STEERING STABILIZERS

Rancho® RS7000®MT Monotube Steering Stabilizers enhance a vehicle's performance, and are ideal for off roading, towing and street applications. Utilizing Monotube Technology, Rancho Steering Stabilizers help reduce wheel shimmy, bump steer, and vibration while tightening up steering performance by damping the tie rod to the axle. The shock was engineered for Jeeps and trucks running oversized tires and wheels. RS7000MT Steering Stabilizers, built from the foundation of the Rancho RS7000 shock, can help reduce on- and off-road driver fatigue. The series is covered by a Limited Lifetime Warranty.

YEAR	DESCRIPTION	PART NUMBER
2001-84	Single Steering Stabilizer - Bolts to O.E. mounts - no bracket required	RS7401



JEEP XJ



CONVERTER-BACK EXHAUST

- Super Turbo™ Muffler
- Patented internal Flow Director Technology w/ Fiberglass Matting
- Large internal flow tubes
- 304 Stainless steel spout on tailpipe
- Aluminized system



YEAR	MODEL	PART NUMBER	SYSTEM INFO
2001-93	Cherokee 4.0L I6	17340	Single - 2.25-in. system. 2.5-in. tip. Super Turbo™ Muffler
1992-87	Cherokee, Wagoneer 4.0L I6	17463	Single - 2.5-in. system. Super Turbo™ Muffler
1992-86	Cherokee, Wagoneer Sport Wagon 2.5L 4 Cyl.	17463	Single - 2.5-in. system. Super Turbo™ Muffler

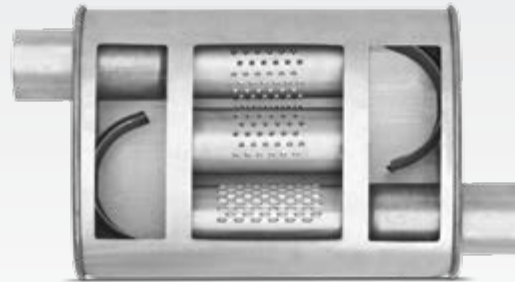
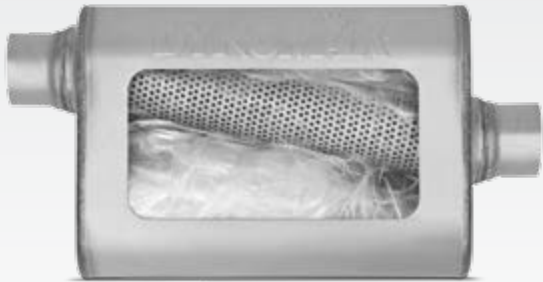

ULTRA FLO™ WELDED MUFFLER

- Stainless steel construction for lifelong protection
- 100-percent welded design for maximum durability
- Straight-through design ensures unrestricted exhaust flow and reduces back pressure
- Sound level: deep performance tone

SUPER TURBO™ MUFFLER

- Patented internal flow director technology with fiberglass matting
- Large internal flow tubes improve exhaust flow
- 1-3/4-in. to 3-in. in/outlet configurations
- Sound level: mellow performance tone



YEAR	MODEL	DYNOMAX EXHAUST PART NUMBER	ULTRA FLO™ WELDED PART NUMBER	SUPER TURBO™ PART NUMBER
2001-93	Cherokee 4.0L I6	17340	17512	17747
1992-87	Cherokee, Wagoneer 4.0L I6	17463	17513	17748
1992-86	Cherokee, Wagoneer Sport Wagon 2.5L 4 Cyl.	17463	17513	17748



2001-84

JEEP XJ



JEEP KK



RS5000™ SHOCK ABSORBERS

- | | | | |
|-----------------|--|-----------------|---|
| FEATURES | • Ten-stage velocity sensitive valving | BENEFITS | Provides tuning specific for each vehicle |
| | • 5/8-in. (16mm) diameter piston rod* | | Adds strength and durability |
| | • 1 3/8-in. (35mm) diameter piston* | | Ensures performance in any environment |
| | • Protective boot included | | Protects the shock rod and oil seal |
| | • Limited Lifetime Warranty* | | Guarantees your investment |

YEAR	MODEL	VEHICLE HEIGHT	PART NUMBER FRONT	REAR
2011-02	Liberty KK	0-in.	RS5764	RS5284



RS9000™XL SHOCK ABSORBERS

- | | | | |
|---|----------------------------------|-----------------|--|
| FEATURES | • 2.75-in. (70mm) body diameter* | BENEFITS | Delivers both performance and appearance |
| | • Large 18mm Nitro Carb rod* | | Adds strength and durability |
| | • 9-position tuning technology | | Provides 9 different levels of shock performance |
| | • Nitrogen gas charged | | Optimizes shock performance |
| | • Liquid metallic finish | | Premium long lasting finish |
| | • Polyurethane bushings | | Enhance shock performance and durability |
| | • Protective boot included | | Added protection for the shock rod and oil seal |
| • Limited Lifetime Warranty and 90-Day Free Ride Offer* | Consumer protection | | |

YEAR	MODEL	VEHICLE HEIGHT	PART NUMBER FRONT	REAR
2011-02	Liberty KK	0-in.	RS999764	RS999284



STAINLESS STEEL EXHAUST 2013-08 JEEP LIBERTY KK 3.7L

- Stainless steel Ultra Flo™ Welded Muffler
- 3-in. outlet, single wall, buffed and polished, 12-in. OAL SS slant cut tip
- 2.5-in. Mandrel bent stainless steel tubing

PART NUMBER 39475

YEAR	MODEL	DYNOMAX EXHAUST PART NUMBER
2013-08	Liberty KK 3.7L	39475
2007-02	Liberty KJ 3.7L	19392
2006-05	Liberty KJ 2.8L Diesel / CRD	19392
13-07	Patriot MK 2.4L	39477



KJ/KK/MK

PERFORMANCE SHOCK ABSORBERS

YEAR	MODEL	RAISED HEIGHT		RS9000™XL		RS7000®MT		RS5000™	
		FRONT	REAR	FRONT	REAR	FRONT	REAR	FRONT	REAR
2014-07	JK 2/4 Door 2/4WD	0-2-in.	0-2-in.	RS999326	RS999327	RS7326	RS7328	RS5326	RS5327
2014-07	JK Rubicon 2/4 Door 2/4WD	0-2-in.	0-2-in.	RS999326	RS999328	RS7326	RS7328	RS5326	RS5328
2014-07	JK Rubicon 2/4 Door 2/4WD - w/ Rancho RS66106B or RS66107/B	3-in.	3-in.	RS999329	RS999330	RS7329	RS7330	RS5329	RS5330
2014-07	JK Rubicon 2/4 Door 2/4WD - w/ Rancho RS66105/B	4-in.	4-in.	RS999331	RS999332	RS7331	RS7330	RS5331	RS5332
2014-07	JK Rubicon 2/4 Door 2/4WD - w/ Rancho RS6517/B, RS66102B, RS66103/B or RS66104/B	4-in.	4-in.	RS999331	RS999332	RS7331	RS7330	RS5331	RS5332
2014-07	JK Rubicon 2/4 Door 2/4WD - w/ Rancho RS6507/B	4-in.	4-in.	RS999329	RS999330	RS7331	RS7330	RS5329	RS5330
2006-97	Wrangler TJ/LJ 4WD	0-in.	0-in.	RS999128	RS999240	RS7128	RS7240	RS5128	RS5240
2006-97	Wrangler TJ/LJ 4WD w/ Rancho RS6503	2.5-in.	2.5-in.	RS999239	RS999241	RS7239	RS7241	RS5239	RS5241
2006-97	Wrangler TJ/LJ 4WD w/ Rancho RS6501 or RS6504	3.5-in.	3.5-in.	RS999255	RS999256	RS7255	RS7256	RS5255	RS5256
2003-97	Wrangler TJ/LJ 4WD	5-6-in.	5-6-in.	RS999061	RS999062	-	-	-	-
2006-97	Wrangler TJ/LJ 4WD	5-6-in.	5-6-in.	-	-	RS7061	RS7062	-	-
1996-86	Wrangler YJ 4WD	0-1.5-in.	0-1.5-in.	RS999168	RS999113 ¹	RS7168	RS7113	RS5168	RS5113
1996-86	Wrangler YJ 4WD w/ Rancho RS6444	2.5-in.	2.5-in.	RS999168	RS999113 ¹	RS7168	RS7118	RS5168	RS5113
1986-82	CJ5, CJ7, CJ8 4WD	1-in.	1-in.	RS999113	RS999113 ¹	RS7113	RS7113	RS5113	RS5113
1986-82	CJ5, CJ7, CJ8 4WD	2.5-in.	2.5-in.	RS999113	RS999118 ¹	RS7113	RS7118	RS5113	RS5118
1981	CJ8 4WD	1-in.	1-in.	RS999119	RS999113	-	-	RS5119	RS5113
1981	CJ8 4WD	2.5-in.	2.5-in.	RS999119	RS999118	-	-	RS5119	RS5118
1981-76	CJ5, CJ7 4WD	1-in.	1-in.	RS999119	RS999113	-	-	RS5119	RS5113
1981-76	CJ5, CJ7 4WD	2.5-in.	2.5-in.	RS999119	RS999118	-	-	RS5119	RS5118
1975-53	CJ5, CJ6 4WD	2-3-in.	2-3-in.	-	-	RS7113	RS7113	-	-
1975-72	CJ5, CJ6 4WD	1-in.	1-in.	RS999119	RS999119	-	-	RS5119	RS5119
1975-72	CJ5, CJ6 2/4WD	2.5-in.	2.5-in.	RS999113	RS999113	-	-	RS5113	RS5113
1971-69	CJ5, CJ6 4WD	1-in.	1-in.	RS999119	RS999119	-	-	RS5119	RS5119
1971-69	CJ5, CJ6 4WD	2.5-in.	2.5-in.	RS999113	RS999113	-	-	RS5113	RS5113
1963-46	CJ2A, CJ3A, CJ3B 4WD	2.5-in.	2.5-in.	RS999119	RS999113	-	-	RS5119	RS5113
2007-05	Grand Cherokee WJ	0-in.	0-in.	-	-	-	-	RS5826	RS5398
2004-99	Grand Cherokee WJ	0-in.	0-in.	RS999128	RS999260	RS7113	RS7113	RS5128	RS5260
2001-99	Grand Cherokee WJ	2-in.	2-in.	RS999239	RS999260	-	-	RS5239	RS5260
1998-93	Grand Cherokee ZJ	0-in.	0-in.	RS999128	RS999259	-	-	RS5128	RS5259
1998-93	Grand Cherokee ZJ	2-3-in.	2-3-in.	RS999239	RS999194	-	-	RS5239	RS5194
1991-84	Grand Wagoneer 4WD	0-in.	0-in.	RS999113	RS999113	RS7113	RS7113	RS5113	RS5113
1991-84	Grand Wagoneer 4WD	2.5-in.	2.5-in.	RS999118	RS999118	RS7118	RS7118	RS5118	RS5118

¹ Requires Rancho shock adapter bracket

PERFORMANCE SHOCKS ABSORBERS

YEAR	MODEL	RAISED HEIGHT		RS9000™XL		RS7000®MT		RS5000™	
		FRONT	REAR	FRONT	REAR	FRONT	REAR	FRONT	REAR
2001-84	Cherokee XJ 4WD	0-in.	0-in.	RS999128	RS999129	RS7128	RS7129	RS5128	RS5129
2001-84	Cherokee XJ 4WD	2.5-3-in.	2.5-3-in.	RS999239	RS999129	RS7239	RS7129	RS5239	RS5129
1990-84	Wagoneer XJ 4WD Exc. Grand Wagoneer	0-in.	0-in.	RS999128	RS999129	RS7128	RS7129	RS5128	RS5129
1983-76	Wagoneer 4WD Full Size	0-in.	0-in.	RS999113	RS999113	RS7113	RS7113	RS5113	RS5113
1983-76	Wagoneer 4WD Full Size	2-3-in.	2-3-in.	RS999118	RS999118	RS7118	RS7118	RS5118	RS5118
1975	Wagoneer 4WD Full Size	0-in.	0-in.	RS999113	RS999120	-	-	RS5113	RS5120
1975	Wagoneer 4WD Full Size	2-3-in.	2-3-in.	RS999118	RS999119	-	-	RS5118	RS5119
1974	Wagoneer 4WD Full Size	0-in.	0-in.	RS999113	RS999119	-	-	RS5113	RS5119
1974	Wagoneer 4WD Full Size	2-3-in.	2-3-in.	RS999118	RS999113	RS7118	RS7113	RS5118	RS5113
1973-63	Wagoneer 4WD Full Size	0-in.	0-in.	RS999113	RS999113	RS7113	RS7113	RS5113	RS5113
1973-63	Wagoneer 4WD Full Size	2-3-in.	2-3-in.	RS999116	RS999118	-	-	RS5116	RS5118
2011-02	Liberty	0-in.	0-in.	RS999764	RS999284	-	-	RS5764	RS5284
1992-86	Comanche 2/4WD Mid Size	0-in.	0-in.	RS999128	RS999118	RS7128	RS7118	RS5128	RS5118
1992-86	Comanche 2/4WD Mid Size	3-in.	2-in. Max	RS999239	RS999118	RS7239	RS7118	RS5239	RS5118
1986-82	Scrambler 4WD	0-1.5-in.	0-1.5-in.	RS999113	RS999113	RS7113	RS7113	RS5113	RS5113
1986-82	Scrambler 4WD	2.5-in.	2.5-in.	RS999113	RS999118	RS7113	RS7118	RS5113	RS5118
1986-76	Scrambler Comp. Sys. 4WD	2-in.	2-in.	RS999119	RS999118	-	-	RS5119	RS5118
1981-76	Scrambler 4WD	0-1.5-in.	0-1.5-in.	RS999119	RS999113	-	-	RS5119	RS5113
1981-76	Scrambler 4WD	2.5-in.	2.5-in.	RS999119 ²	RS999118	-	-	RS5119 ²¹	RS5118
1975-53	M Series M38A1 4WD	0-in.	0-in.	RS999119	RS999119	-	-	RS5119	RS5119
1975-53	M Series M38A1 4WD	2-3-in.	2-3-in.	RS999113	RS999113	RS7113	RS7113	RS5113	RS5113
1963-41	M Series MB, M38 4WD	0-in.	0-in.	-	RS999119	-	-	-	RS5119
1963-41	M Series MB, M38 4WD	2-3-in.	2-3-in.	RS999119	RS999113	-	-	RS5119	RS5113
1973-69	Jeepster, C101, Commando	0-in.	0-in.	RS999119	RS999113	-	-	RS5119	RS5113
1973-69	Jeepster, C101, Commando	2-3-in.	2-3-in.	RS999113	RS999118	RS7113	RS7118	RS5113	RS5118
1962-47	Utility Wagon 4WD	0-in.	0-in.	-	RS999113	-	RS7113	-	RS5113
1962-47	Utility Wagon 4WD	1.5-in.	3-in.	RS999119	RS999116	-	-	RS5119	RS5116
1986-74	J Series J10, J20 4WD	0-in.	0-in.	RS999113	RS999113	RS7113	RS7113	RS5113	RS5113
1986-74	J Series J10, J20 4WD	2-3-in.	2-3-in.	RS999118	RS999118	RS7118	RS7118	RS5118	RS5118
1973-63	J Series Gladiator 4WD	0-in.	0-in.	RS999113	RS999113	RS7113	RS7113	RS5113	RS5113
1973-63	J Series Gladiator 4WD	2-3-in.	2-3-in.	RS999116	RS999118	-	-	RS5116	RS5118
1962-47	J Series Utility Truck 4WD	0-in.	0-in.	-	RS999113	-	RS7113	-	RS5113
1962-47	J Series Utility Truck 4WD	1.5-in.	3-in.	RS999119	RS999116	-	-	RS5119	RS5116

UNIVERSAL SHOCKS - CUSTOMER OFF-ROAD USE ONLY

RS9000XL™	RS5000™	MOUNTING CODES -		UPPER	LOWER	LENGTHS - Comp. (in)		Ext. (in)	Travel (in)
-	RS5298 ³			LS38	LS38	10.875	16.750	5.8750	
RS999028	-			L1	L1	16.875	28.125	11.250	
RS999012	RS5012			L1	L1	19.375	32.250	12.875	
RS999034	RS5034			L1	L1	20.125	34.000	13.875	
RS999036	RS5036			L1	L1	21.125	36.125	15.000	
RS7000MT™		MOUNTING CODES -		UPPER	LOWER	LENGTHS - Comp. (in)		Ext. (in)	Travel (in)
RS7391				S51	L1	12.375	18.875	6.500	
RS7008				L1	L1	13.750	21.500	7.750	
RS7118				L1	L1	14.250	22.250	8.000	
RS7112				L1	L1	16.250	25.750	9.500	
RS7388				L1	L1	18.000	29.500	11.500	
RS7034				L1	L1	20.500	34.500	14.000	

² On 1976-81 CJ5, CJ7, Scrambler 2.5-in. Suspension System RS5119 & RS999119 may be too short and you must use RS5113 & RS999113 with Bump Stop Kit No. RS8203.

³ For use in multi-shock setups only. LS38 - Loop - bushing/sleeve. L1 - Loop - bushing. S51 - stem. B designates black finish.