

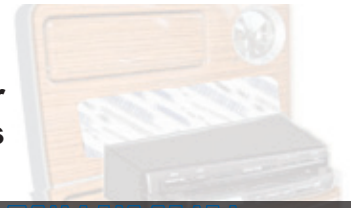

Pacific Accessory Corporation

TATO

JBL Amplifier Turn-On Interface for Toyota CANbus Vehicles



The TATO is designed to control the power and audio levels of the factory installed JBL amplifier allowing the OEM radio to be removed and replaced with an aftermarket stereo.

Installation:

Disconnect the factory radio from the OEM wiring harness and remove it from the vehicle. Make the following connections of the TATO wiring harness to the aftermarket radio:

Connections:

- Yellow Wire - Connect to 12 Volt Constant Power on aftermarket radio
- Red Wire - Connect to Accessory on aftermarket radio
- Black Wire - Connect to Ground on aftermarket radio
- Orange/White Wire - Connect to Dimmer on aftermarket radio
- *11 Pin Harness - Connect to PAC's SWI-X, SWI-JACK, SWI-PS or SWI-ECL2 (Sold Separately)
- Red Bullet Connector - Connect to Accessory
- Black Bullet Connector - Connect to Ground
- Connect the 4 RCA connectors to the RCA outputs of the aftermarket radio
 - Front Left - White RCA Front Right - Grey RCA
 - Rear Left - Green RCA Rear Right - Purple RCA

If connecting the TATO to a head unit with only 2 Channel RCA outputs, use two pairs of RCA splitters (1M-2F) to split the signal. Failure to connect all 4 inputs of the TATO will result in loss of audio performance. Fade audio controls will only function with a 4 channel aftermarket deck.

Connections to the TATO Interface:

- Connect 24-pin translucent connector to the side of the TATO.
- Connect 8-pin DIN cable to the plug on the side of the TATO.

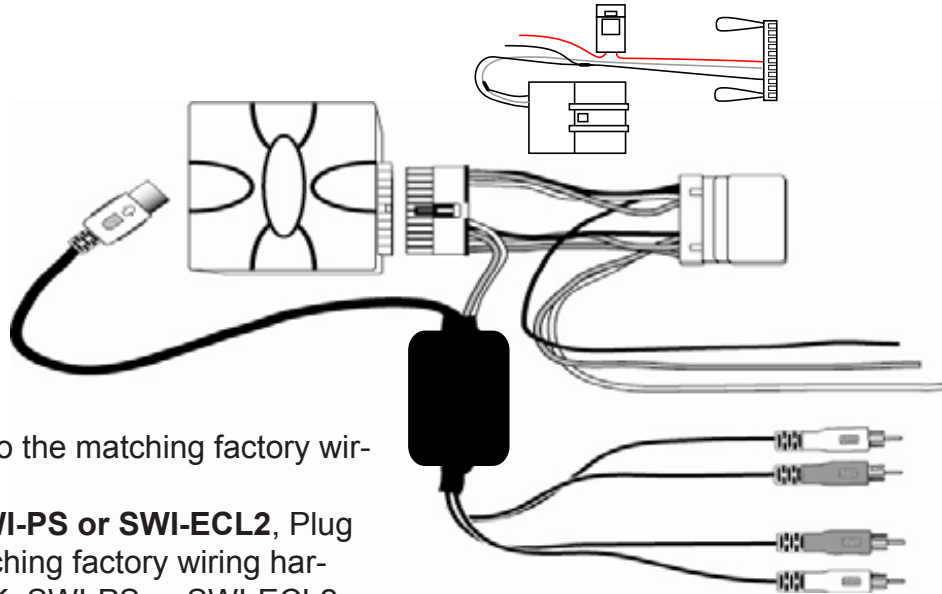

Connections to the Vehicle:

- Plug the main 20-pin Toyota harness into the matching factory wiring harness.
- *If using PAC's SWI-X, SWI-JACK, SWI-PS or SWI-ECL2, Plug the smaller 20-pin harness into the matching factory wiring harness. Program PAC's SWI-X, SWI-JACK, SWI-PS or SWI-ECL2 for version #8 and follow the programming instructions included with PAC's SWI-X, SWI-JACK, SWI-PS or SWI-ECL2.

Adjusting Volume Output:

When initially connecting the TATO to the vehicle the max output might not meet that of the factory radio. If the volume is low you can adjust the output using the dip switches on the side of the module. It is recommended to use a 4 volt RMS capable aftermarket radio. When adjusting the gain output it is recommended to start with the plus 7dB setting and working your way down.

Note: It may take up to 10 seconds before the gain adjustment is heard.

The dB gain adjustments are as follows:

Dip Switch Settings			
Dip Switch 1	Dip Switch 2	Dip Switch 3	dB Gain
Off	Off	Off	Plus 0dB
On	Off	Off	Plus 1dB
Off	On	Off	Plus 2dB
On	On	Off	Plus 3dB
Off	Off	On	Plus 4dB
On	Off	On	Plus 5dB
Off	On	On	Plus 6dB
On	On	On	Plus 7dB

Set all other dip switches 4-8 to OFF (up) position

Troubleshooting

Symptom	Resolution
No audio from rear speakers	all 4 RCA connections on the TJA need to be connected to the Aftermarket head unit
No fade from front to back	Only a head unit with 4 RCA outputs will provide fade control
No audio through any speakers	Check the Dip Switches on the side of the TJA interface. Verify they are all "OFF" (Up)