



INSTALLATION INSTRUCTIONS FOR PART 99-5813

APPLICATIONS

LINCOLN

Navigator 2007-up / MKX 2007-2010
MKZ 2007-2009 / Zephyr 2006

Excludes models equipped with factory navigation.

99-5813



KIT FEATURES

- DIN Radio Provision with Pocket
- ISO Mount Radio Provision with Pocket

KIT COMPONENTS

- A) Radio Housing
- B) ISO Brackets
- C) Trim Plate
- D) Radio Housing Brackets (MKZ and Zephyr)
- E) (4) 8X3/8" Phillips Screws

A

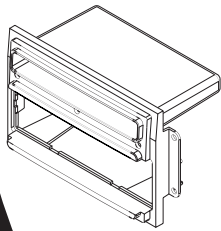

B

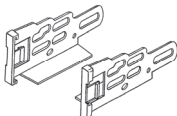

C

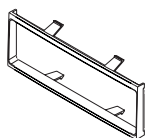

D

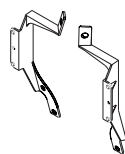

E



WIRING AND ANTENNA CONNECTIONS (Sold Separately)

- XSVI-5520-NAV - Ford Harness 2006-up
- 70-5522 - Ford Sub Harness 2003-up
- 40-CR10 - Chrysler/GM Antenna Adapter 2002-up
- AFDI-THX-01 - Amp Integration w/ THX System (does not retain SYNC)

TOOLS REQUIRED:

- Small Flat Blade Screwdriver
- Panel Removal Tool
- Phillips Screwdriver
- Socket Set



LINCOLN NAVIGATOR 2007-UP

- 1** Disconnect the negative battery terminal to prevent an accidental short circuit.
- 2** Unclip and remove the panel surrounding the shifter. (Figure A)
- 3** Remove (2) 9/32" screws from the bottom of the radio/climate control trim panel. (Figure B)
- 4** Unclip and remove the entire panel surrounding the radio and including the climate controls. (Figure B)
- 5** Remove (4) 9/32" screws securing the radio. Unplug and remove the Radio.

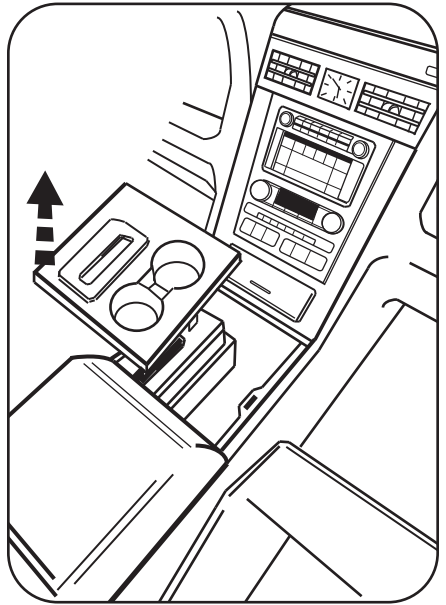
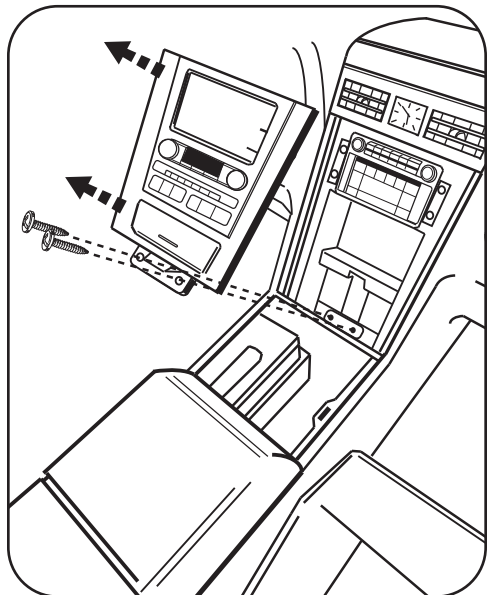
A

B

Continue to kit assembly.

LINCOLN MKX 2007-2010

- 1** Disconnect the negative battery terminal to prevent an accidental short circuit.
- 2** Open center console lid and unclip and remove the center console trim panel surrounding the shifter. (Figure A)
- 3** Remove (2) 9/32" screws from the storage bin then unclip and remove the bin. (Figure B)
- 4** Unclip and remove the center trim panel as one assembly. (Figure C)
- 5** Remove (4) 9/32" screws securing the radio. Unplug and remove the Radio.

Continue to kit assembly.

A

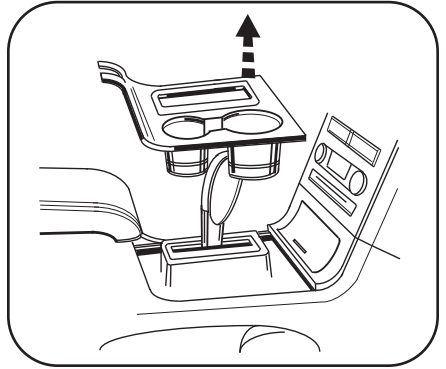

B

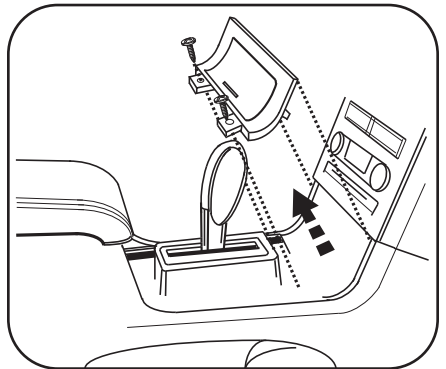

C

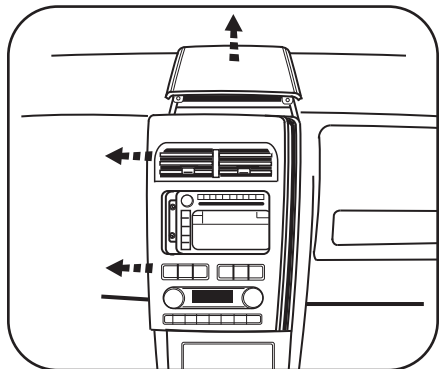

LINCOLN ZEPHYR 2006/LINCOLN MKZ 2007-2009

- 1 Disconnect the negative battery terminal to prevent an accidental short circuit.
- 2 Unclip and remove the top of the center console. (Figure A)
- 3 Open ashtray door and remove ashtray then remove (1) Phillips screw from inside ashtray cavity. Close ashtray door.
- 4 Unclip and remove the climate control and trim panel assembly starting at the bottom edge. (Figure B)
- 5 Open the climate control vents and pull straight outward to remove. (Figure C)

Continued on page 4.

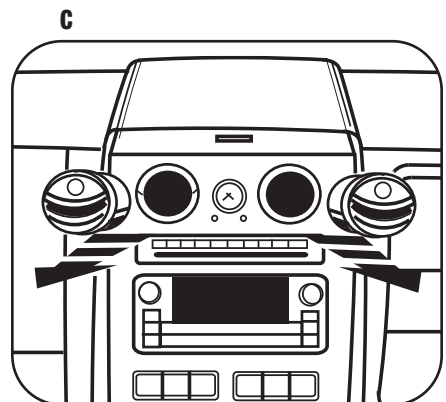
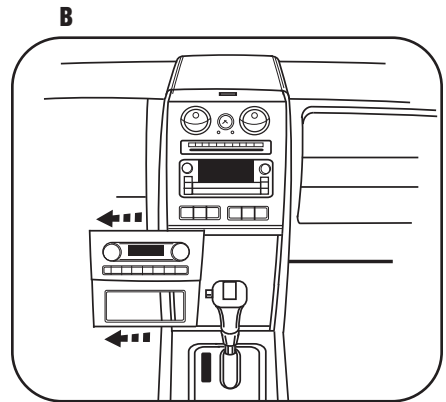
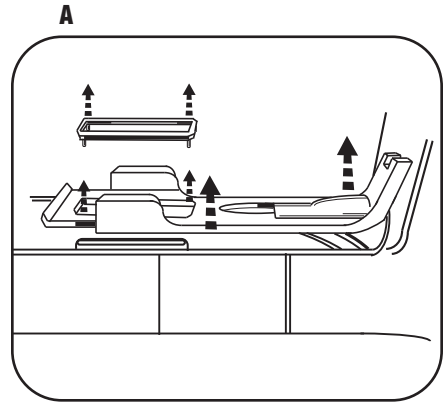

LINCOLN ZEPHYR 2006/LINCOLN MKZ 2007-2009

- 6** Release the (3) clips securing the inner vent cups then pull out to remove cups. (Figure D)
- 7** Remove (2) 10mm screws from the bottom of the radio trim panel assembly and (2) 10mm screws from inside the vents. (Figure E)
- 8** Unclip the radio trim panel/radio assembly. Unplug and remove assembly. (Figure E)
- 9** Remove (4) Phillips screws securing the radio to the trim panel and remove the radio. (Figure F)

Continue to kit assembly.

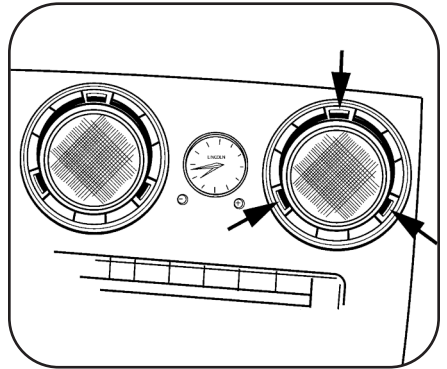
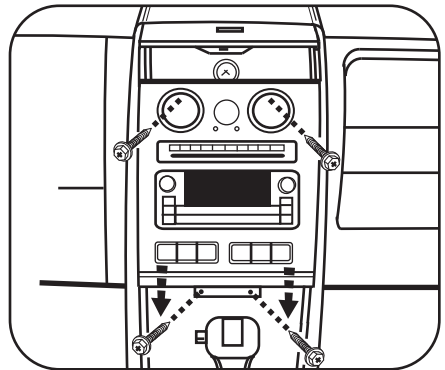
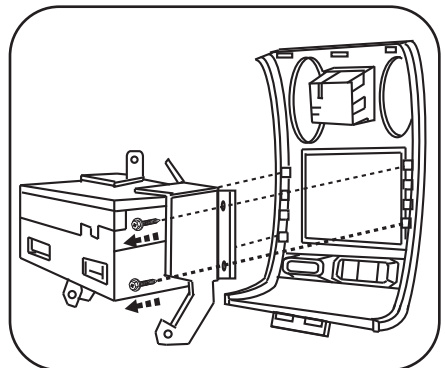
D

E

F

DIN RADIO PROVISION

**Note: Refer also to the instructions included with the aftermarket radio.*

1 2007 MKZ and 2006 Zephyr only:

Attach the corresponding radio housing bracket to the 99-5813 radio housing using the (4) 8X3/8" Phillips screws supplied with kit. (All other models skip to step 2) (Figure A)

2 Slide the DIN cage into the Radio Housing and secure by bending the metal locking outward. (Figure B)

3 Slide the aftermarket radio into the cage until it snaps into place. (Figure C)

Continue to final assembly.

A

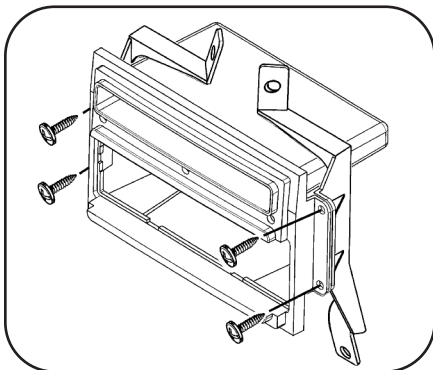

B

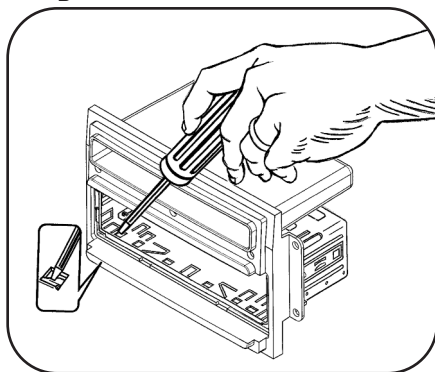

C

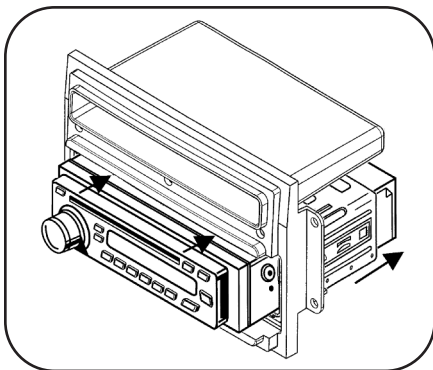

ISO MOUNT RADIO PROVISION

**Note: Refer also to the instructions included with the aftermarket radio.*

1 2007 MKZ and 2006 Zephyr only:

Attach the corresponding radio housing bracket to the 99-5813 radio housing using the (4) 8X3/8" Phillips screws supplied with kit. (All other models skip to step 2) (Figure A)

A

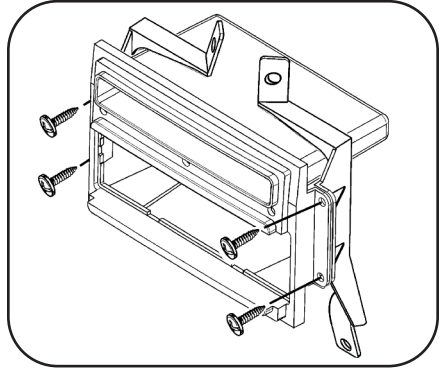

2 Mount the ISO Brackets to the radio using the screws supplied with the radio. (Figure B)

B

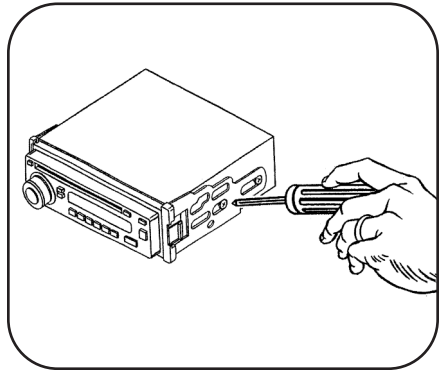

3 Slide the radio into the radio housing until the side clips snap into place. (Figure C)

4 Snap the Trim plate onto the front of the Radio Housing. (Figure C)

C

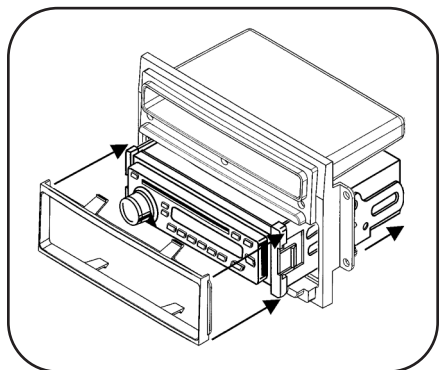

Continue to final assembly.

FINAL ASSEMBLY

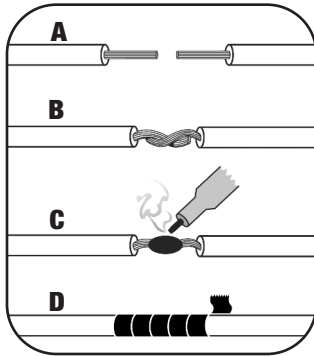

- (A) Strip wire ends back 1/2"**
- B) Twist ends together**
- C) Solder**
- D) Tape**

- 1** Locate the factory wiring harness in the dash. Metra recommends using the proper mating adapter and making connections as shown. (Isolate and individually tape off the ends of any unused wires to prevent electrical short circuit.)
- 2** Re-connect the negative battery terminal and test the unit for proper operation.
- 3** Reassemble radio and dash assemblies in reverse order of disassembly.

FINAL WIRING CONNECTIONS

Make wiring connections using the EIA color code chart shown below and the instructions included with the head unit. Metra recommends making connections as shown below; Strip, Splice, Solder, Tape. Isolate and individually tape off ends of any unused wires to prevent electrical short circuit.

METRA / EIA WIRING CODE

12V Ignition / Acc. Red	Right Front (+) Gray
12V Batt / Memory. Yellow	Right Front (-). Gray/ Black
Ground. Black*	Left Front (+) White
Power Antenna. Blue	Left Front (-). White / Black
Amp Turn-On Blue / White	Right Rear (+) Violet
Amp Ground. Black / White	Right Rear (-). Violet / Black
Illumination Orange	Left Rear (+) Green
Dimmer Orange / White	Left Rear (-). Green / Black

***NOTE:** When a Black wire is not present, ground radio to vehicle chassis.
All colors may not be present on all leads due to manufacturer's specifications.