



## Installation Instructions for 95-7624

### APPLICATIONS

## Nissan Multi-kit 2007-up

(see application list on page 2)

## 95-7624



### KIT FEATURES

- Double DIN radio provision

### KIT COMPONENTS

- A) **Radio housing trim panel, standard** • B) Radio housing trim panel, wide • C) Bracket #1
- D) Bracket #2 • E) Bracket #3 • F) Spacers

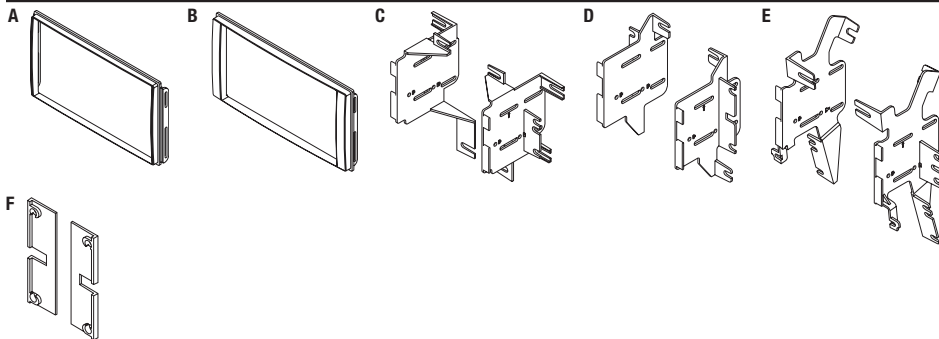

### WIRING & ANTENNA CONNECTIONS (sold separately)

Wiring Harness: • 70-7552 - Nissan 2007-up

Antenna Adapter: • 40-NI12 - Nissan 2007-up

### TOOLS REQUIRED

- Panel removal tool • Phillips screwdriver

**CAUTION:** Metra recommends disconnecting the negative battery terminal before beginning any installation. All accessories, switches, and especially air bag indicator lights must be plugged in before reconnecting the battery or cycling the ignition.

**NOTE:** Refer to the instructions included with the aftermarket radio.

### Nissan Cube 2009-up

1. Remove (2) Phillips screws from the bottom of the a/c trim panel then unclip and remove the panel. (Figure A,B)
2. Remove (2) Phillips screws from the bottom of the radio trim panel then unclip and remove the panel. (Figure C)
3. Remove (4) Phillips screws securing radio to dash to remove.

*Continue to kit assembly*

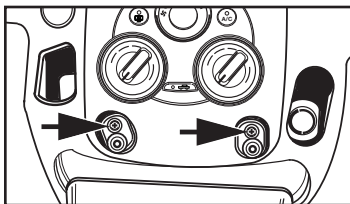

(Figure A)

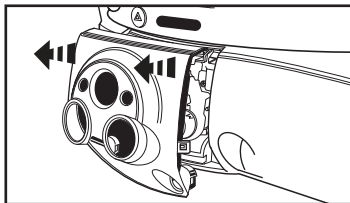

(Figure B)

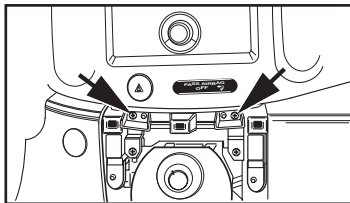

(Figure C)

### Nissan Frontier/Xterra (with 4.3" screen) 2013-up

1. Unclip and remove the trim panel above the radio and climate controls. (Figure A)
2. Remove the (1) Phillips screw under panel and the (2) Phillips screws securing the radio brackets to the sub dash. (Figure B)
3. Unclip and remove the entire panel including the climate controls and factory radio.
4. Remove (4) Torx screws securing the radio to the trim panel. (Figure C, D)

*Continue to kit assembly*

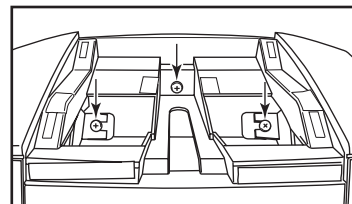

(Figure B)

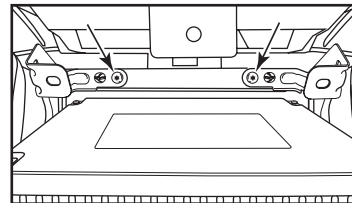

(Figure C)

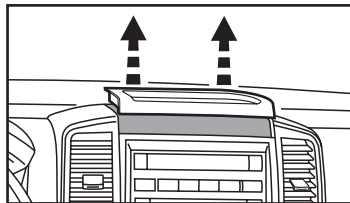

(Figure A)

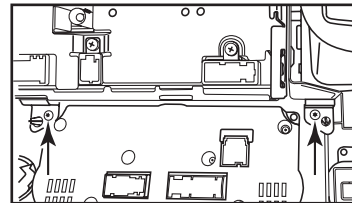

(Figure D)



## 95-7624 Dash Disassembly

### Nissan Juke 2011-up

1. Unclip and remove the climate control panel. (Figure A)
2. Remove (2) Phillips screws securing the radio trim panel. (Figure B)
3. Remove (4) Phillips screws securing radio, unplug and remove radio. (Figure C)

*Continue to kit assembly*

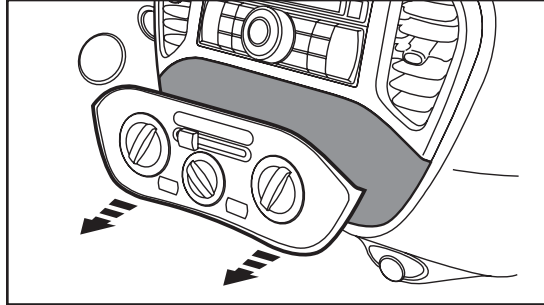

(Figure A)

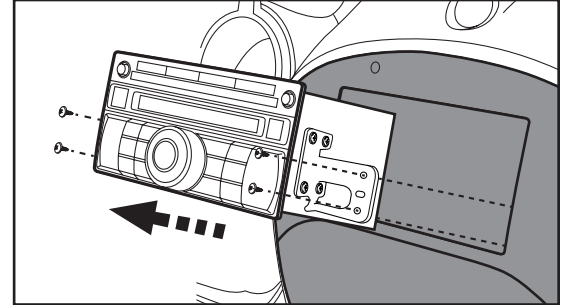

(Figure C)

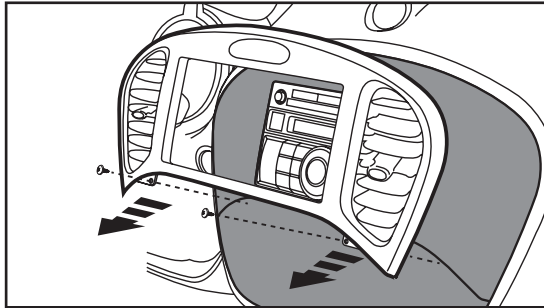

(Figure B)



## 95-7624 Dash Disassembly

### Nissan NV 2012-up

1. Unclip and remove the A/C vent to the right side of the factory radio. (Figure A)
2. Remove the (2) Phillips screws exposed behind vent on radio trim panel. (Figure B)
3. Unclip and remove the left A/C vent next to the instrument display. (Figure C)
4. Unclip the top edge of the knee bolster panel below the steering column and let hang. (Figure D)

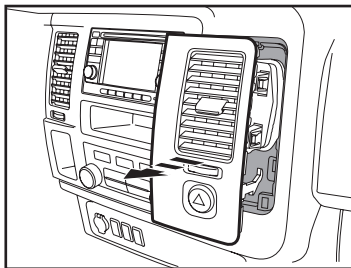

(Figure A)

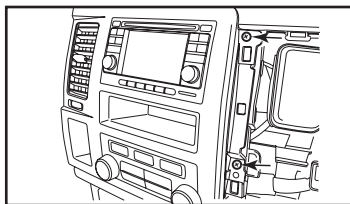

(Figure B)

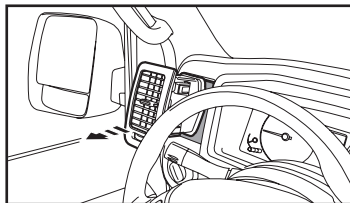

(Figure C)

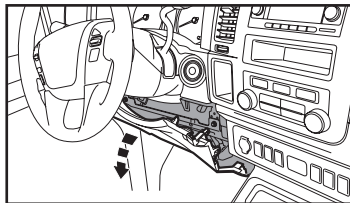

(Figure D)

5. Unclip the circle trim around the key cylinder.
6. Unclip and remove the gauge cluster trim panel. (Figure E)
7. Remove (2) Phillips screws exposed behind the panel on the left side of the radio trim panel. (Figure F)
8. Unclip and remove the trim panel surrounding the factory radio. (Figure G)
9. Remove (4) Phillips screws securing the radio. (Figure H)

*Continue to kit assembly*

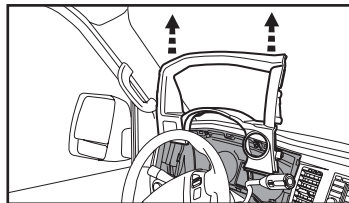

(Figure E)

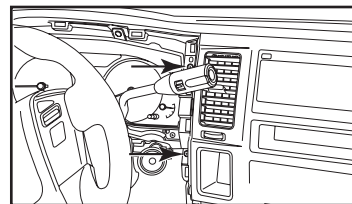

(Figure F)

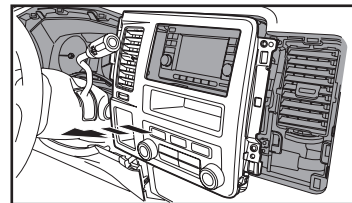

(Figure G)

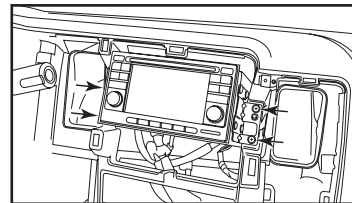

(Figure H)



## 95-7624 Dash Disassembly

### Chevrolet City Express 2015-up, Nissan NV200 2013-up

1. Unclip and remove the recirculate/fresh slide button. (Figure A)
2. Unclip and remove the entire panel surrounding the radio including the a/c vents. (Figure B)
3. Remove (4) Phillips screws securing the radio. (Figure C)

*Continue to kit assembly*

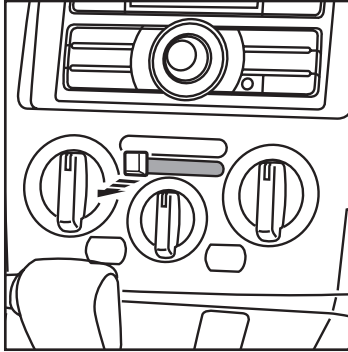

(Figure A)

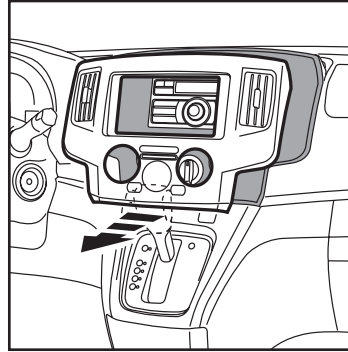

(Figure B)

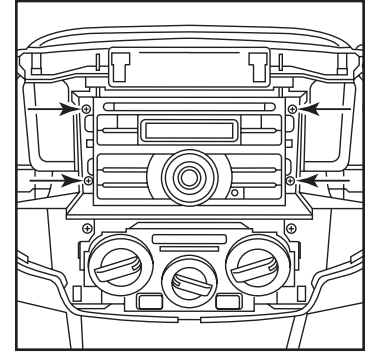

(Figure C)

### Nissan Quest (without NAV or rear seat entertainment) 2011-up

1. Unclip and remove the panels from the bottom left and right side of the center console. (Figure A)

2. Remove (2) clips per side exposed behind lower panels. (Figure B)

3. Unclip and pull center console toward rear of vehicle.

**Note: You do not have to fully remove console.** (Figure C)

4. Unclip and remove the trim panel to the left of the shifter housing the start/stop button. (Figure D)

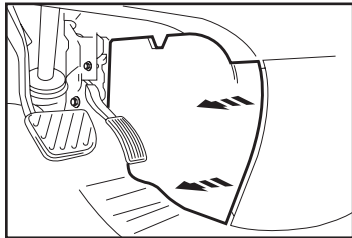

(Figure A)

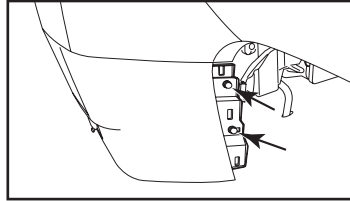

(Figure B)

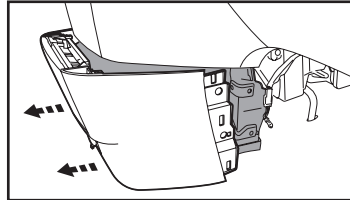

(Figure C)

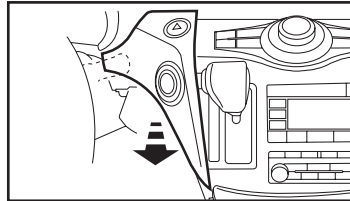

(Figure D)

5. Unclip and remove the panel on the end of the passenger side of the dash. (Figure E)

6. Remove (1) Phillips screw from the trim panel above the glove box then unclip and remove the panel. (Figure F)

*Continued on next page*

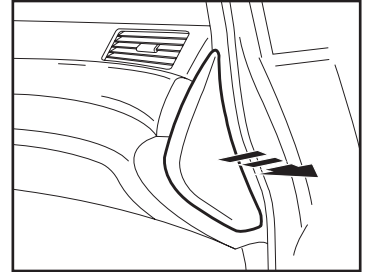

(Figure E)

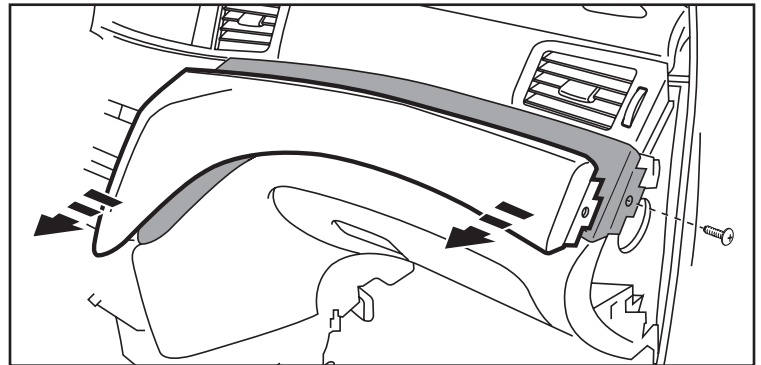

(Figure F)

**Nissan Quest** (without NAV or rear seat entertainment) **2011-up**

7. Remove (1) Phillips screw from the cup holder panel then unclip and remove the panel. (Figure G)

8. Remove (2) Phillips screws from the a/c control panel and unclip and let hang. (Figure H)

9. Remove (2) Phillips screws from the bottom of the radio trim panel including the vents then unclip and remove the panel. (Figure H)

10. Remove (4) Phillips screws securing the radio. (Figure I)

*Continue to Kit Assembly*

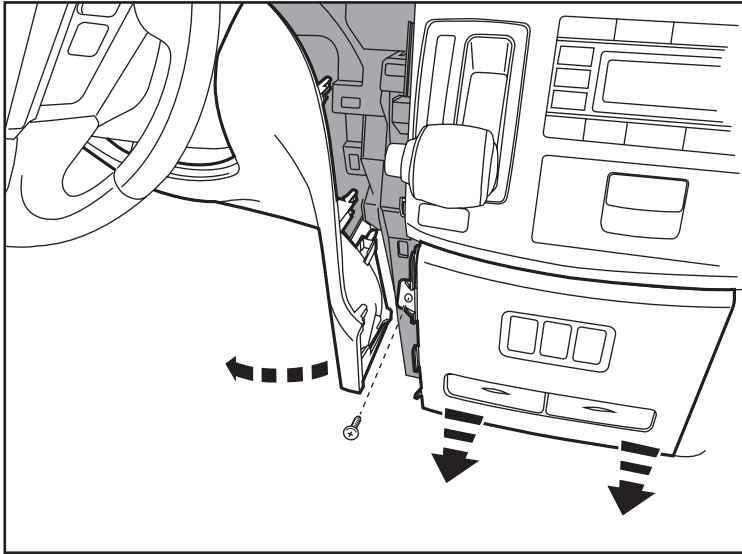

(Figure G)

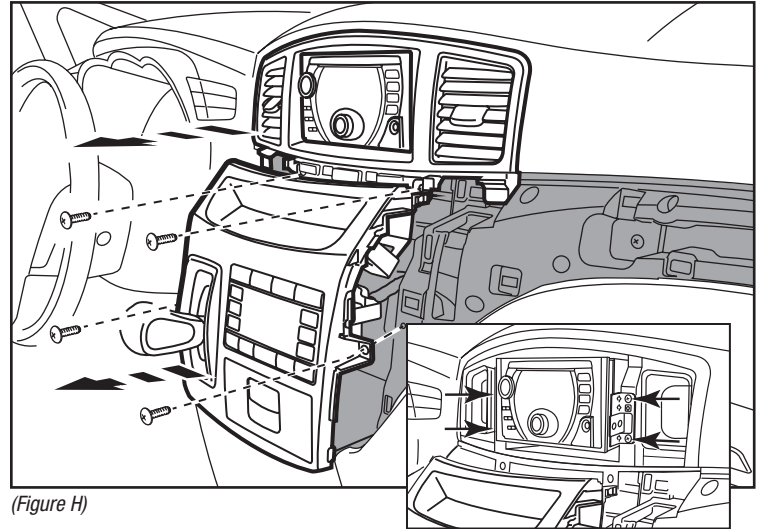

(Figure H)

(Figure I)



## 95-7624 Dash Disassembly

### Rogue 2011-2013, Rogue Select 2014

- 1. If equipped with center speaker:** Unclip and remove the grille then remove (4) Phillips screws to remove the speaker. (Figure A)
- 2.** Unclip and remove the panel below the radio including the a/c controls. (Figure B)
- 3.** Unclip the radio trim including the a/c vents then unplug the hazard switch and remove the panel. (Figure C)
- 4.** Remove (4) Phillips screws securing the radio. (Figure D)  
*Continue to kit assembly*

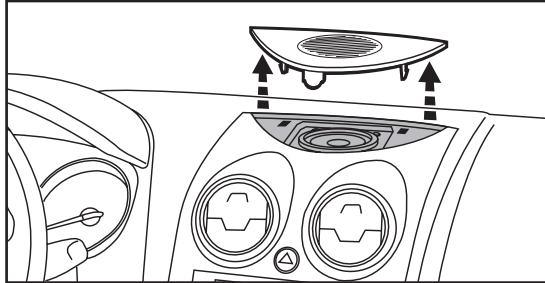

(Figure A)

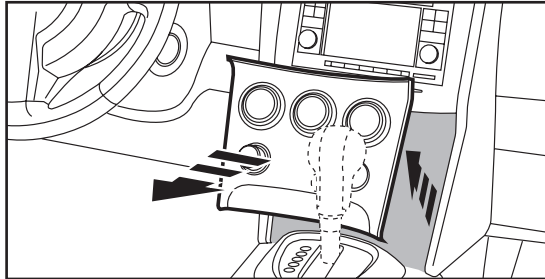

(Figure B)

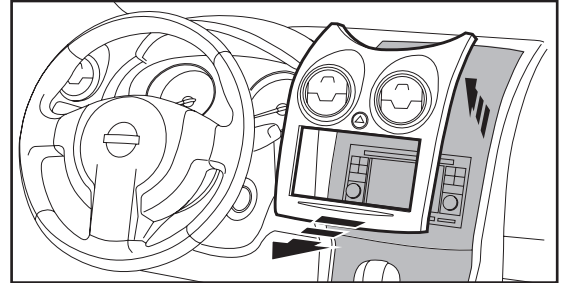

(Figure C)

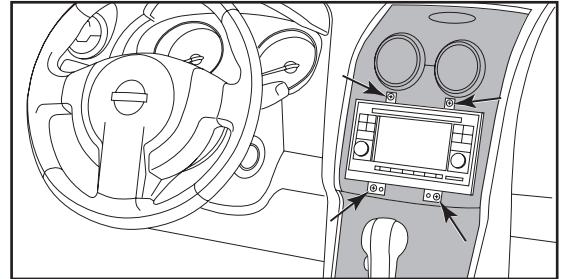

(Figure D)



### Nissan Titan (with 4.3" screen) 2013-up

1. Unclip the entire dash panel including the climate controls. Unplug and remove the panel. (Figure A)
2. Remove (4) Phillips screws securing the radio. Unplug and remove the chassis. (Figure B)

*Continue to kit assembly*

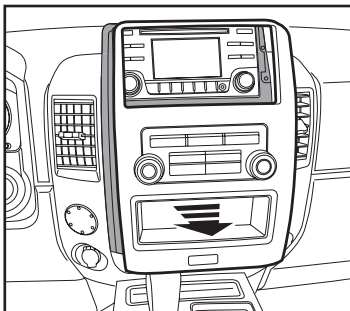

(Figure A)

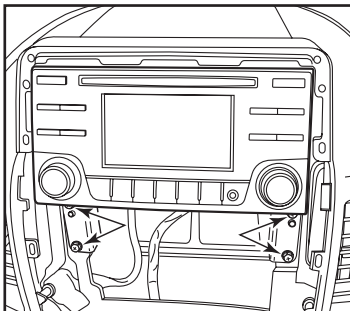

(Figure B)

### Nissan Versa 2007-2011

1. Unclip and remove the panel above the radio. (Figure A, B)
2. Remove (2) Phillips screws securing the radio trim panel then unclip and remove the entire panel surrounding the radio and A/C controls. (Figure C)
3. Remove (4) Phillips screws securing radio, unplug and remove radio. (Figure D)

*Continue to kit assembly*

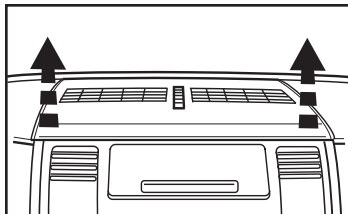

(Figure A)

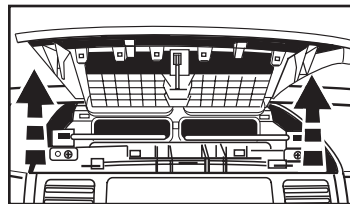

(Figure B)

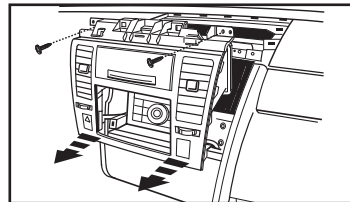

(Figure C)

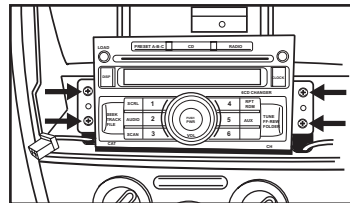

(Figure D)



## 95-7624 Dash Disassembly

### Versa 2012-up, Versa Note 2014-up

1. Unclip and remove the entire panel surrounding the radio including the A/C vents. (Figure A)
2. Remove (4) Phillips screws securing the radio. (Figure B)

*Continue to kit assembly*

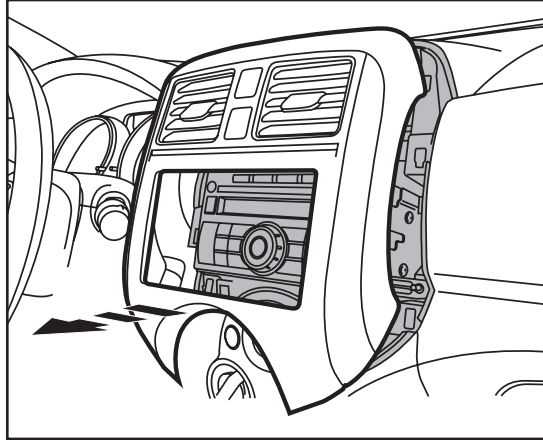

(Figure A)

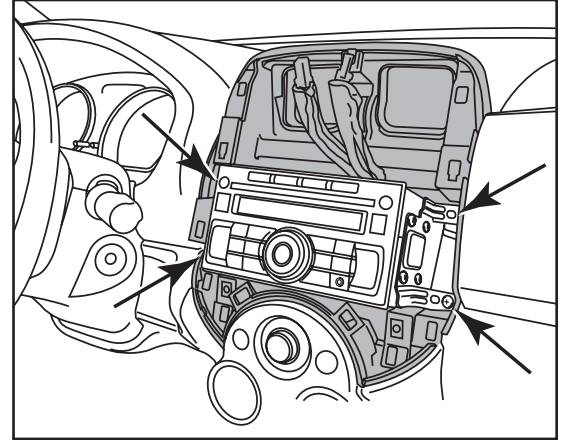

(Figure B)



## 95-7624 Kit Assembly

### Radio housing trim panel usage

Vehicle	Trim panel
Cube 2009-up	Standard
Frontier (with 4.3" screen) 2013-up	Wide
Juke 2011-2014	Standard
Juke 2015-up	Wide
NV 2012-up	Standard
NV200 2013-up, Chevrolet City Express 2015-up (both without NAV)	Standard
NV200 2013-up, Chevrolet City Express 2015-up (both with NAV)	Wide
Quest (without NAV or rear seat entertainment) 2011-2012	Standard
Quest (without NAV or rear seat entertainment) 2013-up	Wide
Rogue Select (with lower model radio) 2014	Standard
Rogue Select (with upper model radio) 2014	Wide
Rogue S (with Special Edition Package) 2012-2013	Wide
Rogue SV 2012-2013	Wide
Rogue S and SV (with SL Package) 2003-2007	Standard
Rogue 2011	Standard
Titan (with 4.3" screen) 2013-up	Wide
Versa 2007-2011	Standard
Versa 2012-2013	Standard
Versa S, S+ and SV (without options) 2014	Standard
Versa Note 2014	Wide
Versa SL and SV (with Convenience Package) 2014	Wide
Versa and Versa Note (all models) 2015-up	Wide
Xterra (with 4.3" screen) 2013-up	Wide

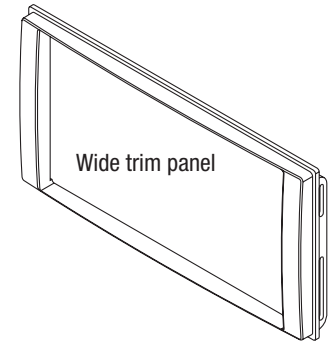
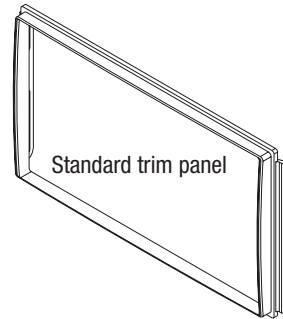



## 95-7624 Kit Assembly

### Bracket #1 tab layout

Bracket #	Tab	Vehicle
1	A	Versa 2012-up
1	A	Versa Note 2014-up
1	B	Rogue 2011-2013
1	B	Rogue Select 2014
1	C	NV 2012-up
1	C	Quest (without NAV or rear seat entertainment) 2011-up

**Note:** It may be necessary to remove all unneeded tabs from the brackets for certain applications. Depending on the application it may also be necessary to trim the entire bracket as close as possible to the radio mounting locations on the brackets.

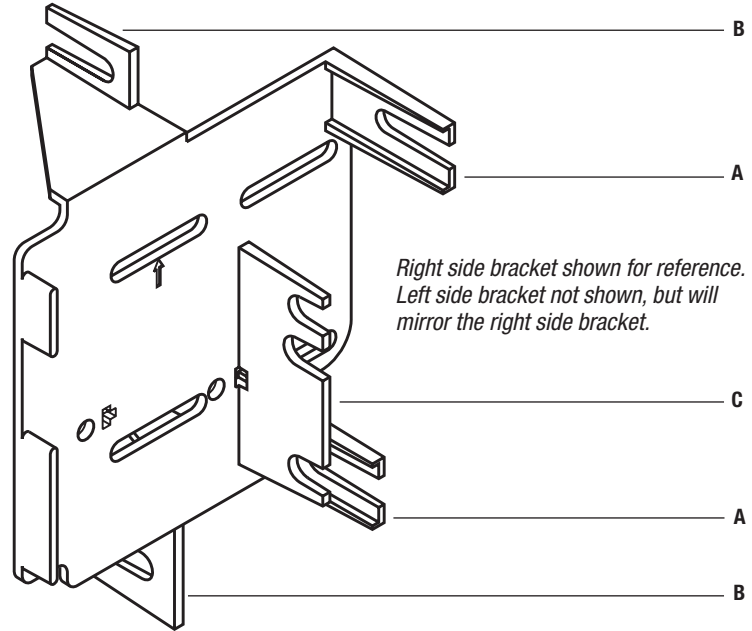



## 95-7624 Kit Assembly

### Bracket #2 tab layout

Bracket #	Tab	Vehicle
2	E	Chevrolet City Express 2015-up
2	D	Nissan Juke 2011-up
2	E	Nissan NV200 2013-up
2	E	Nissan Cube (use spacers) 2009-up

**Note:** It may be necessary to remove all unneeded tabs from the brackets for certain applications. Depending on the application it may also be necessary to trim the entire bracket as close as possible to the radio mounting locations on the brackets.

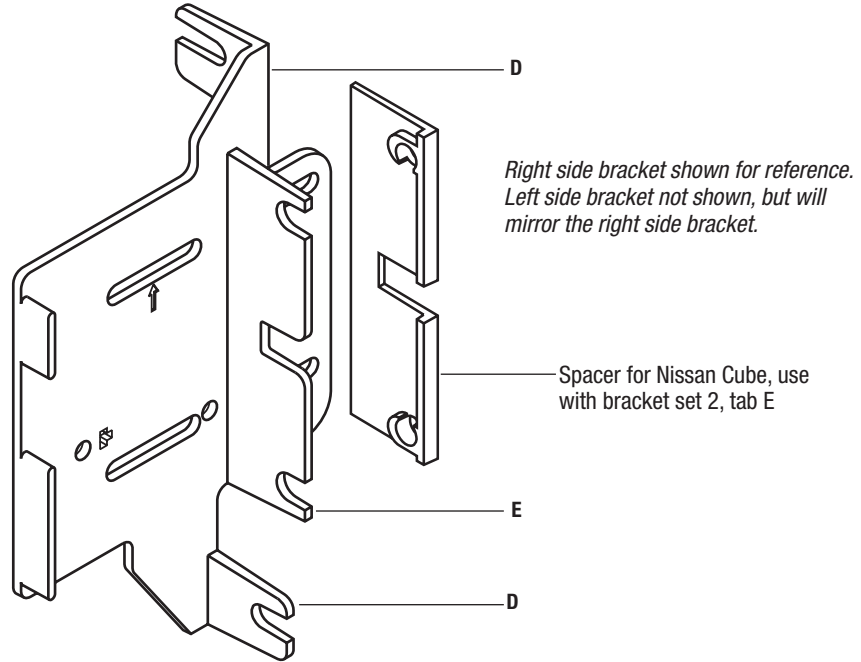



## 95-7624 Kit Assembly

### Bracket #3 tab layout

Bracket #	Tab	Vehicle
3	F	Frontier/Xterra (with 4.3" screen) 2013-up
3	G	Titan 2013-up
3	H	Versa 2007-2011

**Note:** It may be necessary to remove all unneeded tabs from the brackets for certain applications. Depending on the application it may also be necessary to trim the entire bracket as close as possible to the radio mounting locations on the brackets.

1. Cut and remove the shaded area of the brackets for the 2013-up Frontier and Xterra. (Figure A)
2. Cut and remove the shaded area of the brackets for the 2013-up Titan. (Figure A)

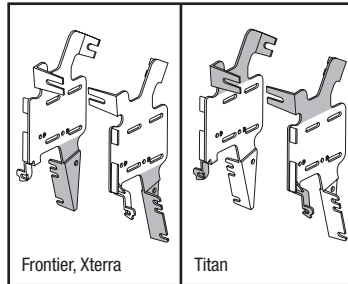

(Figure A)

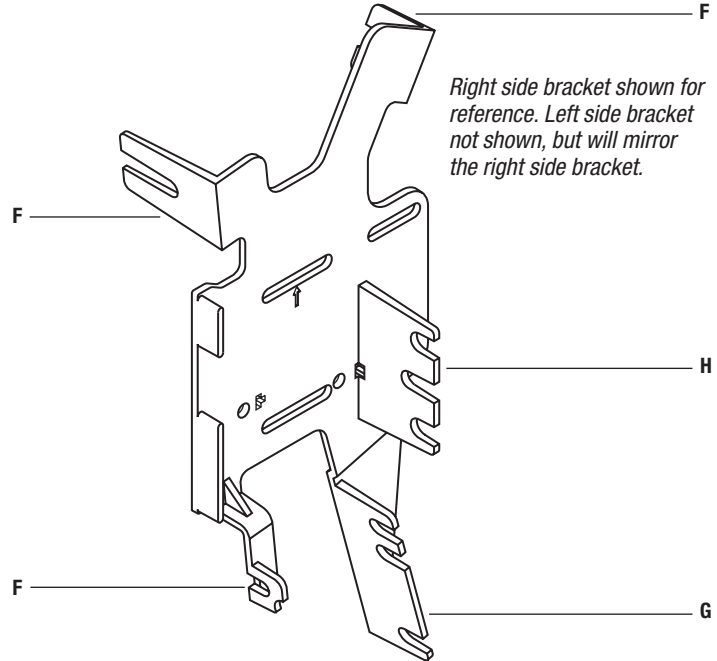



## 95-7624 Kit Assembly

### Kit Assembly

#### Double DIN radio provision

1. Attach your corresponding bracket to the radio housing trim panel. *(Bracket #2 with the standard radio trim panel shown) (Figure A)*
2. Slide the radio into the assembly and secure with screws supplied with the radio. (Figure B)
3. Locate the factory wiring harness and antenna plug in the dash. Metra recommends using the proper mating adapters from Metra and/or AXCESS.
4. Mount the new radio assembly into the dash and reassemble dash in reverse order of disassembly.

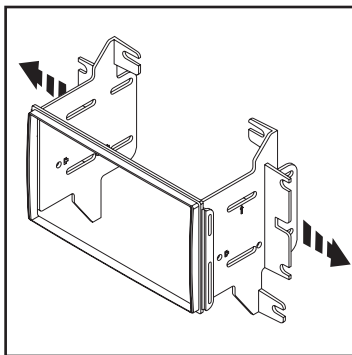

(Figure A)

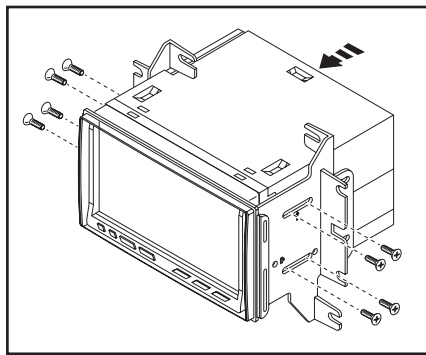

(Figure B)