



## INSTALLATION INSTRUCTIONS FOR PART 95-7360B

### APPLICATIONS

## Kia Soul 2014-up

(Models without Navigation only)

## 95-7360B



### KIT FEATURES

- ISO DDIN radio provision
- *Painted matte black to match factory finish*

### KIT COMPONENTS

- A) **Radio housing trim panel** • B) Brackets

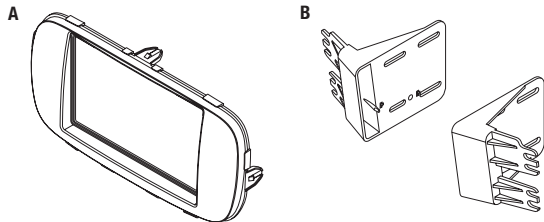

### WIRING & ANTENNA CONNECTIONS (sold separately)

Wiring Harness: • 70-7304 harness or HYBL-04 interface

Antenna Adapter: • Not required

### TOOLS REQUIRED

- Panel removal tool • Phillips screwdriver

**CAUTION:** Metra recommends disconnecting the negative battery terminal before beginning any installation. All accessories, switches, and especially air bag indicator lights must be plugged in before reconnecting the battery or cycling the ignition.

**NOTE:** Refer to the instructions included with the aftermarket radio.



95-7360B

## Dash Disassembly

1. Unsnap and remove the panel from around the factory radio. (Figure A)
2. Remove four screws and remove radio. (Figure B)

*Continue to kit assembly*

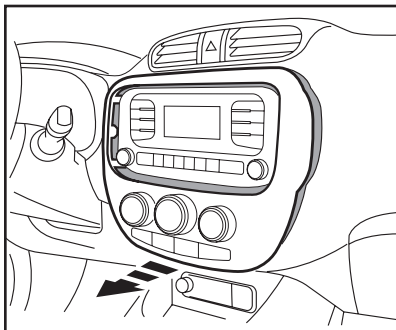

(Figure A)

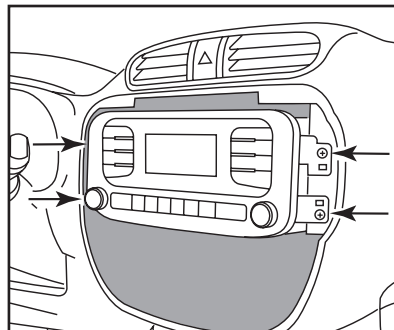

(Figure B)



95-7360B

## Kit Assembly

### ISO DDIN radio provision

1. Break the small locating pin from the inside surface of each bracket. (Figure A)
2. Attach the radio to the brackets with the screws supplied with the radio. (Figure B)
3. Locate the factory wiring harness and antenna plug in the dash. Metra recommends using the proper mating adapters from Metra and/or AXCESS.
4. Mount the new radio assembly into the dash, snap the Metra radio trim panel over the radio assembly, and reassemble dash in reverse order of disassembly.

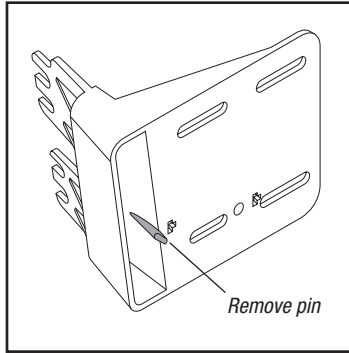

(Figure A)

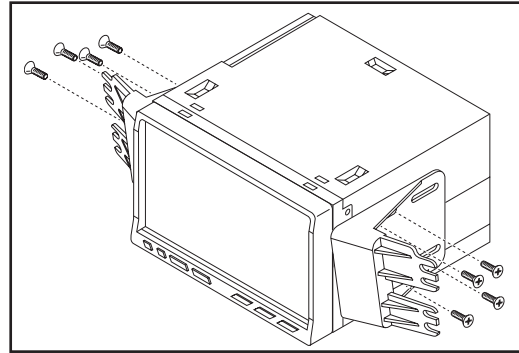

(Figure B)



## INSTALLATION INSTRUCTIONS FOR PART 95-7360B



REV. 7/3/2014 INST95-7360B



### KNOWLEDGE IS POWER

Enhance your installation and fabrication skills by enrolling in the most recognized and respected mobile electronics school in our industry. Log onto [www.installerinstitute.com](http://www.installerinstitute.com) or call 800-354-6782 for more information and take steps toward a better tomorrow.



**Metra recommends MECP certified technicians**



## INSTRUCCIONES DE INSTALACIÓN PARA LA PIEZA 95-7360B

### APLICACIONES

## Kia Soul 2014 y mas

(Únicamente modelos con navegación)

## 95-7360B



### CARACTERÍSTICAS DEL KIT

- Provisión de radio doble DIN
- Pintado negro mate

### COMPONENTES DEL KIT

- A) Panel de moldura para radio
- B) Soportes

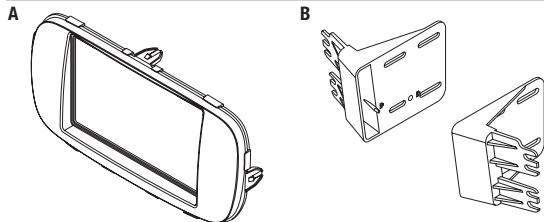

### CABLEADO Y CONEXIONES DE ANTENA (se venden por separado)

Arnés de cables: • Arnés 70-7304 o interfase HYBL-04

Adaptador de antena: • No se requiere

### Índice

#### Desmontaje del tablero

– Kia Soul 2014 y mas ..... 2

#### Ensamble del kit

– Provisión de radio doble DIN..... 3

### HERRAMIENTAS REQUERIDAS

- Herramienta para quitar paneles
- Destornillador Phillips

**PRECAUCIÓN:** Metra recomienda desconectar el terminal negativo de la batería antes de comenzar cualquier instalación. Todos los accesorios, interruptores y, especialmente, las luces indicadoras de airbag deben estar enchufados antes de volver a conectar la batería o comenzar el ciclo de ignición.

**Nota:** Remítase a las instrucciones incluidas con el radio de posventa.

## Desmontaje del tablero

1. Suelte a presión y quite el panel de alrededor del radio de fábrica. (Figura A)
2. Quite los (4) tornillos y quite el radio. (Figura B)

*Continúe kit de montaje*

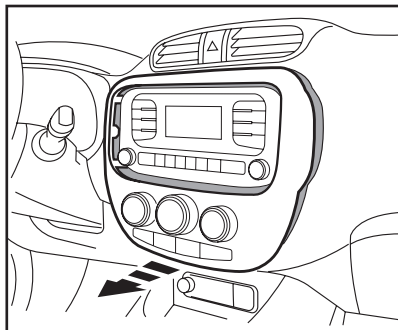

(Figura A)

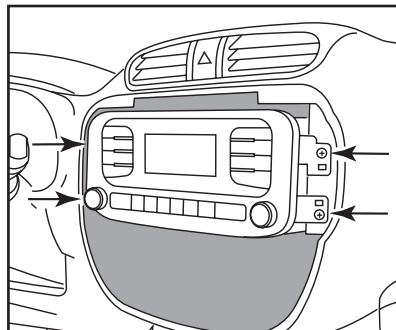

(Figura B)

## Ensamble del kit

### Provisión de radio ISO DDIN

1. Quiebre el pequeño pin que está en la superficie interior de cada soporte. (Figura A)
2. Sujete el radio a los soportes con los tornillos suministrados con el radio. (Figura B)
3. Ubique el arnés de cableado de fábrica y el conector de la antena en el tablero. Metra recomienda el uso de los adaptadores adecuados de acoplamiento de Metra y/o AXXESS.
4. Monte el nuevo conjunto del radio en el tablero, coloque a presión el panel de la moldura del radio Metra sobre el conjunto del radio y vuelva a armar el tablero al revés de como lo desarmó.

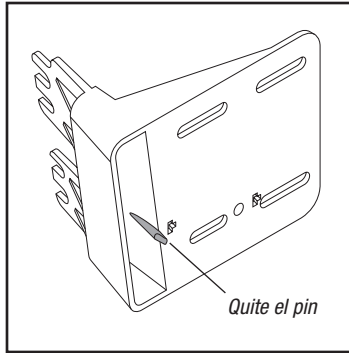

(Figura A)

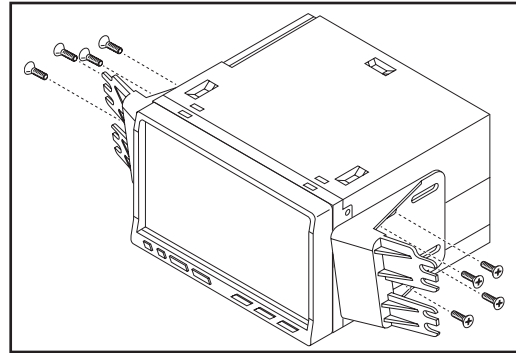

(Figura B)