



INSTALLATION INSTRUCTIONS FOR PART 95-3310B

APPLICATIONS

Chevrolet Traverse 2013-up, GMC Acadia 2013-up, Buick Enclave 2013-up 95-3310B

KIT FEATURES

- DDIN Radio provision
- *Painted black*



KIT COMPONENTS

- A) **Radio Trim Panel** • B) Radio Brackets

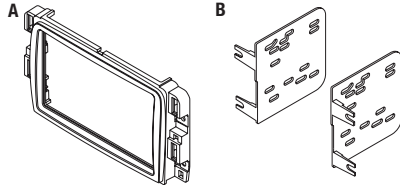

WIRING & ANTENNA CONNECTIONS (sold separately)

Wiring Harness: • See www.metraonline.com for harness information

Antenna Adapter: • 40-CR10 Chrysler/GM antenna adapter 2002-up

TOOLS REQUIRED

- Panel removal tool • Phillips screwdriver • Socket Wrench

CAUTION: Metra recommends disconnecting the negative battery terminal before beginning any installation. All accessories, switches, and especially air bag indicator lights must be plugged in before reconnecting the battery or cycling the ignition.

NOTE: Refer to the instructions included with the aftermarket radio.



95-33108

Dash Disassembly

1. Unclip and remove the radio trim panel including the climate controls, then unplug the climate controls and remove the panel. (Figure A)
2. Remove (2) 9/32" Screws securing the hazard switch assembly. (Figure B)
3. Remove (4) 9/32" Screws securing the radio then unplug and remove the radio. (Figure C)

Continue to kit assembly

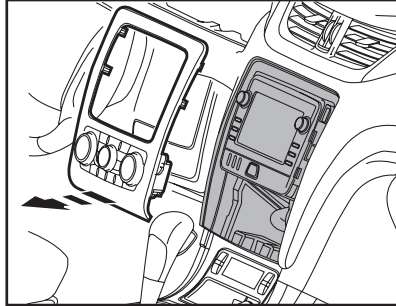

(Figure A)

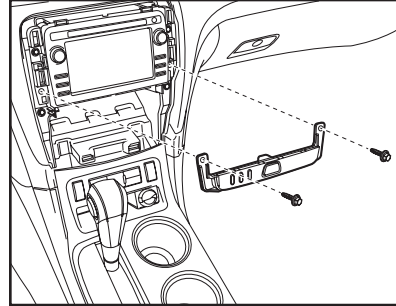

(Figure B)

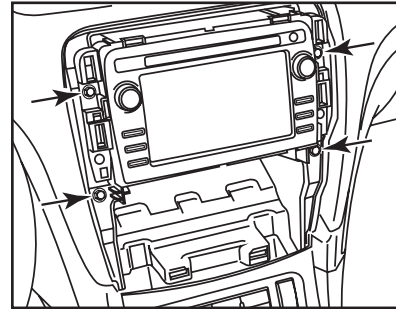

(Figure C)



95-33108

Kit Assembly

Double DIN radio provision

1. Slide the radio brackets into the trim plate aligning the holes in the trim plate to the clips on the brackets. (Figure A)
2. Slide the Double DIN radio into the bracket/trim plate assembly and secure the Double DIN radio to the assembly using the screws supplied with the radio (Figure B)
3. Locate the factory wiring harness and antenna plug in the dash. Metra recommends using the proper mating adapters from Metra and/or AXXESS.
4. Mount the new radio assembly into the dash and reassemble dash in reverse order of disassembly.

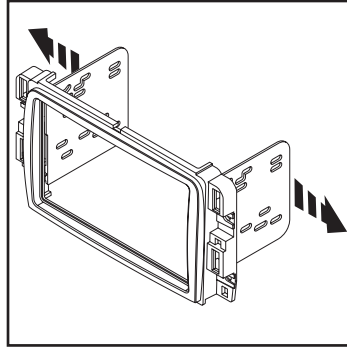

(Figure A)

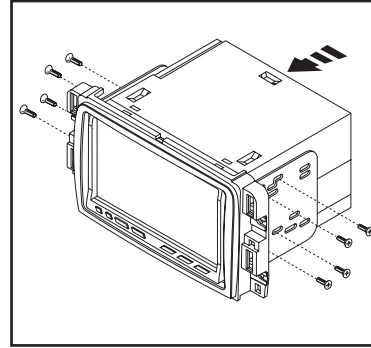

(Figure B)