



## TERMS & CONDITIONS

**TERMS** C.O.D. or Credit Card. Axles and special built products require a deposit as do items requiring shipment by methods other than UPS. Credit Card usage will expedite order processing. We accept money orders, certified checks or official bank checks only for C.O.D. orders. UPS will no longer accept cash for C.O.D. shipments. If a C.O.D. delivery is refused we will not ship C.O.D. on future orders; prepayment will be required. We accept Visa, Master Card, American Express and Discover. All credit card orders must be shipped to the billing address of the card only.

**WARNING** Modification of your car's chassis or driveline to enhance performance with the parts identified in this catalog may create a dangerous condition which could cause serious bodily injury. The buyer hereby expressly assumes all risks associated with any such modifications.

**SPECIFICATIONS** Non-critical specifications are subject to change without notice.

## CONTENTS

8.8 Ford Components	34
9" Ford Rears and Components	28-33
A-Arm Front End Materials Kit	76
Alignment Bar, Rear Housing and Chassis	58, 83
Anti-Roll Assemblies	77
Axles, Flange & Truck forged steel (rear)	5-6, 10
Axle Stud kits	8-9
Bearings, Rear Axle	5-6
Brake System Components	63-64
Brakes, Front, Steel	59-60
Brakes, Pro-Street	7
Brakes, Rear, Steel and Carbon Fiber	61
Brake Levers/Pedal	78
Chassis Blueprints	87-88
Chassis Tabs	81
Chromoly Tubing, Plate, and Tube Bends	82
Chevrolet 12-bolt Rears and Components	37-39
Computer Pickup Assemblies	71
Couplers, Solid Splined Driveshafts, Disconnects	73-74, 85
CV Axle Shafts and Components	11-12
Dana 60 Components	35-36
Driveshafts, steel, aluminum & carbon fiber	65-67
Driveshaft Internal Slip, Mustang & Hellcat	84
Dzus Buttons, Tabs, Springs	81
Filler Caps and Bungs	56
Front Axles and Torsion Assemblies	76-77
Full Floater Assemblies	55
Gears, Ring and Pinions	17-23
Gear Oil	23
Gibbs Corrosion Inhibitor	25
Housing Ends and Retainers	57
Housing Street Weld on End Kits	6
Honda Front Wheel Drive	12
Installation Kits for Gear Sets	17-22
Lug Nuts and Washers	9
Labor Operations	52,59
Master Cylinders	64
MasterLine Components	86
Modular Axle Housings and Components	42-54
Mopar Components (8 3/4)	40
Morse Cables and Accessories	79
Motor Plates and Clamps	81
Olds /Pontiac Components	41
Off Road Driveline	70
Pinion Depth Checker	24
Pinion Supports	29
Posi-traction and Locker Units	34,35
Promotional Items	88
Rear End Replacement Caps	32, 34, 36, 39, 40, 41
Rod Ends, Threaded Clevises and Jam Nuts	79-80
Spindles, front	76
Spools, steel and aluminum	11,14,15,30,34,35,38,40,41,86
Steering Boxes	76
Steering Wheels and Q/R Hubs	75
Torsion and Anti-Roll Assemblies	76-77
Thirdmembers Assemblies	25-27
Tools	9,23,24,58,81,83
Tube Adapters	80
Weld-In Clevises	80
Yokes, transmission and pinion	67-70

# QUESTIONS & ANSWERS

## 1. ARE ALL AXLES WITH SIMILAR SPLINE COUNTS INTERCHANGEABLE?

No! For example, an OEM 35-spline Dana axle and a special MW 35 spline axle are not interchangeable because the MW spline features a 45-degree pressure angle, which differs from stock Dana 30-degree configuration. Mark Williams does, however, offer Hi-Torque forged steel axles with OEM type splines. Please read additional spline text on page 3.

## 2. WHY DO MW HI-TORQUE AXLES HAVE A REDUCED DIAMETER AFTER THE SPLINE?

In order for a splined shaft to carry its maximum torsional load it is necessary to have a working shaft diameter smaller than the major spline diameter. The reduced section after the spline works in the same manner as a torsion bar allowing the rotational wind up to occur over a longer area. This prevents the axle from experiencing permanent set. Axles that are not undercut will twist at the end of the spline engagement and eventually fail at this point.

## 3. WHAT TYPE OF AXLE RETENTION IS REQUIRED?

Most race-sanctioning organizations require some type of positive retention. The OEM C-clip does not meet these requirements. Accordingly, MW offers a special C-clip eliminator kit to provide the necessary retention. However, it is advisable to change to weld-on housing ends if your plans call for narrowing the axle housing. MW can supply weld-on ends, with oversize bearings and retainers for most popular brake applications.

## 4. WHY IS THE SPLINE AREA ON MW AXLES SHORTER THAN OTHERS?

Most manufacturers do not make custom axles for each order. Instead, they gang-run axles in certain lengths and make them with very long splines. When an order comes in, they simply cut off the excess spline. MW axles are manufactured to the correct length to insure 100% engagement in the spool spline. Excessive unused spline length reduces the torsional capability of an axle.

## 5. SHOULD I GET 35 OR 40-SPLINE AXLE-SPOOL COMBINATION?

For many applications the 1.500" diameter 35-tooth special MW spline axles are more than adequate. For "bulletproof" reliability there's no question the 40-spline setup is preferred. We've found

these big 1.708" diameter axles to also prolong housing life and wheel alignment because of their ability to handle increased torsion as well as bending (toe in) loads. If your rear end will accept a 40 spline spool we recommend using it.

## 6. WHY ARE MW AXLES SHORTER THAN MY "OLD" ONES?

This question is often asked by customers who replace an OEM axle/differential or another brand axle/spool combination with a MW setup. The reason is that the spline location in most MW spools is positioned further outboard to allow a larger spline. As a result, the axles can be shorter and as an added bonus are slightly lighter.

## 7. IS A 3-1/4" BORE 9" FORD CASE NEEDED TO RUN 35 SPLINE AXLES?

Not with MW axles. Unlike our competitors, we manufacture a 35 spline spool that fits in the stock 9" Ford cases (2.893" or 3.062" bore). MW spools have been designed to position the splines at the outboard end of the spool on both sides. This is an exclusive MW feature that has been used for over 30 years. This same feature applies to 10 and 12-bolt G.M. spools which are also limited to stock carrier bearing sizes.

## 8. WHY DO I SEE AXLES ADVERTISED AS "ALLOY AXLES" SO CHEAP?

These axles are actually produced by an OEM axle forging company whose main business is making axles for the truck and construction industry. The material used is a carbon steel, common to OEM axles. It is not usually regarded as an alloy steel as advertised. The manufacturer produces the axle blank and the advertiser cuts the axle to length and splines it. These axles are made from the same material as stock axles and receive the same heat treatment. The only difference is that they are available in shorter lengths and with different splines.

## 9. WHICH HOUSING END SHOULD I USE?

We recommend choosing the ends to match the brakes you want to use. If you are going to use disc brakes we recommend the symmetrical housing ends. This will allow the best designed Disc Brake kit and eliminates confusion about wheel stand outs. We do not recommend using the small Ford housing ends. The wheel bearing is too small and delicate.



# DETAILS MAKE THE DIFFERENCE

**Axle Manufacturing** The ability to produce a quality racing axle requires more than meets the eye. We have learned from our 50+ years that the improvement process never stops. We are constantly making improvements to assure that every axle produced incorporates the latest technology. Axles are our primary product and as such we have a considerable investment in dedicated CNC and other equipment for the production of race axles. In addition, Mark Williams Enterprises is the only company in the racing axle business that has both induction and thru hardening in-house heat treating capability. This allows us total control over the most important operation in the manufacturing process. One example of the details that make MW "Hi-Torque" axles superior is the CNC grinding of the axle flange face and bearing seat/shoulder with a freshly-dressed true radius grinding wheel. The radius at the bearing shoulder is the most critical part of an axle because it's the focal point of the bending moment (where the most force is concentrated). To insure the accuracy of this radius the grinding wheel is dressed prior to grinding each axle with CNC precision. By dressing the wheel for each axle it also eliminates the chance of imbedded contaminants causing friction-induced surface cracks. MW's extra efforts in manufacturing pay huge dividends in reliability.

**AXLES SPLINES** A key factor to consider when purchasing axles is the axle spline. Naturally, if the axles you are purchasing are to be mated to existing components you will need a similar replacement spline. Accordingly, MW manufactures axles with all popular spline configurations, including Dana 60, 12-bolt Chevy, 9" Ford, etc., plus splines compatible with after-market products from other manufacturers. If you have a choice of splines, as in the case of a new axle/spool combination, it is highly recommended that you utilize MW's special 35 or 40 spline. This is especially important since locked (spool-equipped) rear ends are subject to as much as twice the torsion load of standard open-type differentials. For most applications the MW 35 spline with a 1.500" diameter and 45 degree pressure angle is adequate. In comparative shear strength, the MW 35 spline is 61% stronger than the Chevrolet 12-bolt with 30 spline, 45% stronger than a 9" Ford with 31 spline, and even 3% stronger than the Dana 35 spline which has a 30 degree pressure angle. These calculations are based on the physical dimensions of the spline itself, and do not take into consideration the extra strength benefits of MW's Nickel Chromium Molybdenum alloy forging and austempering heat treating process. For those applications requiring maximum strength axles MW offers a big 1.708" diameter 45 degree pressure angle 40-tooth spline that is 51% stronger than the 35-tooth MW spline. Get the MW Hi-Torque axle with the spline that's best suited to your needs.

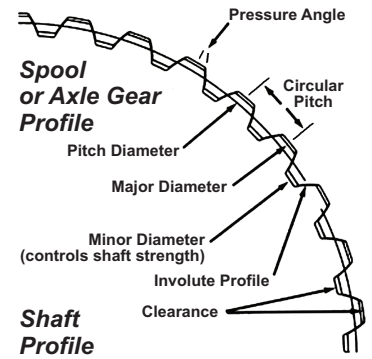

**PART NUMBER TRACE ABILITY** Every Mark Williams produced part carries a visible part number. Our part numbering system uses a revision letter at the end of the part number that indicates the design change. Example: A spool with part number 53133-H indicates there have been 8 changes to this part (A thru H) since it was first introduced. Anytime a part is re-designed to the point it is would no longer be interchangeable with earlier versions, it is assigned a new part number. Parts that are produced from castings may have two revision letters. Our 9" thirdmember housing 57448 is on the U casting revision and the V machining revision, (at the time of this publication printing). This system allows trace-ability of our parts and can assist identifying the age of parts in the field. All axles and driveshafts are serialized allowing us to access the build information. Other parts have recorded production batch numbers that allow trace-ability. All raw materials used to produce MW products are certified from the mills and are traceable to the individual products.

# How To ORDER AXLES

Every set of Mark Williams axles are custom built to meet each customer's requirements. This requires accurate information to insure that the axles are a perfect fit. You will need to provide as many of the dimensions shown as possible for your application.

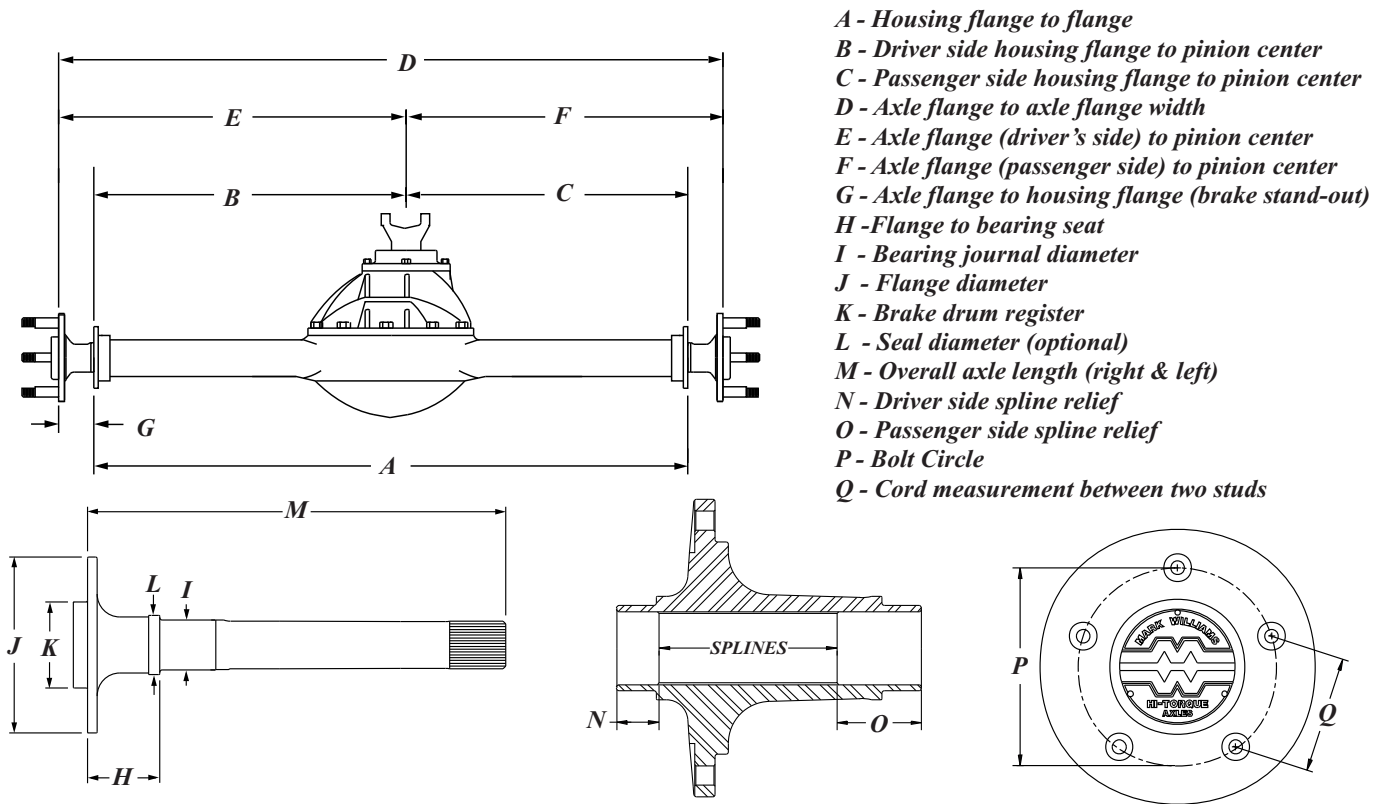

- A - Housing flange to flange
- B - Driver side housing flange to pinion center
- C - Passenger side housing flange to pinion center
- D - Axle flange to axle flange width
- E - Axle flange (driver's side) to pinion center
- F - Axle flange (passenger side) to pinion center
- G - Axle flange to housing flange (brake stand-out)
- H - Flange to bearing seat
- I - Bearing journal diameter
- J - Flange diameter
- K - Brake drum register
- L - Seal diameter (optional)
- M - Overall axle length (right & left)
- N - Driver side spline relief
- O - Passenger side spline relief
- P - Bolt Circle
- Q - Cord measurement between two studs

**STARTING FROM SCRATCH** The following steps have proven to be the most accurate method for determining the width of the rear end assembly when building a new car.

- 1) Obtain a set of the widest tires and wheels (with appropriate offset) to be used.
- 2) Remove the stock rear end housing and make modifications to inner fender wells as required.
- 3) Position the tires/wheels under the car, and through the use of jack stands, etc. place the car in the desired running attitude.
- 4) With wheels in position, measure from wheel mounting surface to the opposite wheel mounting surface. This will give you the proper axle flange to axle flange dimension (D). Allow for brake hats or drums.
- 5) Also supply the (E & F) distance or indicate if the pinion is centered or the amount of pinion offset required and the direction. Offset toward the passenger side is normal and toward the driver side is abnormal.

**MEASURING AN EXISTING HOUSING** Measure the distance to the outside of both housing flanges (A). Not all pinions are centered, so it is also essential to measure the distance from the housing flange to the center of the pinion on both driver and passenger side (B & C).

**MEASURING EXISTING AXLES** Provide as many measurements as possible. Use of a MW 35 or 40 spline spool will change axle lengths in relation to axles with stock splines. A Mark Williams salesman can help with questions about changes in axle lengths.

**SPOOLS** All spools are not manufactured the same. If the spool to be used is a MW spool, the part number on the spool will give us the required information. If the spool is from another manufacturer, please check the spline count and location of the spline as measured in the illustration above (N & O values).

**BOLT CIRCLE** If you do not know the bolt circle (P value) of a 5-bolt application, measure the center-to-center distance (Q) between two adjacent wheel studs and reference the table below.

- 4-1/2" B.C. = 2.645" normal later Ford pattern
- 4-3/4" B.C. = 2.792" normal Chevrolet pattern
- 5" B.C. = 2.939" normal older Olds-Pontiac
- 5-1/2" B.C. = 3.233" normal early Ford and T/F wheel pattern



# HI-TORQUE AXLES

**MW STANDARD "HI-TORQUE" AXLES:** MW standard forged steel axles have set the quality standard in the industry for racing axles. The standard axles will normally be used in applications where weight is not a large factor for your car. The standard axle is the heavy duty version in the MW "Hi-Torque" axle line. Each MW axle order is custom manufactured per application with all axles designed to accept an axle bearing with the largest diameter possible for the particular housing end being used, then each axle shaft is tapered from bearing journal to spline. This combination of the large bearing diameter and tapered shaft increases torsion and bending capacity. All Mark Williams "Hi-Torque" axles are available in any spline and bearing combination with the bolt pattern or patterns of your choice and either 1/2" or 5/8" tapped stud holes. Dual patterns available without an extra charge. Flange lightening option available on standard axles for an additional charge. (weight 32 lbs\*)

50100

**SUPERLIGHT 35 SPLINE "HI-TORQUE" AXLES:** Rears that are limited to 35 spline spools can take advantage of MW 35 spline gun drilled axles. These axles are pocket lightened and "gun drilled" where the center of the axle shaft is bored (11/16" dia.) the entire length to resemble a gun barrel. This process is performed in house and allows us to control the bore finish assuring a quality product. This results in a superior product, fully capable of handling the shock loads of the heavier Super Stock cars that are limited to 35 splines! These operations result in a weight savings of roughly 19% over a pair of standard 35 spline MW "Hi-Torque" axles. (weight saving is 6.88 lbs on a pair of 35 spline 24" long axles)

50550

**SUPERLIGHT 40 SPLINE "HI-TORQUE" AXLES:** The next step in the high strength light weight axles would be the Mark Williams SUPER-LIGHT 40 spline "Hi-Torque" axles. In an effort to reduce rotating and un-sprung weight, these axles have been gun drilled to a 7/8" bore along with extensive milling of the axle flanges. This in conjunction with the additional machining behind the MW name plate and revised axle profile, result in a weight savings of approximately 35% over the standard MW axles. 40 spline axles are recommended for all race cars that can utilize a 40 spline spool. (19.9 lbs\*)

50500

**ULTIMATE "HI-TORQUE" AXLES:** It doesn't get any better than this. The MW ULTIMATE "Hi-Torque" axles represent the latest in axle and material technology. The axle profile and flange lightening are carried over from the SUPERLIGHT axles. The use of aircraft 300M alloy forgings make it possible to enlarge the diameter of the gun drill bore to 1" diameter without sacrificing strength. This represents a savings of 2.6 pounds per pair! You won't find lighter axles. Anywhere!!! (weight 17.3 lbs\*)

50800



\*Axle weights are per pair for 40 spline axles less bearings and studs to fit a 31" wide housing.

## DRAG RACE AXLE BEARINGS



56003 57803 58503 58504 58505 58507 58508 58509 58519 CB-58509

MW drag race axle bearings are special size ball and roller bearings. Many feature an "O" ring seal around the outside of the bearing. These are designed to utilize our wide selection of mating housing ends that will allow largest inside diameter, increasing the axle strength. Our technical representative can recommend the best bearing/housing end combination based on your brake requirements.

56003 Mopar Non-Adjustable Axle Bearings (pr)  
2.875" O.D., 1.562" I.D. for stock ends w/spiral lock.

57803 Small Ford Axle Bearings(pr)  
2.835"stock O.D. with larger than stock 1.562" I.D. stock Mustang end.

58503 Axle Bearings, 1-17/32" (pr)  
Sealed bearings 3.150" O.D., 1.532" I.D. stock Ford/Olds size.

58504 Axle Bearings, 1-5/8" (pr)  
Sealed bearings 3.150" O.D., 1.625" I.D. used for C-Clip eliminator.

58505 Axle Bearings, 45 mm (pr)  
Sealed bearings 3.150" O.D., 1.774" I.D. used for 40 spline axles

CB-58505 Axle Bearings, 45 mm (pr)

Ceramic bearings, Sealed bearings 3.150" O.D., 1.774" I.D.

58507 Axle Bearings, 1-9/16"(pr)  
Sealed bearings 3.150" O.D., 1.564" I.D.

58508 Axle Bearings, 3.347 X 45 mm, wide (pr)  
Double row sealed ball bearings 3.347" O.D., 45 mm I.D. For 58595/58598 Heavy Duty Symmetrical ends (o-ring is in housing end).

58509 Axle Bearings, 3.347 45mm I.D. narrow (pr)  
Narrow bearing for 58599 Symmetrical Pro-Stock ends.

58519 Axle Bearings.3.347 x 45mm, wide (pr)  
Wide single row bearings for deep 58595/58598 Heavy-Duty ends.

CB-58509 Axle Bearings,3.347 x 45mm (pr)  
Ceramic bearings, narrow, for 58599 Symmetrical Pro-Stock ends

# PRO STREET COMPONENTS

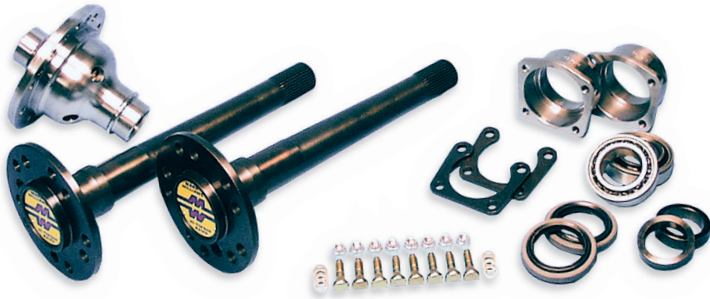

For those performance enthusiasts building sophisticated "Pro Street" type vehicles with narrowed rear ends, MW offers premium quality driveline components engineered specifically for daily street use, not "after market OEM" type axles. These are designed for those who want the BEST custom-made axles money can buy. MW "Pro Street" axles overcome the problem commonly encountered when using OEM or drag-type units: flange breakage. In fact, Mark Williams warrants each axle flange against breakage for two years when used in conjunction with a MW Pro Street housing end kit with Timken® 45mm bearings. Increasing axle shaft diameter and flange strength

are critical factors when deciding on axles for high powered street machines (which often weigh more and operate on more harsh surface conditions than their race-only cousins). Add serious muscle to any heavy street machine and you can bet the OEM driveline can't provide the necessary reliability. Why settle for anything less than premium quality MW components?

## PRO STREET AXLES

MW Hi-Torque Pro Street axles are custom built per order and are manufactured from the same Tri-Alloy forgings as our drag race axles, featuring 45mm bearings and thicker flanges for street use.

50400 Pro Street Axles, (pr)

*For use with any MW weld-on or bolt-on end kits on this page that incorporate the heavy-duty Timken® unit bearings*

## PRO STREET AXLE BEARINGS

MW's Pro Street axle bearing features a large 45mm (1.774") I.D. and is unique in that it can take thrust in either direction. This tapered roller bearing exceeds the radial capacity of common O.E.M. ball and roller bearings. Axle bearing assembly includes bearings, seals and M/W produced press on bearing lock rings. Requires matching MW housing ends.



58506S Unit Axle Bearing Assembly (pr)

*For MW Pro Street Axles, Timken® unit bearings with seals and press on lock rings.*

58506S

## WELD-ON HOUSING END KITS

The preferable method to obtain a reliable axle and bearing combination for Pro Street applications is the installation of our weld-on housing ends. MW has designed ends that accept the 45 mm bore Timken® bearing and a heavy-duty seal. A slightly bent housing can be corrected when installing new Pro Street weld-on ends. A variety of kits are available that accommodate the most popular brakes. If you are going to use disc brakes we recommend using the 58780 Symmetrical end kit that accepts the best designed brake kits and can incorporate a parking brake



68700 Weld-On Housing Kit for GM  
10 & 12 Bolt Ends

58780 Housing End Kit, Disc Brakes

*For use with MW Disc Brake Kits with symmetrical bolt pattern. Includes Timken® wheel bearings, seals and backing plate bolts.*

66700 Housing End Kit, Mopar Brakes

*For Mopar brakes. Includes Timken® bearings, retainers, seals and backing plate bolts.*

67700 Housing End Kit, Small Ford

*For small Ford brakes. Includes Timken® bearings, retainers, seals and backing plate bolts.*

67750 Housing End Kit, Large Ford

*For large Ford brakes (w/1/2" bolts). Includes Timken® bearings, retainers, seals and backing plate bolts.*

68700 Housing End Kit, Small GM

*For GM small brakes (Camaro, Chevelle, Nova). Includes Timken® bearings, retainers, seals and backing plate bolts.*

68740 Housing End Kit, Large GM

*For Large GM brakes (Impala, Biscayne & 1/2-ton truck). Includes Timken® bearings, retainers, seals and backing plate bolts.*

67870 Housing End Kit, New Style Ford

*For New Style Ford. Includes Timken® bearings, retainers, seals and backing plate bolts..*



# PRO STREET BRAKES

72300 Pro-Street Disc Brake Kit w/Park Brake . .1514.00  
*For Pro-Street Symmetrical type housing ends (MW #58580 or 58780 kit). This is the only kit with mechanical parking brake calipers.*

## Models without Parking Brake

72000 Olds Disc Brake Kit (ends rotated)  
*For MW 58550 housing ends rotated 90 degrees from stock.*

72100 Olds Disc Brake Kit (ends stock)  
*For MW 58550 housing ends in stock position.*

72200 Symmetrical Disc Brake Kit  
*For MW 58585 Symmetrical ends.*

72400 New Ford Disc Brake Kit  
*For MW 57860 housing ends.*

72500 Large Ford Disc Brake Kit  
*For MW 57820 housing ends.*

72600 Mopar Disc Brake Kit  
*For MW 53188 housing ends. Requires bracket modification.*

72700 GM Disc Brake Kit  
*For stock GM or MW 58560 passenger car housing end.*

72800 Small Ford Disc Brake Kit  
*For MW 57810 housing ends. Requires bracket modification.*

72900 GM w/C Clip Kit Disc Brake Kit  
*For stock GM passenger car housing end with MW C-Clip Eliminator kit. Requires modification to bearing housing.*

Mark Williams Enterprises has the ideal brake kit for the Pro Street and street rod enthusiasts that requires a parking brake. For use with MW's symmetrical housing ends. This brake kit has a provision for a floating mechanical wedge action parking brake caliper built into the caliper mounting bracket. As is the case with all other MW brake kits, the caliper mount also acts as the bearing retainer. The kit includes: MW's race proven 4 piston aluminum calipers with pads, vented cast iron rotors, aluminum brake hats, floating parking brake calipers with pads, caliper mounting brackets, and all of the necessary mounting hardware. This is a safe and reliable kit for Pro Street and street rod applications requiring a parking brake. (Note: bracket to anchor the parking brake cable must be fabricated.)

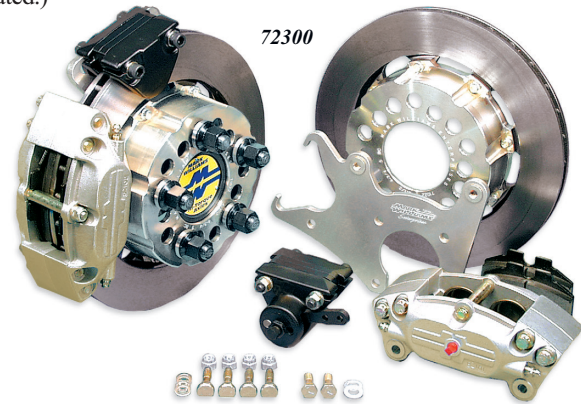

# BOLT ON RETAINER KITS

MW bolt-on retainer kits allow you to easily use MW "Pro-Street" axles in G.M. and Ford rear end housings without replacing housing ends. All bolt-on kits utilize a heavy duty Timken® unit bearing that can take thrust from either direction and exceeds radial and axial load capacity of common ball and roller bearings. Bolt-on ends are recommended if housing can not be narrowed. Weld-on kits should be used rather than this kit, when narrowing a housing.



67760 Bolt-On Adapter Kit, Large Ford  
*Allows the use of 50400 MW Pro Street Axles without changing the stock housing end. Must have large Ford ends with 3.150" O.D. bearings, 1/2" backing plate bolts. Includes bearings & seals.*

67770 Bolt-On Adapter Kit, New Style Ford  
*Allows the use of 50400 MW Pro Street Axles without changing the stock housing end. Must have New style large Ford ends with 3.150" O.D. bearings, 3/8" backing plate bolts. 3 9/16" x 2" pattern. Includes bearings & seals.*



68800 Wheel Bearing Adapter Kit, Small GM  
*Allows the use of 50400 MW Pro Street Axles without changing the stock housing end. Must have GM small car brake (Camaro, Chevelle, Nova). Includes bearings & seals should be used when narrowing housing.*

# PRO STREET LOCKERS

MW offers a Locker type differential that accepts larger than stock spline 1.5" diameter 35-spline axles for the 9" Ford rears. Axles must be manufactured specifically for this Locker. The spline and length are different from the M/W spool spline.

We also offer a 40 spline locker for the Dana 60™ rears. The spline and location is the same as the M/W 40spline spool axles.

187S-35C 35 spline, Locker, 9" 3.25 Ford Case  
*Requires 3.250 or 3.812 bore case.*

225S-40A 40 spline, Locker, Dana 60™ 3.73-4.10 Ratio

225S-40B 40 spline, Locker, Dana 60™ 4.56-7.17 Ratio



225S-40A

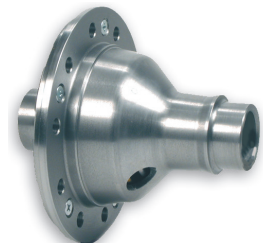

187S-35C

# WHEEL STUD KITS

MW drive studs are recommended in all drag racing applications using after-market wheels. The Drive Stud is designed so the 11/16" dia. shoulder on the stud is used to center the wheel, rather than the lug nut used with smaller studs. This system dramatically increases shear strength and eliminates bent wheel studs. MW drive studs require a 5/8"-18 thread holes in the axle flange. Studs are then secured in the flange with a jam nut. Wheels are held in place with an open end flanged lug nut and an aluminum washer that prevents marring the wheel. A standard MW drive stud kit comes complete with 10 steel drive studs, 10 self locking jam nuts, 10 aluminum washers, (specify thickness) and 10 steel Snap-Lock™ flanged lug nuts. Titanium drive studs are also available and listed below. The following page has lug nut options available at an additional cost. For applications using OEM steel wheels MW also offers high strength 1/2-20 screw-in type wheel studs.



## STEEL DRIVE STUD KITS

51500 Drive Studs 11/16" dia. (complete set)  
A=3-1/2" B=1-3/16" C=1-1/2" D=13/16"

51540 Drive Studs 11/16" dia. (complete set)  
A=2-11/16" B=1" C=7/8" D=13/16"

51560 Drive Studs 11/16" dia. (complete set)  
A=4" B=1-3/16" C=2" D=13/16"

51580 Drive Studs 11/16" dia. (complete set)  
A=2-7/8" B=7/8" C=1-3/16" D=13/16"

51590 Drive Studs 11/16" dia. (complete set)  
A=3-7/16" B=7/8" C=1-3/4" D=13/16"

Drive Stud Kit w/ MW Aluminum Lug Nuts  
Add "A" to Part Number (specify c-bore depth 1/8 or 3/8").

## TITANIUM DRIVE STUD KITS



Reduce rotating weight with the addition of a titanium stud kit. All studs are carefully manufactured to insure concentricity with the stud threads. All kits include titanium studs, self locking jam nuts, and choice of MW hard anodized aluminum lug nuts (51520 or 51521).

41540 Titanium Drive Studs 11/16" dia  
A=2-11/16" B=1.00" C=7/8". Save 1.2 lb (Specify nut)

41560 Titanium Drive Studs 11/16" Dia  
A=4" B=1 3/16" C=2" Save 1.2 lb (Specify nut)

41580 Titanium Drive Studs 11/16" Dia  
A=2-7/8" B=7/8" C=1-3/16" Save 1.2 lb (Specify nut)

## SCREW-IN WHEEL STUDS

MW offers 1/2-20 screw-in wheel studs in two standard lengths. The latest MW 2" and 3" studs feature a special thin 12 point head to help with brake component clearance. The stud features a small quick start on the threaded end. The G.N. wheel studs are made of 8740 aircraft quality material with 5/8-18 threads and they also have a quick start end. All stud kits include aircraft washers to help prevent the threads from wedging on the imperfect threads by the head.

51200 1/2-20 x 3-1/2" Wheel Studs, 12 point head (10)

51250 1/2-20 x 2" Wheel Studs, Allen head (10)

51255 1/2-20 x 2" Wheel Studs, 12 point head (10)

51260 5/8-18 Grand National Axle Studs, (10)  
Threaded to head (2-5/8" overall length.) 2" of thread

51270 5/8-11 Grand National Axle Studs, (10)  
Coarse thread threaded to head (3-3/8" overall length.) 3" of thread. Note: MW axles are normally produced with fine thread. Axles must be special ordered with 5/8-11 threads.

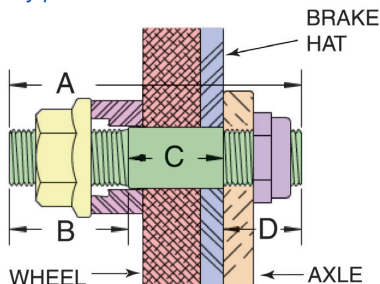

### SELECTING THE PROPER DRIVE STUDS

The most important factor when selecting the proper drive stud is that the drive shoulder of the stud be fully engaged in the wheel. It is recommended that the "C" length on the stud be slightly greater than the combined thickness of the brake hat or drum and the wheel. These two dimensions should be specified when ordering a MW drive stud kit. Washer thickness must be greater than the portion of the shoulder of the stud that extends past the face of the wheel.



# WHEEL STUD NUTS & STUD INSTALLER

With our Mark Williams stud nuts, an aluminum spacer washer attaches with a SnapLock™ over the base nut. The washer spins freely, but will not separate from the nut, this prevents marring of the wheels and losing washers. The aluminum washers are available in different thicknesses (3/16" to 3/4") to compensate for different wheel and brake hat combinations. This makes the nut a dimensionally and visually superior part. The thread pitch diameter is held extremely square with the flange which results in even pressure loading against the wheel and stud threads. MW also builds special integral billet aluminum lug nuts that are hard anodized for durability (see below). These nuts are sold with special thin aluminum washers and are standard nuts in MW titanium drive stud kits.

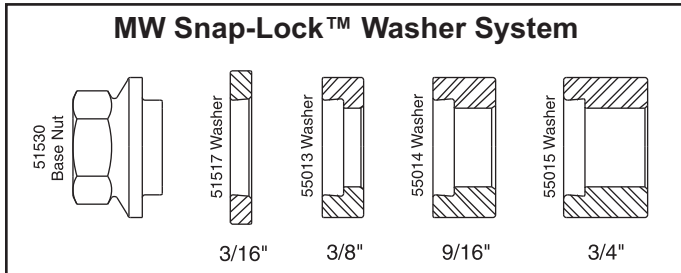

51530 Steel MW Snap-Lock™ Base Nut

*Replaces old 55016 standard flange steel nut*

55017 Aluminum Washer, Snap-Lock™ 3/16"

*For use with MW base nut, stainless or standard nut, 3/16" thick.*

55013 Aluminum Washer Snap-Lock™ 3/8"

*For use with MW Stainless Steel or 51530 nut, 3/8" thick.*

55014 Aluminum Washer, Snap-Lock™ 9/16"

*For use with MW base nut, stainless or standard nut, 9/16" thick.*

55015 Aluminum Washer, Snap-Lock™ 3/4"

*For use with MW base nut, aluminum or standard nut, 3/4" thick.*

## INTEGRAL ALUMINUM NUTS

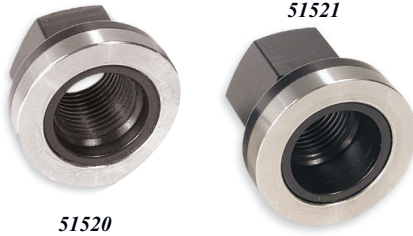

The MW integral aluminum lug nuts are for applications where every ounce of weight is critical. The part is produced from 7075-T6 aluminum alloy with a durable anodized hard coat finish. The integral aluminum washer snaps on to the nut and spins freely but will not separate from the nut, preventing accidental loss. The nuts have fixed counter bore depths of 1/8" and 3/8" that make them equivalent to using a standard nut and washer combination of equal thickness. These nuts come standard with all MW titanium drive stud kits for the lightest possible combination. Can also be used with steel drive studs.

51520 Encapsulated MW Nut, 1/8" grip (ea)

*1/8" grip, threads relieved 1/8" on wheel side of nut*

51521 Encapsulated MW Nut, 3/8" grip (ea)

*3/8" grip, threads relieved 3/8" on wheel side of nut*

## STUD INSTALLATION TOOL

The MW stud installation tool utilizes a threaded collet that clamps evenly on the threads of the stud to properly install and tighten drive studs in the axle flanges. This type of system eliminates possible damage to either the threads or stud shoulder that can happen without the proper installations tools.

600-H Housing for stud install collet

600-1 5/8-18 stud install collet

600-2 1/2-20 stud install collet

600-3 7/16-20 stud install collet

600-4 3/8-24 stud install collet

600-5 5/16-24 stud install collet

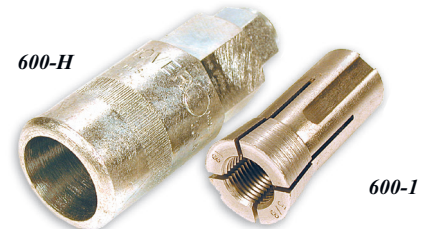

## SAFETY WIRE AND PLIERS

Use with any drilled bolt head to provide vibration proof positive bolt retention. MW 9" & 12 Bolt ring gear bolts are drilled for safety wire locks.



300-1 Safety Wire, 1 lb, .032 stainless

300-2 Safety Wire Twist Pliers 9"

## OFF ROAD DRIVE PLATE AXLES



These axles are designed for off road and circle track racing applications with Wide 5 (3/4 to 1 ton truck type hubs), Dana 60/70 (and most Dana 80) hubs, and 14-Bolt style full floating hubs. The 40-spline drive flanges are manufactured using aircraft quality alloy steel and are heat-treated and black oxide coated. The axles are available in standard 4340 steel or high strength 300M steel. The center section spline is available for any spool / carrier requirements. These parts are designed to work with factory axle hub bolts or studs. Covers are anodized aluminum with low-profile sealing o-rings. All sets feature MW true involute splines, and are heat-treated, polished, and shot peened to prevent stress crack propagation. The complete kit is comprised of shafts, flanges, caps, fasteners, o-rings, and retaining rings. Custom produced for each specific application with quick delivery.

50250 Truck Floater Axles 14 Bolt Drive Flange  
*Austempered 4340 40 (Spline drive flange) (1/2" bolt)*

50270 Truck Floater Axles Dana 60/ 70 Flange  
*Austempered 4340 Dana 60/70 type flange (7/16" bolt)*

50260 Truck Floater Axles 14 Bolt Drive Flange  
*300M material 40 (Spline drive flange) (1/2" bolts)*

50280 Truck Floater Axles Dana 60/ 70 Flange  
*300M material 40 (Spline drive flange) (7/16" bolts)*

## F350 UNIT HUB AXLE DRIVE ASSEMBLIES

Weld Cup for  
 3-1/2" or 4" tube

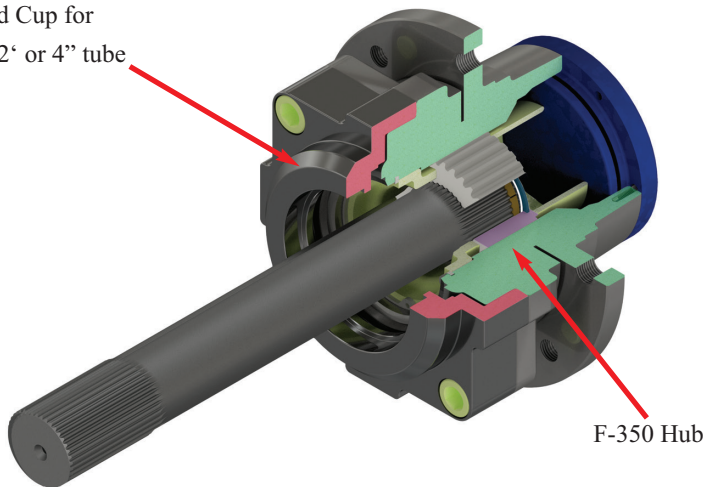

F-350 Hub

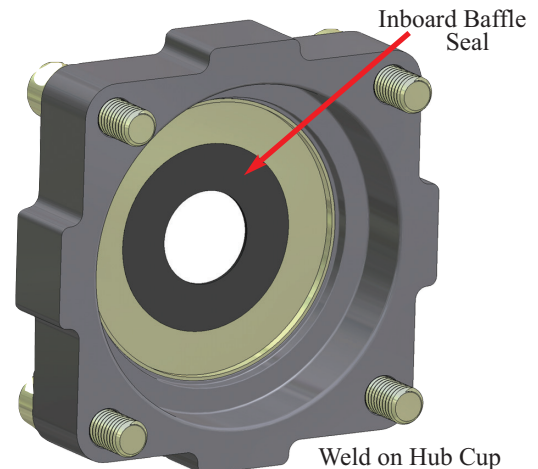

Weld on Hub Cup

The F350 Unit hub is an economical and bulletproof way to upgrade from a conventional truck floater. MW offers axles with the Donut Spline Adapter and cover that are made to fit the OEM hub. Our splines are manufactured with a slight crown that allows some misalignment without bowing the axle shaft. This bowing creates forces on the center section that will eventually destroy gears and bearings. Weld Cups for the Hub are available for 3-1/2" and 4" tube housings. Similar to a traditional housing end, cut the OEM housing ends off and weld the hub cup on to the axle tube. Then bolt the Unit Hub on and install axles.

50255 Axles for F350 Hub, Donut & Cover  
*Austempered 4340 (Any center spline to match spool)*

50265 Axles for F350 Hub, Donut & Cover  
*300M Aircraft Alloy (Any center spline to match spool)*

50290 Weld Cup for F350 Hub 3-1/2" (ea)  
*Alloy steel for 3-1/2" tube (with baffle seal)*

50295 Weld Cup for F350 Hub 4.0" (ea)  
*Alloy steel for 4" tube (with baffle seal)*

**MARK WILLIAMS Enterprises®**

# VIPER CV JOINT CONVERSIONS

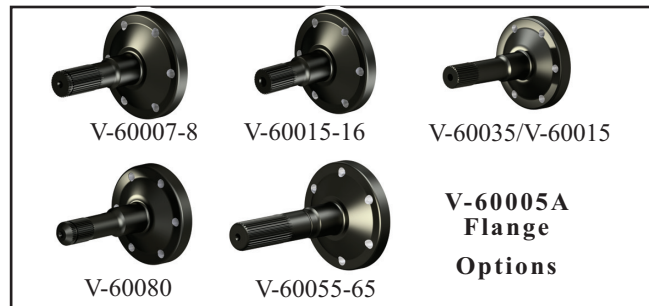
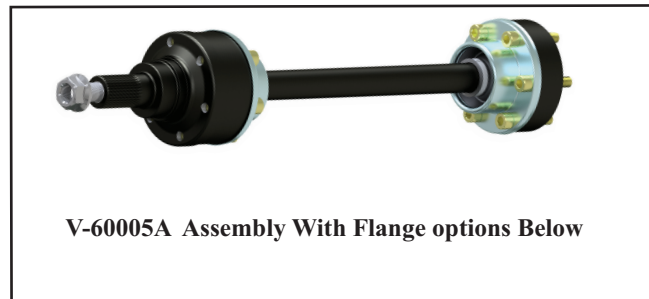
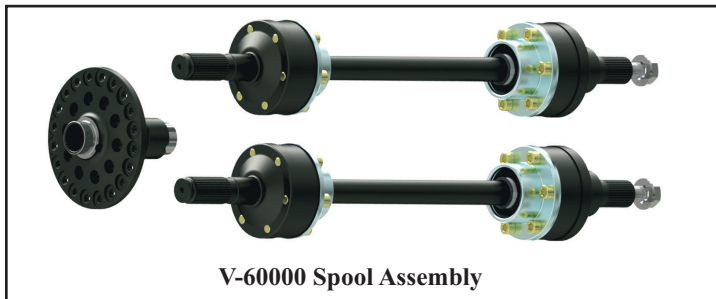

Viper enthusiasts can now have improved strength and reliability compared to OEM axle drivelines. Generation 1 cars handling is drastically improved by the **V-60025A** CV configuration. We have created a CV driveline to replace the U-Joint system for the early Vipers. Our bolt in replacement assembly features series 15 CV joints with chrome-nickel-alloy mating wheel hubs, and differential flanges. All the kits axle shafts are 300M material heat-treated and shot peened.

For the higher power applications we have increased the **V-60005A** kit featuring series 21 CV joint, a 33 spline 300M drive shaft and a 32-spline wheel hub. Several differential CV flanges are available to match the ring gear carriers for Posi-Traction, Quaife and OS Giken differentials.

The **V-60000** kit utilizes a series 21 CV joints with 32-spline wheel hubs, a lightened 35 spline steel spool and 300M axles, ideal for drag strip or application requiring a locked differential.

**V-60000 Viper Spool and CV Shaft Kit**  
*Includes Lightweight 35 spline spool, spool CV Flanges, Inner CV Flanges, Half Shafts, CV Joints Outer Flanges and the required broaching of the rear hubs.*

**V-60010 Rework Rear Hubs (pr)**  
*Bore and broach rear hubs to accept larger spline half-shafts.*

**V-60005A Viper CV Half-Shaft Assembly**  
*Direct Viper Generation 2 or 3 Replacement. Modifications to outer hub required, .*

**V-60025A Viper CV Half-Shaft Assembly**  
*Viper Generation 3 replacement. Factory upgrade. No modifications required.*

## VIPER CURRENT 300M SHAFTS & CAP

The late model Vipers have room for improvement in the axle shaft department. We have produced replacement axles for the double spline configuration, and the axle with the direct bolt on CV flange. Both are produced from 300M material and shot peened for extra durability. These are a direct replacement for the factory parts.

**V-60100/V-60105 Viper CV Flange Axle Shafts (pr)**  
*Fits late Viper with one piece CV axle shafts CV joint bolt directly to the flange. 300M Heat Treated and shot peened. Includes seal protector.*

**V-60090/V-60095 Viper Double Spline Diff Shaft (pr)** *Direct replacements for 30 t x 31t OE shafts. 300m material uses the OE flange for the CV joint. Ultra Strong 300M, heat treated and shot peened.*

**V-60030 Pinion Preload Spacer**  
*Sold hardened must be machined to length*

**V-60050 Main Cap, Differential (one)**  
*Requires fitting to case with milling operation*



# HONDA DRIVELINE & BRAKES

M-W engineering has developed a “bulletproof” hub-to-hub driveline that incorporates absolutely no factory parts! The interior shafts are substantially beefier than OEM, with the spline 45% larger than the factory intermediate shaft! CV joints are also significantly larger than stock and of a high angle design. A large 15-plunge style CV joint replaces the factory “tripod” style inner joint, and a forged steel spool ensures equal power transfer with absolute reliability. Outer shafts are made from 300M heat treated and shot peened. The finishing touch comes in the way of racing brakes with 11-3/4” drilled steel rotors, aluminum hats and 4-piston aluminum calipers. Complete packages are available for all popular Honda/Acura applications.

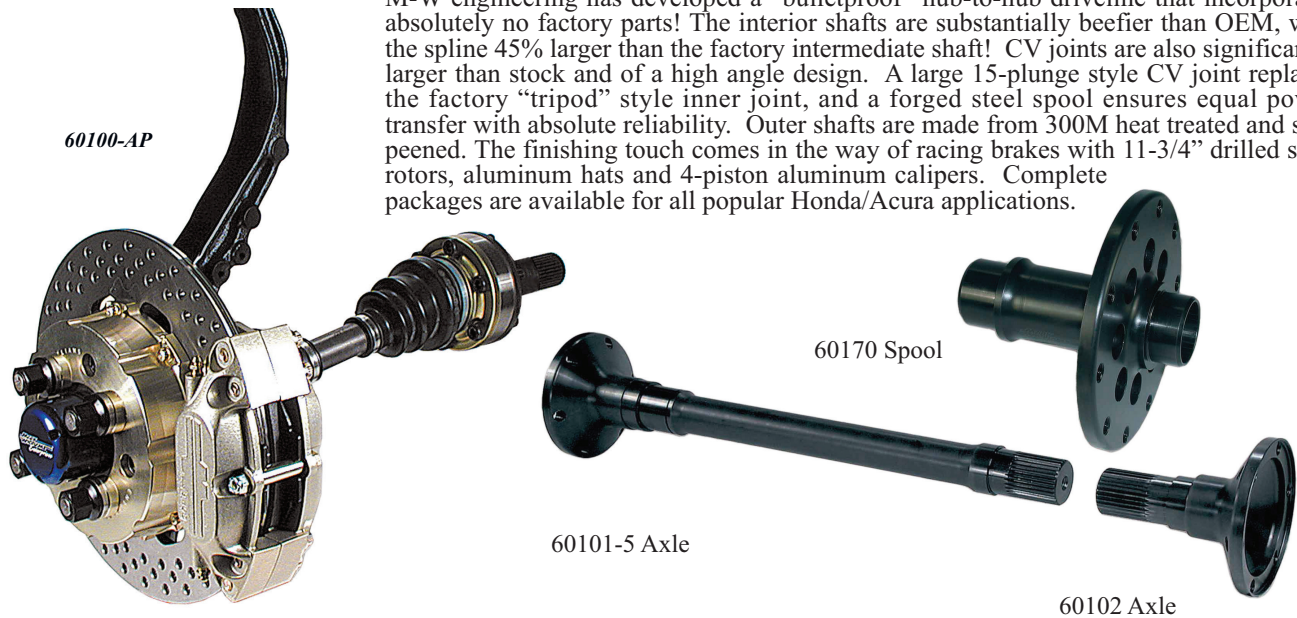

## FORGED 4140 SPOOL

- Lightened flange to reduce rotating mass

## HALF SHAFT ASSEMBLY

- Increased shaft size results in a 75% increase in overall strength

## DISC BRAKES

- Custom mounting brackets insure seamless installation

60100-AP Accord/Prelude Driveline and Brake System

*Complete system for Accord/Prelude trans including spool, intermediate shafts, half shafts with CV joints, outer wheel flanges, drive stud kit and MW brake kit with MW calipers and drilled steel rotors*

60100-LS Honda/Acura LS Driveline and Brake System

*Complete system for Honda LS trans including spool, intermediate shafts, half shafts with CV joints, outer wheel flanges, drive stud kit and MW brake kit with MW calipers and drilled steel rotors*

60100-GSR Honda/Acura GSR Driveline and Brake System

*Complete system for Honda GSR trans including spool, intermediate shafts, half shafts with CV joints, outer wheel flanges, drive stud kit and MW brake kit with MW calipers and drilled steel rotors*

# PANTERA AXLES AND CV CONVERSION

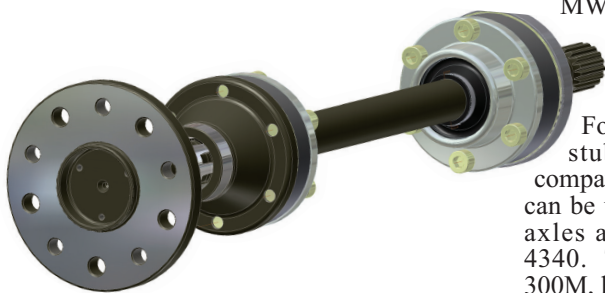

MW now has CV Joint conversion kit for Ford Pantera. This series 15 CV kit replaces the original U-Joint style half-shafts. Enjoy all the benefits of a CV joint style design, including, better handling, smoother operation, less binding, and an increased range of motion.

For a truly superior axle assembly, we have optional gun-drilled 50510G stub axles. The CV to axle Flanges are compatible with the original half shafts and can be used for the CV upgrade. All stub axles and CV flanges are made from 4340. The CV-shaft is produced from 300M, hardened and shot peened.

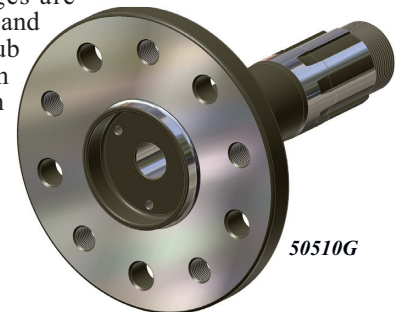

50510G

P-6000 Half-Shaft CV Conversion Kit

*Includes everything you need to convert to CV Joints.*

50510 Pantera Stub Axles (Pair)

*4340 8 spline stub axle pair. OEM Replacement axle.*

50510G Gun Drilled Pantera Stub Axles (Pair)

*Same as 50510 but includes 5/8" gun-drilled center.*



## C5 CORVETTE HALF SHAFTS

If you have a hot Corvette, this is the differential output shaft that you need to put reliable power to the ground. With generous shaft radiuses to eliminate stress risers, and manufactured from 300M aircraft steel, these shafts have been designed to handle the rigors of any high powered application. Applications are for 1997 and newer C5 Corvette axle shafts that attach to the constant velocity (CV) joints. The internal intermediate shaft is also available. Differential shafts can also be built in custom lengths for street rod or specialty applications using a transplanted Corvette rear. Axle shafts are sold in pairs. Intermediate shafts are sold as singles.



50220 C5 Corvette 300M Axle C/V Shafts (pair)  
300M C.V axle shafts (pair) '97 thru '02 C5 Corvette Replaces GM  
P/N 10311201

50210 C5 Corvette 300M Intermediate (one)  
300M intermediate shaft for '97 thru '02 C5 Corvette. Replaces GM  
P/N 88893900

## CORVETTE OVERSIZED HUB YOKES

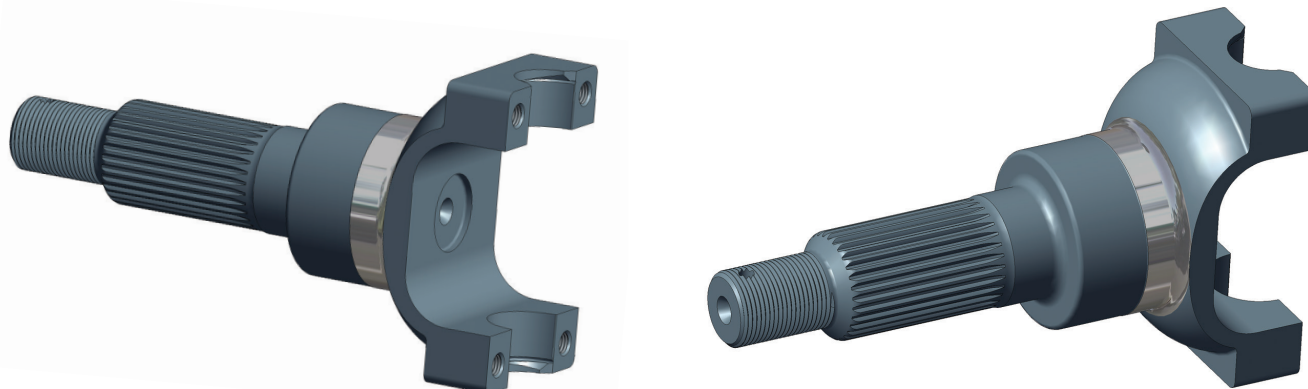

This is a fix for the early model Corvette rear hub shaft/yoke, that are prone failure. We have increased the spline size to a 31-tooth spline and the material is aircraft alloy steel through-hardened for maximum strength. The threads are fine thread metric and comes with the nut and fine adjustment locking device. It does require boring and re-broaching you present hubs to 31-tooth spline, which we can do in house.

50225 Corvette Bullet Rear Hub Shaft (each)  
Produced from billet aircraft quality materials thru hardened heat treated 31 tooth splines. Includes spindle nut with fine adjustment

50226 Re-Bore and Broach Customers Hubs (pair)  
Rework hubs for 31 tooth spline to fit 50225 Hub Shaft.

## MITSUBISHI 3/S OUTPUT SHAFT



Made from 300M, the 3SI-25 output shaft is designed to handle increased horsepower in your 3/SI application. Our shaft is designed to replace the original transfer case output shaft in AWD Stealth and 3000 GT cars with 2nd generation transmissions. The 3SI-225S is a 300M upgrade to the stock transfer case spool. Weak splines in the spool will no longer be an issue.

- 3SI-25 Transfer case 25 spline output shaft
- 3SI-18 Transfer case 18 spline output shaft
- 3SI-225S Transfer case spool 25 spline (2nd gen. trans.)

## STEEL SPOOLS

All Mark Williams steel spools are precision machined from 4140 steel forgings and through hardened. The final grinding operation also ensures a near-zero runout on the ring mounting surface. MW spools also have an increased cross-section under the ring gear register to prevent ring gear deflection.

Mark Williams steel spools are offered in both standard and lightweight versions. The major differences are the addition of lightening holes drilled through the hub of the spool and a profile milled ring gear flange. This reduces the weight by as much as 25% over the standard version without sacrificing the strength of the spool.

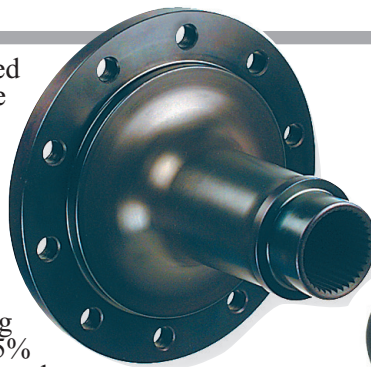

53140  
Standard Weight



53137  
Lightweight

## STANDARD STEEL SPOOLS

53120 35 Spline 8" Ford Spool  
*MW 35 spline. 10.5 lbs.*

53132 35 Spline 8.8" Ford Spool  
*MW 35 spline. 14 lbs. Must use 57900 ring gear bolts.*

53136 40 Spline 9" Ford Spool  
*For 3.250" bore case, requires 45 mm bore wheel bearing and matching housing ends. 11 lbs.*

53140 35 Spline 9" Ford Spool  
*MW 35 spline. For stock 2.893" or 3.062" case. 11 lbs.*

53144 31 Spline 9" Ford Spool  
*Stock type 31-spline. 12 lbs.*

53146 35 Spline 9" Ford Spool  
*MW 35 spline For 3.250" bore case. 12 lbs.*

53130 35 Spline 8.5 GM 10-Bolt Spool.\*  
*MW 35 spline. For 1970 or later. 14 lbs.*

53160 35 Spline 12 Bolt Chevrolet Spool \*  
*MW 35 spline. 14 lbs.*

53164 30 Spline 12-Bolt Chevrolet Spool \*  
*Stock type 30 spline. 14 lbs. (limited stock)*

53180 35 Spline 8-3/4" Mopar Spool  
*MW 35 spline. 14 lbs.*

53186 30 Spline 8-3/4" Mopar Spool  
*Stock type 30 spline. 14 lbs.*

53150 57-64 Olds-Pontiac 35 Spline  
*Stock type 35 M/W spline. 14.2 lbs.*

53175 Dana 60 35 Spline  
*M/W 35 spline, 4.56-7.17 ratio gear. 16.6lbs.*

14B-SPL-30 14 Bolt GM 30 stock spline  
*Stock type 30 spline. 24.7 lbs.*

14B-SPL-40 14 Bolt GM 40 spline  
*40 spline requires aftermarket spindles with increased bore 24.7 lbs.*

14B-SPL-35 14 Bolt GM 35 Dana spline  
*Dana 35 spline . 24.7 lbs.*

\* Requires C-Clip Eliminator kit or other axle retention method

## LIGHTWEIGHT STEEL SPOOLS

D1554F33 33 Spline 9" Ford Spool  
*Strange Engineering spool (not profiled)*

53125 40 Spline 9" Ford Lightweight Spool  
*For 3.812" case bore and 1/2" ring gear bolts. 9.7 lbs*

53127 40 Spline 9" Ford Lightweight Spool  
*For 3.812" bore case and 7/16" ring gear bolts. 9.7 lbs*

53129 40 Spline Modular 12 Bolt LW Spool  
*MW 40 spline. 12.5 lbs.*

53134 35 Spline 8.8 Ford Lightweight Spool  
*MW 35 spline. Must use 57900 ring gear bolts 11 lbs.*

53137 40 Spline 9" Ford Lightweight Spool  
*For 3.250" bore case. 8.5 lbs.*

53138 35 Spline 9" Ford Lightweight Spool  
*Summers Bros. type for 3.250" bore case. 9 lbs.*

53145 35 Spline 9" Ford Lightweight Spool  
*MW 35 spline for 2.983 or 3.062 bore case. 8.75 lbs.*

53147 35 Spline 9" Ford Lightweight Spool  
*Strange type for 3.250" bore case. 10.5 lbs.*

53148 35 Spline 9" Ford Lightweight Spool  
*MW 35 spline for 3.250" case. 9 lbs.*

53165 35 Spline 12-Bolt Chevy LW Spool \*  
*MW 35 spline. 11 lbs.*

53173 35 Spline Dana 60 Lightweight Spool  
*MW 35 spline. For Series 3 gears. 17 lbs.*

53175 35 Spline Dana 60 Lightweight Spool  
*MW 35 spline. 17 lbs.*

53177 40 Spline Dana 60 Lightweight Spool  
*Requires 58505 bearings and proper housing ends. 16 lbs.*

53187 35 Spline 8 3/4 Mopar LW Spool  
*MW 35 spline. 12.5 lbs.*

53265 35 Spline 12-Bolt Lightweight Spool\*  
*MW 35 spline 3.250" bore carrier 11.1 lbs.*

\* Requires C-Clip Eliminator kit or other axle retention method



## ALUMINUM SPOOLS

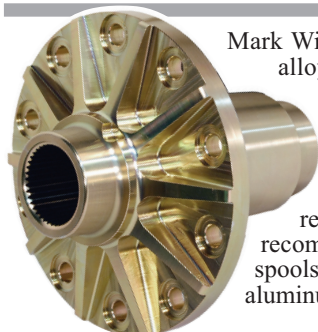

Mark Williams offers spools manufactured from High Strength forged aluminum alloy. M/W's aluminum spools are successfully being used in Pro Stock, Comp, Super Comp, Super Gas and Stock eliminator cars. They are machined from 7075-T6 aluminum alloy forgings and finished with the M/W Gold Coat. Aluminum spools are approximately half the weight of the profile milled steel spools. The 40-spline spools are available for 9" thru 10" Fords, 11" Modular as well as Dana 60 rears. The 31-spline aluminum 9" Ford spools are also available but recommended only for oval track racing. Aluminum 9" Ford 40 spline spools must be used in a case with a 3.812" or 4.00" bore. The 35 spline aluminum 9" Ford spool requires a case with a 3.250" bore.

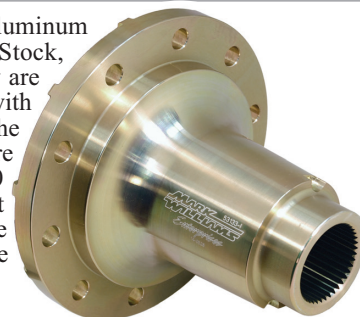

53123 9" Ford Aluminum Spool

*Stock Ford 31 spline, weight 4.9 lbs*

53133 9" Ford Aluminum Spool

*MW 40 spline, for 3.812 bore case. 4.7 lbs*

53135 9" Ford Aluminum Spool

*MW 35 spline, for 3.250" bore case. 4.9 lbs.*

53153 Olds/Pont '57-64 Aluminum Spool

*35 Spline M/W Spline 2.00 ID Bearing with hard bolt seat washers*

53158 12-Bolt Aluminum Spool

*\*MW 35 spline, housing must be bored to 3.250". Includes 58925 shim kit and 53161A bearing kit. 5.3 lbs.*

53166 12-Bolt Modular Aluminum Spool

*MW 35 spline for 12-bolt modular housing, weight 5.2 lbs.*

53174 Dana 60 Aluminum Spool

*MW 40 spline, 45mm bore axle bearings and proper housing ends required. 8 lbs.*

53179 8-3/4" Mopar Aluminum Spool

*MW 35-spline, weight 5.2 lbs.*

53104 11" Aluminum Spool 40 spline

*4 series 3.70 to 5.83 ratio weight 11.8 lbs.*

53108 11" Aluminum Spool 40 spline

*3 series 2.91 to 3.20 ratio weight 11.8 lbs.*

## LOCKING CARRIERS



**LOCKING DIFFERENTIALS** are offered for popular 9" Ford applications (28 and 31-spline), as well as Dana 60 rear ends. These units are designed to provide power to both wheels even in those situations where one tire loses traction. Detroit lockers will also compensate for differences in wheel speed when turning corners by letting the wheel with the larger turning radius overrun and unlock from the other wheel.

187S-13A 9" Ford 28 spline Locker

187S-17B 9" Ford 31 spline Locker

187S-35C 9" Ford 35 spline Locker

*Nodular iron housing. Requires 3.250" bore case.*

225S-23A Dana 60 Detroit Locker®

*35 Spline for 4.56-7.17 ratio gears.*

225S-40A Dana 60 Locker

*40 Spline for 3.73-4.10 ratio gears*

225S-40B Dana 60 Locker

*40 Spline for 4.88-7.17 ratio gears*

## BILLET OPEN CARRIERS

**Billet 9" Ford**



**Modular 11"**

MW manufactures steel billet open carriers made from 4140 chromoly. Carriers are available for the 9" Ford and the MW 11" Modular rear. The 9" unit has 31 spline axle gears and 4 pinion gears for added strength. The bearing journals are over size and require a 3.250" bore case. The 11" carrier is also a 4 pinion gear design and is available with 40 or 35 spline axle side gears. The 11" carrier is available for 2.91 and 3.20 ratios and 3.73 thru 5.83 ratios.

57260 9" Open Carrier, 31 spline

*Special 4140 billet housing with 4 spider gears for 3.25" bore case.*

90030 Modular 11" Open Carrier, 40 spline

*Special 4140 billet housing and spider gears for 2.91-3.20 ratio gears.*

90034 Modular 11" Open Carrier, 40 spline

*Special 4140 billet housing and spider gears for 3.73-5.83 ratio gears.*

## Posi-TRACTION UNITS

There are a number of excellent after-market posi-traction units which have proven to be exceptionally reliable in increased power street machines. These units provide increased traction prior to wheel spin. This is accomplished through the use of pre-loaded friction discs and, to some degree, the wedging action of the axle gear. This distributes torque to the wheel with superior traction rather than letting the wheel without traction spin free. All Eaton™ units are equipped with carbon fiber clutches and are available for 10 and 12 Bolt GM passenger car and truck rears as well as 8.8" Ford rears.

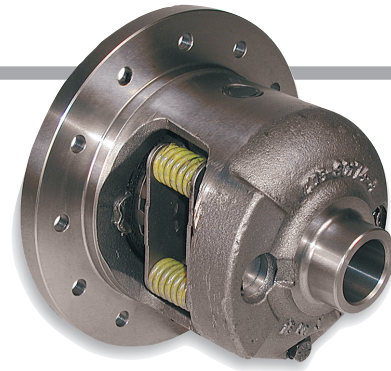

57311 9" Ford Posi-Traction

*31 spline clutch O.E. type posi-traction.*

19510 12 Bolt Eaton™ Posi-Traction

*30 spline with 800 lb clutch preload. For 3.90-6.14 ratios.*

19554 12 Bolt Eaton™ Posi-Traction (Series 3)

*30 spline with 400 lb clutch preload. For 3.08 to 4.10 ratios.*

19555 12 Bolt Eaton™ Posi-Traction

*30 spline with 400 lb clutch preload. For 4.10 to 6.14 ratios.*

19556 12 Bolt Eaton™ Truck Posi-Traction

*400lb preload unit, 30-spline for 3.73 to 5.38 ratio.*

19557 8.5 10 Bolt Eaton™ Posi-Traction

*28 spline with 400 lb clutch preload. For 2.73 to 5.57 ratios.*

19588 8.8 Ford Eaton™ Posi-Traction

*31 spline with 400 lb clutch preload. For 3.08 and up ratios.*

19603 8.2" GM Eaton™ Posi-Traction

*28 spline with 400 lb clutch preload. For 3.08 and up ratios.*

## BEARINGS AND RING GEAR BOLTS



All MW spool bearing kits feature Timken® bearings and races. MW also offers special bearing adapters to allow the use of spools for smaller bore sizes to be used in larger bores. MW ring gear bolts are manufactured with a ground shoulder to drive against, while the 12 point bolt heads are drilled to accept aircraft type safety wire. This fool-proof method eliminates the chance of the ring gear bolts loosening and "backing out".

### FORD SPOOL MATING PARTS

53121 8" Ford Spool Bearings

53124 9" Ford Spool Bearings 3.812 O.D.

53126 9" Ford Spool Bearings 3.812 O.D.

*To use a spool with 2" dia. journals in a 3.812 case*

53131 8" Ford and 8.5" 10-Bolt Spool Bearings

53141 9" Ford Spool Bearings, 2.893" O.D.

53142 9" Ford Spool Bearings, 3.062" O.D.

53143 9" Ford Spool Bearings, 3.250" O.D.

53210 9" Ford Spool Bearings 3.812 O.D.

*Angular contact for 2.25 id x 3.812 od*

53220 9" Ford Spool Bearings 4.00 O.D.

*Angular contact for 2.25 id x 4.000 od*

57510 Spool Shim Adapter, (pr)

*To use a spool with 1.7" dia. journals in a 3.250" case*

57570 Adjuster Adapter, (pr)

*To adapt a 3.062" bearing to 3.250" bore case. MW case ONLY*

57900 9" Ring Gear Bolt Set

*7/16"-20 threads, 12 point 3/4 hex, safety wire hole*

57920 9" Ford Ring Gear Bolt Set 1/2-20

57940 Thin 9" Ford Ring Gear Bolt Set 1/2-20 **GM**

### SPOOL MATING PARTS

53151 '57-64 Olds/Pontiac Spool Bearings

53157 GM 12 Bolt Inner Carrier Shim, (ea)

53161 GM 12 Bolt Spool Bearings

53161A GM 12 Bolt Spool Bearings (for 53158)

58900 MW G.M.12 Bolt Ring Gear Bolt Set

### DANA 60 AND 8-3/4 MOPAR MATING PARTS

53171 Dana 60 Spool Bearings

56900 Dana 60 Ring Gear Bolt kit

53181 8-3/4" Mopar Spool Bearings

53900 8-3/4" Mopar Ring Gear Bolts



# RING AND PINION GEARS

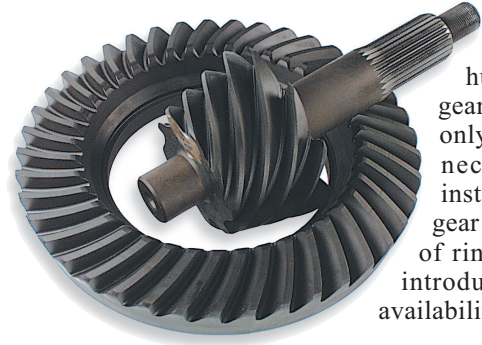

Mark Williams Enterprises, Inc. is one of the nation's largest warehouse distributors for several manufacturers. At any given time, you'll find hundreds of ring & pinion gear sets in stock at MW! This includes standard gears for oval track and street use as well as 9310 Alloy "Pro" gears for drag race only applications. Additionally, Mark Williams Enterprises, Inc. has everything necessary to properly install and set up a rear end gear set. This includes installation kits, tools, measuring devices, gear marking compound, special ring gear bolts, safety wire and gear lube. On the following pages you will find a listing of ring and pinion sets available at the publication time. Different vendors may introduce any additional ratios following this publication. Call 800-525-1963 for availability and pricing on items not listed.

• **SAME-DAY SHIPPING OF STOCK GEARS** • **COMPETITIVE PRICES** • **COURTEOUS & KNOWLEDGEABLE SALES STAFF**

## 8620 "STANDARD" GEARS

Standard Gears are primarily used in oval track and street applications. The material and heat treating provide excellent wear service life but doesn't handle shock loads as well as Pro gears. 9" Ford standard gears have a 28 spline pinion.

## 9310 "PRO" GEARS

"Pro" gears are designed specifically for drag racing. The 9310 alloy and heat treat are ideally suited to absorb high impact shock loads. 9" Ford ratios from 4.86 to 6:50 have 28 spline pinions. Select ratios available for 12 Bolt and Dana 60.

## "INCREASED SIZE PRO" GEARS

These 9", 9 1/2" and 10" Ford gears are built specifically for ultra high horsepower drag racing applications from 9310 material. All available ratios (2.91 to 4.86) most have a large 35 spline shaft.

# 9" FORD GEAR NOTES

## CASE CLEARANCE

While many new 9" gears are now manufactured for case clearance, many 9" Ford ring gears require modification to clear the pinion pilot bearing area. Do not grind on the case. Instead, chamfer the ring gear for clearance. A gauge tool is available (57486) that checks the profile and gauges the interfering material if necessary.

## LUBRICATION

We recommend using four quarts of MW-Torco GL-6 racing gear oil, SAE 85w140, Part number 55-0030, 1qt., This is a non-synthetic lube with additional extreme pressure additives to prevent galling. We do not recommend synthetic lubes for Drag Race applications. Oval Track applications require a baffle to prevent all the lube from becoming built up in the right axle housing tube. Our rear end filler bung and cap, part numbers 5015 & 5016 installed in the top of the housing make it easy to fill.

## PINION BEARING

If using a stock Ford front pinion bearing support, it must be the unit that has the HM89443 rear cone. Some standard pinion Pro Gears must use a HM89444 rear cone. This bearing has a larger radius that matches the increased radius in the pinion. Do not use the OEM pinion support with the M-88048 rear bearing. It will not stand the load and will fail destroying the gear set.

## RECOMMENDED PINION SUPPORTS

The recommended pinion support is our heavy duty Taper/Taper support part numbers 57620 for 28-spline input, or 57630 for 35-spline input. Both use larger Timken® bearings front and rear. The next step is the Ball/Taper support that has a lower preload and is capable of much higher RPM. Our tests have shown that this bearing combination has less pinion deflection than the double Timken® bearing units. This unit utilizes a Timken® front bearing with an angular contact bearing in the rear. The standard 28-spline pinion uses part number 57670 and the 35-spline pinion is 57680. These two are most popular units and are used on most thirdmember builds. An option for either of the units is a ceramic ball rear bearing that is lighter and reduces the rolling friction.

## DOUBLE ANGULAR BALL BEARING SUPPORT

The low friction 57022 32-spline input third members utilize a dual angular contact bearings in the pinion support, optionally with ceramic balls for further friction reduction. Additionally we now have a new series of pinion supports that have dual ball bearings with 28-splines (P/N 47670) and 35-splines (P/N 47680). Any of these supports can have the ceramic ball upgrade.

## WHAT SIZE GEAR 9", 9-1/2" OR 10"

Over the years we have strived to increase the durability for the 9" Ford type differential. In the early days the standard 9" diameter 8620 alloy ring and pinions were the only choice. Then the 9310 alloys were introduced with improved gear life. The next problem was twisting the pinion spline in two the with the Top Fuel cars of the day. Increasing the input spline to 35-splines solved that problem. The gears needed a size increase so the gear pitch diameter was increased a 9-1/2" patter. It's to be noted that the physical diameter of the ring gear is 9-1/4" Some of the edge material was removed to fit in the current aftermarket housings. The latest change is increasing the pitch diameter pattern to a 10" pattern. The actual ring gear measures 9-7/16" diameter. Another improvement was to change the balance of the ring gear tooth thickness to pinion gear thickness to balance the stresses. The pinion support for the 10" ring and pinions is different from the 9"-9-1/2" gears. This is to accommodate the larger distance from the ring gear center to the rear pinion bearing (mounting distance) on the larger 10" pattern.

## WHAT GEAR RATIO IS RIGHT FOR MY CAR?

The answer to this often asked question is easier than you might think. The Mark Williams Gear Ratio Calculator allows you to insert 3 of 4 variables, tire diameter, engine RPM, and MPH with the result being the final gear ratio required. You can also use it to determine the correct tire size or see how a tire size change will affect engine RPM and/or speed.



# 9" FORD GEARS

## 8620 STREET/OVAL TRACK GEARS '57-'73 Passenger Car - '57-'87 Light Trucks

1.313" dia. pinion stem 28 spline pinion

07-890300	3.00	9" Ford US Gear
07-890325	3.25	9" Ford US Gear
F890325	3.25	9" Ford Motive Gear
07-890350	3.50	9" Ford US Gear
629-0195	3.55	9" Ford Richmond Gear
629-0361	3.70	9" Ford Richmond Gear
07-890370	3.70	9" Ford US Gear
F890370	3.70	9" Ford Motive Gear
F890389	3.89	9" Ford Motive Gear
07-890389	3.89	9" Ford US Gear
07-890400	4.00	9" Ford US Gear
07-890411	4.11	9" Ford US Gear
629-0179	4.11	9" Ford Richmond Gear
F890411	4.11	9" Ford Motive Gear
07-890430	4.30	9" Ford US Gear
629-0161	4.33	9" Ford Richmond Gear
629-0185	4.56	9" Ford Richmond Gear
F890457	4.57	9" Ford Motive Gear
07-890457	4.57	9" Ford US Gear
07-890463	4.63	9" Ford US Gear
629-0379	4.63	9" Ford Richmond Gear
F890471	4.71	9" Ford Motive Gear
07-890471	4.71	9" Ford US Gear
629-0362	4.71	9" Ford Richmond Gear
07-890486	4.86	9" Ford US Gear
629-0067	4.86	9" Ford Richmond Gear
07-890500	5.00	9" Ford US Gear

629-0360	5.00	9" Ford Richmond Gear
07-890514	5.14	9" Ford US Gear
629-0068	5.14	9" Ford Richmond Gear
F890543	5.29	9" Ford Motive Gear
07-890529	5.29	9" Ford US Gear
629-0270	5.29	9" Ford Richmond Gear
F890543	5.43	9" Ford Motive Gear
07-890543	5.43	9" Ford US Gear
629-0069	5.43	9" Ford Richmond Gear
F890567	5.67	9" Ford Motive Gear
07-890567	5.67	9" Ford US Gear
629-0070	5.67	9" Ford Richmond Gear
F890583	5.83	9" Ford Motive Gear
07-890583	5.83	9" Ford US Gear
629-0288	5.83	9" Ford Richmond Gear
F890600	6.00	9" Ford Motive Gear
07-890600	6.00	9" Ford US Gear
629-0199	6.00	9" Ford Richmond Gear
F890620	6.20	9" Ford Motive Gear
07-890620	6.20	9" Ford US Gear
629-0290	6.20	9" Ford Richmond Gear
F890633	6.33	9" Ford Motive Gear
07-890633	6.33	9" Ford US Gear
629-0276	6.33	9" Ford Richmond Gear
F890650	6.50	9" Ford Motive Gear
07-890650	6.50	9" Ford US Gear
629-0197	6.50	9" Ford Richmond Gear

## 9310 DRAG RACE STANDARD PINION 9" PRO GEARS

1.313" dia. pinion stem 28 spline pinion

F990350SP	3.50	9" Ford Motive Small Pinion 9310
F990370SP	3.70	9" Ford Motive Small Pinion 9310
F990429SP	4.29	9" Ford Motive Small Pinion 9310
F990457SP	4.57	9" Ford Motive Small Pinion 9310
F990389SP	3.89	9" Ford Motive Small Pinion 9310
F990471SP	4.71	9" Ford Motive Small Pinion 9310
729-0066	4.86	9" Ford Richmond Small Pro 9310
07-990500	5.00	9" Ford US Small Pinion 9310
729-0078	5.00	9" Ford Richmond Small Pro 9310
F990514SP	5.14	9" Ford Motive Small Pro 9310
07-990514	5.14	9" Ford US Small Pinion 9310
729-0017	5.14	9" Ford Richmond Small Pro 9310
F990529SP	5.29	9" Ford Motive Small Pinion 9310
07-990529	5.29	9" Ford US Small Pinion 9310
729-0069	5.29	9" Ford Richmond Small Pro 9310

F990543SP	5.43	9" Ford Motive Small Pinion 9310
07-990543	5.43	9" Ford US Small Pinion 9310
729-0005	5.43	9" Ford Richmond Small Pro 9310
F990567SP	5.67	9" Ford Motive Small Pinion 9310
07-990567	5.67	9" Ford US Small Pinion 9310
729-0007	5.67	9" Ford Richmond Small Pro 9310
F990583SP	5.83	9" Ford Motive Small Pinion 9310
07-990583	5.83	9" Ford US Small Pinion 9310
729-0019	5.83	9" Ford Richmond Small Pro 9310
07-990600	6.00	9" Ford US Small Pinion 9310
F990620SP	6.20	9" Ford Motive Small Pinion 9310
07-990620	6.20	9" Ford US Small Pinion 9310
07-990633	6.33	9" Ford US Small Pinion 9310
F990650SP	6.50	9" Ford Motive Small Pinion 9310
07-990650	6.50	9" Ford US Small Pinion 9310
729-0054	6.50	9" Ford Richmond Small Pro 9310



# 9" FORD PRO GEARS

## 9310 DRAG RACE LARGE PINION PRO 9"GEARS

1.875" dia. pinion stem 35 spline pinion

07-990340	3.40	9" Ford US Large Pinion 9310
07-990350	3.50	9" Ford US Large Pinion 9310
729-0002	3.50	9" Ford Richmond Large Pinion 9310
07-990360	3.60	9" Ford US Large Pinion 9310
729-0003	3.60	9" Ford Richmond Large Pinion 9310
F990370BP	3.70	9" Ford Motive Large Pinion 9310
07-990370	3.70	9" Ford US Large Pinion 9310
729-0004	3.70	9" Ford Richmond Large Pinion 9310
F990370BP	3.70	9" Ford Motive Large Pinion 9310
07-990389	3.89	9" Ford US Large Pinion 9310
729-0043	3.89	9" Ford Richmond Large Pinion 9310
F990411BP	4.11	9" Ford Motive Large Pinion 9310
07-990411	4.11	9" Ford US Large Pinion 9310

729-0045	4.11	9" Ford Richmond Large Pinion 9310
F990429BP	4.29	9" Ford Motive Big Pinion 9310
07-990429	4.29	9" Ford US Large Pinion 9310
729-0079	4.29	9" Ford Richmond Large Pinion 9310
F990457BP	4.57	9" Ford Motive Large Pinion 9310
07-990457	4.57	9" Ford US Large Pinion 9310
729-0080	4.57	9" Ford Richmond Large Pinion 9310
07-990471	4.71	9" Ford US Large Pinion 9310
729-0070	4.71	9" Ford Richmond Large Pinion 9310
F990486BP	4.86	9" Ford Motive Large Pinion 9310
07-990486	4.86	9" Ford US Large Pinion 9310
729-0060	4.86	9" Ford Richmond Large Pinion 9310

# 9-1/2" FORD PRO GEARS

## 9310 DRAG RACE LARGE PINION 9-1/2"PRO GEARS

1.875" dia. pinion stem 35 spline pinion (unless noted otherwise noted))

U9.5F-2.91	2.91	9-1/2 Hoosier 40 Spline Pinion
U9.5F-3.25	3.25	9-1/2" Ford US-Toms Large Pinion
07-995325	3.25	9-1/2" Ford US Gear Large Pinion
U9.5F-3.40	3.40	9-1/2" Ford US-Toms Large Pinion
07-995340	3.40	9-1/2" Ford US Gear Large Pinion
U9.5F-3.50	3.50	9-1/2" Ford US-Toms Large Pinion
07-995350	3.50	9-1/2" Ford US Gear Large Pinion
U9.5F-3.60	3.60	9-1/2" Ford US-Toms Large Pinion
07-995360	3.60	9-1/2" Ford US Gear Large Pinion
U9.5F-3.70	3.70	9-1/2" Ford US-Toms Large Pinion
U9.5F-3.89	3.89	9-1/2" Ford US-Toms Large Pinion
07-995389	3.89	9-1/2" Ford US Gear Large Pinion
U9.5F-4.11	4.11	9-1/2" Ford US-Toms Large Pinion
07-995411	4.11	9-1/2" Ford US Gear Large Pinion
729-0097	4.11	9-1/2" Ford Richmond Large Pinion
U9.5F-4.29	4.29	9-1/2" Ford US-Toms Large Pinion

F95/429-PRO	4.29	9-1/2" Ford Hoosier Large Pinion
07-995429	4.29	9-1/2" Ford US Gear Large Pinion
729-0098	4.29	9-1/2" Ford Richmond Large Pinion
U9.5F-4.57	4.57	9-1/2" Ford US-Toms Large Pinion
07-995457	4.57	9-1/2" Ford US Gear Large Pinion
729-0101	4.57	9-1/2" Ford Large Pinion 9310
U9.5F-4.86	4.86	9-1/2" Ford US-Toms Large Pinion
07-995486	4.86	9-1/2" Ford US Gear Large Pinion
U9.5F5.00	5.00	9-1/2" Ford US-Toms Large Pinion
07-995500	5.00	9-1/2" Ford US Gear Large Pinion
U9.5F-5.14	5.14	9-1/2" Ford US-Toms Large Pinion
07-995514	5.14	9-1/2" Ford US Gear Large Pinion
729-0108	5.00	9-1/2" Ford Richmond Std. Pinion 28 spline standard pinion
729-0111	5.20	9-1/2" Ford Richmond Std. Pinion 28 spline standard pinion

# GEAR LIGHTENING

## RING GEAR LIGHTENING

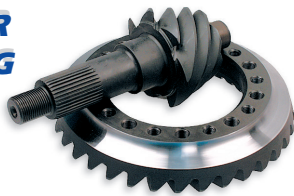

MW offers a special ring gear lightening service for 9" Ford, 12 bolt GM (4:88 to 6:20 ratio) and Dana 60 gears. This process is performed on a CNC lathe with special tooling to produce a generous radius and smooth finish. The result is a weight reduction of between 1/2 and 3-1/2 lbs. Some gears are factory lightened but we can remove additional weight in most cases.

LRG Lighten ring gear. (with gear purchase)

# 10" FORD PRO GEARS

## 9310 10" PITCH DIAMETER DEVELOPMENT (9.43 PHYSICAL RING DIAMETER)

The latest strength improvement for the 9" Ford rears. Requires matching case and pinion front bearing support. Can be used in most 9" Housings with extra clearance modifications. All have 35 spline input and 1/2" ring gear bolts. Fits 9" spools for 1/2" ring gear bolts

T10-370	3.70	10" Ford Tom's Gear	07-910471	4.71	10" Ford US Gear
T10-389	3.89	10" Ford Tom's Gear	T10-500	5.00	10" Ford Tom's Gear
07-910389	3.89	10" Ford US Gear	07-910500	5.00	10" Ford US Gear
T10-411	4.11	10" Ford Tom's Gear	T10-514	5.14	10" Ford Tom's Gear
07-910411	4.11	10" Ford US Gear	07-910514	5.14	10" Ford US Gear
T10-429	4.29	10" Ford Tom's Gear	07-910543	5.43	10" Ford US Gear
07-910429	4.29	10" Ford US Gear	07-910583	5.83	10" Ford US Gear
T10-457	4.57	10" Ford Tom's Gear	07-910620	6.20	10" Ford US Gear

# 9-1/2" MWE LOW FRICTION FORD GEARS

## 9310 PRO STOCK 32 SPLINE INPUT

As used in the MW Low Friction 57022 Thirdmembers 45mm rear pinion bearing ID, 32 spline pinion.

These gears are manufactured for MW by Velvet Drive, the original manufacturer for Richmond brand gears. The quality is the same as pre 2002 Richmond brand gears. The gears can be used in a Differential with the MW ball taper support with different spacers and a 32 spline pinion yoke. See catalog page 29 for the matching pinion support. These gears are available with Shot Peening and Super-Fin finishing options.

MWE-511	5.11	9-1/2" Low Friction Gear	MWE-529	5.29	9-1/2" Low Friction Gear
MWE-514	5.14	9-1/2" Low Friction Gear	MWE-533	5.33	9-1/2" Low Friction Gear
MWE-517	5.17	9-1/2" Low Friction Gear	MWE-538	5.38	9-1/2" Low Friction Gear
MWE-520	5.20	9-1/2" Low Friction Gear	MWE-543	5.43	9-1/2" Low Friction Gear
MWE-525	5.25	9-1/2" Low Friction Gear	MWE-550	5.50	9-1/2" Low Friction Gear

# MW 11" MODULAR GEARS

**9310 PRO GEAR MATERIAL** For 11" MW Modular Differential 14 ring gear bolts 9/16-18 thread

2.167" rear bearing dia. 40 spline input

729-0121	2.91	11" Modular Gear, Series 1 Spool	729-0116	4.29	11" Modular Gear, Series 2 Spool
729-0320	3.20	11" Modular Gear, Series 1 Spool	729-0117	4.57	11" Modular Gear, Series 2 Spool
729-0120	3.89	11" Modular Gear, Series 2 Spool	729-0124	4.71	11" Modular Gear, Series 2 Spool
729-0115	4.11	11" Modular Gear, Series 2 Spool	0124	5.83	11" Modular Gear, Series 2 Spool

**SERIES 1 GEARS USE 53104 SPOOL OR 90030 CARRIER, SERIES 2 GEARS USE 53108 SPOOL OR 90034 CARRIER**

**SPECIAL GEAR RATIOS ARE NOW AVAILABLE FOR THE MW 11" MODULAR REAR! CALL 1-800-525-1963 FOR MORE INFORMATION.**

# 8.8" FORD GEARS

## 8620 STREET GEARS

1.626" dia. pinion stem 30 spline pinion

07-888308	3.08	8.8" Ford US Gear 8620	07-888410	4.10	8.8" Ford US Gear 8620
2020743	3.08	8.8" Ford Spicer Gear 8620	629-0310	4.10	8.8" Ford Gear 8620
F888327	3.27	8.8" Ford Motive Gear 8620	F888430	4.30	8.8" Ford Motive Gear 8620
429-0103	3.55	8.8" Ford Richmond Gear 8620	629-0376	4.33	8.8" Ford Gear 8620
07-888355	3.55	8.8" Ford US Gear 8620	F888456	4.56	8.8" Ford Motive Gear 8620
F888373	3.73	8.8" Ford Motive Gear 8620	07-888456	4.56	8.8" Ford US Gear 8620
07-888373	3.73	8.8" Ford US Gear 8620	629-0312	4.56	8.8" Ford Gear 8620
429-0104	3.73	8.8" Ford Richmond Gear 8620	07-888471	4.71	8.8" Ford US Gear 8620
629-0311	3.89	8.8" Ford Richmond Gear 8620	F888488	4.88	8.8" Ford Motive Gear 8620
F888390	3.90	8.8" Ford Motive Gear 8620	07-888488	4.88	8.8" Ford US Gear 8620
07-888390	3.90	8.8" Ford US Gear 8620	629-0382	4.88	8.8" Ford Gear 8620
F888410	4.10	8.8" Ford Motive Gear 8620	07-888513	5.13	8.8" Ford US Gear 8620
			83-1043		Installation Kit, 8.8" Ford



## GM CAR 12 BOLT GEARS

1.625" dia. pinion stem 30 spline pinion, 4 series

### 8620 STREET OVAL TRACK GEARS

429-0094	<b>3.08</b>	12 Bolt Car Richmond 3 series
01-888308	<b>3.08</b>	12 Bolt Car US Gear 3 series
429-0113	<b>3.42</b>	12 Bolt Car Richmond 3 series
01-888342	<b>3.42</b>	12 Bolt Car US Gear 3 series
G888342	<b>3.42</b>	12 Bolt Car Motive 3 series
429-0095	<b>3.55</b>	12 Bolt Car Richmond 3 series
429-0039	<b>3.73</b>	12 Bolt Car Richmond 3 series
01-888373	<b>3.73</b>	12 Bolt Car US Gear 3 series
429-0096	<b>3.73</b>	12 Bolt Car Richmond 4 series
429-0040	<b>3.90</b>	12 Bolt Car Richmond 3 series
01-888391	<b>3.91</b>	12 Bolt Car US Gear 3 series
629-0304	<b>4.10</b>	12 Bolt Car Richmond 3 series
629-0031	<b>4.10</b>	12 Bolt Car Richmond 4 series
01-888411	<b>4.11</b>	12 Bolt Car US Gear 4 series
01-888430	<b>4.30</b>	12 Bolt Car US Gear 4 series

**3 SERIES CARRIERS 3.08 TO 3.73**

629-0378	<b>4.33</b>	12 Bolt Car Richmond 4 series
01-888456	<b>4.56</b>	12 Bolt Car US Gear 4 series
629-0306	<b>4.56</b>	12 Bolt Car Richmond 3 series
629-0032	<b>4.56</b>	12 Bolt Car Richmond 4 series
G888456	<b>4.56</b>	12 Bolt Car Motive 4 series
01-888488	<b>4.88</b>	12 Bolt Car US Gear 4 series
629-0033	<b>4.88</b>	12 Bolt Car Richmond 4 series
01-888514	<b>5.14</b>	12 Bolt Car US Gear 4 series
629-0034	<b>5.14</b>	12 Bolt Car Richmond 4 series
01-888538	<b>5.38</b>	12 Bolt Car US Gear 4 series•
629-0035	<b>5.38</b>	12 Bolt Car Richmond 4 series
629-0037	<b>5.86</b>	12 Bolt Car Richmond 4 series•
629-0038	<b>6.14</b>	12 Bolt Car Richmond 4 series•
83-1019		Installation Kit, GM Car 12 Bolt

**4 SERIES CARRIERS 3.90 AND NUMERICALLY HIGHER**

## GM CAR 12 BOLT PRO GEARS

1.625" dia. pinion stem 30 spline pinion, 4 series

### 9310 DRAG RACE PRO GEARS

729-0099	<b>4.11</b>	12 Bolt Car Richmond Pro Gear
729-0074	<b>4.33</b>	12 Bolt Car Richmond Pro Gear
01-988456	<b>4.56</b>	12 Bolt Car US Gear Pro Gear
729-0072	<b>4.56</b>	12 Bolt Car Richmond Pro Gear
01-988488	<b>4.88</b>	12 Bolt Car US Gear Pro Gear
729-0064	<b>4.88</b>	12 Bolt Car Richmond Pro Gear
01-988514	<b>5.14</b>	12 Bolt Car US Gear Pro Gear
729-0027	<b>5.14</b>	12 Bolt Car Richmond Pro Gear
01-988538	<b>5.38</b>	12 Bolt Car US Gear Pro Gear•

729-0029	<b>5.38</b>	12 Bolt Car Richmond Pro Gear•
01-988557	<b>5.57</b>	12 Bolt Car US Gear Pro Gear•
729-0031	<b>5.57</b>	12 Bolt Car Richmond Pro Gear•
01-988586	<b>5.86</b>	12 Bolt Car US Gear Pro Gear•
729-0033	<b>5.86</b>	12 Bolt Car Pro Gear•
01-988614	<b>6.14</b>	12 Bolt Car US Gear Pro Gear•
83-1019		Installation Kit, GM Car 12 Bolt
80-0269		Special cross pin for gears with •

## GM TRUCK 12 BOLT GEARS

1.437" dia. pinion stem 30 spline pinion

### 8620 STREET GEARS '64-'82 C10/K10 & K20, Blazer - G10/G20 Van

429-0068	<b>3.08</b>	GM Truck 12 Bolt - 3 series
429-0280	<b>3.73</b>	GM Truck 12 Bolt - 4 series

**3 SERIES CARRIERS 3.40 AND NUMERICALLY LOWER**

629-0204	<b>4.10</b>	GM Truck 12 Bolt - 4 series
83-1018		Installation Kit, GM Truck 12 Bolt

**4 SERIES CARRIERS 3.73 AND NUMERICALLY HIGHER**

## MW HI-EFFICIENCY GEARS

Replacement gears for the 67410 series Hi-Efficiency Thirdmembers (High Pinion). Made from 9310 material with the same hypoid distance (and efficiency) as the Dana 60 rears. Requires MW pinion support, case, and spool to utilize. 32 spline input.

98-401	<b>4.77</b>	Hi-Efficiency Pro Gear
98-400	<b>4.86</b>	Hi-Efficiency Pro Gear
98-405	<b>5.00</b>	Hi-Efficiency Pro Gear
98-406	<b>5.50</b>	Hi-Efficiency Pro Gear

98-403	<b>5.67</b>	Hi-Efficiency Pro Gear
98-402	<b>5.71</b>	Hi-Efficiency Pro Gear
98-404	<b>5.83</b>	Hi-Efficiency Pro Gear

## 8" FORD GEARS

**8620 STREET GEARS** '65-'79 Mustang - '67-'72 Cougar - '64-'72 Comet - '60-'72 Falcon & Fairlane .188" dia. pinion stem 25 spline pinion

429-0101 **3.55** 8" Ford Richmond Gear 8620

629-0065 **4.62** 8" Ford Richmond Gear 8620

429-0111 **3.80** 8" Ford Richmond Gear 8620

**8" FORD INSTALLATION KIT**

83-1015 Installation Kit, 8" Ford

## DANA 60 GEARS

**8620 STREET GEARS** '66-'73 Dodge & Chrysler w/Hemi - Various 3/4 ton trucks '67-'98 9 3/4" ring gear 1.626" dia. pinion stem 29 spline pinion

429-0130 **3.73** Dana 60 Richmond Gear

629-0054 **4.88** Dana 60 Richmond Gear

706033-1X **3.54** Dana 60 Spicer Gear

629-0057 **5.13** Dana 60 Richmond Gear

706033-2X **3.73** Dana 60 Spicer Gear

629-0146 **5.38** Dana 60 Richmond Gear

629-0052 **4.10** Dana 60 Richmond Gear

706033-8X **7.17** Dana 60 Spicer Gear

629-0053 **4.56** Dana 60 Richmond Gear

**9310 DRAG RACE PRO GEARS**

9 3/4" ring gear 1.626" dia. pinion stem 29 spline pinion

729-0011 **4.10** Dana 60 Pro Gear 9310

729-0068 **4.88** Dana 60 Pro Gear 9310

05-997430 **4.30** Dana 60 US Pro Gear

729-0013 **5.38** Dana 60 Pro Gear 9310

729-0077 **4.56** Dana 60 Pro Gear 9310

729-0041 **6.17** Dana 60 Pro Gear 9310

**DANA 60 INSTALLATION KIT**

83-1034 Installation Kit, Dana 60

## 8 3/4" MOPAR GEARS - 742 CASE

**8620 STREET GEARS** '57-'68 Dodge, Chrysler and Plymouth

1.750 dia. pinion stem 10 spline pinion

629-0375 **3.91** 8-3/4" Mopar Gear 1-3/4"

629-0047 **4.56** 8-3/4" Mopar Gear 1-3/4"

629-0045 **4.10** 8-3/4" Mopar Gear 1-3/4"

629-0048 **4.86** 8-3/4" Mopar Gear 1-3/4"

629-0046 **4.30** 8-3/4" Mopar Gear 1-3/4"

629-0145 **5.13** 8-3/4" Mopar Gear 1-3/4"

83-5310-S Installation Kit, 8 3/4" Mopar - 742

83-1037 Installation Kit, 8 3/4" Mopar - 742

## 8 3/4" MOPAR GEARS - 489 CASE

**8620 STREET GEARS** '69-'73 Dodge, Chrysler and Plymouth

1.875" dia. pinion stem 10 spline pinion

03-887355L **3.55** 8-3/4" Mopar US Gear 1-7/8"

629-0061 **4.57** 8-3/4" Mopar Gear 1-7/8"

03-887391L **3.91** 8-3/4" Mopar US Gear 1-7/8"

629-0062 **4.86** 8-3/4" Mopar Gear 1-7/8"

629-0059 **4.10** 8-3/4" Mopar Gear 1-7/8"

629-0063 **5.13** 8-3/4" Mopar Gear 1-7/8"

629-0060 **4.30** 8-3/4" Mopar Gear 1-7/8"

83-1031 Installation Kit, 8 3/4" Mopar - 489

## GM 8.5" 10 BOLT GEARS

**8620 STREET GEARS** '70-'76 Chevelle & Olds F85 - '70-'75 Chevy II - '70-'81 Camaro/Firebird/GTO

1.625" dia. pinion stem 30 spline pinion

429-0278 **3.42** GM 8.5" 10 Bolt

629-0169 **4.88** GM 8.5 10 Bolt

429-0041 **3.73** GM 8.5" 10 Bolt

629-0171 **5.13** GM 8.5 10 Bolt

629-0165 **4.10** GM 8.5" 10 Bolt

83-1021 Installation Kit, GM 8.5" 10 Bolt

629-0167 **4.56** GM 8.5 10 Bolt

**ALL GEARS FIT 3 SERIES CARRIERS (2.73 AND NUMERICALLY HIGHER) OR MW SPOOL**

**MARK WILLIAMS Enterprises®**

# DIFFERENTIAL RING GEAR CLEARANCE GAUGE

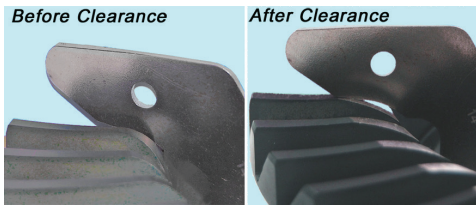

The Ring Gear Toe Clearance Gauge is available to check the 9", 9-1/2" and 10" gear sets for clearance required for M-W 9" cases.

Designed to eliminate the trial and error method of forming the gear toe profile to clear the pilot bearing housing area. Clearancing the gear eliminates the error-prone practice of grinding the inside of the case, which almost always results in the case cracking while in-service. This gauge is a standard tool used by our professional differential assembly technicians.

P/N 57486

## GEAR IMPROVEMENTS

### SUPRA-FIN SURFACE IMPROVEMENT

MW offers Supra-Fin surface finish improvement for ring and pinion sets. This fine micro finishing process reduces friction and eliminates the need for break-in procedures required to assure a long gear life. We exclusively protect the mounting and bearing surfaces so this process will not alter the installation fit.

SUPRA-FIN



### SHOT PEENING

This surface improvement decreases the likelihood of cracks forming on the gear.

Nearly all fatigue cracks begin at the surface of the part. By overlapping the dimples of the media, Shot-Peening creates a compression zone at the surface of the part. This layer acts as a barrier to crack propagation. The peening process provides a considerable increase in part life.

PEEN-02 Shot Peen Gear Set

### SUB ZERO TREATMENT

In addition to other gear improvement processes offered by Mark Williams, there is now sub zero process to improve gear wear characteristics. Cold treating a ring and pinion improves the metal crystal structure, decreasing the amount of retained austenite. This process can increase the gear life.

SUBZ Sub Zero Treatment

## TORCO GEAR OIL



Torco GL-6 Racing Gear oil has proven to be ideal for drag racing and oval track applications. SAE 85W-140 can be used when running a spool, posi-traction or open differentials. It provides superior adhesive strength and extreme anti-score protection. In addition, the Torco gear oil available from MW is specially blended to include the friction modifying additives required for most clutch type posi-traction units. Available by the quart or 12 quart case. **Look for the MW logo on the label.**

55-0030 Torco SAE 85-140 Gear Oil (1 qt)

55-0040 Torco SAE 85-140 Gear Oil(12 qts)

## RING AND PINION SET-UP VIDEOS



MW offers two educational installation videos. The MW video explains in step-by-step detail the set-up of a MW 9" aluminum center section. The Richmond Gear video is designed for basic ring and pinion gear set-ups. The Richmond video explains gear terminology and basic setup procedures for popular passenger car rear ends including 9" Ford, 10/12 Bolt Chevrolet, Dana 60 and 8 3/4" Mopar. Both videos are a must for rear end set-ups

629-0000 Richmond Gear DVD Video

10098 MW 9" Ford Assembly DVD Video

**Now All  
Available on  
DVD!**

## DIFFERENTIAL ASSEMBLY TOOLS

One of the handiest shop tools is the M/W Bench Mule. The "Mule" is a very sturdy and versatile fixture capable of holding differentials, transmissions, cylinder heads, etc. for assembly. Being able to securely position your work is essential. With two axis adjustment and heavy duty steel construction the MW Bench Mule makes tough jobs much easier to handle. The standard arms will easily hold a thirdmember or transmission and can even hold a full size 12 bolt housing. Optional attachments include short arms for cylinder head assembly work. The 670 Spool holding attachment bolts to the vise arms to hold either a 35 or 40 spline spool while tightening the ring gear bolts. Another option is to utilize a regular bench vise and the 57492 Spool holder with both 35 and 40 tooth splines. Both these tools have the 35 spline side sized that so it will work with either 45° or 30° pressure angle splines.

- 650 Bench Mule

---

- 670 Spool Holding Fixture (35 & 40 spline)

---

- 680 Cylinder Head Holding Forks (6-3/8" centers)

---

- 57492 Spool Holder, 35 & 40 spline (for vise)



## SETTING THE PINION DEPTH

Pinion depth is easily the most important element of correctly setting up a ring and pinion. The T&D pinion depth checker, used by many leading shops and racers, is easy to use and allows you to precisely set pinion depth. This deluxe kit has the components required for checking the most popular rears including 10 & 12 Bolt GM, Dana 60, 8.8 & 9" Ford and 8 3/4 Mopar rears. All components are stored in the included plastic carrying case to prevent damage. This is a very popular item and it works very well on a large variety of rears. Unfortunately it will not work on Mark Williams aluminum and nodular cases due to the captive pilot bearing area. Use PCMW for MW cases.

- PCD T&D Deluxe Pinion Depth Checker



## PINION DEPTH CHECKER 9" CASES

MW 9" cases have increased material behind the pilot bearing. This prevents the use of the PCD pinion depth checker or similar tools that must have access to the tip of the pinion. There is an alternate method to obtain the shim required. All you need to know is the distance from the end of the pinion pilot stem to the flange of the support. With that value you can calculate the shim required. The 1" travel dial indicator and precision calibration standard are included. It can be used on any 9" case as long as the case is 6.00" (the normal distance) from the mounting flange to the spool centerline. This is an easier method to determine the correct shim.

- PCMW Pinion Depth Checker Tool
- Works with M/W aluminum or nodular iron cases or other accurate cases. Works in 3.25 to 6.50 ratios*



## SPECIALTY SET-UP TOOLS

- 300-2 Safety Wire Twist Pliers, 9" length

---

- 55-0002 Gear Marking Compound (small packet)

---

- 57485 Adjuster Wrench, 3.812 case

---

- 57488 Coupler/Yoke Wrench

---

- 57490 Adjuster Wrench, 3.062 & 3.250 cases

---

- 57493 Bearing Puller (standard pinion)

---

- 57494 Bearing Puller (large pinion)

---

- 57499 Blacklash Indicator Kit (made in USA)

---

- 90250 Slide Hammer (aluminum cap removal)

These tools include a wrench to hold either a female pinion coupler or 1350 series yoke while tightening/torquing the pinion nut, Sockets for back lash adjusters, Safety wire twist pliers, Backlash Dial Indicator kit and Pinion bearing pullers.





# HI-EFFICIENCY THIRDMEMBER ASSEMBLY

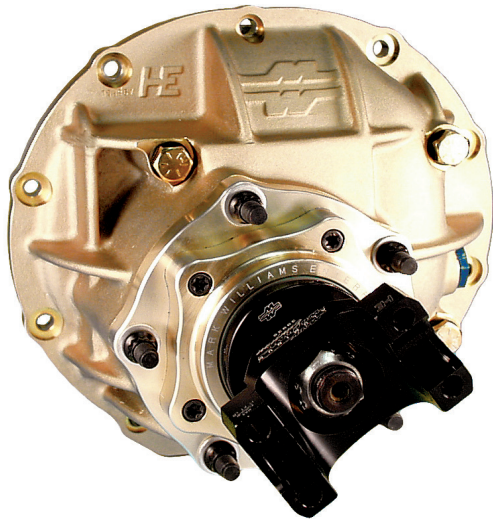

- SUPRA-FIN™ POLISHED GEARS
- ALUMINUM PINION YOKE
- LOW-FRICTION SEAL
- ALUMINUM 40-SPLINE SPOOL
- SURE-LOCK™ ADJUSTER SYSTEM
- 32-SPLINE PINION INPUT

The Hi-Efficiency Thirdmember is a raised pinion version of the conventional 9" unit.

The ring and pinion gear has the same pinion offset as a Dana 60™ and as a result, benefits from the same efficiency the Dana 60 is known for.

The ideal applications are lightweight cars (2200# max) and with power limited up to 1000 HP. The units have proven successfully in competition eliminator cars.

The aluminum housing features the thru-bolt design similar to the MW 9" aluminum case. It also features a double angular contact front pinion support for reduced friction. It will fit in the regular and modular 9" housing that are prepared to accept the 9-1/2" ring gears.

Pro Gears featuring 9310 alloy are used in the specially assembled thirdmembers. They all feature a 32-spline pinion for additional strength.

The following ratios are available: 4.77, 4.86, 5.00, 5.50, 5.67, 5.71, and 5.83. All units come with our 40-spline aluminum spool and your choice of a billet aluminum u-joint yoke or coupler. A computer pick-up ring is included.

The gears in the assembly features our Supra-Fin™ processing that reduces friction and eliminates material transfer normally found in the break-in process. Our expert assembly technicians meticulously assemble each unit documenting all critical settings.

67410-XXX Hi-Efficiency Thirdmember Assembly  
Specify ratio, 32-spline input, u-joint, yoke, or coupler.

## HOUSING GASKETS AND TRANSPORTER



This gasket fits all 9" housings and allows for the clearance required for 9-1/2" and 10" increased diameter gears. It is coated with an EZ-Release seal ring that allows repetitive use. The 9" thirdmember transporter is the convenient way to store your spare Thirdmembers. These also double as a convenient way to ship the thirdmembers with a double wall-shipping carton and foam pad.



57929 Thirdmember Gasket with Tec-N -Seal  
Fit all 9" type housing with clearance for large gears

57999 Transporter for 9" type Thirdmembers  
Makes keeping your spare thirdmember clean and dry easy.

57999A Shipping Carton and two 12 x 12 x 1 pads

## GIBBS™ Brand Corrosion Inhibitor



Mark Williams Enterprises has long been searching for a product that provides better corrosion resistance than commonly used WD-40 oil. M/W has always been skeptical of products with miracles through chemistry. However, GIBBS© brand lubricant is the exception, and lives up to its claims. This product is the best bet for keeping unpainted dragster chassis tubing from rusting. It keeps driveline parts corrosion free without plating or painting.

Please take note: GIBBS™ Brand USA products have no affiliation with Joe Gibbs Racing or Joe Gibbs Racing oils.

55-0070 Gibbs Corrosion Inhibitor

(single)

(4 cans)

(case 12 cans)

# MWE 9-1/2" Low Friction Ford Thirdmembers

Special ratio Pro Gears are available in specially prepared thirdmember assemblies. These assemblies feature MW designed 9-1/2" ratios produced by Velvet Drive (formerly Richmond Gear) .

The ratios available in the 9310 alloy 32 spline pinion are: 5.11, 5.14, 5.17, 5.20, 5.25, 5.29, 5.33, 5.38, 5.43 and 5.50. This assembly can also be built with standard 9" and 9-1/2" Small 28 spline Pinion Pro-Gear ratios utilizing the same components.

The assemblies feature the Supra-Fin™ processing that reduces friction and eliminates material transfer normally found in the break-in process. We also use a Sub-Zero thermo-treatment to eliminate the possibility of retained austenite. Most assemblies feature 9-1/2" diameter gear with a 32 spline input (the same size as transmissions) eliminating an obvious weak link in the drive system.

We use a ceramic dual opposed angular contact bearing pinion support that is lighter, while reducing friction and adding rigidity to the pinion. A low drag pinion seal, used in conjunction with our aluminum pinion yoke reduces the pre-load drag to about 5 inch pounds.

The proven MW Thru-Bolt case features the Sure-lock™ adjuster system that makes other retention methods obsolete and prevents adjuster back out. All units include a computer pickup ring with one, two or four magnets. Our expert assembly technician meticulously assembles each unit documenting all critical settings.

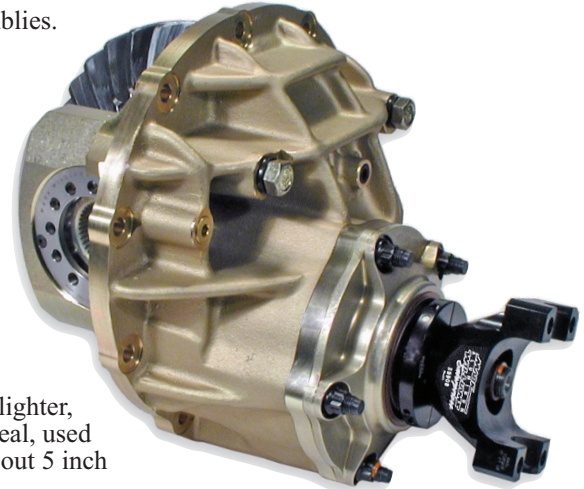

- POCKET LIGHTENED RING GEAR
- SUPRA-FIN™ FINISHED GEARS
- CERAMIC PINION SUPPORT BEARINGS
- ALUMINUM PINION YOKE
- LOW-FRICTION SEAL
- ALUMINUM 40 SPLINE SPOOL
- SURE-LOCK™ ADJUSTER SYSTEM
- 32-SPLINE PINION INPUT 9-1/2" GEAR
- SUB-ZERO TREATED RING AND PINION
- LOW DRAG ASSEMBLY PROCEDURES

## 57022-XXX Low Friction 9-1/2" Thirdmember

5.11 thru 5.50 Ratio, Sub-Zero, Supra-Fin treated 9-1/2" gears, specify ratio required. 32 spline input.

## 57022 Low Friction 9" & 9-1/2" Thirdmember

Units built with same component technology but ring and pinion gears will be 9" or 9-1/2" 28 spline input. 3.50 to 6.50 ratio 9310 gear. Prices vary with different ratios. Please call for pricing on specific ratios.

# 10" SEVERE SERVICE FORD THIRDMEMBER

Oversize 4.000" Angular Contact Spool Bearings

Extra clearance for 10" gear

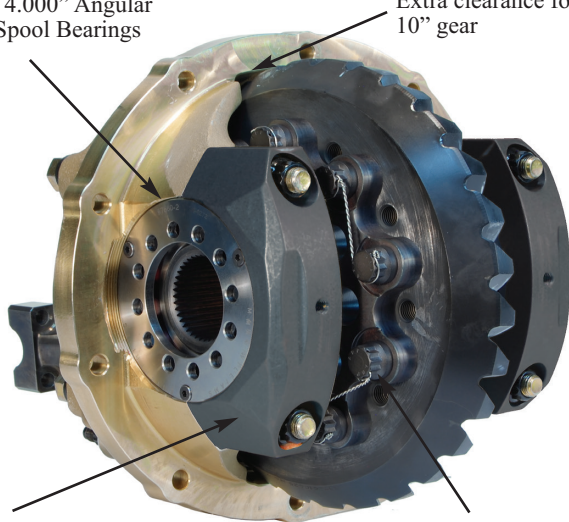

Aluminum or steel cap versions

Special ARP produced bolts with safety wire

The 10" ring and pinion gear sets have shown to dramatically increase gear life compared to 9" gears. Modifications have been made to the M/W Aluminum thru bolt, (V revision and later) case to accommodate the larger gears. Additionally the main bearing bores have been increased to a 4.000" diameter bore that is paired with special M-W angular contact ball bearings. Tests have shown that the angular contact bearings are better at deflection control than tapered roller bearings. Thirdmember assemblies are available with 3.70 to 6.20 gear ratios. More new ratios are currently in development. One option available is full ceramic ball bearings. These thirdmembers are a drop in fit for M/W Modular housings. Other housing may require clearance for the larger outside diameter gear.

## 57026 Thirdmember, 10" Pro Gear

10" ring and pinion, ball-taper support, steel caps, steel spool, 1480 or 1350 u-joint, 3.812" bore. Timken® bore tapered spool bearings

## 57027 Thirdmember, 10" Pro Gear

10" ring and pinion, ball-ball support, aluminum caps, steel or aluminum spool, 1480 or 1350 u-joint, angular contact 4" bore spool bearings

\*Prices can vary due to different pricing of ring and pinion gears sets from various manufacturers



# 9" & 9-1/2" FORD THIRDMEMBERS



For over the past three decades, Mark Williams Enterprises has continually improved the effectiveness and reliability of our 9" Ford assemblies. We have introduced new and improved components, developed specialized tooling, and created detailed processes to ensure that our 9" Ford Thirdmembers are the best money can buy. We offer three different styles of thirdmember cases and several different types of pinion supports to cover almost any application. Assemblies can be built with nodular iron, lightweight aluminum, or rugged thru-bolt style aluminum with several bore sizes to match the spool/carrier required. Pinion Supports are available with tapered bearings or angular contact ball bearings. The experts at Mark Williams can also assemble any of our Thirdmembers to meet your exact needs. We insure the accuracy of all critical operations by utilizing numerous specialized tools and applying over forty years of experience with 9" Ford carriers. Our attention to detail is reflected in every MW assembly and is evident even in the special transport containers supplied to ensure safe shipping and handling.

## DOOR CAR THIRDMEMBERS, U-JOINT YOKE

- 57003 Super Class/E.T. Bracket Assembly  
Aluminum thru bolt case (3.250 bore), lightweight steel spool, MW 28 spline 1350 series pinion yoke, ball-tapered bearing support, 4:86 to 6:50 US Gear 9" std. pinion Pro Gear. (58#)
- 57004 Street Rod Assembly  
Aluminum light weight case (3.062 bore), Posi Unit, MW 1330 or 1350 pinion yoke, tapered pinion support, 3:00 to 6:50 US Gear 9" 8620 gear. (70#)
- 57005 Street/Oval Track Assembly  
Nodular iron case (3.062 bore), 28 or 31-spline Detroit Locker, MW 1330 or 1350 pinion yoke, tapered support, 3:00 to 6:50 US Gear 9" 8620 gear. (75#)
- 57007 E.T. Bracket/Oval Track Assembly  
Nodular iron case (3.250 bore), standard spool (28, 31, 35 or 40 spline), 1350 MW pinion yoke, tapered support, 3:00 to 6:50 US Gear 9" 8620 gear. (72#)
- 57008 Super Class/E.T. Bracket Assembly  
Aluminum thru bolt case (3.250 bore), 35 Spline lightweight steel spool, MW 35 spline 1350 series pinion yoke, ball-tapered bearing support, 3:40 to 4:86 US Gear large pinion 9" Pro Gear. (58#)
- 57009 Pro Stock Assembly, Large Pinion  
Aluminum thru bolt case (3.812 Bore), 40 spline aluminum spool, MW 35 spline 1350 series pinion yoke, ball-tapered bearing support, 3:40 to 4:86 US Gear large pinion 9" Pro Gear.
- 57011 Pro Modified Assembly 9"  
Aluminum thru bolt case (3.812 bore), 40 spline lightweight steel spool, MW 35 spline 1350 series pinion yoke, ball-tapered bearing-support, 3:40 to 4:86 US Gear large pinion 9" Pro Gear. (62#)
- 57014 9-1/2" Pro Stock Assembly  
Aluminum thru bolt case (3.812 Bore), 40 spline aluminum spool, MW 1350 series pinion yoke, ball-tapered bearing support, 3.25 to 5.20 ratio US Gear 9-1/2" Pro Gear.

- 57015 Pro Street Assembly  
Aluminum thru bolt case (3.250 bore), 35 spline locker (nodular), MW 28 spline 1350 series pinion yoke, tapered bearing support, 3.00 to 6.50 ratio US Gear 9" 8620 gear. (75#)
- 57019 Pro Stock Assembly  
Aluminum thru bolt case (3.812 Bore), 40 spline aluminum spool, MW 28 spline 1350 series pinion yoke, ball-taper bearing support, 4:86 to 6.50 US Gear 9" std. pinion Pro Gear.
- 57021 9-1/2 Pro Modified Assembly  
Aluminum thru bolt case (3.812 bore), 40 spline lightweight steel spool, MW 35 spline 1350 series pinion yoke, ball-tapered bearing support, 1/2" ring gear bolts, 3.25 to 4:86 US Gear large pinion 9-1/2" Pro Gear. (68#)

## DRAGSTER/ALTERED THIRDMEMBERS, COUPLER

- 57001 Pro Dragster Assembly  
Aluminum thru bolt case (3.250 bore), lightweight steel spool, 28 spline female pinion coupler, ball-tapered bearing support, 4.86 to 6.50 9" US Gear std. pinion Pro Gear. (58#)
- 57002 Pro Dragster Assembly  
Aluminum thru bolt case (3.250 bore), lightweight steel spool, 35 spline female pinion coupler, ball-tapered bearing support, 3:40 to 4:86 9" Richmond large pinion Pro Gear. (61#)
- 57010 Top Dragster Assembly  
Aluminum thru bolt case (3.812 bore), 40 spline lightweight steel spool, 35 spline female pinion coupler, ball-tapered bearing support, 3:40 to 4:86 US Gear large pinion 9" Pro Gear. (58#)
- 57012 Superlite Econo/Comp Assembly  
Lightweight aluminum case (3.250 bore), 35 spline aluminum spool, ball-tapered bearing support, female pinion coupler, lightened 9" 8620 standard Gear. (49#)
- 57013 9-1/2" Alcohol Dragster-F/C Assy .  
Aluminum thru bolt steel cap case (3.812 bore), 40 spline lightweight steel spool, 35 spline female pinion coupler, ball-tapered pinion support, 1/2" ring gear bolts, US Gear lrg pin. 9-1/2" Pro Gear. (62#)

# FORD THIRDMEMBERS OPTIONS

- MW Aluminum Pinion Yoke . . . . .Price on Request
- 57463 Case Modification for Internal Pump  
Allows usage of 57466 Internal Pump Kit
- 57466 Internal Lubrication Pump Kit Option
- CB Ceramic Bearing Upgrades
- LRG Lighten Ring Gear

- PEEN-02 Shot Peen Ring and Pinion .
- SUBZ Gear Cold Process
- Supra-Fin™ Ring and Pinion Surface Improvement
- 57999 Transport Carrier, 9" Ford  
No charge when purchasing Thirdmember

# 9" FORD CASES

**ALUMINUM THRU-BOLT** - This highly refined, heavy-duty unit has become the "standard" in champion caliber Drag Race cars. It weighs 11 lbs. less than our nodular iron carrier. The unique thru bolt design and the use of an ultra strong A206 alloy with engineered cross sections give it superior strength. The MW Thru-Bolt™ cases with cap aligning bushings create better compressive strength and maintaining the main cap alignment. The pinion pilot-bearing bore utilizes an extra long bearing that is completely captive, retained by screw fasteners. 7075 aluminum or Steel caps are utilized with billet steel adjusters and 7/16" pinion support stud kit are included. Bore sizes available are 3.062", 3.250", 3.812" and new 4.00" bore. The 3.812" and 4.00" bore cases features "Grip-Lock™" adjusters lock system. All the MW thru bolt cases are cleared for 9-1/2" (9-1/4" actual diameter) through 10" (9-7/16" actual diameter) gears. Fluid passage ports for external and internal lubrication systems are pre-drilled.

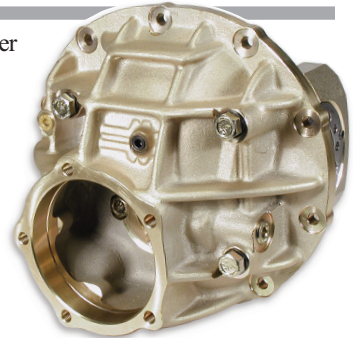

57430 9" Ford Thru-Bolt Aluminum Case

3.062" bore w/aluminum caps and adjusters. 16.5 lbs.

57440 9" Ford Thru-Bolt Aluminum Case

3.250" bore w/aluminum caps and adjusters. 16.4 lbs.

57448 9" Ford 3.812" 9-1/2" -10" Gear Case

3.812" bore thru bolt case w/aluminum caps and adjusters. (3.812 bore size for spools and carriers with 2-1/4" ID bearings) 16.2 lbs.

57448-95S 9" Ford Big Bore 9-1/2" -10" Gear Case

Same as 57448 but with steel billet caps. 19.6 lbs.

57458 9 1/2"-10" Ford 4" Bore, Aluminum Caps

For 4.00 bore angular contact ball main bearings, 15.9 lbs.

57458-10S 9 1/2"-10" Ford 4" Bore, Steel Caps

For 4.00 bore angular contact ball main bearings, 19.4 lbs.

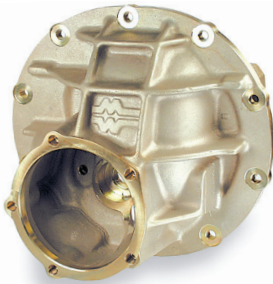

**LIGHT WEIGHT ALUMINUM** - The MW Light Weight case is based on the MW nodular case design and is cast from the same material used in the MW thru-bolt cases, but does not have the additional reinforcing and heavier walls of a thru-bolt case. The case should only be used in lighter drag racing and street applications. The MW Light Weight case is 5 lbs. lighter than a thru-bolt case and over 15 lbs. lighter than an OEM nodular case. It can also be used in street or oval track applications.

57415 9" Ford Light Weight Case

3.062" bore with aluminum caps and adjusters. 11.5 lbs.

57425 9" Ford Light Weight Case

3.250" bore with aluminum caps and adjusters. 11.5 lbs.

**NODULAR IRON** - The MW nodular iron case features a improved case design that provides necessary reinforcement in all critical areas, yet is comparable in weight to a stock unit while lighter than competitors. Each MW nodular iron case comes with billet steel caps with ARP studs and nuts. Billet steel adjusters with studs for the pinion assembly. 3.062" or 3.250" bore sizes available.

57460 9" Ford MW Nodular Case

3.062" bore with steel caps and adjusters. 29 lbs.

57470 9" Ford MW Nodular Case

3.250" bore with steel caps and adjusters. 29 lbs.

57465 9" Ford MW NASCAR Case

3.062" bore with pump mounts and fluid ports. Load bolt provision, 3/8-16 threads for pinion support, lightened main caps. 27.7 lbs.

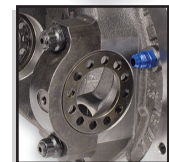
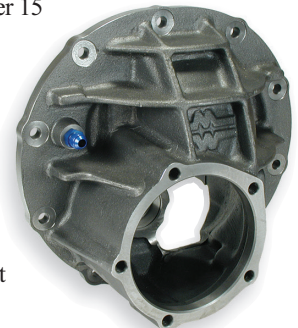

57465 NASCAR Case

## INTERNAL LUBRICATION



Internal lubrication pumps pressure feed oil to areas that become starved from acceleration forces. The pump is internally mounted to the thirdmember case (special machining required). Circle track applications use the pump for flow to an oil cooler with the return flow providing cooling and lubrication.

57466 Internal Oil Pump Kit

Pump mounts to pinion pilot bearing area, includes hard line and case fitting. (external lines extra)

57463 Case Modifications for Pump

Machining required to mount internal pump. 57465 and 57448-95P are pre machined for pump. (not required for 57465 case)

## THRU-BOLT FEATURES

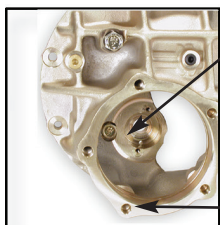

**POSITIVE PILOT BEARING RETENTION**  
**THRU-BOLT CONSTRUCTION**  
**7/16 THREADS IN CASE**

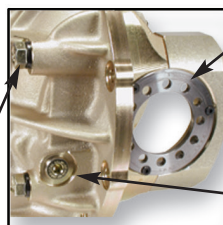

**GRIP-LOCK™ STEEL ADJUSTERS**  
**7075 T651 ALUMINUM CAPS**  
**THREADED FOR OPTIONAL LOAD BOLT**

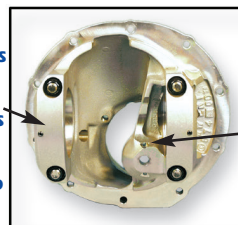

**GRADE 9 BOLTS WITH ALIGNMENT BUSHINGS AND REDUCED HEX NUTS**  
**PILOT BEARING REMOVAL HOLES**  
**OPTIONAL INTERNAL PUMP**

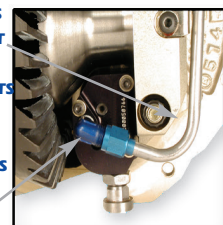

## 9" FORD ALUMINUM PINION SUPPORT



57620

57680

### 28 Spline Input 9"- 9-1/2" Gear

47675 Pinion Bearing Housing, Ball/Ball  
9" & 9-1/2" Ford 28 spline pinion gears, with dual angular contact bearings. .

57620 Pinion Bearing Housing Assy Taper/Taper  
9" Ford standard 28 spline pinion gears, with tapered bearings.

57670 Pinion Bearing Housing Assy, Ball/Taper  
9" Ford standard 28 spline pinion gears, with angular contact rear bearing. Timken tapered front.

### 32 Spline Input - 9-1/2" Gear

57675 Pinion Bearing Housing Assy, Ball/Taper  
MW 32 spline pinion gears, with angular contact rear bearing, Timken tapered front.

### 35 Spline Input 9"- 9-1/2" Gear

47680 Pinion Bearing Housing, Ball/Ball  
9" & 9-1/2" Ford 35 spline large pinion Pro gears, with dual angular contact bearing.

57630 Pinion Bearing Housing, Taper/Taper  
9" Ford 35 spline large pinion Pro gears, with tapered bearings.

MW offers several models of pinion support assemblies for 9", 9-1/2" and 10" differentials. The MW upgraded pinion support uses Timken® tapered bearings that have much higher load capacity than the OEM units. Part numbers 57620 and 57630 feature dual tapered bearings and improved strength. The next improvement increased RPM limits to match requirements of higher revving motors by upgrading to a rear angular contact ball bearing. This eliminated issues with the large rear tapered bearing lowering maximum RPM's. An added bonus is the frictional drag verses load applied is improved with rear angular contact bearings. The newest assemblies feature a dual angular contact ball bearings. These units have a special front bearing and retainer that allow the race to be removed for setting the preload. A common upgrade for angular contact bearing is to change to ceramic balls that are stiffer, lighter, and have an increased RPM rating. All supports require input yoke match wider bearing assembly. Stock yokes can be shortened to fit.

57680 Pinion Bearing Housing Assy, Ball/Taper  
9" & 9-1/2" Ford 35 spline large pinion Pro gears, with angular contact rear bearing Timken front

### 35 Spline Input 10" Gear

47679 Pinion Bearing Housing Assy, Ball/Ball  
10" Ford 35 spline pinion Pro gears, with dual angular contact bearings

57679 Pinion Bearing Housing Assy, Ball/Taper  
10" Ford 35 spline large pinion Pro gears, with angular contact rear bearing, Timken front.

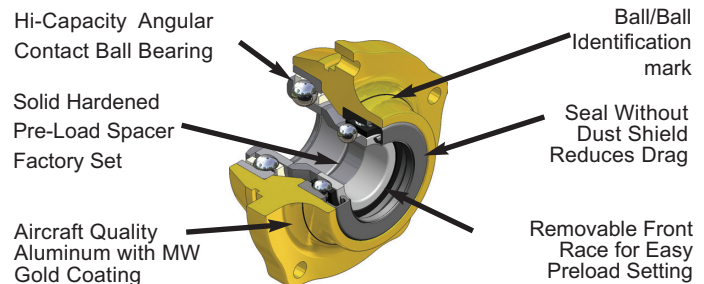

47XXX Series Supports

## 9" FORD CERAMIC BEARING PINION SUPPORTS

CB-47675 Ceramic Ball/Ball Pinion Support  
9" & 9-1/2" Ford 28 spline pinion Pro gears, with dual ceramic angular contact bearings. Requires MW yoke or coupler.

CB-47679 Ceramic Ball/Ball Pinion Support  
10" Ford 35 spline pinion Pro gears, with dual ceramic angular contact bearings.

CB-47680 Ceramic Ball/Ball Pinion Support  
9" & 9-1/2" Ford 35 spline large pinion Pro gears, with dual ceramic angular contact bearing.

CB-57670 Ceramic Ball /Tapered Bearing  
For 9" Ford standard 28 spline pinion gears, with ceramic angular contact rear bearing. Timken tapered front.

CB-57675 Ceramic Ball /Tapered Bearing  
For MWE 32 spline pinion gears, with ceramic angular contact rear bearing, Timken<sup>R</sup> tapered front.

CB-57679 Ceramic Ball /Tapered Bearing  
For 10" Ford 35 spline large pinion Pro gears, with ceramic angular contact rear bearing, Timken<sup>R</sup> tapered front.

CB-57680 Ceramic Ball /Tapered Bearing  
For 9" & 9-1/2" Ford 35 spline large pinion Pro gears, with angular contact rear bearing. Timken<sup>R</sup> tapered front.

## 9" FORD NODULAR PINION SUPPORT

57690 Nodular Iron Ball Bearing Pinion Support  
Ball angular contact rear bearing Timken<sup>R</sup> tapered front, Pre-Set.

CB-57690 Nodular Iron Ceramic Ball Bearing Pinion Support  
Ceramic balls angular contact rear bearing Timken<sup>R</sup> tapered front, Pre-Set



# 9" FORD SPOOLS

Profile milling & lightening holes

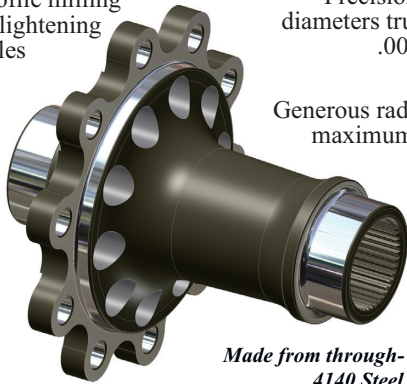

Precision ground diameters true within .001" T.I.R.

Generous radiuses for maximum rigidity

Made from through-hardened 4140 Steel

53125

## Light Weight Spools

53145 9" Ford Light Weight Spool  
MW 35-spline, L/W milled for stock case, 2.983" or 3.062" bore, weight 8.75 lbs.

53148 9" Ford Light Weight Spool  
MW 35-spline, L/W milled 3.250" case, weight 9 lbs.

53125 9" Ford Light Weight Spool  
Light weight profile milled steel spool (40 spline), 3.812 bearings with 1/2" ring gear bolts, 3.812" case, 10 lbs

There is more to a spool than meets the eye. It not just a pretty part, but one of the key components that influence ring and pinion life. Our product has a reliable ratio of strength to weight. MW steel and aluminum spools are in-house produced from our exclusive forging tools that create superior grain flow for maximum strength. M/W steel spools are produced from 4140 alloys and through hardened, resulting in steel strength that is the same at the core as at the surface.

Our aluminum spools are produced from 7075 aluminum and feature the MW gold coating. The bearing diameters and ring gear register are precisely controlled utilizing CNC grinders. Custom tooling grinds all three critical diameters on the same centers. The ring gear diameter is precisely controlled, assuring the proper press fit to the ring gear. Controlling these factors while manufacturing a spool is extremely important for improving maximum gear life.

## Light Weight Spools

53127 9" Ford Light Weight Spool  
Light weight profile milled steel spool (40 spline), 3.812 bearings, 7/16" ring gear bolts, 3.812" case, 10 lbs.

53137 9" Ford Light Weight Spool  
MW 40-spline, L/W milled, 3.250" bore case, large bore wheel brgs and proper housing ends are required, weight 8.5 lbs

53138 9" Ford Light Weight Spool  
Summers type 35-spl., L/W milled, weight 9 lbs. (Dana type spline)

53147 9" Ford Light Weight Spool  
Strange type 35-spline, (Dana spline) weight 9 lbs.

## STANDARD STEEL SPOOLS

Tapered back profile For increased stiffness

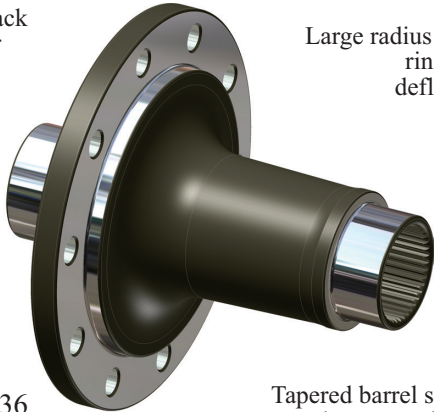

Large radius limits ring gear deflection

53136

Tapered barrel section increases rigidity

## Standard Spools

53139 9" Ford Standard Spool  
Stock type 28-spline, weight 10 lbs.

53144 9" Ford Standard Spool  
Stock type 31-spline, weight 11 lbs.

53140 9" Ford Standard Spool  
MW 35-spline for stock case, 2.893" or 3.062" bore, 11lbs.

53146 9" Ford Standard Spool  
MW 35-spline 3.25" case, weight 12 lbs.

53136 9" Ford Standard Spool  
MW 40-spline, requires 3.250" bore case and large bore wheel bearing with proper housing ends. weight 11 lbs.

## ALUMINUM SPOOLS

7075 aluminum forging

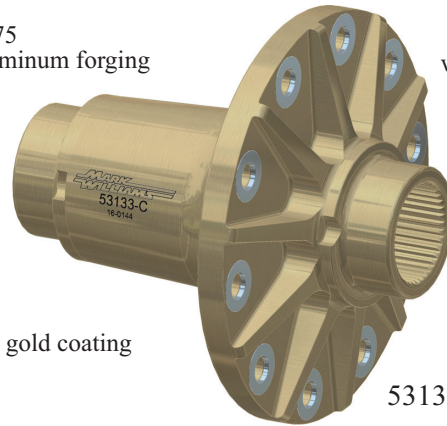

Hardened washer for ring gear bolt seat

Stiffening back ribs

MW gold coating

53133

## Aluminum Spools

53123 9" Ford Aluminum Spool  
Stock 31 spline, weight 4.9 lbs

53135 9" Ford Aluminum Spool  
Aluminum spool (35 spline), requires 3.250" bore case weight 4.9 lbs.

53133 9" Ford Aluminum Spool  
Aluminum spool (40 spline), 3.812" bearings. Requires 3.812 bore case, 57448 weight 5.5 lbs.

53149 9" Ford Aluminum Spool  
For Strange 35-spline axles.



## 9" FORD LOCKERS & POSI-TRACTION



57311



187S-35C



187S-17B



DPI-35

The 9" Ford has several ways to go when an increased traction differential is required. Mark Williams stocks several different types, the Detroit Locker, the Truetrac®, the DPI Gold Track, and the Ford Clutch Posi.

**DETROIT LOCKER™** is offered for popular 9" Ford applications (28, 31, and 35-spline). These units are designed to provide power to both wheels even in those situations where one tire loses traction. Detroit Lockers™ will also compensate for differences in wheel speed when turning corners by letting the wheel with the larger turning radius overrun and unlock from the other wheel. The 35 spline unit is popular for Pro-Street application, requiring a large axle spline and can be used for drag racing.

**CLUTCH POSI-TRACTION** are the most common and are used in the original rears. Smooth quiet action relies on spring pressure and friction in the clutch plates to increase driving traction. Quietest for street rod applications.

**TRUETRAC™ OR GOLD TRACK™** differentials do not use friction plates, but rather the wedging action of separating spiral pinion gears. This type of differential is unique in that it increases traction, but does not affect the steering, and there are no friction plates to wear. It allows normal differentiation without adverse effect on steering, or chattering when cornering. Only when there is a loss of traction, will power transfer occur. The worm drive differential offers moderate strength.

187S-13A 9" Ford 28 spline Detroit Locker™

187S-17B 9" Ford 31 spline Detroit Locker™

187S-35C 9" Ford 35 spline Locker  
*Requires 3.812" or 3.250 case. with 2.0 ID bearings*

57311 9" Ford Posi Unit (31 spline)  
*Clutch type posi-traction (Motorsports type).*

57315 9" Ford Eaton™ (35 spline)  
*Unit requires 3.812" or 3.250 case. with 2.0 ID bearings*

DPI-35 9" Ford Gold Track (35 spline)  
*Unit requires 3.812" or 3.250 case. with 2.0 ID bearings*

## 9" FORD AXLE & SPOOL PACKAGE



50100 Hi-Torque Axles



Drive Stud Kit and Washers



9" Spool 35 or 40 Spline



Wheel Bearings and Lock Rings



Bearing Retainers

The MW 9" Ford Axle/Spool Package includes a pair of custom built standard Hi-Torque axles (any length/35 or 40 spline combination), axle bearings, bearing retainer plates, standard steel spool and a complete 5/8 drive stud kit with Snap-Lock™ washers. This kit allows you to have the top of the line axle and spool kit while saving 10%.

HI-K12 Axles/Spool/Bearing/Retainer/Stud Kit  
**Call for additional savings on a lightweight components package.**

# 9" FORD COMPONENTS



This is a list of the most common replacement parts for 9" type differentials. We have many parts and components available that are not included in this listing. Give us a call for items not listed. We are never too busy to help you find the smallest part you require. We take pride in helping you get the right parts when you need them.

- 39008 MW 9" Ford Pinion Yoke  
*28-spline, 4340 steel for 1350 series U-joint.*

---

- 39011 MW 9" Ford Pinion Yoke  
*35-spline, 4340 steel for 1350 series U-joint.*

---

- 39025 9" Ford Pinion Yoke 1330 Ford Joint  
*4340 steel for Ford 1330 series joint 3-5/8 x 1-1/8" for MW support.*

---

- 5000-181 Retaining Ring For MW Ford Case

---

- 53124 9" Ford Spool Bearings, 3.812 O.D.

---

- 53141 9" Ford Spool Bearings, 2.893 O.D.

---

- 53142 9" Ford Spool Bearings, 3.062 O.D.

---

- 53143 9" Ford Spool Bearings, 3.250 O.D.

---

- 57407 Pinion Stud Kit for MW Cases 7/16"

---

- 57408 Pinion Stud Kit for MW Case 3/8"

---

- 57449 Load Bolt Kit for MW Case

---

- 57500 Heavy-Duty Adjusters, 3.062 bore

---

- 57502 Replacement Cap, 2.893" bore (ea)

---

- 57503 Replacement Cap, 3.062" bore (ea)

---

- 57510 Shim, Spool/Carrier (pr)  
*For 9" Ford Spool/Carrier in a 3-1/4" case.*

---

- 57550 Heavy-Duty Adjusters, for 3.250 bore (pr)

---

- 57560 Heavy-Duty Adjusters, for 3.812 bore (pr)

---

- 57570 Adjuster Adapter (pr)  
*To use 3.062" bearing in a 3.25" case, (best method).*

---

- 57602 Pinion Bearing Sleeve  
*For rear bearing of 57600/57620 Pinion Bearing Housing.*

---

- 57603 Solid Pre-Load Spacer  
*For 57600, 57610, 57620 and 57630 (machining required).*

---

- 57604 Shim, Yoke/Coupler  
*For use with 39008 or 40300 with stock 9" Ford pinion housing.*

- 57608 Bolt Kit, 9" Ford Pinion Support

---

- 57609 Stud Kit, 9" Ford Pinion Support  
*For stock and non MW cases.*

---

- 57900 Ring Gear Bolt Set Thin 3/4 wrench (7/16")  
*Drilled for safety wire (use ARW77 washers w/Strange spool)*

---

- 57901 Gasket, 9" Ford Thirdmember

---

- 57929 10" Gear Ford 9" Thirdmember Gasket  
*Profile to clear 10" gears EZ-Release reusable gasket.*

---

- 57902 Pinion Nut, 9" Ford (standard pinion)

---

- 57903 Pinion Nut, 9" Ford (35 spline pinion)

---

- 57904 Seal, 9" Ford Pinion (standard pinion)

---

- 57905 Seal, 9" Ford Pinion (35 spline pinion)

---

- 57906 Adjuster Locks, stock type (pr)

---

- 57907 Pinion Pilot Bearing (OE type bearing)

---

- 57908 Pilot Bearing Retainer (for stock case)

---

- 57909 Crush Sleeve (stock support)

---

- 57912 Seal, 9" Ford Pinion (40 spline pinion)  
*For 57650 or 11" pinion support Viton high temperature compound.*

---

- 57913-10 Thirdmember Stud Kit (10 ea.)  
*Thirdmember to housing attachment bolts, nuts and washers.*

---

- 57914 Pinion Pilot Bearing, .812" Long  
*For MW thru bolt cases.*

---

- 57916 9" Pinion Depth Shims .005"-.015"  
*MW alum. shims. 2ea.-.005, .007 & 1 ea.-.010, .012, .015.*

---

- 57920 Ring Gear Bolt set 9/16 wrench(1/2")  
*Drilled for safety wire (use ARW78 washers w/Strange spool)*

---

- 57940 Ring Gear Bolt set Thin 3/4 wrench(1/2")  
*Thin head 3/4" 12 point with safety wire drilled*





## 9" FORD ASSEMBLIES

The steel housing MW 9" rear end assemblies are custom produced to suit your individual application. MW's years of experience assures you that the finished product will match your exact requirements. Each assembly starts with a brand **NEW** large 9" Ford center. 3" x 1/4" wall 4130 chromoly tubes are installed and given extensive internal supports. The thirdmember mounting flange is reinforced at the attachment stud locations. MW housing ends are installed after all structural welding is completed, including any suspension mounts and or rear brace, to assure true alignment.

Thirdmembers are available from the economical nodular iron carrier to the full competition thru bolt aluminum case with 9 or 9-1/2" gears. Axle choices available range from the standard MW Hi-Torque axles to the trick Super-Light gun drilled models. Options include Carbon/Carbon disc brakes and other weight saving components. The assemblies below are a few popular combinations, call for a quote on a package that is best suited to your application.

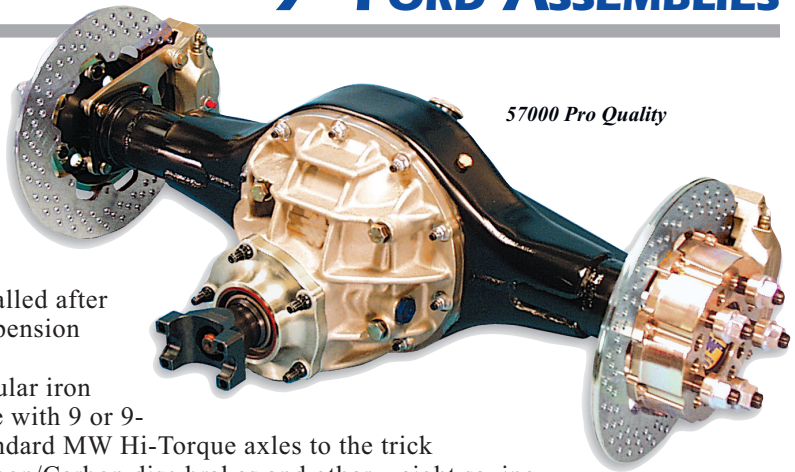

### 57000 9" Ford Complete Pro Quality Rear

*Aluminum thirdmember with thru bolt case, L.W. steel spool, Pro Gears, ball bearing pinion support and MW yoke, Super-Light gun drilled 40 spline axles with bearings and drive stud kit. Housing with 4130 tubes and brace. MW Disc brake kit with drilled steel rotors are also included.*

### 57060 9" Ford Complete Locker Rear

*Nodular iron thirdmember, 31 or 35 spline locker, 8620 gears, MW tapered bearing pinion support and MW Ford pinion yoke, standard Hi-Torque axles with bearings and 1/2" wheel studs (less brakes). 31 or 35-spline locker same price .*

### 57050 9" Ford Complete M/L Economy Rear

*MasterLine Nodular iron thirdmember, standard spool, 8620 gears, MW tapered bearing pinion support and MW Ford pinion yoke, standard MasterLine axles with bearings and 1/2" wheel studs (less brakes).*

### 57090 9" Ford Pro-Street Rear (less center)

*New 9" Ford housing with rear brace installed. Includes MW Pro Street Axles, wheel bearings, 5/8" drive stud kit and MW vented disc brakes. Specify wheel to wheel width, bolt pattern and number of splines ( same dimensions as required on axles). Complete rear less thirdmember assembly.*

## 9" FORD STEEL HOUSINGS



Mark Williams offers several steel 9" Ford housings. Housings with 3" diameter tubes are built with brand new coil spring centers, 4130 tubes with internal bracing and MW housing ends. MW also offers bolt-in housings for some popular applications that are built from stock tube housings with all required suspension mounts. All housings have a lube fill cap, drain, housing vent, and thirdmember studs installed. We can install custom brackets to any of these housings for an additional charge. If you are going to install your mount brackets in the car, we can build the housing with the ends tacked on, so it can be returned for final housing end installation. This will eliminate the welding distortion caused by the bracket installation process.

### 57120 9" Ford housing with mounts

*Fits '82-'92 Camaro/Firebird. Includes torque arm mount (no brace).*

### 57130 9" Ford housing with mounts

*Fits '78-'79 Mid size GM passenger car .*

### 57140 9" Ford housing with mounts

*Fits '79-'93 Ford Mustang with Quad shock mounts.*

### 57150 9" Ford Floater Housing

*9" center with 4130 tubes, rear brace, filler cap and bung, vent and floater spindles installed. Large tubed housing.*

### 57160 9" Ford Housing with Mounts

*Fits '64-'72 Mid size GM passenger car*

### 57200 9" Ford Large Tube Housing

*9" center with 3" 4130 tubes, filler cap and bung, vent and choice of any MW housing ends. No brace.*

### 57220 9" Ford Large Tube Housing

*9" center with 3" 4130 tubes, rear brace, filler cap and bung, vent and choice of any MW housing ends.*

**Check out the Modular 9" housing in this catalog. Many quality minded builders are opting for the advanced modular rears available with a variety of housing ends and mounting brackets. Sometimes the Modular is a better cost value than the steel housings.**

## 8.8 COMPONENTS SPOOL AND POSI-TRACTION

For drag race applications Mark Williams offers a pair of steel spools, standard steel and lightweight steel, both with MW 35 splines. These spools can be used with either MW Hi-Torque axles or MW's **MasterLine** axles. Both require the use of a MW "C" clip eliminator kit or updating to weld on housing ends. For street applications the Eaton™ 31 spline posi-traction is the good choice. With carbon fiber clutches and 400 lbs. preload this unit delivers the most torque to the rear wheels yet still gives excellent drivability.

53132 8.8" Ford 35 Spline Spool

*Must use 57900 ring gear bolt kit, 14#*

53134 8.8" Lightweight Ford Spool

*Must use 57900 ring gear bolt kit, 11#*

19588 8.8" Eaton™ Posi-Traction (31 Spline)

*31 spline with 400 lbs preload clutch, for 3.08 and up ratios*

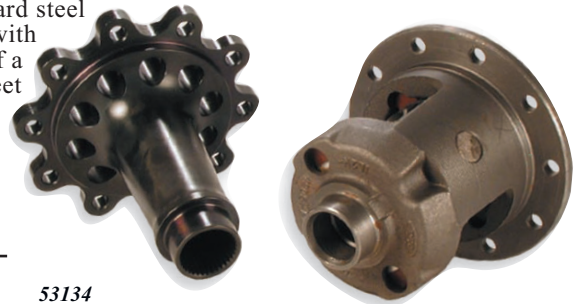

53134

19588

## 8.8 HOUSING ENDS - C-CLIP ELIMINATOR KITS



58510



59260

When preparing the 8.8" Ford rear for serious power the first modification is to eliminate the possibility of wheel loss with axle failure. The first method is to utilize a C-Clip Eliminator kit. The kit is designed to bolt on to the standard housing end with some modification. The second method is to install our replacement housing ends. Changing housing ends is the best method, especially if you need to narrow track width.

58510 8.8 Ford Housing Ends (pr)

*For 3.150" O.D. bearing with bolt kit for backing plate.*

59250 8.8 Ford C-Clip Eliminator Kit

*For MW axles with 1.564" I.D. ball bearings.*

59260 8.8 Ford Street/Strip C-Clip Eliminator. Kit

*For MW axles with 1.564" I.D. Timken® tapered roller bearings. Best kit for street applications.*

## 8.8 BILLET CAP AND YOKE

One of the most common causes of rear end failure can be traced to the stock rear end caps. To cure this problem, MW offers a billet steel replacement cap that has an increased cross section and heat treated hardware. Requires simple milling or surfacing in rod cap grinder to install.

Our 1350 series pinion yoke eliminates the circular companion flange and allows the use of a 1350 series U-Joint and high strength driveshafts as used in all other drag race cars. Driveshafts are available in mild steel, chromoly or aluminum with transmission yokes for all popular models.

The 39023 pinion yoke can be used with a 3-3/16" magnetic pickup ring.

59300 8.8" Ford Steel Main Cap (ea)

*Requires milling of cap parting line to install*

39023 MW 8.8" Ford Pinion Yoke

*For 1350 series joint for 39112 U-bolts*

39112 2nd Gen 1350 U-Bolt cap kit

*For MW 1350 Series Pinion Yokes*

TA1806 TA Cast Aluminum Cover

57140 9" Ford Mustang Bolt In Housing

*An option to consider is the 9" housing that has bolt in mounting brackets installed. see page 33 for more information*



39112

39023



59300

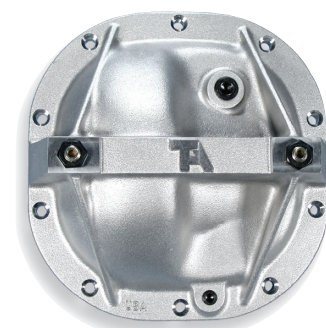

TA1806



## DANA 60 ASSEMBLIES

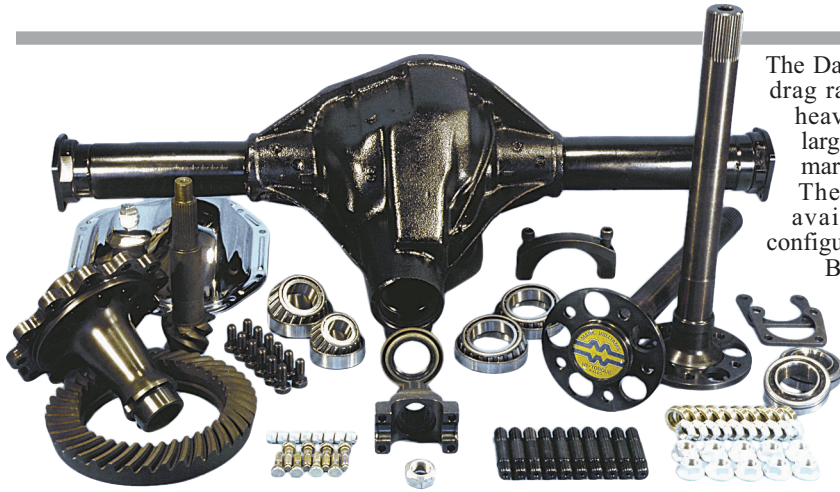

The Dana 60 series rear end has, for many years, been one of drag racing's most popular differentials, mainly due to the heavy-duty nature of the unit itself. The Dana features a large 9-3/4" diameter ring gear and the availability of after-market 8620 or 9310 alloy gears with ratios of 3.54 to 7.17! The Dana is the only passenger O.E.M. rear that was available with 35 spline axles in the original factory configuration. The main drawback to the Dana is the weight. By comparison, a complete Dana 60 is approximately 35# heavier than a 9" with a braced steel housing. A newly designed center casting has threaded adjusters for the carrier/spool bearing and pad for the Mopar type pinion snubber. The one piece center casting creates stiffness not found in thirdmember type rears. The Dana 60 offers excellent strength and reliability for the dollar. MW has a complete array of specialized components to further improve a Dana 60.

### 56002 Dana 60 Pro-Quality Rear

*Complete with Standard axles, bearings, lightweight spool (35 or 40 spline), choice of Pro-Gears, Center housing with threaded adjusters, MW pinion yoke, with 4130 steel tubes, MW housing ends, wheel bearings and 5/8" thread drive stud kit. (less brakes)*

### 56050 Dana 60 Economy Rear

*Complete with axles, bearings, standard spool (35 or 40 spline), choice of 8620 gears, MW 1350 series pinion yoke, Center housing with threaded adjusters 4130 tubes with any MW housing end and 1/2" screw in wheel studs. (less brakes)*

### 56060 Dana 60 Rear with Detroit Locker

*Complete with axles, bearings, Detroit Locker, 35 or 40 spline, choice of 8620 gears, stock pinion yoke, Center housing with threaded adjusters. 4130 tubes with any MW housing end and 1/2" screw in wheel studs. (less brakes)*

### 56100 Dana 60 Housing

*Dana 60 Housing with 3" x .25" 4130 steel tubes. Includes housing ends. New center casting width is built to customer specs. Includes a new Strange center housing with threaded adjusters*

## DANA 60 SPOOLS

MW offers three different spools for the Dana 60 rear axle. Steel spools are produced in the 35-tooth M/W version that has the 45° pressure angle spline, and the current 40-tooth 45° pressure angle spline. The aluminum spool features a 40 tooth spline and hardened washers for the bolt seat. The washers prevent deformation of the the aluminum from torquing the ring gear bolts. Another feature of the aluminum spool is a steel seat-shim retainer. This innovation keeps the preload shims centered and allows an increased radius for the bearing seat. It also allows the bearing remover to pull against the shim-retainer, preventing the destruction of the shims during setup.

### 53174 Dana 60 Aluminum Spool

*MW 40-spline, aluminum, must have 45mm bore axle bearings weight 8 lbs.*

### 53175 Dana 60 Steel Spool

*MW 35-Spline, L/W profile milled, (proper housing wheel bearings that controls axle movement is required) weight 17 lbs.*

### 53177 Dana 60 Steel Spool

*MW 40-Spline, L/W profile milled steel 15 lbs.*

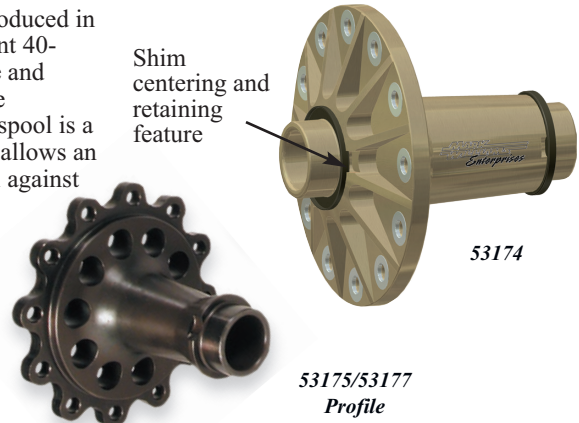

## DANA 60 LOCKER

The Dana 60 Locker features both 35 and 40 spline axle gears and will accept 4.10 to 7.17 ratio, (4 series) gears. The 40 spline locker is a new item and is available for 3.73-4.30 ratios and 4.56-7.17 ratio. MW 40 spline axles for our spool will also fit the new Locker

### 225S-23A Detroit Locker

*Dana 60 rear 35-Spline (for 4.10 to 7.17 gear)*

### 225S-40A Detroit Locker

*40 Spline for 3.73-4.10 ratio gears*

### 225S-40B Detroit Locker

*40 Spline for 4.88-7.17 ratio gears*

### TA1812 TA Dana 60 rear cover

*The TA rear cover strengthens the housing and provides support to the main caps. Steel replacement caps are recommended as the first upgrade on O.E.M. Dana type rears.*



# DANA 60 COMPONENTS

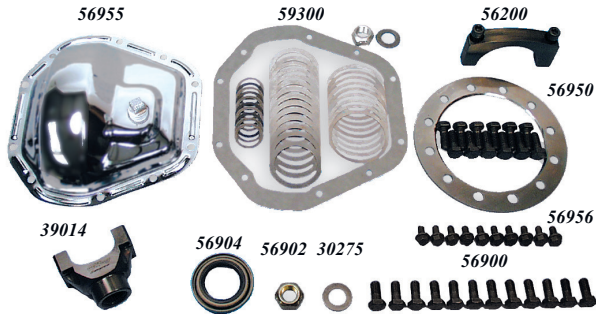

- 30275 Dana 60 Pinion Nut Washer
- 39014 MW Dana 60 Pinion Yoke  
*29-spline, 4340 steel for 1350 series U-joint*
- 53171 Spool Bearings, Dana 60
- 53172 Pinion Bearing Set, Dana 60
- 56200 Dana 60 Main Cap
- 56900 Dana 60 Ring Gear Bolt Kit
- 56901 Dana 60 Cover Gasket
- 56902 Dana 60 Pinion Nut
- 56904 Dana 60 Pinion Seal

- 56910 Dana 60 Shim Kit  
*Pinion depth and pre-load shims, spool shims, gasket, pinion nut and washer.*
- 56930 Clutch Pack  
*For Dana 60 Powr-Loc™ with 35 splines.*
- 56940 Axle Gear, (ea.)  
*For Dana 60 Powr-Loc™ with 35 splines.*
- 56950 Ring Gear Spacer  
*Dana 60 for using 4.56 to 7.17 gear on 3.54 to 4.10 carrier.*
- 56955 Dana 60 Chrome Cover
- 56956 Dana 60 Cover Bolt Kit (10 pcs)



- 56960 Powr-Lock™ Kit Dana 60 or 70  
*Clutches, axle and spider gears, spider gear pin for 35 spline Powr Lock™ posi traction. Converts 23 spline carriers to 35.*
- 83-1034 Gear Installation Kit, Dana 60  
*Shims (carrier, pinion depth, and preload), pinion nut, carrier bearings, pinion bearings, ring gear bolts, pinion nut and washer, gear marking compound and gasket.*

## DANA CENTER COVER & CAP

Replace one of the most common component failures on a Dana 60 with a MW billet steel replacement cap. The Dana 60 typically only requires one on the drivers side. Installation requires milling or rod cap grinding on the parting line of the cap.

The TA rear cover strengthens the housing and provides support to the main caps. Covers are available as an upgrade to complete rears, or separately. Steel replacement caps are recommended as the first upgrade on O.E.M. Dana type rears.

The Strange reproduced center housing that is used for the Dana 60 housing is available for special projects. It features threaded adjusters and bolt pattern for the pinion snubber like were available on the Mopar-Chrysler Hemi Cars in the seventies.

- 56200 Dana 60 Steel Main Cap w/fasteners
- 888 Labor (cap installed by MW Ent.)
- TA1812 TA Rear Cover
- 56000 Center Housing for Dana 60



## MOPAR HOUSING ENDS AND RETAINERS

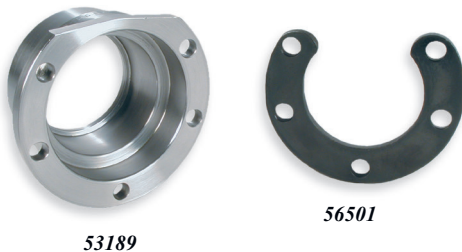

Replacement Mopar ends are produced that utilizes a larger 3.150 O.D. bearing. The 53189 end allow the advantage of the larger bearing bore, (up to 45mm) wheel bearings that increase the axle strength. If you are using aftermarket drag race disk brakes we recommend using our 58580 housing ends. It is the most straightforward end that all the dimensions are standardized. It also has the advantage that the caliper can be mounted in four different clock angels if needed.

- 53189 Mopar Housing Ends, (pr)  
*For Mopar brakes using 58503, 58504 and 58505 axle bearing.*
- 56501 Mopar Bearing Retainers, (pr)  
*For 53189 and 53188 Mopar housing ends.*



# GM 12 BOLT ASSEMBLIES

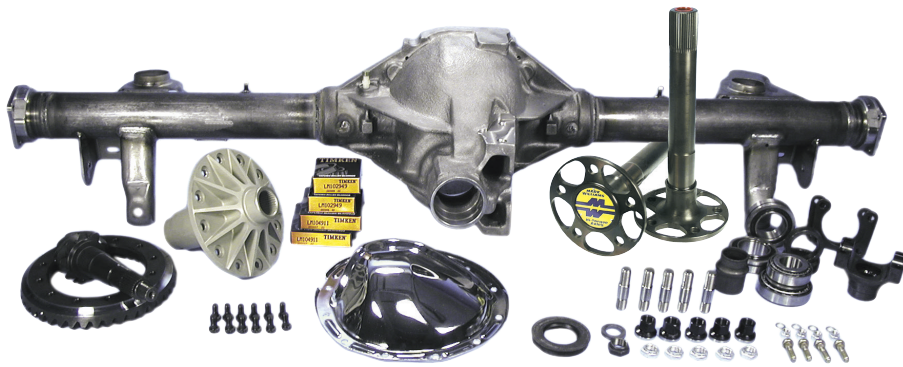

58000-RL Light Weight for GM "F" Body

suspension brackets. Three basic units are available; configurations include street/strip with Eaton™ Posi-Traction units, standard drag race with 35 spline steel spool and lightweight 35-spline aluminum spool. Bolt in models are available for ALL popular GM cars including the F- body with torque arm mounts.

M/W Disc brake can be added to any model rear end. If using an M/W Disk Brake kit, the rear will include our 58580 housing ends that take advantage of large 45mm bore bearings with inboard housing seals for a double seal. With its favorable hypoid distance and overall weight, the 12 Bolt is a good choice for applications with moderate power where friction loss and weight are important.

Additional performance improvements are available including Ring and Pinion Supra-Fin™ surface improvement finishing.



'64-'72 "A" Body



'67-69 Camaro Mono Spring Mounts

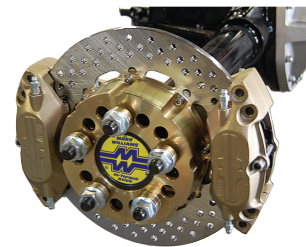

71275 Disk Brake Option

58060-S Complete GM 12 Bolt Street/Strip pkg  
With **Master**line Axles, Eaton posi, 8620 gears (no brakes)

58000-R Complete GM 12 Bolt Drag Race pkg  
With 35 Spline Hi-Torque axles, spool Pro Gears (no brakes)

58000-RL Complete GM 12 Bolt Light Wt Drag  
With MW Lightweight Aluminum Spool and Superlight Hi-Torque Gun drilled (11/16") Axles, Pro Gears, TA Cover (No Brakes).

71270 4 Caliper Disc Brake Kit  
Drilled rotors for 58580 Symmetrical housing ends, Lightened Rotors

71250 2 Caliper Disc Brake Kit  
Drilled Rotors (or Solid)

# GM 12 BOLT HOUSING



58030

MW offers DTS Express (KTRE) bare housings. Both utilize 4130 tubes and can be assembled with your choice of housing ends. The housings are produced with the stock carrier bore size 3.062" and the oversize 3.250" bore that will accommodate the MW aluminum 35 spline spool. For the builder who wants to fabricate the suspension mount in the car it makes sense to get the bare housing. We can tack weld the ends so they can be removed to install slide over brackets, and reinstall after welding.

58025 12 Bolt Bare 3.062" bore Housing  
DTS housing, 4130 tubes and any MW housing ends, 3.062" bore. Suspension mounts can be installed at an extra charge. Price will be based on the application.

58030 12 Bolt Bare 3.250" bore Housing  
DTS housing with 4130 tubes and any MW housing ends. 3.250" bore. Suspension mounts can be installed at an extra charge. Price will be based on the application.

## GM 12 BOLT SPOOLS

53130 10-Bolt 8.5" Chevrolet Spool  
*MW 35-spline 1970 or later 10 bolt, weight 14 lbs.*

53158 12-Bolt Aluminum Spool  
*MW 35 spline, housing must be bored to 3.250" Includes 58925 shim kit and 53161A bearing kit. 5.3 lbs.*

53160 12-Bolt Chevrolet Spool  
*MW 35-spline, weight 14 lbs.*

53164 12-Bolt Chevrolet Spool  
*30-spline, All 12 Bolt spools requires C-clip Elinimator kit or weld on housing ends, weight 14 lbs.*



53165 12-Bolt Chevrolet Spool  
*MW 35-spline, L/W milled, weight 11 lbs.*

53265 12-Bolt Chevrolet Spool  
*MW 35-spline, L/W milled, 11.1 lbs.*

## 12 BOLT POSI-TRACTION

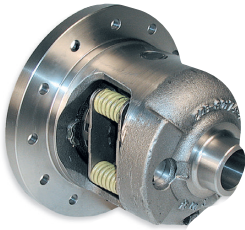

**EATON**

Eaton® Posi Performance Differentials

Mark Williams stocks Eaton™ posi-traction units for 10 and 12 Bolt GM applications. All Eaton™ units feature carbon fiber clutches.

19554 12 Bolt Eaton™ Posi-Traction (Series 3)  
*30 spline with 400 lb. clutch preload. For 3.08 to 4.10 ratios.*

19555 12 Bolt Eaton™ Posi-Traction  
*30 spline with 400 lb. clutch preload. For 4.10 and up ratios.*

19556 12 Bolt Eaton™ Truck Posi-Traction  
*30 spline with 400 lb. clutch reload. For 3.73 and up ratios.*

19557 8.5 10 Bolt Eaton™ Posi-Traction  
*28 spline with 400 lb. clutch preload. For 2.73 - 5.57 ratios.*

914A575 12 Bolt Eaton™ Truetrack  
*NEW! 33 spline For 4.10 to 6.14 ratios.*

914A576 12 Bolt Eaton™ Truetrack  
*NEW! 33 spline For 3.08 to 3.90 ratios.*

## GM HOUSING ENDS & RETAINERS

58400 G.M. Housing Ends, (pr)  
*Full size 12 Bolt, Chevrolet Impala, Biscayne and 1/2-ton pickup, for 58503, 58504 or 58505 sealed axle bearings.*

58410 Full Size GM Bearing Retainers (pr)  
*For MW 58400 Full Size GM housing ends.*

58560 G.M. Housing Ends, (pr)  
*Mid-size 10/12 Bolt, for 58506 Timken® tapered roller axle bearings and seals.*

58600 G.M. Housing Ends (pr)  
*Mid-size 10/12 Bolt, for 58503, 58504 or 58505 sealed axle bearings.*

58230 Standard GM Bearing Retainers (pr)  
*For MW 58600 10 and 12-bolt housing ends.*

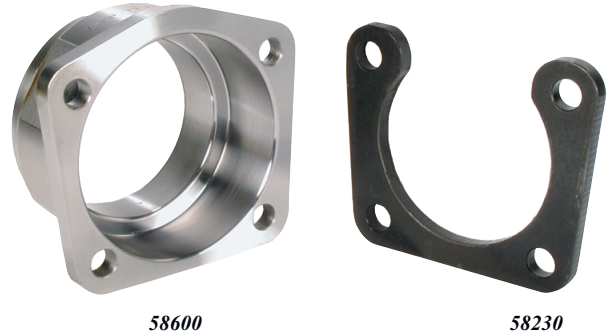

## GM C-CLIP ELIMINATOR KITS

These simple and handy kits are the perfect way to eliminate pesky Chevrolet C-clips. The kits also qualify as an accepted Safety Hub. They are easily installed on stock 10/12 Bolt axle tubes (after housing end is trimmed with a common hack saw) and accommodate large Ford style oversize bore sealed axle bearings. The press fit of the bearing and lock ring along with steel retainer plate hold the axle in place. There is a BIG DIFFERENCE in the MW C-Clip Eliminator kits when compared to our competitors. Our kits are steel, not troublesome aluminum. Our design leaves a round section of the housing, to align the bearing and carry the weight. Others rely on the bolt that is threaded into aluminum to align and carry the weight of the car. All MW C-clip kits include detailed installation instructions and mounting hardware.

58250 C-Clip Eliminator Kit  
*Small 10/12-Bolt, for MW axles with 1.625" I.D. bearings.*

58350 C-Clip Eliminator Kit  
*Full size 12-Bolt and 1/2 ton pick-up, for use with MW axles 1.625" I.D. bearing.*

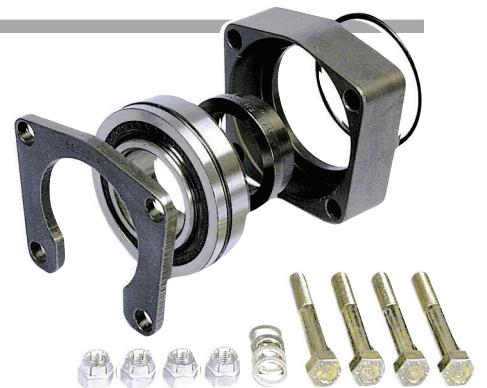

**MARK WILLIAMS Enterprises®**

# GM 12 BOLT COMPONENTS

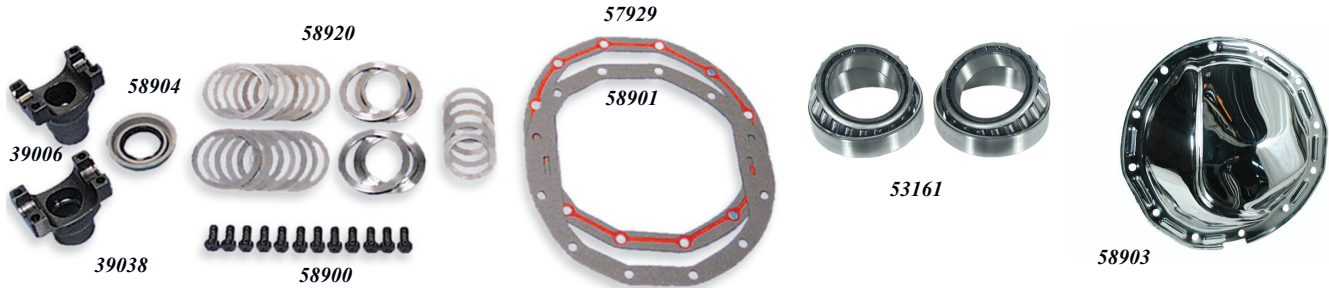

- 39006 MW 12 Bolt Pinion Yoke (3.875 long)
- 39038 MW 12 Bolt Pinion Yoke (2.875 long)
- 58903 Chrome Cover, 12 Bolt
- 53161 12 Bolt Spool Bearings (3.062 OD)
- 53161A 12 Bolt Bearings for Alum. Spool (3.250 OD)
- 53162 12 Bolt Chevrolet Pinion Bearing Set

- 58901 12 Bolt Rear Cover Gasket
- 58904 12 Bolt Chevrolet Pinion Seal
- 58920 12 Bolt Complete Shim Kit  
*Assortment of pinion depth, carrier shims.*
- 58925 12 Bolt Carrier Shim Kit (3.250" bore)  
*Special inner shim with assortment of standard carrier shims.*  
*Must be used with 53158 spool and 53161A bearing kit.*

## MW 12 BOLT IMPROVEMENTS

The MW designed pinion put has improved the OEM crimping design that destroys the pinion threads. Made from alloy steel and 100% machined with hardened washer, our design fixes the problem associated with OEM parts.

- 58918 Nut, 12 Bolt Pinion with Washer

Until now, 12 bolt rears have been forced to rely on a standard crush sleeve. The MW solid preload spacer is CNC machined from 4140 steel and heat treated. Spacers are long and must be trimmed to the required length

- 58905 12 Bolt Solid Pre Load Spacer  
*Requires machining to set the preload.*

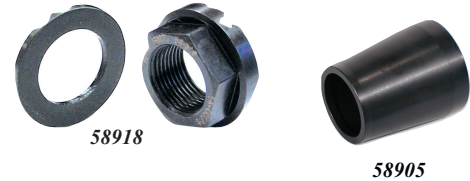

## 12 BOLT BILLET CAP & COVER

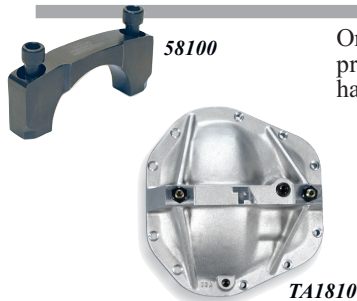

One of the most common causes of rear end failure can be traced to the stock rear end caps. To cure this problem, MW offers a billet steel replacement cap that has an increased cross section and heat treated hardware. **Simple milling required to install.**

- 58100 12 Bolt Chevrolet Steel Main Cap (ea)
- 888 Labor (cap installed by MW Ent.) (ea)
- TA1810 TA Cast Cover for 12 bolt GM car rears

## 12 BOLT AXLE & SPOOL PACKAGE



The MW 12 Bolt Axle/Spool Package includes a pair of custom built standard Hi-Torque axles (any length/spline combination), complete c-clip eliminator kit w/bearings, standard steel spool and a complete 5/8" drive stud kit. **SAVE 10%**

- HI-K14 12 Bolt Axle/Spool/C-Clip Eliminator Package

## 8-3/4 MOPAR COMPONENTS

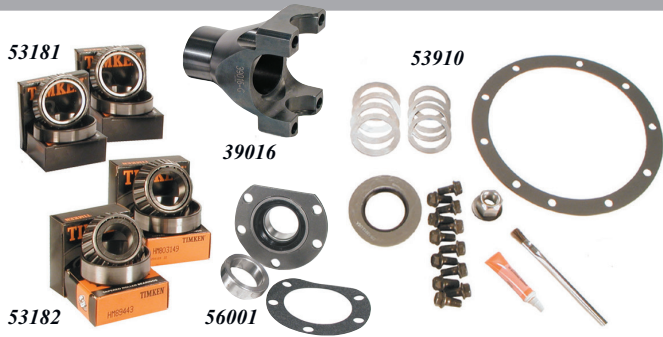

39016 MW 8-3/4" Mopar Pinion Yoke  
10-spline, 4340 steel for 1350 series U-joint

53181 8-3/4" Mopar Spool Bearings  
3.265" bore stock case (for MW spool)

53182 Pinion Bearing Set  
8-3/4" Mopar, 1-3/4" pinion diameter, 742 case

53900 8-3/4" Mopar Ring Gear Bolt Kit (L H)

53901 8-3/4" Mopar Rear Gasket

53902 8-3/4" Mopar Pinion Nut

53904 8-3/4" Mopar Pinion Seal, 1-3/4"

53905 8-3/4" Mopar Pinion Seal, 1-7/8"

53910 Pinion Shim Kit (742 Case)  
742 Case 8-3/4" Mopar, 1-3/4" pinion. Includes pinion depth and pre-load shims, pinion seal, and marking compound, pinion nut, washer.

83-5310-S Installation Kit, 8-3/4" Mopar (742 Case)  
742 case with 1-3/4" pinion. Includes pinion depth and preload shims, pinion nut and washer, pinion seal, spool bearings (2.000" ID), pinion bearings, ring gear bolts, gear marking compound, and gasket.

53920 Pinion Shim Kit (489 Case)  
489 case 8-3/4" Mopar, 1-7/8" pinion (tapered pinion). Includes pinion depth shims, crush sleeve, pinion seal, pinion nut / washer, gasket, and marking compound.

83-1037 Installation Kit, 8-3/4" Mopar (742 Case)  
742 case with 1-3/4" pinion. Includes pinion depth and preload shims, pinion nut and washer, pinion seal, stock posi carrier bearings, pinion bearings, ring gear bolts, gear marking compound, and gasket.

83-1031 Installation Kit, 8-3/4" Mopar  
489 case with 1-7/8" Pinion. Includes pinion depth shims, crush sleeve, pinion nut and washer, pinion seal, spool bearings (with 2.00" bore), pinion bearings, ring gear bolts, marking compound, gasket.

56001 Mopar Non-Adjustable Axle Bearings (pr)  
2.875" O.D., 1.562" I.D. for stock ends w/retainer

56003 Mopar Non-Adjustable Axle Bearings (pr)  
2.875" O.D., 1.562" I.D. for stock ends w/retainer, spiral lock

## 8-3/4 MOPAR SPOOLS



53179 8-3/4" Mopar Aluminum Spool  
MW 35-spline, weight 5.2 lbs.

53180 8-3/4" Mopar Spool  
MW 35-Spline, 14 Lbs.

53186 8-3/4" Mopar Spool  
Stock type 30-spline, weight 14 lbs.

53187 8-3/4" Mopar Spool  
MW 35-spline, L/W profile milled, weight 11.2 lbs.

## 8-3/4 MOPAR BILLET CAP

As with most rears, the stock caps are a weak link of the 8 3/4 Mopar. MW now offers a billet steel cap that is pre-bored and threaded. Caps are easily installed with a simple milling operation. Caps include Grade 8 hardware.

53950 8 3/4 Mopar Billet Cap(ea)

53960 Heavy Duty Adjusters (pr)  
CNC Machined Billet Steel



## 8-3/4 MOPAR AXLE & SPOOL PACKAGE

The MW 8 3/4 Mopar axle/spool package includes a pair of custom built standard Hi-Torque axles (any length/spline combination), 56003 axle bearings, standard steel spool, and a complete 5/8 drive stud kit. **SAVE 10%**

HI-K13 8-3/4 Mopar Axle Spool kit

Hi-Torque axles, spool, wheel bearings, retainers, drive stud kit

Call for additional savings on a lightweight components package



# MARK WILLIAMS Enterprises®



## '57-'64 OLDS-PONTIAC COMPONENTS



The '57-'64 Olds-Pontiac rear end is still enjoying some popularity in drag racing. These rears were fairly popular in the past and have been used in surprising numbers that is why Mark Williams Enterprises continues to manufacture and stock many of the hard to find pieces needed to assemble and strengthen this rear. .

- 39018 MW '57-'64 Olds Pinion Yoke  
*13 spline, 4340 steel for 1350 series U-joint.*

---

- 53153 Olds/Pont '57-64 Aluminum Spool  
*35 Spline M/W Spline 2.00 ID Bearing with hard bolt seat washers*

---

- 53150 Olds/Pont '57-64 Steel Spool  
*35 Spline M/W Spline 2.00 ID Bearing*

---

- 53151 '57-'64 Olds-Pontiac Spool Bearings

---

- 53152 '57-'64 Olds Rear Gasket

---

- 58500 Olds-Pontiac Housing Ends (pr)  
*For 58503, 58504 or 58505 axle bearings with seal provision*

---

- 58910 '57-'64 Olds-Pontiac Shim Kit  
*Pinion depth shims and crush preload spacer.*

---

- 83-5810 Gear Installation Kit '57-'62 Olds  
*Pinion depth shims, crush sleeve, spool & pinion bearings, seal, pinion nut and gear marking compound.*

---

- 83-5810-S Gear Installation Kit '57-'67 Olds  
*Pinion depth shims, crush sleeve, spool & pinion bearings, seal, pinion nut and gear marking compound. For MW Spool.*

## OLDS-PONTIAC BILLET CAP

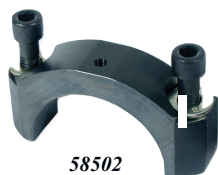

Main cap breakage is a major problem with the '57-'64 Olds. Mark Williams now offers a superior strength billet cap that is pre-bored and threaded. Caps are easily installed with a simple fly cut milling operation.

- 58502 '57-'64 Olds-Pontiac Cap (ea)

## OLDS-PONTIAC AXLE & SPOOL PACKAGE



The MW Olds-Pontiac Axle/Spool Package includes a pair of custom built standard Hi-Torque axles (any length with 35 spline spool), axle bearings, bearing retainer plates, standard steel spool and a complete 5/8 drive stud kit.

- HI-K15 Olds-Pontiac Axle spool Kit  
*Axles, spool, wheel bearings, retainers and drive stud kit.*

## SHOP LABOR OPERATIONS



- 444 Re-Drill MW Axles (only)  
*Bolt pattern change or enlarge for 5/8 drive studs. Requires heat-treating. Bearings and studs must be removed (bearing lock rings can not have been tack welded). New bearings required. Can't be performed on axles that have studs welded or holes that have been damaged*

- 555 Magnaflux and Inspect Axles (pr)  
*Bearings and studs must be removed for thorough inspection. Lock ring can not have been tack welded.*

---

- 666 Thirdmember Type Gear Set Up  
*9" Ford, 8 3/4 Mopar or Early Olds-Pontiac.*

---

- 666-11 MW 11" Gear Set Up  
*Mark Williams 11"*

---

- 777 Salisbury Type Gear Set Up  
*Dana 60, 10 or 12 bolt Chevrolet or 8.8 Ford.*

---

- 888 MW Main Cap Installation (ea)  
*Dana 60, 12 bolt Chevrolet, 9" Ford, 8-3/4" Mopar and '57-64 Olds/Pontiac.*

---

- 999 Install Housing Ends (labor only)  
*Narrow housing or re-align housing ends.*

---

- 57463 Machine Case for Internal Pump  
*Machine mounting pad for internal pump, drill fluid passage hole.*

---

- 57464 Broach Pinion for Pump Drive  
*Add 5/16" hex to 9" pinion shaft to drive internal fluid pump.*

---

- 91110 Broach Pinion for MW Pump Drive  
*Add 3/8" hex to 9" pinion shaft to drive modular fluid pump.*

### 90755 Top Alcohol 11" Modular Assembly

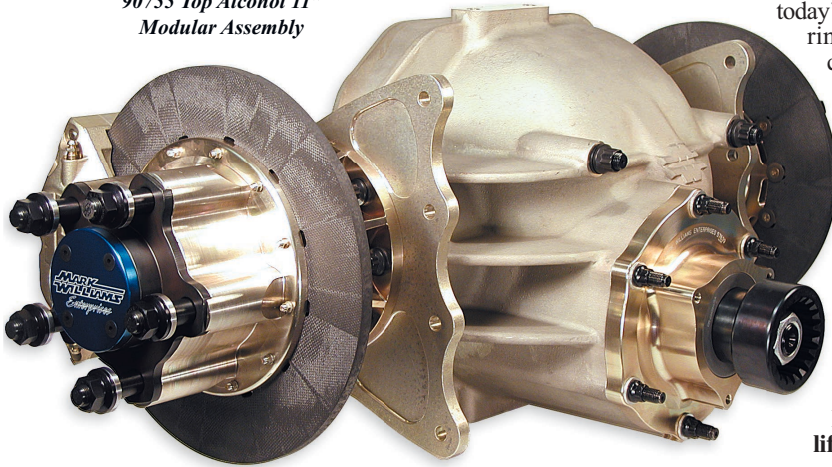

The Mark Williams 11" Modular rear end has been designed to handle the harsh treatment of today's Top Alcohol and Pro Modified cars. This assembly is based on a ring and pinion designed from a clean sheet. It is not like other competitor's efforts to make a stronger unit where their designs are based on existing housing limitations. This unit has the proper proportioning ratios of housing strength and bearing capacity that make it a superior unit.

Features include an 11" diameter ring gear and 40 spline pinion shaft. The gears are designed with a 12" pitch diameter. It could really be called a "12" Modular Rear". The gear selection are 2.91, 3.20, 3.70, 3.89, 4.10, 4.29, 4.57, 4.71 and 5.83 ratios.

We currently have the ability to produce special ratios by using our in house the gear blanks.

The special gear ratios can be delivered in approximately 8 weeks.

**Best of all we are so confident in the extended ring and pinion life we warranty the gears against breakage for 2 years.**

The housing can be used with Hi-Torque flange axles as well as the MW Floater Hubs. The unique design allows easy removal of the rear cover to inspect the ring gear, while the removable pinion support gives access to the pinion gear. With the beefy 11" gears, the use of premium materials, and features carried over from the other MW race proven modular rears, the MW 11" offers unmatched strength and reliability.

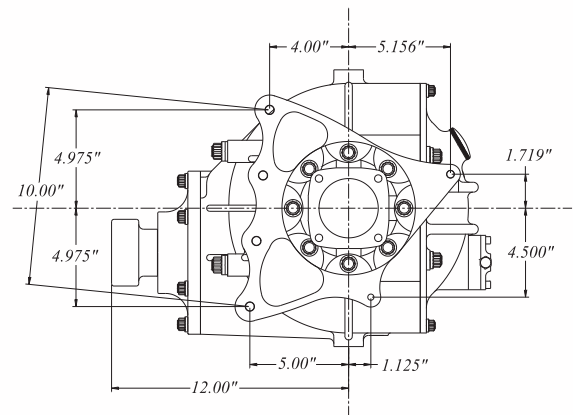
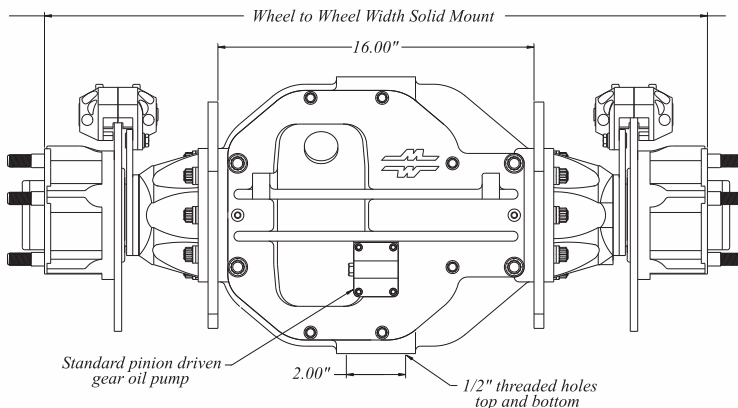

## MODULAR 11" ASSEMBLIES

### 90000 11" Modular Center Section

Fully assembled center section with MW 11" gear, 40 spline aluminum spool, ball-taper pinion support, coupler and hardware. Center section only, use this if you have an existing 9" modular rear and want to upgrade to an 11" gear.

### 90750 Complete 11" Modular Steel Brake Assembly

Complete 90000 center section with MW 11" gear, 40 spline aluminum spool, ball-taper pinion support, coupler and hardware, and end bells. MW full floater with 40 spline axles. Aluminum solid mount brackets. Includes MW 4 piston calipers and lightened steel brake rotors. 210#

### 90755 Complete 11" Modular Carbon/Carbon Assembly

Complete 90000 center section with MW 11" gear, 40 spline aluminum spool, ball-taper pinion support, coupler and hardware, and end bells. MW full floater with 40 spline axles. Aluminum solid mount brackets. Includes MW 4 piston calipers and carbon/carbon brake rotors and pads. 198#

See charts on pages 53 and 54 for solid mount widths and floater spindle combinations. Call for pricing on special widths and combinations.

## 11" PRO 4-LINK

Pro Mod and Nitro Coupe racers have an option when it comes to rear end assemblies. Ring and pinion life for the 9" Ford type rears can be a constant issue. The 11" Modular make those issues a thing of the past. The 11" Pro 4-link rear from Mark Williams represents a massive gear life improvement for high horsepower 4-link drag race cars such as Pro Mods and Nitro Coupes.

At the heart is a rugged center module that is cast from the same tough aircraft alloy used in all MW cast aluminum components. It also incorporates the thru bolt design carried with a strength enhancing cover. The bolt pattern on the mounting faces on both sides of the center is the same as MW's 9" modular rear. This means, with slight modification, all the existing MW modular hardware such as 4 link brackets, lower tie bar, end bells and floater assembly will bolt directly to this new 11" assembly, simplifying the upgrade from a MW 9" modular. The gear set features an 11" diameter (12" pitch diameter) ring gear and 40-spline pinion shaft are all produced in the USA with the most popular and special ratios available.

90775 Pro 4-Link 11" Floater Assembly

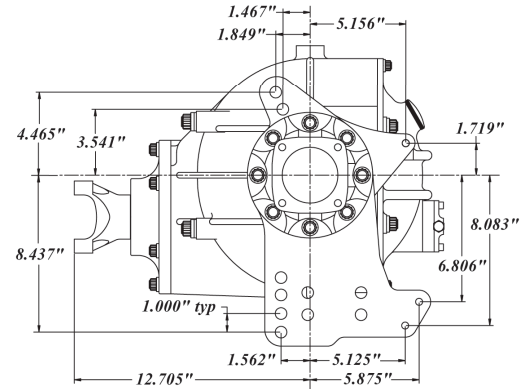
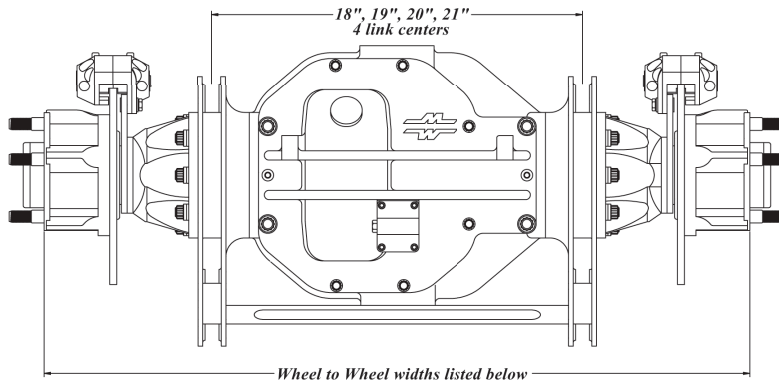
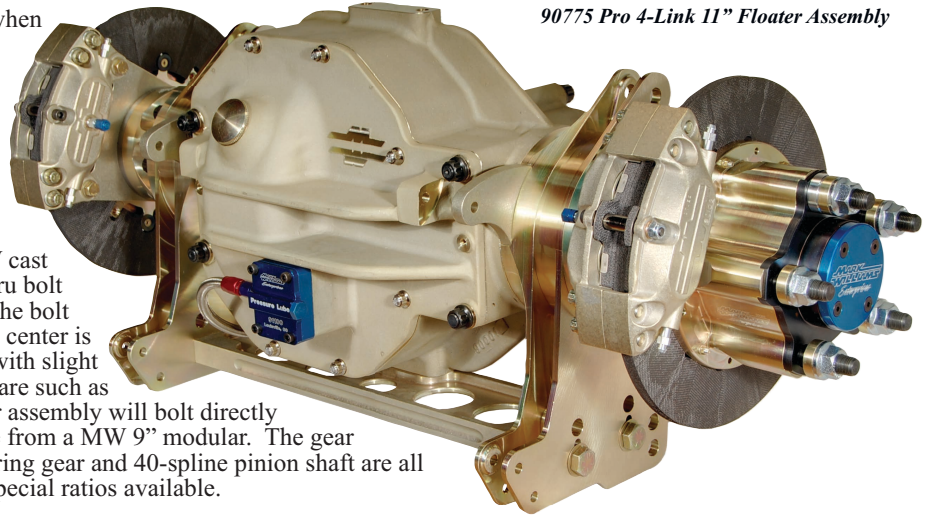

## MODULAR 11" PRO 4-LINK ASSEMBLIES



90780 Pro-Mod 4-Link carbon floater with 4130 steel brackets

90770 Complete 11" Mod 4 Link Assembly  
Complete 90020 center with MW full floating 40 spline axles, lightened steel brakes, aluminum 4-link brackets, end bells and axles. (18" centers, 35-1/2" wheel to wheel).

90775 Complete 11" Mod 4 Link Assembly  
Complete 90020 center with MW full floating 40 spline axles, carbon/carbon brakes, aluminum 4-link brackets, end bells and axles. (18" centers 35-1/2" wheel to wheel).

90780 Complete 11" Mod 4 Link Assembly  
Uses 4130 steel 4-link brackets, MW steel brake disc full floater assembly with lightened brake discs, end bells and axles. (17-1/4" centers 34-5/8" wheel to wheel).

90785 Complete 11" Mod 4-Link Assembly  
Uses 4130 Steel 4-Link brackets, full floater assembly with MW carbon/carbon disc brakes, end bells and axles. (17-1/4" centers 34-5/8" wheel to wheel).

90020 11" Modular Center Section  
Fully assembled center casting with gears, spool, pinion support, yoke and hardware. For easy swaps.

91100 Lube Pump Assembly  
Bolts to rear cover on solid or 4 link rear. Includes pump shaft and all plumbing. A must on Top Alcohol and Pro Mod cars.

See charts on pages 53 and 54 for 4-link widths and floater spindle combinations. Special narrow steel 4-link as above can be special built. Call for pricing on special widths and combinations.

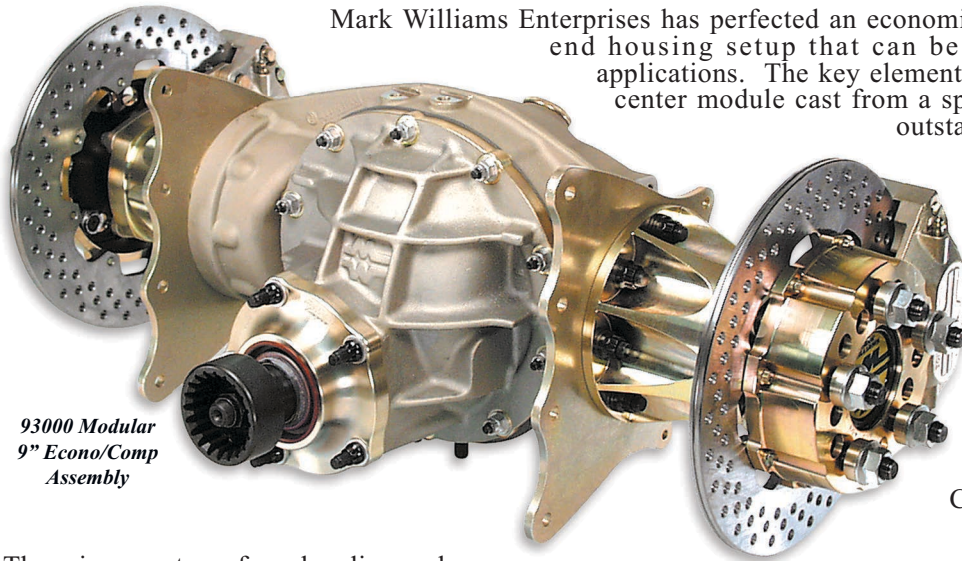

93000 Modular  
9" Econo/Comp  
Assembly

Mark Williams Enterprises has perfected an economical modular 9" Ford aluminum rear end housing setup that can be used for drag racing and street applications. The key element is the reinforced aluminum housing center module cast from a special grade aerospace alloy with an outstanding tensile strength of 60,000 psi (30% higher than 6061). The modular concept allows a variety of end bells and mounting brackets to suit your particular application. Price wise, the MW Modular stacks up favorably to the considerable re-working needed to make OEM units useable, or even the labor intensive fabricated steel housings. But the most important consideration is that the MW Modular housing is a completely CNC machined assembly and is extremely accurate.

There is zero stress from bending and welding typical to sheet metal rears. This assures you of an accurate housing that is properly aligned for optimum internal efficiency. The modular unit is also upgrade-able. If, at a later date a class change requires full floating hubs or the width needs to be changed, the appropriate end bells can be bolted on, eliminating cutting and welding. The newest addition to our modular line is the Econo/Comp 4 link housing (shown at right, recommended for LIGHT DUTY dragster and altered applications). It incorporates mild steel 4 link brackets and spacers along with a tubular lower tie bar. These new components make it easier than ever to convert a MW modular solid mount dragster housing to a 4-link set-up. This Modular rear is intended for lightweight Dragster and Altered applications that are less than 1800# and 800 HP. See part number 97780 page 47 for higher powered applications.



92400 Econo/Comp  
4-Link Housing

## 9" Econo/Comp Housings with Brackets

**92000 Econo/Comp 9" Solid Mount Housing**  
*9" center section with 5/16" mounting brackets and standard end bells, symmetrical brake mount pattern., (26" wide for 32 1/8" wheel to wheel width). Call for additional widths and applications*

**92400 Econo/Comp 9" 4 Link Housing**  
*With 3/16" mild steel 4 link brackets, tubular tie bar and standard end bells w/ symmetrical brake mount pattern, (4-link centers 17-1/4" with a 34" wheel to wheel width). Other widths available.*

## 9" Econo/Comp Complete Assemblies

**93000 Complete Econo/Comp Solid Rear**  
*Lightweight aluminum carrier, 35-spline aluminum spool, lightened standard 8620 gears, MW axles (gun-drilled), bearings, drive studs, MW disc brake kit with drilled rotors, 92000 housing. Assembled weight 133 lbs.*

**93400 Complete Econo/Comp 4 Link Rear**  
*Lightweight aluminum carrier, 35-spline aluminum spool, lightened standard 8620 gears, MW axles (gun-drilled), bearings, drive studs, MW disc brake kit with drilled rotors, 92400 housing. Assembled weight 149 lbs.*

**93050 Complete Econo/Comp Solid Rear**  
*Lightweight aluminum carrier, 35-spline aluminum spool, lightened standard 8620 gears, MW axles (gun-drilled), bearings, drive studs, MW disc brake kit with Carbon/Carbon brakes, 92000 housing. Assembled weight 121 lbs.*

**93450 Complete Econo/Comp 4 Link Rear**  
*Lightweight aluminum carrier, 35-spline aluminum spool, lightened standard 8620 gears, MW axles (gun-drilled), bearings, drive studs, MW disc brake kit with Carbon/Carbon brakes, 92400 housing. Assembled weight 137 lbs.*

## 9" FULL FLOATER

MW's full floater 9" Ford Aluminum Modular assemblies meet the requirements of classes that must have full floating hubs. Complete assemblies, including a MW aluminum thirdmember, offer reliability and provide improved performance due to precise component alignment. Being a thirdmember type rear, it's a snap to change gear ratios. With the 9", 9-1/2" and 10" ring and pinions, the Modular is suited for Top Dragster, Competition and Bracket Class applications. Thirdmembers are now available with 9-1/2" and 10" diameter ring gear (in select ratios) for added strength.

The MW floater unit incorporates sealed ball bearings (self lubricating) for minimum drag. The Floater hubs are available with a 5" or 5-1/2" bolt circle. Complete rears include full floater assemblies with a one-piece axle, (standard width only) and a large pinion thirdmember. Steel or Carbon/Carbon Disc Brakes are available for superior stopping power along with substantial weight savings.



91700 Modular 9" Full Floater Assembly

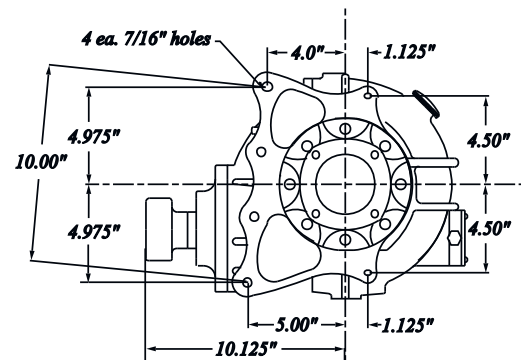
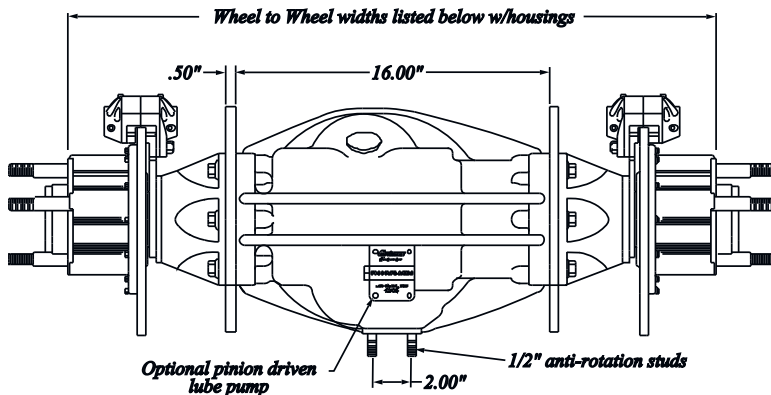

## MODULAR 9" FLOATER HOUSINGS

94700-31 Modular Floating Housing w/Spindles  
Housing with Series II spindles and 1/2" thick pocket-milled brackets (31 1/8" wheel to wheel).

94700-33 Modular Floating Housing w/Spindles  
Housing with Series II spindles and 1/2" thick pocket-milled brackets (33 1/8" wheel to wheel). 50 lbs.

94700-37 Modular Floating Housing w/Spindles  
Housing with Series II spindles and 1/2" thick pocket-milled brackets (37 1/8" wheel to wheel).

## MODULAR 9" FLOATER ASSEMBLIES

91700 Full Floating Mod. Aluminum Rear  
Floater with 1/2" mount brackets for 5" x 5 or 5 1/2" x 5 B.C, complete with Series II spindles, 57010 thirdmember (any ratio), brake assembly with lightened discs, MW calipers, one-piece axle, width 33-1/8" wheel to wheel, assembly weight 164 lbs.

91750 Full Floating Mod. Aluminum Rear  
Same as 91700 but with MW carbon/carbon brakes, assembly weight 152 lbs.

\*See pages 53 & 54 for components to make non-standard width housings.

**All Modular Housings accept thirdmembers with 10" ring gears without modifications!**

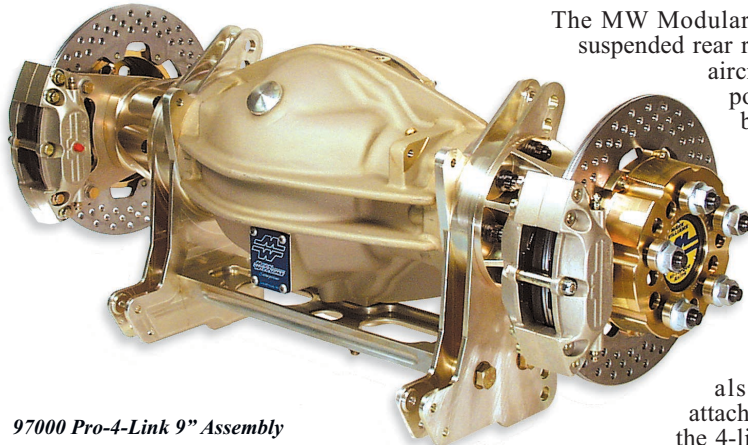

97000 Pro-4-Link 9" Assembly

The MW Modular 9" Pro 4-link housing is an outstanding choice for the suspended rear racecar. All 4 link brackets are CNC machined from 7075 aircraft alloy aluminum. The layout of the 4-link attachment points is the same as used by the leading pro stock chassis builders.

Units are available in both floater and flange type axle configurations. Unique design features include indexing lugs on each 4-link bracket that positively lock inner and outer brackets to each other and to the housing. This insures perfect alignment of all components and eliminates the possibility of the housing and thirdmember shifting between the brackets. To further strengthen the assembly, aluminum cross tie bar is used to secure the 4-link brackets to the bottom of the housing. The housing also has provisions for either upper or lower wishbone attachment along with shock and wheelie bar mounts. Holes in the 4-link brackets accommodate rod ends with 5/8" cross-holes. Standard housing has a 37" wheel-to-wheel width and 20" 4 link centers. Others widths are available (see charts on page 53 & 54).

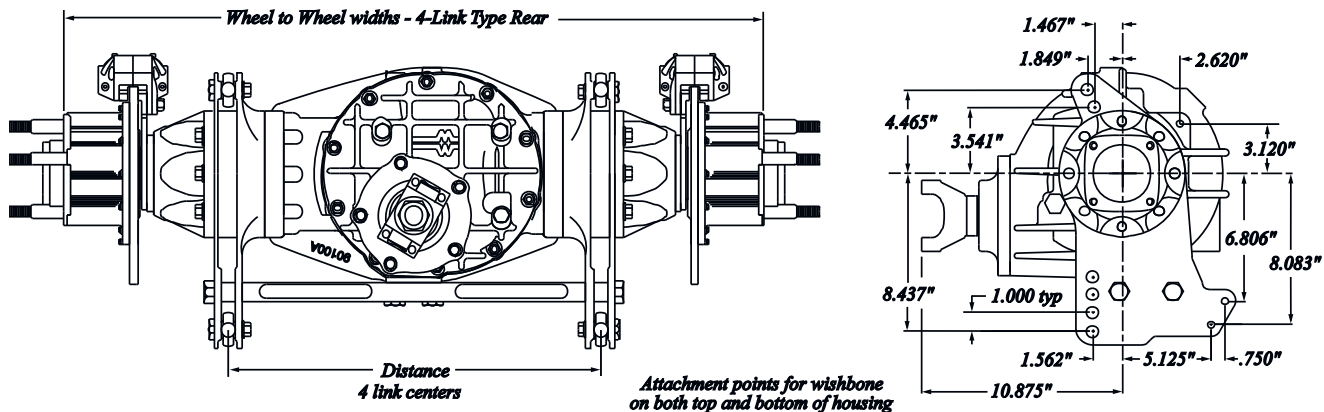

## 9" MODULAR PRO 4-LINK HOUSINGS

**96000 Mod 4-Link Flange Axle Housing**  
 Modular housing, aluminum 4-link brackets 37" wheel to wheel, 20" 4-link centers for flange type axles. See chart on pages 53-54 for other 4 link centers and wheel to wheel widths. (Other widths avail with extra charge).

**98700 Mod 4-Link Full Floater Housing**  
 Modular Floater housing, aluminum 4-link brackets, 36-5/8" wheel to wheel, 20" 4-link centers for Full Floater kit. Call for other other 4 link centers and wheel widths. (Other widths available with extra charge)

## 9" MODULAR PRO 4-LINK ASSEMBLIES

**97000 Complete Modular 4-Link Flange Rear**  
 3.812 bore H-D aluminum thirdmember with 40 spline steel spool, 9" Pro-gears, 50500 gun-drilled 40 spline flange axles, MW brakes with lightened rotors, 37" wheel to wheel and 20" 4 link centers standard. (Other widths available at extra charge) 160 Lbs.

**99700 Complete Modular 4-Link Floater Rear**  
 Large bore H-D aluminum 10" thirdmember with 40 spline steel spool, 9" Pro-gears, gun drilled 40 spline axles, MW brakes with lightened rotors, 36-5/8" wheel to wheel and 20" aluminum 4-link brackets. (Other widths available at extra charge) 185 Lbs

**97050 Complete Modular 4-Link Flange Rear**  
 Same as 97000 but with MW carbon/carbon brakes.

**99750 Complete Modular 4-Link Rear**  
 Same as 99700 but with MW carbon/carbon brakes.

# 9" PRO 4-LINK

# MW Modular

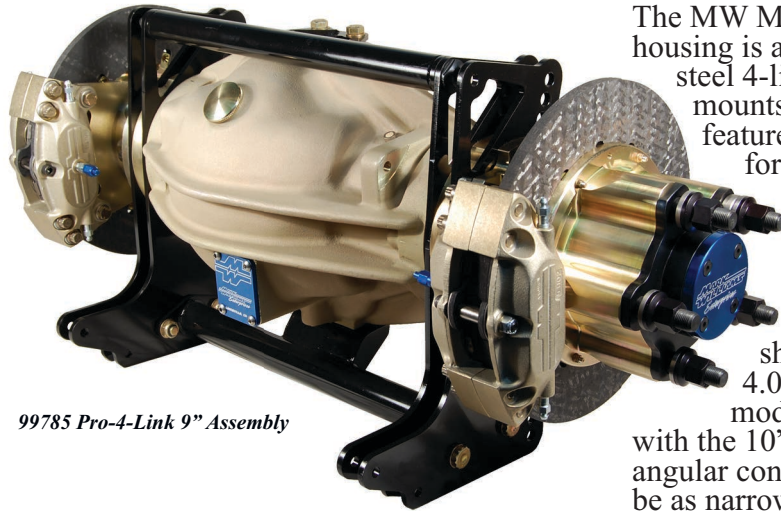

99785 Pro-4-Link 9" Assembly

The MW Modular 9" 4-link housing is available with 4130 steel 4-link suspension mounts. The steel brackets feature the key alignment lugs for extra strength. The result is a 17-1/4" 4-link center distance plus the added durability of steel brackets.

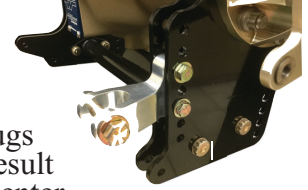

90039 Coil Over Shock Mount

Available with coil-over spring mounts, that are fixed or adjustable with aluminum shock mounting brackets. Housings accept the 4.00" Bore MW thirdmembers without modifications. The complete rears are available with the 10" ring and pinion that can include the 100% angular contact ball bearing assembly. 4-link centers can be as narrow as 16" with an optional modified (14-3/8") center housing.

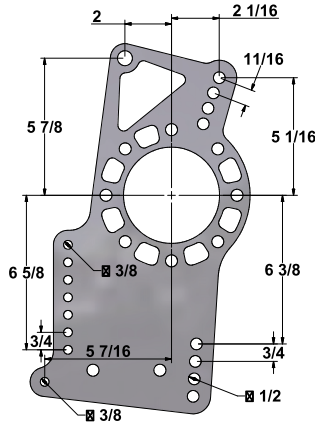

90041 ADJUSTABLE MOUNT BRACKET

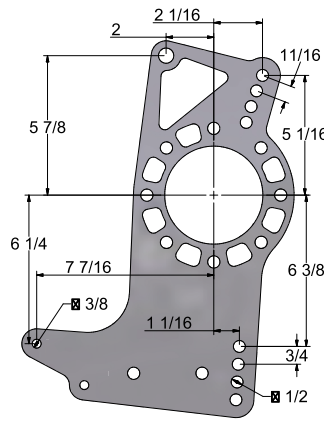

90043 FIXED MOUNT BRACKET



98780 Floater Housing 17-1/4" 4-Link centers

## 9" MODULAR PRO STEEL 4-LINK HOUSINGS

**96780 Mod Steel 4-Link Flange Axle Housing**  
Modular housing, Fixed 4130 steel brackets 34" wheel to wheel, 17-1/4" 4-link centers for flange type axles. See chart on page 53 wheel to wheel widths. (Other widths available with extra charge).

**98780 Mod Steel 4-Link Full Floater Housing**  
Modular Floater housing, 1/4" 4340 fixed 4-link brackets, 34 5/8" wheel to wheel, 17-1/4" 4-link centers for Full Floater kit. Call for other other 4 link centers and wheel widths. (Other widths available with extra charge)

## 9" MODULAR PRO STEEL 4-LINK ASSEMBLIES

**97780 Complete Steel 4-Link Flange Rear**  
4.00 bore H-D aluminum thirdmember all ball bearings with 40 spline steel spool, 10" Pro-gears, 50500 gun drilled 40 spline flange axles, MW brakes with lightened rotors, 34" wheel to wheel with 17-1/4" Steel 4 link centers standard. (Other widths available at extra charge)

**99780 Complete Modular 4-Link Floater Rear**  
Large bore 10" H-D aluminum thirdmember with 40 spline steel spool, 10" Pro-gears, gun drilled 40 spline floater axles, Steel disc brakes with lightened rotors, 34-5/8" wheel to wheel with 17-1/4" Steel 4 link centers standard. (Other widths available at extra charge)

**97785 Complete Steel 4-Link Flange Rear**  
Same as 97780 but with MW carbon/carbon brakes.

**99785 Complete Modular 4-Link Rear**  
Same as 99780 but with MW carbon/carbon brakes.

**All Modular Housings accept thirdmembers with 10" ring gears without modifications!**

**90039 Adjustable Coil Over Shock Mounts brackets and mounts**

The versatility of the MW 9" Ford aluminum modular rear is truly amazing, and we keep expanding the possible combinations. All steel tube modular rears use the same cast aluminum center, and either steel end bells or special aluminum end bells attached to 3" chromoly axle tubes.

Steel tubes allow installation of 4 link or ladder bar brackets, spring pads, or any other combination available with a traditional housing. In addition, steel tubes allow for much wider housing widths than the aluminum configurations. This opens up many new applications for the MW modular housing. Using steel end bells, 4-link housings can be built with MW laser cut 4-link brackets made from 1/4" thick steel plate. The 4-link attachment points on these brackets are similar to our aluminum brackets and accommodate 5/8" cross-hole rod end. Other mounting holes for the adjustable shock mounts and wheelie bar mounts are 3/8" diameter. 4 link centers can be as narrow as 21". To add rigidity to the 4 link mounts, a 1" X 3" steel cross tube is used to tie the 4-link brackets to the bottom of the housing.

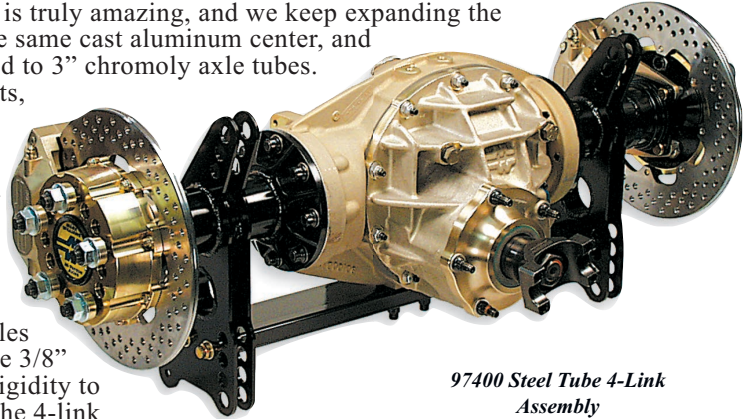

97400 Steel Tube 4-Link Assembly

## MODULAR 9" STEEL TUBE 4-LINK HOUSINGS

### 96400 Steel Tube Modular 4-Link Housing

*Any width housing, any 4-Link center to centers (min. 21"), 3" X .250" wall 4130 steel tubes with steel end bells with choice of MW housing ends.*

### 97400 Steel Tube Modular 4-Link Assembly

*Complete with Aluminum thru bolt case, 40 spline axles, lightweight steel spool, 9" Pro Gear, Steel 4-Link brackets, with tie bar, MW disc brakes, drive studs, 1350 series pinion yoke, any housing width, any width 4-Link centers (21" minimum).*

## MODULAR 9" STEEL TUBE ASSEMBLIES

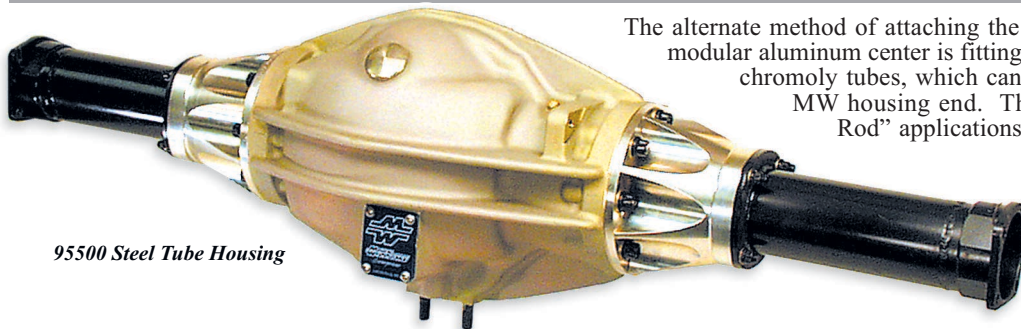

95500 Steel Tube Housing

The alternate method of attaching the steel tubes to the MW 90000-series modular aluminum center is fitting special aluminum end bells to the 3" chromoly tubes, which can be built to any length and with any MW housing end. This method is best suited for "Street Rod" applications giving the rear a more hi-tech look.

Suspension, wheelie bar, and spring mounts can be attached to the tubes at the discretion of the builder just as with a normal steel 9" housing. The most obvious benefit is the ability to use the interchangeable, easy-to-maintain 9" Ford thirdmember.

### 95000 Steel Tube Modular Street Assembly

*With aluminum end bells and 4130 tubes, your spring/suspension mounts. Any make housing ends. Pro-Street axles with Timken wheel bearings. Includes lightweight aluminum thirdmember and 31 spline posi, minimum of 38" housing width (less brakes).*

### 95500 Steel Tube Modular Housing

*3" diameter tubes with end bells for street/strip use. Spring pad or suspension mount installation is additional.*

The models listed are typical assemblies. We can build you a rear to suite your individual requirements with a different thirdmember and axle/brake combinations. We can supply a drawing of the available 4-link bolt patterns upon request. Different configurations are available. Call for a quotation on a rear with the options that meets your requirements.



## 12 BOLT ECONO/COMP

MW's 12 bolt Econo/Comp modular aluminum housing is ideal for many dragster/altered applications. The center casting is only 14" wide. When used with standard end bells the housing width is 24". This gives a wheel to wheel width of 30 1/8" allowing for the narrow rear tread width that is popular today with a number of dragster chassis builders. Other widths are available. See page 53&54 for choices. This is easily done through the use of different end bells. The 12 Bolt ring and pinion has also become popular due to its reduced internal friction. This improved efficiency frees up horsepower

and becomes more beneficial in lightweight cars or lower horsepower cars.



**93412 Econo/Comp 4-Link Housing**  
shown without axles

For suspended dragsters we offer the Econo/Comp 4 link housing (shown at left). It incorporates special steel 4 link brackets and aluminum spacers along with a tubular lower tie bar. These new components make it easier than ever to convert a MW modular solid mount dragster housing to a 4-link set-up. Another important factor is the weight of the assembly. At 122 lbs. with drilled steel rotors, the Modular 12 Bolt can easily save 10 lbs. over a 9" Ford. For the super weight conscience racer, additional weight savings of roughly 15 lbs. is possible through the use of an aluminum spool, lightened gear, and MW carbon/carbon disc brakes.

**93012 Modular 12 Bolt Econo/Comp Assembly**



## 12 BOLT ECONO/COMP ASSEMBLIES

**93012 12 Bolt Econo/Comp Assembly**  
35 spline aluminum spool, lightened Pro ring and pinion gears, MW axles (gun drilled), bearings, drive studs, MW disc brake kit with drilled rotors, 92012 solid mount housing. Assembled weight 122 lbs.

**93052 12 Bolt Pro Econo/Comp Assembly**  
Same as 93012 but with MW carbon/carbon brakes. Assembled weight 112 lbs.

**93412 12 Bolt Econo/Comp 4-Link Assembly**  
35 spline aluminum spool, lightened Richmond Pro ring and pinion gears, MW axles (gun drilled), bearings, drive studs, MW disc brake kit with drilled rotors, 4 link housing. Assembled weight 138 lbs.

**93452 12 Bolt Mod Econo/Comp Assembly**  
Same as 93412 but with MW carbon/carbon brakes. Assembled weight 128 lbs.

**91215 12 Bolt Center for IRS**  
Center with Posi or Truetrac gears with Axles for CV joints.



91215

**The 12 Bolt Modular center section is available as a ridged-mount center section featuring CV stub axles for independent rear suspension applications. Call an MW Technical representative for more information.**

With the current trend in Super Comp toward suspended dragsters and altered, the MW Modular 12 Bolt Pro 4 Link housing is the answer. The Pro 4 link housing offers many benefits over mounting a steel 12 bolt housing with suspension brackets.

MW's innovative modular design allows for a wide range of housing configurations. Housing width and 4 link centers can be adjusted through the use of different end bells and/or spacers. The housing in the assembly pictured is perfect for dragster applications with a wheel to wheel width of 33" and 4 link centers at just 16". Add to this all of the MW refinements to the 12 Bolt design increased efficiency of the 12 Bolt ring and pinion, and the lighter assembly weight vs a 9" Ford and it's easy to see that the MW Modular 12 Bolt really meets the needs of light weight race cars.

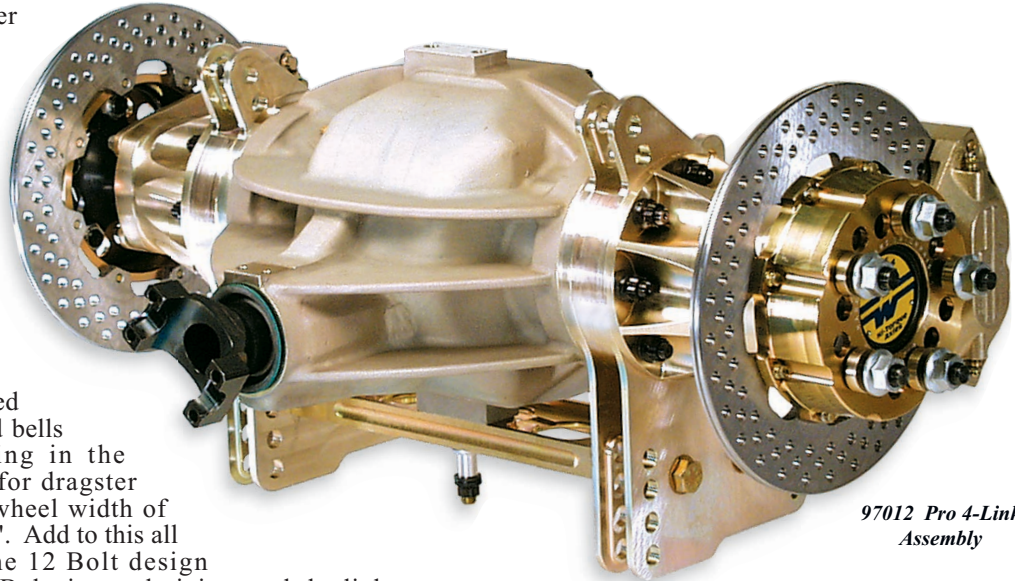

97012 Pro 4-Link Assembly

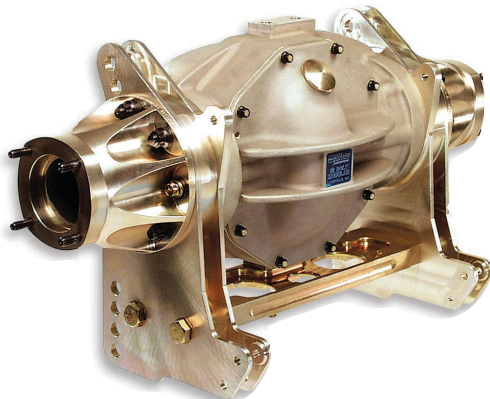

Pro 4-Link 12 Bolt Housing for fanged Axles

### DESIGN FEATURES:

INSPECTION/FILL PLUG IN COVER, A DRAIN HOLE/PLUG IN BOTTOM OF HOUSING

THREADED SPOOL-CARRIER ADJUSTMENT

COVER LOCKS ON INSIDE EDGE AND USES AN O-RING SEAL TO ELIMINATE GASKETS AND LEAKS.

THRU BOLTS INTO COVER  
CAPS SUPPORTED BY HOUSING WALL

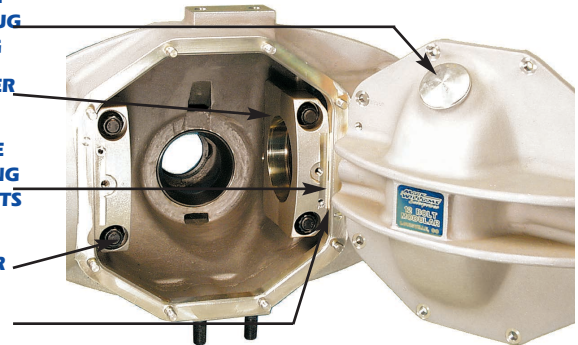

## 12 BOLT PRO 4-LINK ASSEMBLIES

### 97012 12 Bolt Pro 4-Link Assembly

With aluminum billet 4-link brackets, aluminum end bells, 35 spline aluminum spool, US Pro-gears, gun-drilled axles, MW disc brakes with drilled rotors. Standard 35" wheel to wheel. 138 lbs.

### 97512 12 Bolt Pro 4-Link Assembly

Same assembly as 97012 shown at left but equipped with a MW carbon/carbon brake kit. 128 lbs.

See pages 53 & 54 for a complete list of the housing widths and 4 link center combinations available using different end bells and/or spacers.

# 12 BOLT STEEL TUBE REARS



MW offers the Modular 12 Bolt with chromoly steel axle tubes. The steel tubes can be attached to the center with either a steel end bell or aluminum end bell. A housing built with steel end bells allows closer 4-link center distances. MW can supply the 4 link brackets (shown at right), which have 4 link layout the similar to the layout used by leading pro stock chassis builders. These brackets can be installed on the centers of your choice. They are laser cut from 1/4" thick steel plate. The hole size for the rod ends is 5/8", other mounting holes for shock and wheelie bar mounts are 3/8" diameter. The 1" X 3" tubular steel tie bar is added to stabilize the 4 link brackets.

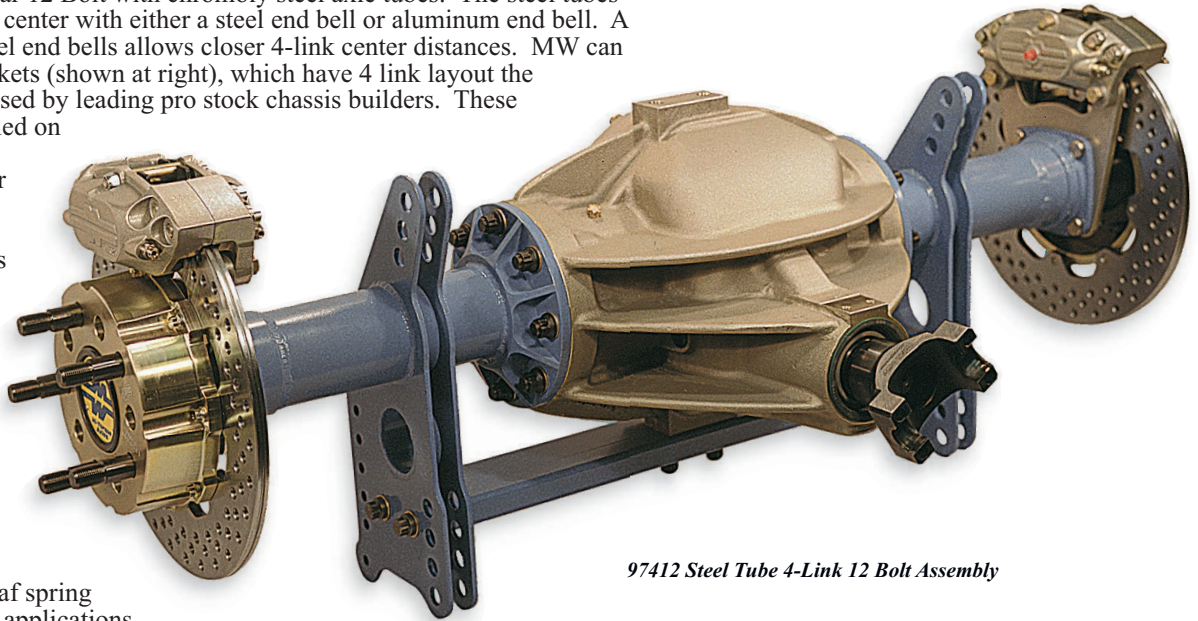

97412 Steel Tube 4-Link 12 Bolt Assembly

Aluminum end bells are available and are normally used with leaf spring applications for street applications. This method adds to the high-tech look of the housing. Spring pads can be added for bolt in units.

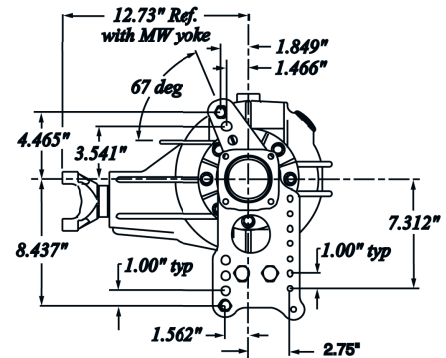
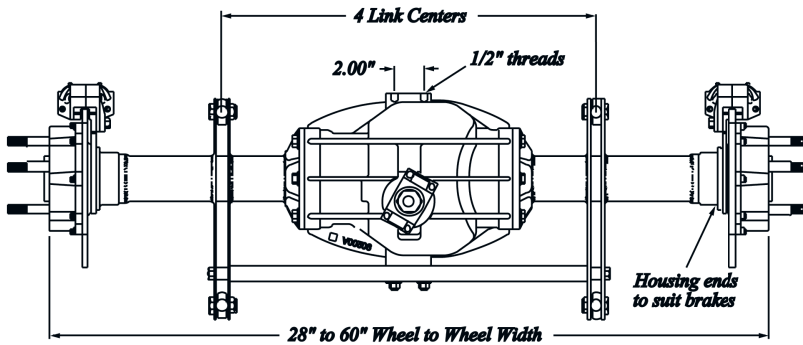

# 12 BOLT STEEL TUBE ASSEMBLIES

95412 12 Bolt Steel Tube Assembly  
 12 Bolt modular housing with **steel end bells** and housing ends to suit brakes, **MasterLine** axles 30 spline Eaton posi, 8620 street gears (3.08 - 4.88 ratios), 1350 pinion yoke, fully assembled. (less brakes)

97412 12 Bolt Steel Tube 4-Link Assembly  
 Complete with Hi-Torque 35 spline axles, lightweight steel spool, US Pro Gear, Steel 4-Link brackets, with rectangular tie bar, MW disc brakes (Drilled Rotors), drive studs, 1350 pinion yoke, any desired housing width, any width 4-Link centers .

Mark Williams can also install customers supplied ladder bar or 4 link brackets, shock mounts, wheelie bar mounts, spring pads etc. on steel tube housings. Call for pricing and more information on a housing to fit your exact needs.

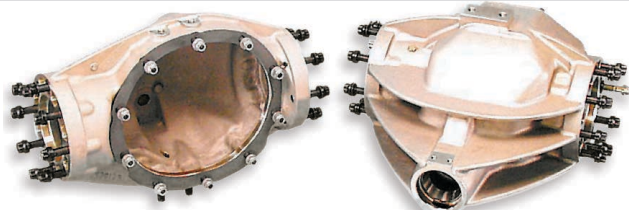

90100

90200

### 90100 9" Ford Modular Center

*Includes all studs, nuts and washers for end bells and center section, filler cap, vent and pump block off plate. Specify the thickness of the end bells or 4-link brackets to determine the proper end bell stud.*

### 90200 12 Bolt Main Modular Center

*With all studs, nuts and washers for end bells, main caps, adjusters and cast rear cover with filler cap and vent. Specify the thickness of the end bells or 4-link brackets to determine the proper end bell stud.*

## SOLID MOUNT AND 4-LINK BRACKETS

All modular brackets for solid mount applications are CNC machined from 7075-T6 billet aluminum plate. 1/2" brackets are pocket milled on both sides. Steel 4 link brackets are laser cut 1/4" 4130 and NC milled to mate to keyed spacers.

### 90012 1/2" Mount Bracket (11" Mod) (ea.)

### 90115 5/16" Mount Bracket (ea.)

### 90116 1/2" Mount Bracket (9" Mod.) (ea.)

### 90117 1/2" Mount Bracket, Blank (ea.)

*14" X 11", hole center is 3" in, semi-finished plate*

### 90041 4-Link Bracket Adjustable Height (ea)

*For 90039 shock mount, 1/4" thick 4130 material*

### 90043-I 4-Link Bracket Fixed Height (ea)

*1/4" 4130 material for 17-1/4" narrow 4-link centers*

### 90039 Adjustable Coil Over Mount Kit

*for the 90041 4-link bracket kit (pr)*

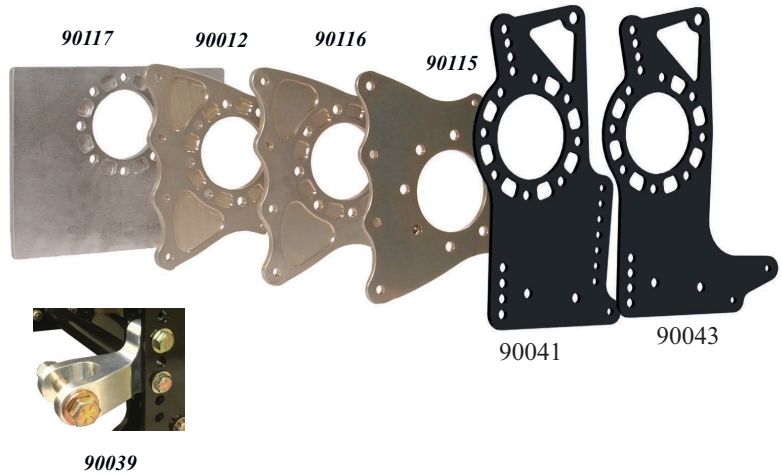

## FLUID PUMP ASSEMBLY

Mark Williams 9" and 11" Modular rears are set up to accept a fluid pump to circulate rear end lubricant from the back of the housing forward to the pinion bearings and the gear contact area to extend bearing and ring and pinion life. Pump is driven off the rear of the pinion shaft. Pump assembly includes pump shaft, required fittings, braided hose, and fasteners.

### 91100 Pressure Lubrication Pump Assembly

*Pump drive requires 3/8 hex in pinion shaft (see below).*

### 91110 Broach Hex Drive in Pinion (labor only)

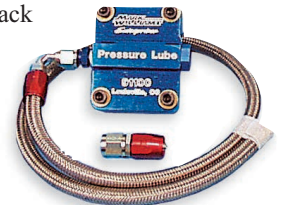

91100

## SPACERS, SEALS & TAIL LIGHT

### 90108 Rear Cover for Tail Light

*Replaces standard pump block off plate.*

### 90127 End Bell Axle Seal

*Fits into center casting before end bell is installed*

### 96020 1/2" Thick Keyed Spacer (ea.)

*Keyed spacers can be used to change 4 link centers and/or housing width on modular housings. Requires special studs.*

### 96022 1" Thick Keyed Spacer (ea.)

*Keyed spacers can be used to change 4 link centers and/or housing width on modular housings. Requires special stud*

### 96022-XXX Special Thick Outboards Spacer (ea.)



# CONFIGURATIONS



## FLANGE AXLE END BELLS

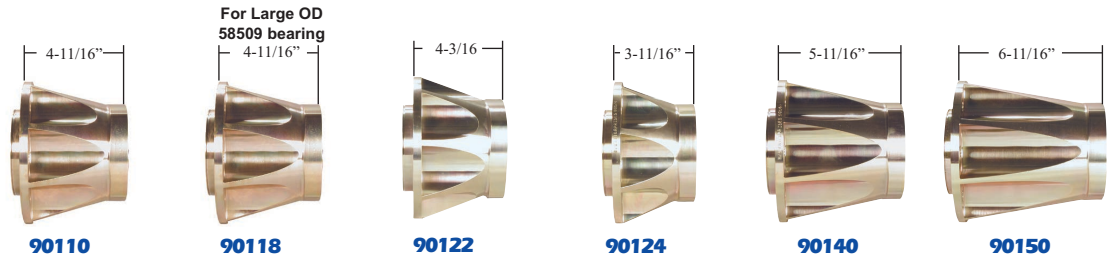

	90110	90118	90122	90124	90140	90150
<b>9" OR 11" SOLID MOUNT REAR</b>	32 1/8" WHEEL TO WHEEL	32 1/8" WHEEL TO WHEEL	31 1/8" WHEEL TO WHEEL	30 1/8" WHEEL TO WHEEL	34 1/8" WHEEL TO WHEEL	36 1/8" WHEEL TO WHEEL
<b>9" OR 11" 4 LINK 17-1/4" CENTERS</b>	34" WHEEL TO WHEEL	34" WHEEL TO WHEEL	33" WHEEL TO WHEEL	32" WHEEL TO WHEEL	36" WHEEL TO WHEEL	38" WHEEL TO WHEEL
<b>9" OR 11" 4 LINK REAR 18" CENTERS</b>	35" WHEEL TO WHEEL	35" WHEEL TO WHEEL	34" WHEEL TO WHEEL	33" WHEEL TO WHEEL	37" WHEEL TO WHEEL	39" WHEEL TO WHEEL
<b>9" OR 11" 4 LINK REAR 19" CENTERS</b>	36" WHEEL TO WHEEL	36" WHEEL TO WHEEL	35" WHEEL TO WHEEL	34" WHEEL TO WHEEL	38" WHEEL TO WHEEL	40" WHEEL TO WHEEL
<b>9" OR 11" 4 LINK REAR 20" CENTERS</b>	37" WHEEL TO WHEEL	37" WHEEL TO WHEEL	36" WHEEL TO WHEEL	35" WHEEL TO WHEEL	39" WHEEL TO WHEEL	41" WHEEL TO WHEEL
<b>9" OR 11" 4 LINK REAR 21" CENTERS</b>	38" WHEEL TO WHEEL	38" WHEEL TO WHEEL	37" WHEEL TO WHEEL	36" WHEEL TO WHEEL	40" WHEEL TO WHEEL	42" WHEEL TO WHEEL
<b>9" OR 11" 4 LINK REAR 22" CENTERS</b>	39" WHEEL TO WHEEL	39" WHEEL TO WHEEL	38" WHEEL TO WHEEL	37" WHEEL TO WHEEL	41" WHEEL TO WHEEL	43" WHEEL TO WHEEL
<b>12 BOLT SOLID MOUNT REAR</b>	30 1/8" WHEEL TO WHEEL	30 1/8" WHEEL TO WHEEL	29 1/8" WHEEL TO WHEEL	28 1/8" WHEEL TO WHEEL	32 1/8" WHEEL TO WHEEL	34 1/8" WHEEL TO WHEEL
<b>12 BOLT 4 LINK REAR 16" CENTERS</b>	33" WHEEL TO WHEEL	33" WHEEL TO WHEEL	32" WHEEL TO WHEEL	31" WHEEL TO WHEEL	35" WHEEL TO WHEEL	37" WHEEL TO WHEEL
<b>12 BOLT 4 LINK REAR 17" CENTERS</b>	34" WHEEL TO WHEEL	34" WHEEL TO WHEEL	33" WHEEL TO WHEEL	32" WHEEL TO WHEEL	36" WHEEL TO WHEEL	38" WHEEL TO WHEEL
<b>12 BOLT 4 LINK REAR 18" CENTERS</b>	35" WHEEL TO WHEEL	35" WHEEL TO WHEEL	34" WHEEL TO WHEEL	33" WHEEL TO WHEEL	37" WHEEL TO WHEEL	39" WHEEL TO WHEEL
<b>12 BOLT 4 LINK REAR 19" CENTERS</b>	36" WHEEL TO WHEEL	36" WHEEL TO WHEEL	35" WHEEL TO WHEEL	34" WHEEL TO WHEEL	38" WHEEL TO WHEEL	40" WHEEL TO WHEEL
<b>12 BOLT 4 LINK REAR 20" CENTERS</b>	37" WHEEL TO WHEEL	37" WHEEL TO WHEEL	36" WHEEL TO WHEEL	35" WHEEL TO WHEEL	39" WHEEL TO WHEEL	41" WHEEL TO WHEEL

**THE M/W MODULAR rear can be configured for flange axles or floater hubs to meet any requirement. These charts list the most popular configurations. In addition some of the modular rears used for front motor applications can use spacers between the housing and the mounting brackets to align the attachment point closer to the chassis rails.**

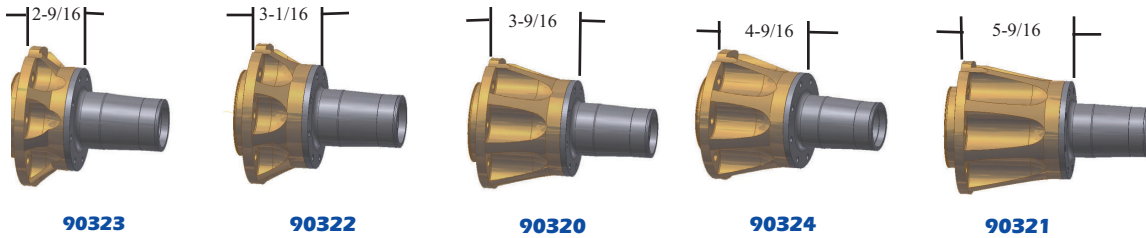

## SERIES II FLOATER END BELLS

<b>90323</b>	<b>90322</b>	<b>90320</b>	<b>90324</b>	<b>90321</b>	<b>9" or 11" SOLID MOUNT REAR</b>
<b>31-1/8 WHEEL TO WHEEL</b>	<b>32-1/8 WHEEL TO WHEEL</b>	<b>33-1/8 WHEEL TO WHEEL</b>	<b>35-1/8 WHEEL TO WHEEL</b>	<b>37-1/8 WHEEL TO WHEEL</b>	<b>9" OR 11" 4 LINK 17-1/4" CENTERS</b>
<b>32-5/8 WHEEL TO WHEEL</b>	<b>33-5/8 WHEEL TO WHEEL</b>	<b>34-5/8 WHEEL TO WHEEL</b>	<b>36-5/8 WHEEL TO WHEEL</b>	<b>38-5/8 WHEEL TO WHEEL</b>	<b>9" OR 11" 4 LINK REAR 18" CENTERS</b>
<b>33-5/8 WHEEL TO WHEEL</b>	<b>34-5/8 WHEEL TO WHEEL</b>	<b>35-5/8 WHEEL TO WHEEL</b>	<b>37-5/8 WHEEL TO WHEEL</b>	<b>39-5/8 WHEEL TO WHEEL</b>	<b>9" OR 11" 4 LINK REAR 19" CENTERS</b>
<b>34-5/8 WHEEL TO WHEEL</b>	<b>35-5/8 WHEEL TO WHEEL</b>	<b>36-5/8 WHEEL TO WHEEL</b>	<b>38-5/8 WHEEL TO WHEEL</b>	<b>40-5/8 WHEEL TO WHEEL</b>	<b>9" OR 11" 4 LINK REAR 20" CENTERS</b>
<b>35-5/8 WHEEL TO WHEEL</b>	<b>36-5/8 WHEEL TO WHEEL</b>	<b>37-5/8 WHEEL TO WHEEL</b>	<b>39-5/8 WHEEL TO WHEEL</b>	<b>41-5/8 WHEEL TO WHEEL</b>	<b>9" OR 11" 4 LINK REAR 21" CENTERS</b>
<b>36-5/8 WHEEL TO WHEEL</b>	<b>37-5/8 WHEEL TO WHEEL</b>	<b>38-5/8 WHEEL TO WHEEL</b>	<b>40-5/8 WHEEL TO WHEEL</b>	<b>42-5/8 WHEEL TO WHEEL</b>	<b>9" OR 11" 4 LINK REAR 22" CENTERS</b>
<b>37-5/8 WHEEL TO WHEEL</b>	<b>38-5/8 WHEEL TO WHEEL</b>	<b>39-5/8 WHEEL TO WHEEL</b>	<b>41-5/8 WHEEL TO WHEEL</b>	<b>43-5/8 WHEEL TO WHEEL</b>	

All dimensions are in inches. Solid mount widths are shown with 1/2" brackets.. 17-1/4" 4-Link centers is with 1/4" steel brackets. Call for special widths.

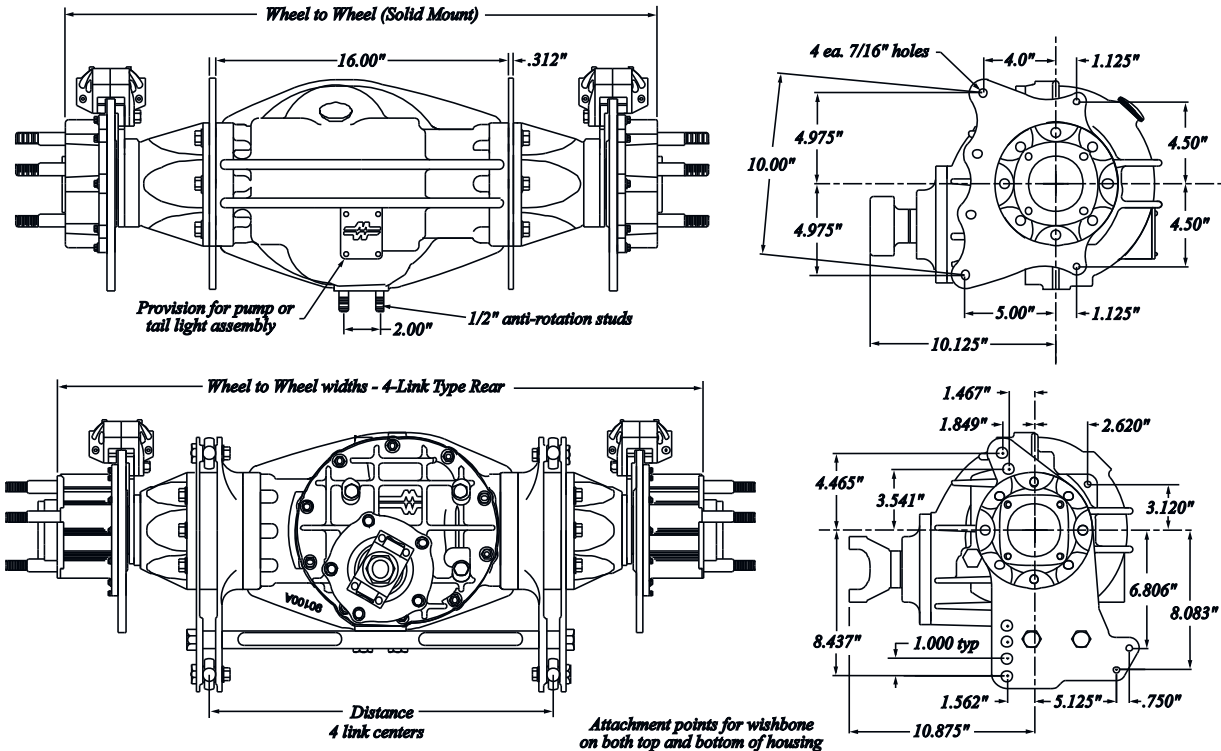

# FULL FLOATER HUB KITS

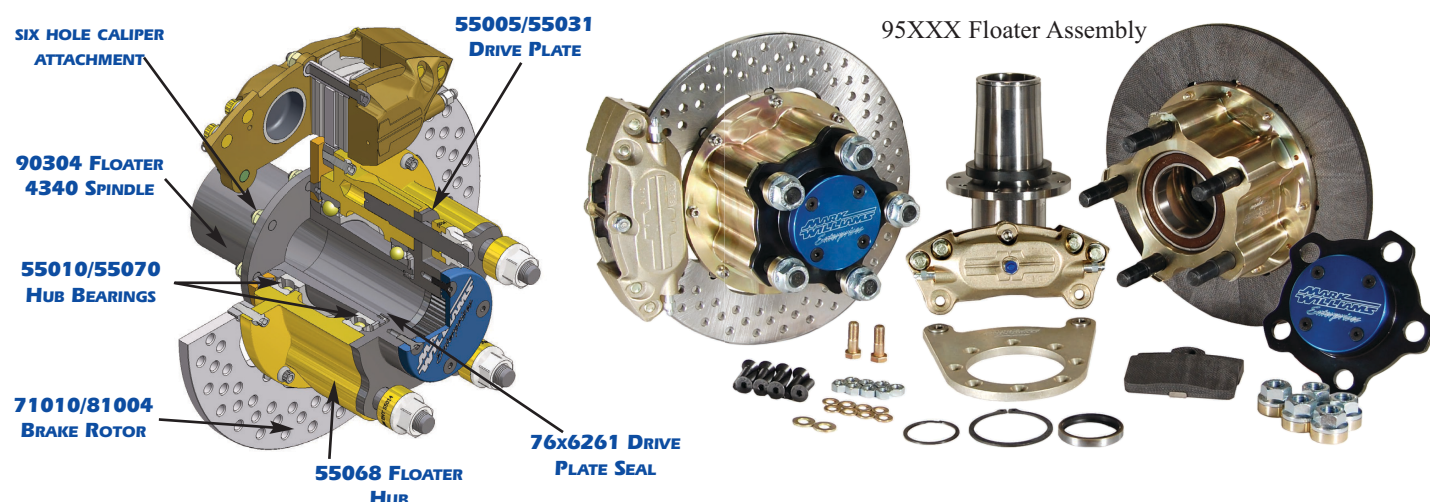

The MW Full Floater assembly is required by most sanctioning bodies for Fuel, Alcohol, and Pro Modified racecars. In the event of an axle failure, the floating hub will prevent wheel loss. An added performance advantage is that the wheel alignment is maintained under high acceleration load situations, preventing a “toe in” condition. The Series II floater assemblies feature a handful of new improvements. A larger inside bearing allows thicker spindle cross-section preventing crack propagation under severe tire-shake conditions. The forged aluminum hub has improved stud retention with deeper counter-bores and longer threads engagement. Hubs are available with either 5-1/2” or 5” X 5 hole bolt circle. Spindles are produced from forged 4340 chrome-nickel-molybdenum steel and heat-treated. Floater axles are available in the standard 4340 or 300M, solid or gun-drilled. Drive plates are 40-spline and heat-treated alloy steel or aluminum drive pates with steel spline insert as an option.

Kits are available with conventional steel rotors or carbon-carbon setups that feature our Slot-Drive™ rotor attachment technology. Upgrade options include ceramic wheel bearings and four-caliper brake kits. The floater kits are also available with long spindles, or without spindles to fit modular housings already equipped with spindles.

## STANDARD FLOATER KITS

95700 Full Floater Hub Assembly  
40 spline axles, 5 x 5” bolt pattern.

95750 Full Floater Hub Assembly  
40 spline axles, 5 x 5” bolt pattern. Less floater spindles.

95800 Full Floater Hub Assembly  
40 spline axles, 5 x 5 1/2” bolt pattern.

95850 Full Floater Hub Assembly  
40 spline axles, 5 x 5 1/2” bolt pattern. Less floater spindles.

## CARBON/CARBON FLOATER KITS

95400 Full Floater Hub Assembly  
40 spline axles, 5 x 5” bolt pattern.

95450 Full Floater Hub Assembly  
40 spline axles, 5 x 5” bolt pattern. Less floater spindles.

95555 Full Floater Hub Assembly  
40 spline axles, 5 x 5 1/2” bolt pattern.

95570 Full Floater Hub Assembly  
40 spline axles, 5 x 5 1/2” bolt pattern. Less floater spindles.

## FLOATER KIT UPGRADE OPTIONS

Dual Caliper Option w/ Steel Rotors add . . . . .P.O.A.  
Titanium Wheel Studs add . . . . .P.O.A.  
Aluminum Lug Nuts add . . . . .P.O.A.  
One Piece Floater Shaft, std length add . . . . .P.O.A.  
One Piece Floater Shaft, special length add . . . . .P.O.A.  
300M Material Axle Shafts gun drilled add . . . . .P.O.A.

Floater Axles (non-standard lengths\*) add . . . . .P.O.A.  
Gun-Drilled Floater Axles (non-standard\*) add . . . . .P.O.A.  
Long Spindle Upgrade add for pair . . . . .P.O.A.  
Ceramic Bearing upgrade . . . . .P.O.A.  
Aluminum Drive Plates upgrade for pair . . . . .P.O.A.

*\* Note: Axles are included in some floater kits. Stocked axles, (28” to 38” wheel to wheel) will be supplied gun-drilled at no additional charge. All others see pricing options.*

# FLOATER COMPONENTS

The MW unique ball bearing floater design, is easily identified by the large snap ring that retains the hub. This is a very successful drag race design and is race proven. We stock most everything you need for repair and/or replacement, or to update your current floater assembly.

55066 MW Floater Hub for Steel Rotor (ea)  
*5" bolt circle, less bearings and wheel studs Series II design.*

55067 MW Carbon/Carbon Floater Hub (ea)  
*5" bolt circle, less bearings and wheel studs Series II design.*

55068 MW Floater Hub for Steel Rotor (ea)  
*5-1/2" bolt circle, less bearings and wheel studs Series II design.*

55069 MW Carbon/Carbon Floater Hub (ea)  
*5 1/2" bolt circle, less bearings and wheel studs Series II design.*

90304 Floater Spindle, Short Series II (ea)  
*Short spindle 7-7/16" over all length 3-1/32" length from flange.*

90337 Floater Spindle, Long Series II (ea)  
*Long spindle 12-9/16" over all length, 8-1/8" length from flange.*

55005 40 Spline Drive Plate Steel 5" BC(ea)

55031 40 Spline Drive Plate, Steel 5 1/2"BC(ea)

55025 40 Spline Drive Plate Alum 5" BC (ea)

55026 40 Spline Drive Plate Alum 5-1/2" BC (ea)

55008C Floater Axle Shafts, to 20" Long (pr)

55008CG Floater Axle Shafts Gun-Drilled (pr)

55008L Floater Axle Shafts, 20" to 34" Long (pr)

The parts listed are for current kits. Most service parts for older kits are available. The current Series II Floater Hubs has a larger inside bearing. Series II spindles are required.

## BILLET WHEEL SPACERS

7304 1/4" Wheel Spacers (pr)  
*4-1/2", 4-3/4" & 5" x 5 hole patterns, for 11/16" drive studs.*

7308 1/2" Wheel Spacers (pr)  
*4-1/2", 4-3/4" & 5" x 5 hole patterns, for 11/16" drive studs.*

7314 1/4" Wheel Spacers for Floater (pr)  
*4-3/4", 5" & 5 1/2" x 5 hole patterns, for 11/16" drive studs.*

7318 1/2" Wheel Spacers for Floater (pr)  
*4-3/4", 5" & 5 1/2" x 5 hole patterns, for 11/16" drive studs.*

55008M Floater Axle Shafts, (pr)  
*300M material (custom made) up to 20".*

55008MG Floater Axle Shafts, (pr)  
*300M material 7/8" Gun drilled (custom made) up to 20".*

55010 Floater Hub Bearing, Outer (ea)  
*Double sealed ball bearing, 1 per hub.*

55070 Floater Hub Bearing, Inner (ea)  
*Series II large inner, double sealed Ball Bearing.*

55018 40 Spline Drive Plate Cover (ea)

93061 Floater Wheel Stud (ea)  
*5/8-18 thd. 4.2" over all, 2" shoulder protrudes 11/16" from drive plate.*

71010 Brake Rotor Steel(ea)  
*Slot drive mounting pattern, 11-3/4" diameter with lightening holes.*

90305 Single Caliper Mount Bracket (ea)  
*For Series II spindle, 11 3/4" rotor with a single caliper.*

95023 Dual Caliper Mount Bracket (ea)  
*For Series II spindle, 11 3/4" rotor with dual calipers.*

95029 Dual Caliper Mount Bracket (ea)  
*For Series II spindle, 11 3/8" rotor with dual calipers, for 15" wheels*

76X6261 40 Spline Drive Plate Seal (ea)

225.04.12NC Torx Screw for Cover (ea)

3100-255 Spindle Retaining Ring (ea)

MW wheel spacers are available in 1/4" and 1/2" thicknesses and are produced from billet aircraft grade aluminum (not cast). All spacers are drilled for use with 11/16" diameter drive studs. All popular wheel bolt patterns are available. The 7304 and 7308 center hole clears a 3-1/16" register. The 7314 and 7318 clears a 3-1/2" floater drive plate.



7304 7308 7314 7318

## FILLER CAPS AND BUNGS

MW offers two sizes of filler caps and weld bungs. Either suitable for many different applications, including rear end, valve cover, fuel tanks, etc. Filler cap weld bungs are available in steel or aluminum. Popular size fuel line aluminum weld bungs, drain plug w/bung and screw-in housing vents are also available.

2403 -6 Tank Weld Bung, (Aluminum), (3/8)

2404 -8 Tank Weld Bung, (Aluminum), (1/2)

5014 Rear Drain Fitting (3/8" pipe thread)

5015 Rear Filler Cap, Gold, (Alum)

5016 Rear Filler Weld Bung, (Steel)

5018 Rear Filler Weld Bung, (Aluminum)

5019 Vent Plug Rear Housing (1/4" pipe thread)

5020 Fuel Tank Weld Bung, (Aluminum)



5021 Vent Plug Rear Housing (1/8" pipe thread)

5022 -16 Fuel Line Weld Bung (Aluminum)

5030 Fuel Tank Cap (Aluminum)

5040 Fuel Tank Filler Weld Bung, (Steel)  
*Also used for a large rear axle filler/inspection port.*





# HOUSING ENDS & RETAINERS

MW manufactures a full line of weld on housing ends. All housing ends are CNC machined from **4130 heat treated forgings** and are designed to butt weld to the housing tube and match the bolt patterns of most popular brake assemblies. Most MW housing ends are 2" long and have **provisions for inboard seals** that eliminates the possible gear oil leakage through the axle bearings. This extra length also reduces distortion problems of the bearing bore from final welding.

All Pro Street Housing ends use Timken® bearings and special outboard seals. Alignment tools are available to properly install the housing ends (page 58).

**NOTE: WE RECOMMEND USING THE SYMMETRICAL 58580 OR 58599 HOUSING ENDS FOR ALL APPLICATIONS USING AFTERMARKET DISC BRAKES.**

## SYMMETRICAL

58581 Short Symmetrical Tapped (pr)  
For all 3.150 O.D. bearings. 1" long. 3/8-24 threaded holes. fig. A

58585 Pro-Street Symmetrical (pr)  
For 58506 Timken® unit bearings. fig. A

## OLDS/PONTIAC

58500 Olds/Pontiac (pr)  
For all 3.150 O.D. bearings. fig. B

58501 Olds/Pontiac Retainers (pr)

58500H Olds/Pontiac Short (pr)  
For all 3.150 O.D. bearings. 1" long. fig. B

58590 Olds/Pontiac Short Ends (pr)  
For all 3.150 O.D. bearings. 1" long with 3/8-24 threaded holes. fig. B

## CHEVROLET

58400 Full Size GM (pr)  
For all 3.150 O.D. bearings. fig. C

58600 Standard GM (pr)  
For all 3.150 O.D. bearings. fig. D

58410 Full Size GM Retainers (pr)

58560 Standard GM Pro Street (pr)  
For 58506 Timken® unit bearings. fig. D

58230 Standard GM Retainers (pr)

## FORD

57800 Small Ford (pr)  
For all 3.150 O.D. bearings. fig. E

57830 Large Ford 1/2" Holes (pr)  
For all 3.150 O.D. bearings. fig. F

57801 Small Ford Retainers (pr)

57840 Lincoln 3/8" Holes (pr)  
For all 3.150 O.D. bearings. fig. F

57802 New Style Ford Retainers (pr)

57850 Lincoln 3/8" Holes Pro Street (pr)  
For 58506 Timken® unit bearings. fig. F

57804 Large Ford Retainers (pr)

57860 New Style Ford (pr)  
For all 3.150 O.D. bearings. fig. G

57805 Lincoln Retainer (pr)

57810 Small Ford Pro Street (pr)  
For 58506 Timken® unit bearings. fig. E

58510 8.8 Ford (pr)  
For all 3.150 O.D. bearings. Includes 3/8" backing plate studs. fig. H

57820 Large Ford 1/2" Holes Pro Street  
For 58506 Timken® unit bearings. Pair fig. F

## MOPAR

53184 Mopar Long (pr)  
For 56003 or 56001 bearings. For seal. fig. I

53189 Mopar (pr)  
For all 3.150 O.D. bearings. fig. I

53188 Mopar Pro Street (pr)  
For 58506 Timken® unit bearings. fig. I

56501 Mopar Retainers (pr)

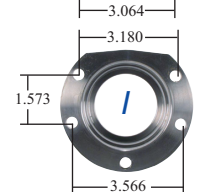
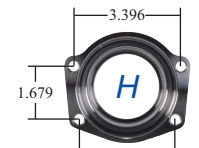
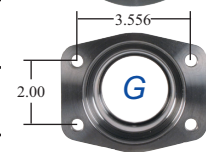
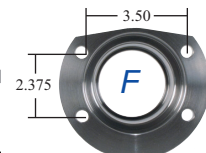
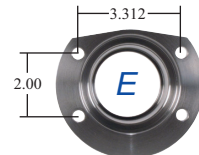
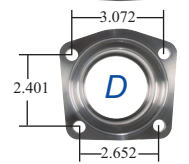
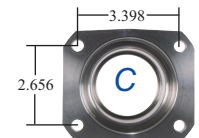
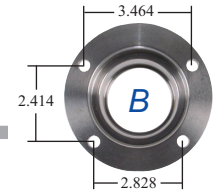
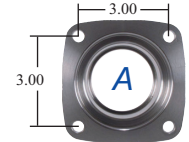
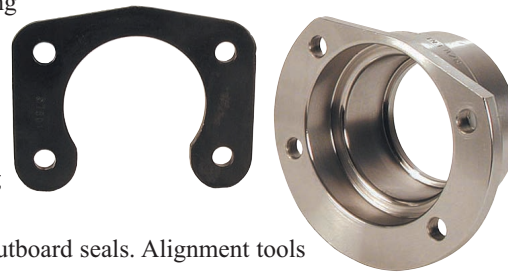

# Heavy Duty HOUSING ENDS



These ends accept a much larger, single, double row, or self aligning axle bearings that are capable of handling increased loads seen with these high horsepower cars.

The HD series and the spherical Evolution 4.1 bearings have a larger O.D. of 85mm (3.347"), which requires either modifying the existing, or purchasing new caliper mounting brackets that accept the larger diameter. The bearing used with these ends have a 45mm bore so they must be installed on axles to match. The sealing arrangement has been modified with a seal in either the caliper bracket, the housing end bore, or before the bearing in the housing end depending on the system. All ends are drilled for the 3" square symmetrical bolt pattern and require the 58572 3/8" diameter stud kit to retain the caliper brackets.

58577 Evolution 4.1 Housing Ends (pr)  
*Housing end for Evolution 4.1 system.*

58595 Ends for 85mm wide bearings w/Seal (pr)  
*For 58508 wide bearing only. 2.25" long with provision for sea*

58598 Ends for 85mm wide bearing w/o Seal (pr)  
*For 58508 sealed bearing 1.50" long no provision for inner seal*

58599 Housing Ends for 85mm Narrow bearing  
*2" long 4130 w/seal provision for 58509 bearing and 58570 bolt kit.*

## BOLT KITS & SEALS

MW stocks both 3/8" and 1/2" backing plate bolt kits as well as the stud kit required for the HD housing ends. 3/8" bolts feature quick start ends with serrations under the heads to hold them securely in the housing ends. 1/2" size are special modified fasteners. All kits also include self locking nuts. MW offers 3 different inner axle seals for all MW 2" long housing ends. These seals are designed to ride on the axle shaft just inboard of the axle bearing lock ring.

58514 Housing End Seal for 1.625 dia. Axle

58515 Housing End Seal for 1.774 dia. Axle

58516 Housing End Seal for 1.562 dia. Axle

58570 Backing Plate Bolt Kit (set of 8)  
*3/8" with nuts for MW housing ends (except large old style Ford)*



58570A Backing Plate Bolt Kit (set of 10)  
*For Mopar type ends that require 10 bolts.*

58572 Housing End Stud Kit (set of 8)  
*3/8" studs, nuts and washers for Pro Mod housing ends or MW modular end bells.*

58575 Backing Plate Bolt Kit (set of 8)  
*1/2" with nuts for large Ford ends*

## HOUSING NARROWING TOOLS

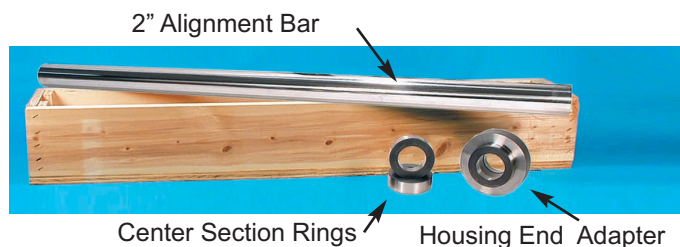

300F Housing End Alignment Ford/Fordr Kit  
300M Housing End Alignment Ford/Mopar Kit  
300S Housing End Alignment 85mm 3.349 Bearing

*The basic kit contains an alignment bar 39-1/2" long (one), a pair of differential centering rings and one housing end aligning sleeve. The kits are supplied with a choice of different bar centering rings (one pair) and housing end adapters (one). Extra rings and sleeves can be purchased to allow narrowing and truing all popular differentials.*

### Housing End adapters

302 3.150" and 2.875" Diameters  
*Large Ford Olds-Pontiac (80mm) and Mopar (73mm)*

303 3.150" and 2.834" Diameters  
*Large Ford Olds-Pontiac (80mm) and Mustang (72mm)*

310 3.349" and 3.150" Diameters  
*Symmetrical ends (85 mm) & Large Ford Olds-Pontiac (80mm)*

The M/W housing alignment tools are the most accurate way to narrow a rear end housing. It is the tool of choice for all the prominent chassis builders. The alignment bar has a large 2" diameter that is heat treated, hard chromed, and precision ground for durability and precise fit to the mating components. By utilizing a hard-chromed surface we can have a close clearance to the rings without a problem of galling to the mating parts. Alignment sleeves and center rings are produced from thru hardening steel, heat treated, honed, then outside diameters are ground on precision arbors. The quality of this tool will allow many years of accurate performance.

As an added feature, one end of the housing end tool has a 2-1/2" diameter to align the end of a 3" x 1/4 wall housing tube, for tack welding. Kits are shipped in a wooden container that is ideal for storage.

304 Floater Alignment Sleeve  
*M-W Series II floater spindles.*

### Bar Centering Rings

305 Center Section Alignment Rings  
*Dana 60, 3.812" O.D.*

306 Center Section Alignment Rings  
*Ford 9", 3.250" O.D.*

307 Center Section Alignment Rings  
*12-bolt, 8.8" Ford and Ford 9", 3.062" O.D.*

308 Center Section Alignment Rings  
*Mopar 8-3/4", 3.265" O.D.*



## FRONT DISC BRAKE KITS

The integral hub design incorporates a one piece hub/brake hat and is produced from aircraft alloy aluminum. The larger mounting diameter utilizes the Slot-Drive™ attachment system that reduces rotor distortion. The integral hub design directs the heat from the brake rotor to the wheel, the largest heat sink. The hubs are double drilled with 4-1/2" and 4-3/4" bolt patterns to fit the most popular wheels. 1/2"-20 X 2" (3" available) wheel studs are standard as are the billet aluminum dust caps with o-ring seals. The special alloy 10-1/2" diameter steel rotors are stress relieved, double disc ground in MW's facility and features cleaning grooves that act to clean the surface of the brake pads.

The heart of all Mark Williams brake kits is the MW quick-change caliper. The bridge strength of the MW caliper is superior to every other caliper on the market today due to the use of large 7/16" fasteners connecting the caliper halves and the use of a bridge bolt on the 4-piston caliper. Internal fluid porting eliminates external lines and allows calipers to be used on either side. Each kit includes Timken® tapered roller bearings, CR® inner seal, spindle nut and washer and all of the required fasteners. Timken® Hi-Temp Grease is recommended.

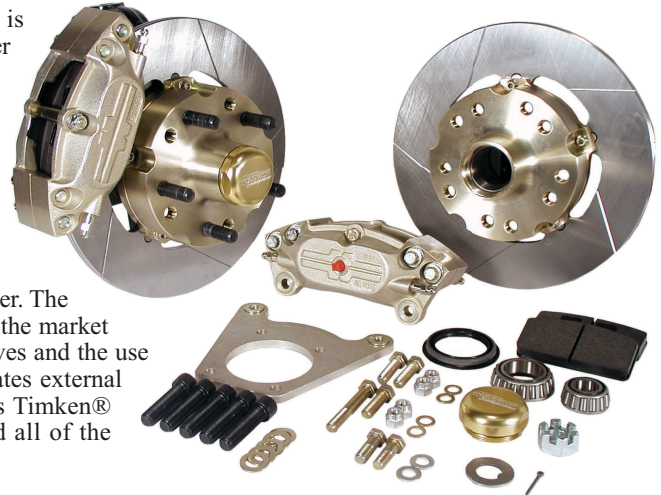

## UNIT HUB BRAKE KITS

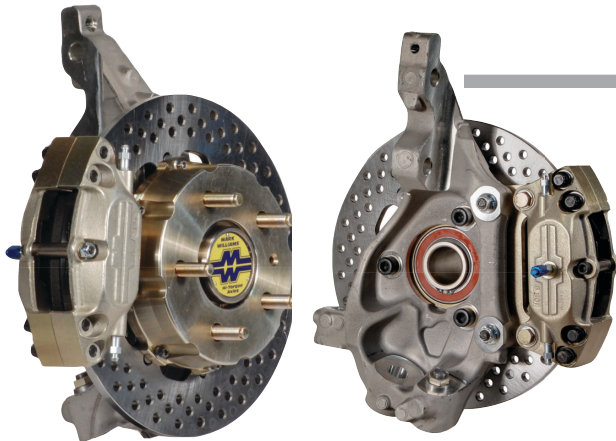

75530 Disc Kit with 75538 Hub and Spindle Modifications

Mark Williams Enterprises now has a high quality front brake kit available for the Generation 5 GM cars that utilize a Unit Front Hub design. Kit features Slot-Drive™ disc attachment system that is produced from rust resistant stainless steel. This design allows components to thermally expand and contract without creating warping stress common in other systems. This precision kit features heat-treated large diameter steel alloy rotors. The lightening holes reduce rotating weight and create a fresh friction surface on the brake pads ensuring optimal stopping surfaces. All brackets are made from 7075 grade aircraft aluminum alloy and feature a gold finish. The MW brake kit maintains the original track width to preserve the original steering geometry. Our kit features four piston MW calipers with internal porting.

75530 GM Gen 5 Disc brake kit

*Requires spindle modifications for caliper and rotor hat clearance. See service Bulletin # SB0090 for modifications required.*

75530-MOD Modify Customers Spindles (pr)

## SUPER LIGHT GEN 5 CAMARO HUB

For the COPO cars. This is a direct replacement for the heavy and high drag OEM unit bearing hub. Designed for maximum weight savings and reduction of drag, this unit features triple low drag bearings, an aircraft aluminum housing, and a lightened, heat treated aircraft alloy hub. The rotating torque is 75% less than the OEM assemblies. Our alloy steel hub is nickel plated for rust prevention and features an extensive internal tulip profile for maximum weight reduction.

A weight savings of 6 pounds per vehicle is obtained.

75538 Gen 5 GM Hub Assembly

*Choice of 1/2-20 x 2" or 3" long wheel studs*

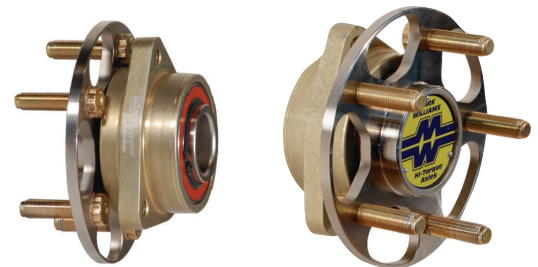

## GENERAL MOTORS INTEGRAL HUB KITS

75150 Early Camaro/Chevelle 4 Piston Kit  
*'67-'69 Camaro/Firebird '67-'72 Chevelle '68-'74 Nova (all drum spindles).*

75200 Late GM "F" Body 2 Piston Kit  
*'93-'00 Camaro/Firebird*

75250 Late GM "F" Body 4 Piston Kit  
*'93-'00 Camaro/Firebird*

75840 Camaro/Chevelle 4 Piston Kit  
*'70-'76 Camaro/Firebird '73-'76 Chevelle '75-'76 Nova Spindle*

75850 3rd Generation Camaro 4 Piston Kit  
*'82-'92 Camaro/Firebird*

75860 Corvette 4 Piston Kit  
*'84 Corvette w/ aluminum Spindles*

75870 Corvette 4 Piston Kit  
*'69-'82 Corvette '68-'72 Chevy Pass. w/disc brakes*

75950 GM "G" Body/S-10 4 Piston Kit  
*'94-'00 Chevy S-10 '79-'87 Monte Carlo and Malibu '79-'87 Grand Prix*

## FORD KITS

75350 Late Pinto/Mustang II 4 Piston Kit  
*'74-'78 Mustang II '74-'80 Pinto*

75450 Early Pinto 4 Piston Kit  
*'71-'72 Pinto (drum brakes)*

75460 Mustang 4 Piston Kit  
*'70 Mustang/Falcon/Fairlane ,71-'74 Comet (drums)*

75650 Early Mustang 4 Piston Kit  
*'67-'69 Mustang '66-'69 Comet (drum)*

75655 '64 Fairlane T/B 4 Piston Kit  
*'64-'65 Fairlane*

75750 Late Mustang 4 Piston Kit\*  
*'79 Mustang 4&6 cyl '80 All '81 some*

75760 '78-81 Mustang 4 Piston Kit  
*'79-'81 Mustang 4 & 6 cylinder*

75770 '87-'92 Mustang 4 Piston Kit  
*8 cylinder strut*

75000-S Special Application Brake kits  
*We can produce some special kits Priced On Application (P.O.A.)*

## MOPAR KITS

75500 "A" Body 4 Piston Kit

75540 Challenger 4 Piston Kit  
*2009 Challenger Unit Hub type Kit*

75550 "A" Body 4 Piston Kit

75570 "E" Body 4 Piston Kit

**Note: To assure the proper fit we require the spindles for Mopar Kits to be sent for variation and factory installation. We have found there are so many variations, this method is the only way we can assure a proper installation.**

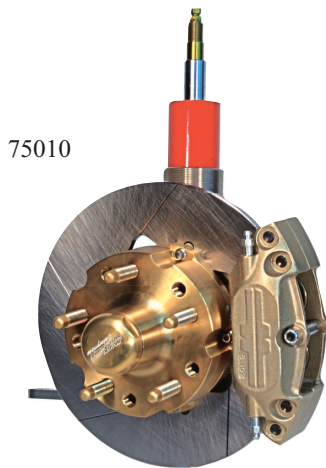

75010

## RACING STRUT INTEGRAL HUB KITS

MW Brake kit for Drag Race Struts that utilize bolt on wheels. Integral hub design with 4-3/4" and 4-1/2" x 5 hole bolt pattern, 1/2-20 threads. Steel 10-1/2" diameter steel disc with M/W Calipers.

75000 Strange Sportsman Strut 2 Piston Kit

75010 Santhuff Strut 4 Piston Kit

75030 Bickel Super Stock Strut 4 Piston Kit

75040 Bickel Strut 2 Piston Kit

75050 Strange Sportsman Strut 4 Piston Kit

75070 Art Morrison Strut 4 Piston Kit



73300

## SPINDLE MOUNT KITS

MW's floating brake rotor solves the installation problems associated with fixed rotor kits. Mark Williams now offers several kits that are direct bolt-on to aftermarket style front struts. Also included are kits designed for MW Anglia/P&S style front spindles, plus the Strange adjustable Dragster/FC spindle.

All kits feature designs that use a solid mounted billet aluminum two piston caliper, billet aluminum rotor adapter, and unique, patented, USP 6,988,598 B2, floating brake rotor (available in steel or carbon fiber). With this design, run-out on the back of the wheel is not critical. Please note that your MW dragster spindles must be sent to the factory for bracket installation or are available new with the mounting tabs installed.

73000 Spindle Mount Kit

*MW front spindles. This kit requires spindles be sent to factory for bracket installation, part #31250*

73100 Carbon Spindle Mount Kit

*MW front spindles with carbon rotors and pads. This kit requires spindle bracket installation, part # 31250*

73200 Strange Spindle Mount Kit

*Strange aluminum funny car spindles. With steel rotors.*

73300 Lamb/JBRC Strut Kit

*Lamb or JBRC front struts with steel rotors.*

73350 Santhuff Strut Kit

*Santhuff struts. With steel rotors.*

73400 Carbon Kit Lamb/JBRC Strut Kit

*Lamb or JBRC struts with carbon rotors and pads.*

73450 Carbon Kit Santhuff Strut

*Santhuff struts. With carbon rotors and pads.*

73500 Carbon Kit Strange F/C Spindle

*Strange Adjustable F/C Spindles with carbon rotors and pads*

31250 Install Tabs On MW Spindle

*Labor to install caliper mounting tabs on MW spindles*

**MARK WILLIAMS Enterprises®**

## REAR DISC BRAKE KITS

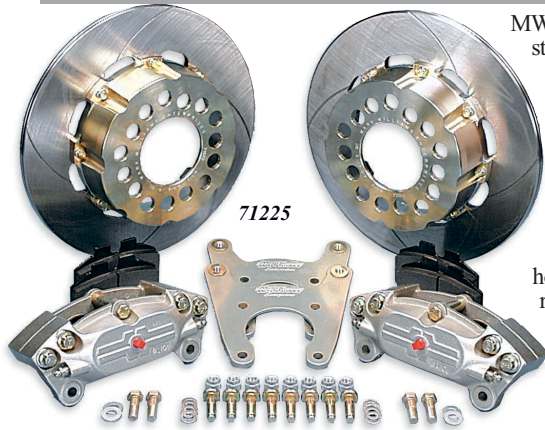

71225

MW calipers are exceptionally strong, compact, with superior bridge strength over similar products. The material used in MW calipers is stronger than common 6061 aluminum billet calipers. All MW calipers use four 7/16" diameter body fasteners plus a 5/16" diameter bridge bolt in an effort to maximize the calipers rigidity. MW calipers utilize a 3/8" hex bleeder screws in each end, no right and left hand calipers. Internal fluid passages eliminating external damage prone lines.

Caliper mounts are billet 7075-T6 aluminum, Adapter rotor "hats" are proprietary alloy aluminum, triple drilled with 4-1/2", 4-3/4 and 5" X 5 holes drilled to accept 5/8" (11/16" shoulder) drive studs. The brake rotors are abrasive resistant steel that is double disc ground to be flat and parallel. All the required mounting hardware and MW calipers with linings are included. The Slot Drive™ rotor attachment system is a major improvement for prolonging brake rotor life. Disc cupping is eliminated with this exclusive attachment method.



81100



Slot-Drive™ System

## FORD BRAKE KITS

71525 Solid Steel Disc Brake Kit  
*Large Ford housing ends with 1/2" bolts.*

71550 Drilled Steel Disc Brake Kit  
*Large Ford housing ends with 1/2" bolts.*

71825 Solid Steel Disc Brake Kit  
*Small Ford housing ends with 3/8" bolts.*

71850 Drilled Steel Disc Brake Kit  
*Small Ford housing ends with 3/8" bolts.*

71325 Solid Steel Disc Brake Kit  
*New Style Ford Ends with 3/8" bolts.*

71350 Drilled Steel Disc Brake Kit  
*New Style Ford Ends with 3/8" bolts.*

## CHEVROLET KITS

71725 Solid Steel Disc Brake Kit  
*GM mid-size MW 58600 housing ends.*

71750 Drilled Steel Disc Brake Kit  
*GM mid-size MW 58600 housing ends.*

71925 Solid Steel Disc Brake Kit  
*Stock housing ends with MW "C" clip eliminator kit.*

71950 Drilled Steel Disc Brake Kit  
*Stock housing ends with MW "C" clip eliminator kit.*

## OLDS/PONTIAC KITS

71125 Solid Steel Disc Brake Kit  
*Olds-Pontiac housing ends.*

71150 Drilled Steel Disc Brake Kit  
*Olds-Pontiac housing ends.*

## MOPAR KITS

71625 Solid Steel Disc Brake Kit  
*Mopar housing ends. Caliper mounts require modifications when using MW 53189 ends.*

71650 Drilled Steel Disc Brake Kit  
*Mopar housing ends. Caliper mounts require modifications when using MW 53189 ends.*

## SYMMETRICAL END KITS

71225 Solid Steel Disc Brake Kit  
*MW 58580 Symmetrical housing ends, 3.150 bearing.*

71250 Drilled Steel Disc Brake Kit  
*MW 58580 Symmetrical housing ends, 3.150 bearing.*

71230 Solid Steel Disc Brake Kit  
*Heavy Duty Symmetrical housing ends, with 3.347" OD bearing.*

71280 Drilled Steel Disc Brake Kit  
*Heavy Duty Symmetrical housing ends, with 3.347" OD bearing.*

71290 Drilled Steel Disc Brake Kit  
*For 15" bead-lock wheels. Fits MW 58580 housing ends.*

### 4 CALIPER BRAKE KITS

71260 Solid Steel Disc Brake Kit, 4 Caliper  
*MW 58580 Symmetrical housing ends. Four calipers.*

71270 Drilled Steel Disc Brake Kit, 4 Caliper  
*MW 58580 Symmetrical housing ends. Four calipers.*

71275 Drilled Steel Disc Brake Kit, 4 Caliper  
*MW 58580 Symmetrical housing ends. Four calipers. for 15" Beadlock wheel applications.*

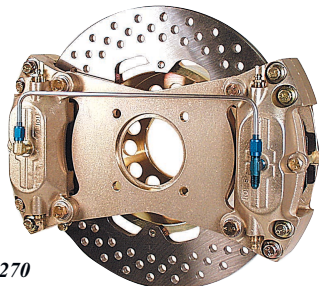

71270

Some kits are available with a dual caliper configuration. Those configurations are designed to give extra holding power at the starting line.

# CARBON/CARBON BRAKES

MW Carbon/Carbon brakes offer the advantage of an extremely light-weight rotor with superior stopping ability. When compared to a standard kit with drilled steel rotors, a Carbon/Carbon brake kit can save you as much as 10 lbs of rotating weight. Carbon/Carbon brakes are unique because both the disc and friction pad are made of the same material, and do not suffer brake fade at elevated operating temperatures. The square drive lug system allows for the expansion of the aluminum mounting hat without applying pressure to the rotor. MW brakes are produced from 2D PAN knit Carbon/Carbon that is superior to the random chopped fiber material used by others. MW Carbon/Carbon kits include MW race proven 4 piston calipers with hard Teflon-Anodized pistons, carbon brake pads with titanium heat shields, billet aluminum mounting brackets, and all the required fasteners.

Brake Technology has changed dramatically over the past few years and Mark Williams Enterprises is in the forefront.

## 81200 Carbon/Carbon Brake Kit

*Fits MW 58580 or Lamb symmetrical type housing ends. 4-1/2", 4-3/4" and 5" bolt circle. Saves 12 lbs. over standard brake kit.*

## 81280 Carbon/Carbon Brake Kit

*Fits Heavy Duty ends with 3.346 O.D. bearing 58595, 58598 and 58599 ends.*



**ALL MARK WILLIAMS 71000 SERIES SINGLE CALIPER REAR BRAKE KITS (SEE PAGE 61) CAN BE PURCHASED**

# BRAKE SYSTEM TECH

## CALIPER ALIGNMENT, CLEARANCE & POSITION

Axle stand out controls the alignment of the brake system and as a result is very critical. To check stand out first verify that the housing ends are perfectly aligned. Install axles and check axle stand out (face of axle flange to face of housing end) as accurately as possible. See the chart below for stand out dimensions for MW brake kits. Stand out should be + .015 of the dimension listed. Shims are available to correct the alignment. 71009 shim goes between the axle flange and brake hat that will move the disc outward .015". 71018 shim goes between the caliper and mount and will move the caliper inboard .015". Misalignment can cause caliper mount deflection, and is one of the causes of a "spongy" pedal. Install wheels to make sure caliper to wheel clearance is adequate on the diameter and face of the wheel. To bleed, the calipers they must be positioned at 3:00 or 9:00 o'clock. This allows the bleeder to be at the highest point of the piston cavity, ensuring that all air is removed from system.

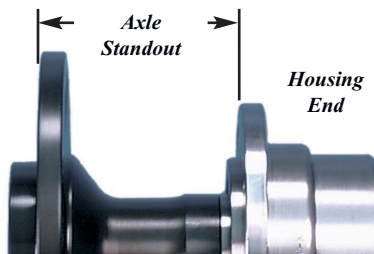

Symmetrical ends	2.834"
Olds ends	2.834"
Large Ford ends	2.500"
Small Ford ends	2.500"
GM 10-12 Bolt ends	2.812"
Mopar ends	2.500"

## PEDAL RATIO & MASTER CYLINDER

The master cylinder bore size influences the obtainable brake line pressure. Recommended master cylinder size when using two typical 4-piston calipers only in the rear is a single outlet, 7/8" bore master cylinder. If single piston front brakes are used in conjunction with two 4-piston calipers in the rear a dual outlet, tandem 1" bore master cylinder is recommended. When using 4-piston calipers front and rear a dual outlet, 1-1/32" bore master cylinder is recommended. Mounting the master cylinder to a frame rail or roll bar is recommended to ensure a solid mount. With the correct master cylinder in place the pedal ratio must be great enough to produce 1200-psi system pressure under severe braking conditions. A pedal ratio verses line pressure calculator is available on the Mark Williams website. We recommend using a pressure gauge connected to the system to verify the maximum available pressure before running the car. If the desired pressure cannot be easily attained the pedal ratio must be increased until the minimum pressure of 1000 psi is easily reached.

## BRAKE LINES & FLUID

Aircraft AN-3 brake lines and fittings are recommended. Only stainless steel braided teflon hose, stainless or seamless steel tubing (3/16" x .028") should be used for brake lines. Lines should be secured to chassis rails to resist vibration and routed in such a way to avoid possible contact with wheels, tires and other moving parts. Joining hard line and braided line or "T"s should be done using a bulkhead fitting and a small tab welded to the chassis. Long runs should be done with hard tubing to avoid expansion of flexible line. The amount of flexible braided hose in the system should be kept to a minimum. See page 64 for AN -3 fittings and brake line. Use of DOT 4 or 5.1 fluid with a high boiling point and lubrication for seals and pistons is recommended. Do not use (DOT5) silicone fluids.

## TROUBLE SHOOTING

### Spongy Pedal Poor Stopping:

- A)** Air in system. Bleed brakes, making sure that the bleed valve is the highest point.
- B)** Disc warped (saucer shaped). Replace.
- C)** Calipers not square with disc. Check housing end alignment, both concentricity and squareness.
- D)** Linings worn on taper. Make sure that caliper is centered over the rotor and the caliper bracket is not deflecting.
- E)** Master cylinder bore too small. Match master cylinder to the system. Check the line pressure.
- F)** Master cylinder deflection. Stiffen master cylinder mounts
- G)** Pedal ratio wrong, low or high pressure

### Brakes are locked up after run:

The piston in the master cylinder is not being allowed to return to the start location. The pressure relief hole is exposed to zero the line pressure. Re-adjust the linkage so that the piston completely returns. Make sure there is a positive stop on the pedal or lever. Do not rely on the retaining ring in the master cylinder for the pedal stop.

### Excessive pad wear, disc shows excess heat:

- A)** System pressure is too low causing a longer pressure applied time to stop. Pressure needs to be high enough to allow wheel lock at any time. Check the ability of the system to generate 1200 PSI.
- B)** Pistons sticking in caliper, clean and overhaul calipers. Annual maintenance is required.



# BRAKE KIT COMPONENTS

All of the components that make up Mark Williams brake kits are available individually. The main components are listed below and on the following page. If there is a part that is not shown please call and a MW tech will help you find the parts.

## 2 & 4 PISTON CALIPERS

MW calipers are all manufactured in house and are cast from the same alloy as the MW 9" Ford cases that has a higher tensile strength than 6061 used in most billet calipers on the market. Pistons are machined from billet aluminum and are Teflon-Hard coat anodized.



81100 MW Quick Change Caliper (ea)  
*For 5/16" to 3/8" thick rotor, no linings*

81100PR MW Quick Change Calipers (pr)  
*For 5/16" to 3/8" thick rotor, with non-asbestos 81130 linings.*

82100 MW Quick Change Caliper (ea)  
*For .812" thick vented rotor, no lining.*

82100PR MW Quick Change Calipers (pr)  
*For .812" thick vented rotor, with non-asbestos 81130 linings.*

83100 MW Single Piston Caliper (ea)  
*For 5/16" to 3/8" thick rotor, no linings.*

83100PR MW Single Piston Calipers (pr)  
*For 5/16" to 3/8" thick rotor, with linings.*

71018 0.015" Caliper Shim  
*To move caliper out for fine adjustments. Goes between caliper and mounting bracket. (Shown Below).*

71009 Shim, Brake Hat  
*Brake adapter to axle flange. (Shown Below).*

## BRAKE HATS & ROTORS

MW brake hats are CNC machined in house from a special aircraft alloy. All hats clear a 3.062" register and are machined to accept MW 5/8" drive studs. Hats locate on a 6.248" maximum axle flange diameter.



71022 Brake Disc Hat (ea)  
*For 70000 series brakes. With 4 1/2", 4 3/4" and 5" patterns.*

81001 Carbon Brake Disc Hat (ea)  
*For 80000 series outboard mount disc brake.*

71002 Cast Iron Brake Rotor (ea)  
*.810" vented for 72000 series brake kit.*

71010 Steel Brake Rotor Slot-Drive (ea)  
*With lightening holes for 71000 series kit.*

71030 Steel Brake Rotor Slot-Drive (ea)  
*With cleaning grooves for 71000 series kit.*

71009 0.015" Rotor Shim  
*To move disc out for fine adjustments. 4-3/4" & 4-1/2" x 5 patterns*

71034 Front Brake Slot Drive Hardware Kit  
*Slot drive drivers and fasteners (recommended with new rotors)*

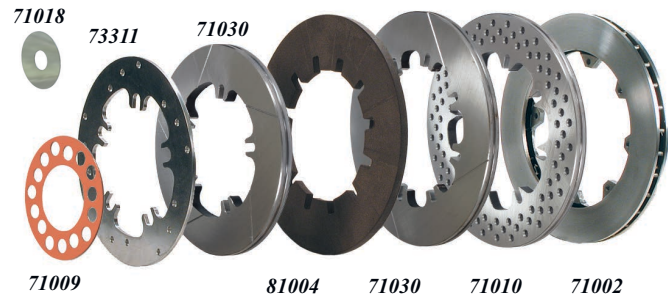

71035 Rear Brake Slot Drive Hardware Kit  
*Slot drive drivers and fasteners (recommended with new rotors)*

73311 Steel Floating Brake Rotor (ea)  
*For 73000 (.325 thick) series kit.*

73104 Carbon Floating Brake Rotor (ea)  
*For 73100 & 73400 brake kits. (Not shown)*

75009 Steel Brake Front Rotor Slot-Drive(ea)  
*With cleaning grooves. For 75000 series kit with slot drive attachment.*

81034 Carbon Brake Rotor (ea)  
*For 81000 series brake kit, 95400 & 95555 floater kits, .437 thick.*

## BRAKE LININGS



9-707-150 Lining, Lamb Strut, Pre '85 (4 ea)

9-707-625 Lining, Lamb Strut Post '85 (4 ea)

73004 Lining, MW Front Caliper (ea)  
*For MW 2 piston billet front caliper in spindle mount kits.*

73109 Carbon/Carbon Lining (ea)  
*For MW 73002 floating front caliper. (Not shown)*

81030 Carbon/Carbon Lining (ea)  
*Includes Titanium steel backing plate, MW carbon brake system*

81130 Ferodo Hi-Friction Lining (ea)  
*For MW 81100,81200 caliper, Ferodo non-asbestos high friction this in the normal lining shipped with brake kits.*

81136 Bushing for 81130 Linings, (ea)  
*Use with 81135 lining in JFZ or Wilwood calipers.*

83120 Lining, 2 Piston Front Caliper (ea)

# BRAKE SYSTEM COMPONENTS

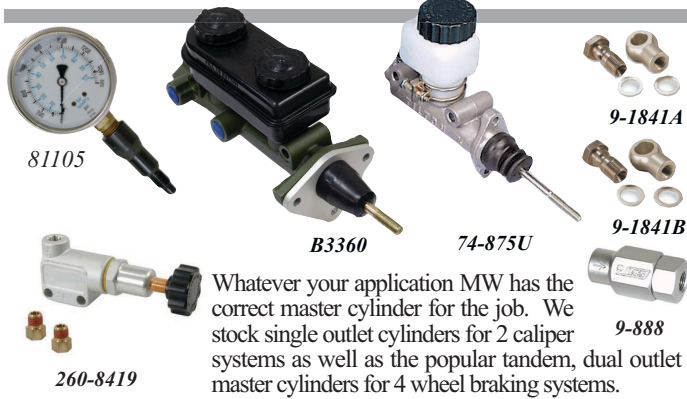

Whatever your application MW has the correct master cylinder for the job. We stock single outlet cylinders for 2 caliper systems as well as the popular tandem, dual outlet master cylinders for 4 wheel braking systems.

B3359 1 1/8" Dual Master Cylinder

## CALIPER & MASTER CYLINDER PARTS

- 6446 Bleed Screw, 1/4" Thread (ea)
- 9400 Bleed Screw, 3/8" Thread (ea)
- 75099 Dust Cap Socket (ea) (Front Brake)
- 75002 Front Hub Dust Cap (ea) (Front Brake)
- 81101 MW Caliper Half, Inboard
- 811EX Rebuilt MW Caliper (Exchange)
- 81102 MW Caliper Half, Outboard
- 81104 MW Caliper Bridge Bushing (ea)
- 81103 Piston, For MW Caliper (ea)

- B3360 1 1/32" Dual Master Cylinder
- 81105 Caliper Pressure Test Gauge  
*Recommended Checking pressure settings at the wheel. Invaluable troubleshooting aid*
- 9-888 Residual Pressure Valve  
*2 lb. Lamb for use with M-W, JFZ or Wilwood calipers*
- 74-750U 3/4" Tilton Master Cylinder Kit  
*Accepts side or flange mounting with remote or fixed reservoir and -3 outlet fitting.*
- 74-875U 7/8" Tilton Master Cylinder Kit
- 74-100U 1" Tilton Master Cylinder Kit
- 9-1841A Lamb 9/16" Banjo Fitting
- 9-1841B Lamb 1/2" Banjo Fitting
- 260-8419 Brake proportioning valve, knob adj

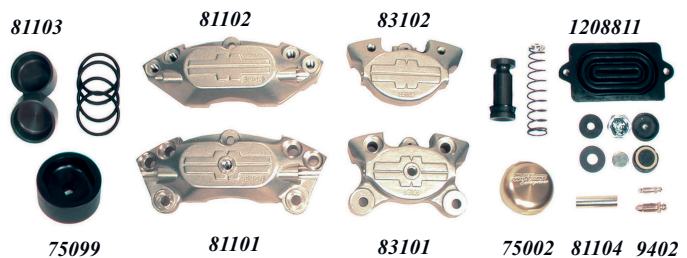

- 81170 O-Ring Kit for One MW Caliper
- 83101 MW Caliper Half, Inboard
- 83102 MW Caliper Half, Outboard
- 1208811 Overhaul Kit-3/4" Airheart Cylinder

## BRAKE LINES AND FITTINGS



- 0187X028 -3 Stainless Tubing (ft)  
*3/16" X .028" tube, for the long brake line runs*
- 0300 -3 Stainless Hose (ft)  
*3/16" PTFE brake line hose per foot*
- 1100 -3 Straight Hose End
- 1110 -3 45 Degree Hose End
- 1120 -3 90 Degree Hose End
- 2048 -4 to -3 Straight Union
- 2050 -3 Straight Union
- 2060 -3 Union Tee
- 2083 1/8" Pipe Nipple
- 2187 -3 Tee Fitting  
*3/16" tee with 1/8" pipe on the side*
- 2511 -3 Straight Adapter  
*3/16" hose end to 1/8" pipe (caliper fitting)*
- 2513 -4 Straight Adapter  
*-4 JIC to 1/4" NPT*
- 2610 -3 90 Degree Adapter  
*3/16" hose to 1/8" pipe 90 elbow*
- 2769 -3 Bulkhead Straight
- 2808 -3 Bulkhead Tee
- 2815 -3 Bulkhead Tee  
*Bulkhead on the run.*
- 2921 -3 Bolt For Banjo
- 2949 -3 Banjo Brake Adapter
- 3554 -3 Tube Flair Nut, (6)
- 3556 -3 Bulkhead Nut, (2)
- 3642 -3 Banjo Gasket, (2)
- 3669 -3 Tube Sleeve, (6)
- 3750 Line Clamp-Hose 3/16 (6)
- 3755 Line Clamp-Tubing 1/4 (6)
- 10324-03 Inverted Flare Adapter  
*AN -3 to 3/16" inverted flare. For OEM lines*
- 10100-03 Inverted Flare Adapter  
*AN -3 to 10mm inverted flare. For OEM lines.*

Correctly plumbing your brake system is very important to brake performance. Quality components are the first step in doing it right. AN-3 is the recommended size for a brake system and MW stocks everything you will need. (Note flares must be 37°)

### SWEDGED BRAKE LINES



Order Line with (dash) end fitting for each end. Base line is 12" long for each additional foot length.

- FBM2945 -3 to Fe. 10mm Concave
- FM10324-03 Invert. Flare Adapter
- 0300-1-1 Straight X Straight
- 0300-1-2 Straight X 45°
- 0300-1-3 Straight X 90°
- 0300-2-2 45° X 45°
- 0300-2-3 45° X 90°
- 0300-3-3 90° X 90°





# DRIVESHAFT ASSEMBLIES

Many of the nation's leading drag racers rely on Mark Williams's driveshafts and for good reason. MW has been building race-winning driveshafts for over 40 years and offers a driveshaft for nearly every application. From the 4130 chromoly shafts capable of handling Pro Mod/Nitro Coupe power to the lightweight 7075 aluminum shafts for Pro Stock, Comp, Super Stock or any application where rotating weight is a concern. All work, from fabrication to balancing, is done in-house at MW's plant and you can be assured of unmatched quality and prompt delivery. Most MW Driveshafts meet the SFI 43.1 specifications.

When placing an order for Mark Williams driveshaft assemblies please refer to the diagram below for the required dimensions. The "E" dimension is the preferred measurement but remember your 1350 or 1480 series pinion yoke must be in place when measuring, (our pinion yoke might not be the same length as stock yokes). If ordering by the "C" dimension, the MW transmission yoke should be used. Our trans yoke lengths may not be the same as a stock yoke. The "E" dimension can be used but make sure you have the pinion yoke you will utilize.

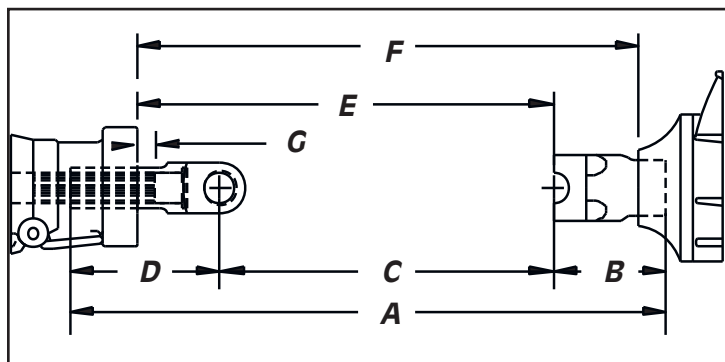

- A** End of trans yoke to end of pinion yoke.
- B** End of pinion yoke to U joint center.
- C** U joint center to U joint center.
- D** End of trans yoke to U joint center.
- E** Trans seal to U joint center.
- F** Trans seal to pinion seal.
- G** Trans seal to end of output shaft.

## CHROMOLY & MILD STEEL

When it comes to a bulletproof driveline the Mark Williams chromoly driveshaft is the strongest. A chromoly shaft is 75% stronger than commonly used 1020 DOM material. To ensure the quality of the material, the 4130 condition HT tubing used is manufactured by domestic mills to meet the MIL-6736-B-HT-125 specification. The perfect companion to MW's chromoly tubing is the MW produced, 4130 forged weld yokes used in each assembly. These weld yokes are produced in-house to exacting tolerances to provide the proper press fit in the chromoly tube. MW weld yokes and chromoly tubing are assembled using a specially built alignment/assembly fixture, then carefully joined using an automated cold wire TIG process. Precision 1350 or 1480 series U-joints are then installed along with the forged, 100% machined 4340 heat-treated transmission yoke. Each assembly is High-Speed electronically spin balanced at a RPM that represents operating speed, to G30 industry tolerances.

The finished product is a driveline capable of handling today's most powerful vehicles. (Prices are less transmission yoke.) All 4130 Chromoly driveshafts meets and exceeds the SFI Spec 43.1.

- 39650 Mild Steel Driveshaft Assembly**  
3-1/2" O.D. x .065 DOM mild steel shaft, Spicer weld yokes and lube for life 1350 series U-joints.

---

- 39640 Mild Steel Driveshaft Assembly**  
4" O.D. x .083 DOM mild steel shaft, Spicer weld yokes and lubed for life 1350 series U-joints.

---

- 39800 3" Chromoly Driveshaft Assembly**  
3" O.D. x .083 4130 chromoly shaft. MW 4130 forged steel weld yokes and lubed for life 1350 series U-joints. SFI 43.1



**Steel Shafts**  
For many applications shaft weight is not a factor. For most bracket cars consistency is the goal so the performance advantage of lighter materials is usually not important.



- 39850 3-1/2" Chromoly Driveshaft**  
3-1/2" O.D. x .083 4130 chromoly shaft. MW 4130 forged steel weld yokes and lubed for life 1350 series U-joints. SFI 43.1

---

- 39880 3-1/2" Chromoly Driveshaft 1480 Joint**  
3-1/2" .083" wall 4130 HT Tube, Precision U-Joints for high Powered applications. SFI 43.1.

**Caution:** Steel with the smaller diameters has the lowest critical speed properties. For long shafts it is necessary to use a large diameter for high RPM requirements. Check the speed chart page 72 before ordering

# ALUMINUM ACCU-BOND™ DRIVESHAFTS



39550 7075  
Aluminum  
Driveshaft



Mark Williams Accu-Bond™ aluminum driveshafts are custom built with the super tough 7075 or 6061 aluminum tubing and fitted with special MW forged or Billet 7075-T6 end yokes. The end yokes are mated to the tubing using our patented, (USPS 7,485,045 B2) Accu-Bond™ bonding process. This allows the end fittings to be produced from high-grade 7075 aluminum, increasing the strength (the normal weak link of any aluminum driveshaft). In addition, the use of aluminum allows a 50% weight reduction compared to a steel shaft.

All shafts are high-speed balanced to G30 specifications in relation to the actual operating speeds on MW's high-speed balancer. Balance weights are attached with our unique system of bolt-on balance weights. Accu-Bond™ shafts are available in both 3 1/2" and 4" diameters. The 4" diameter should be used for longer shafts to avoid critical speed limitations (the rpm at which the shaft wants to "jump rope").

The combination of the larger diameter and high strength of 7075 materials allow for a thinner wall thickness, resulting in a very light assembly. The 7075 shaft is ideal for applications where weight and critical speed are an issue. The 6061 Accu-Bond™ driveshaft is an economical alternative to the 7075-bonded shaft. This shaft has slightly lower operating speeds and ultimate strength compared to the 7075 shaft, but is adequate for most high-powered applications. Prices are less transmission yoke, which is required for proper balancing. All Accu-Bond 7075 and 6061 driveshafts are SFI 43.1 certified.

39555 Accu-Bond™ 7075 Driveshaft  
3-1/2" O.D. x .110" 7075 aluminum, MW forged 7075-T6 end yokes and cold forged precision 1350 series U-joints. Meets SFI 43.1

39985 Accu-Bond™ 6061 Driveshaft  
3-1/2" O.D. x .125" 6061-T6 aluminum tube, MW forged 7075-T6 end yokes and cold forged precision 1350 series U-joints. Meets SFI 43.1

39550 Accu-Bond™ 7075 Driveshaft  
4" O.D. x .100" 7075 aluminum tube, MW forged 7075-T6 end yokes and cold forged precision 1350 series U-joints. Meets SFI 43.1

39990 Accu-Bond™ 6061 Driveshaft  
4" O.D. x .125" 6061-T6 aluminum tube, MW forged 7075-T6 end yokes and cold forged precision 1350 series U-joints. Meets SFI 43.1

39890 Accu-Bond™ 7075, 1480 joint Driveshaft  
4" O.D. x .100" 7075 aluminum tube, billet 7075-T6 end yokes and cold forged precision 1480 series U-joints. Meets SFI 43.1

## CARBON FIBER DRIVESHAFTS



39100 Carbon  
Fiber Driveshaft



### Carbon Fiber Shafts

- 1) Higher critical speed rating over aluminum shafts
- 2) Can be used for extremely long shafts at high RPM.
- 3) Best power to shaft weight rating.

39155 Carbon Fiber Driveshaft  
4".OD. Carbon Fiber shaft, MW 7075-T6 forged aluminum end yokes and cold forged precision 1350 series U-joints. meets SFI 43.1.

In keeping with the advances in driveline technology, Mark Williams Enterprises offers a carbon fiber driveshaft assembly. The special Mark Williams aluminum end yokes are manufactured to extremely tight tolerances for a precise fit into the carbon fiber tube. The end yokes are then installed in the carbon fiber tube using a proprietary, patented bonding system. A custom built assembly fixture ensures perfect alignment or "phasing" of the end yokes during this process. MW's precision 1350 series U-joints, are installed along with the transmission yoke and the assembly is electronically balanced using the race proven bolt-on weight system. The stiffness of the carbon fiber material allows for higher critical speeds thus making it ideal for longer applications such as Pro Stock Trucks etc. Price is less transmission yoke. MW carbon fiber driveshafts are SFI 43.1 certified when using a MW Yoke.

Our torsion testing ability is unparalleled in the industry. We are involved in special design and manufacturing processes for all types of driveline applications. Our in house torsion testing machine allows testing of all types of maximum torsion and cycle load tests.

Each Accu-Bonded™ shaft is load and cycle tested to assure performance quality before shipping. A certificate of test accompanies each shaft. As a support service we will perform proof testing for any MW produced driveshaft free of charge.

### DRIVESHAFT TESTING



## 1480 ALUMINUM & CHROMOLY DRIVESHAFTS

1480 series Drive Shafts, Transmission and Rear Yokes is the next step up for Pro-Mod and other High Powered combinations. The oversize joints create a driveshaft that is up to 40% stronger than 1350 series joints. The 1480 series shafts are available in 3-1/2" Chromoly and 4.0" 7075 Aluminum Accu-Bond™ shafts.

Pair either driveshaft with our 1480 series transmission yoke and pinion yokes for the ultimate in precision and strength. Steel pinion yokes are available for 9" Ford 35 spline pinion, GM 14 Bolt rears, and MW 11"40 spline pinion. Also we have Aluminum 7075 Pinion yokes for 9", 9-1/2", 10" Ford 35 spline and MW 11"40 spline pinion. Mating U-bolt kits are required for the pinion yokes. Transmission yokes currently available are 16, 32 and 35-spline Lenco/B&J, 32-spline Liberty roller-bearing yokes, 32-spline Turbo 400, and 40 spline. Drive Shafts are priced less transmission yoke.

MW has raised the bar again for quality and strength in driveline products.

**39880 3-1/2 1480 Chromoly Driveshaft**  
*3.5" x 0.083" wall chromoly tubing. With cold forged precision 1480 universal joints and balancing,(Trans yoke sold separate). Meets SFI 43.1*

**39890 7075 Driveshaft**  
*Accu-Bond™ 4" O.D. x .100" 7075 aluminum tube, MW billet 7075-T6 end yokes and cold forged precision 1480 series U-joints. (Trans yoke sold separate) Meets SFI 43.1*



## 1480 SERIES TRANSMISSION YOKES

Mark Williams Heavy Duty 1480 series transmission yokes are 100% machined from hot-forged chromoly. The Heat-treat hardness is compatible for use in roller bearing tail housing transmissions. Shot Peening after heat-treating gives a added fracture resistant durability.

Similar to our 1350 series yokes, they feature the same Patented Reduced Mass™ profile with the larger 1480 U-joint that is 40% stronger than standard 1350 U-joints. These yokes are designed for high power applications where strength is more important than the assembly's weight. Matching pinion yokes are available for popular differential applications.

**39070 MW 1480 Series Transmission yoke**  
*16-spline, Lenco and G-Force, 1480 joint, D=4.50"*

**39071 MW 1480 Series Transmission yoke**  
*32-spline, Lenco, 1480 joint, D=4.50"*

**39074 MW 1480 Series Transmission yoke**  
*32-spline, Liberty, Jerico 1480 joint, D=6.15"*

**39076 MW 1480 Series Transmission yoke**  
*32-spline, Turbo 400, 1480 joint, D=6.15"*

**39079 MW 1480 Series Transmission yoke**  
*35-spline, Lenco, 1480 joint, D=4.25"*

**39078 MW 1480 Series Transmission yoke 40 spline**  
*40 spline Lenco MW std spline 2.375" barrel, 1480 joint, D=5.50"*

**39085 MW 1480 Series Transmission yoke 35 spline**  
*35 spline Liberty Trans 1.9685" barrel, 1480 joint, D=6-1/8"*



**39076  
Turbo 400**

# TRANSMISSION YOKES

MW heavy-duty transmission yokes have been designed to incorporate Spicer 1350 series U-joints and are forged from heat treated 4340 steel. All yokes are 100% machined in house on MW's state-of-the-art CNC machines. Special fixtures are used to guarantee that all machining is done in relationship to the spline pitch diameter. This assures concentricity and produces a yoke that is symmetrical and balanced for smooth operation. The yokes are then re-heat treated to over 200k PSI and U-joint cup bores are honed to exact limits and the bushing/seal surface is ground with special fixtures assuring concentricity with the spline pitch diameter.

Like all MW product's they are laser engraved with part numbers and batch numbers that allow complete trace-ability. A new end of spline sealing feature features a o-ring seal with a tapered retaining ring that forces a aluminum plug against the seal. This improved method has proven to eliminate fluid seepage.



- 39002 MW Chrysler Transmission Yoke  
30 spline, for 1350 series U joint. Mopar, Doug Nash and Liberty trans. "D" = 6-1/8" 1.680" Dia.

---

- 39004 MW Turbo 400 Transmission Yoke  
32 spline, for 1350 series U joint. Turbo 400 and Super T-10 trans. 1.886" barrel for roller or bushing "D" = 5-3/4" 1.886" Dia

---

- 39005 MW Powerglide Transmission Yoke  
27 spline, for 1350 series U joint. Powerglide and Turbo 350 trans. "D" = 5-13/16" 1.5035" Dia

---

- 39013 MW Lenco Transmission Yoke  
32 spline, for 1350 series U joint. Lenco trans. "D" = 4"

---

- 39015 MW Lenco Transmission Yoke  
16 spline, for 1350 series U joint. Lenco trans. "D" = 4"

- 39020 MW C-6 Ford Transmission Yoke  
31 spline, for 1350 U joint. C-6 & Toploader trans. "D" = 6-1/8" 1.6845" Dia

---

- 39021 MW Lenco Transmission Yoke  
35 spline, for 1350 series U joint. Lenco trans. "D" = 4"

---

- 39022 MW Ford C-4 Transmission Yoke  
28 spline, for 1350 series U joint. C-4 trans. "D" = 5-13/16" 1.4990" Dia

---

- 39031 MW 904 Torqueflight  
26 Spline, for 1350 Series U joint, 904 Torqueflight, "D=6-1/8" 1.559" Dia

---

- 39040 MW G-Force Transmission Slip Yoke  
16 spline, for 1350 series U joint. G-Force trans. "D" = 3 1/2"

---

- 39060 MW G-Force Transmission Slip Yoke  
32 spline, for 1350 series U joint. G-Force trans. "D" = 3 1/2"

# ROLLER BEARING TAIL-HOUSING YOKES

These MW yokes have the additional heat-treating and special outside diameter, to be compatible with the needle bearing tail housings used by many of the transmissions manufacturers. These are compatible for use with Jerico, Dedenbear, Liberty and several NASCAR transmission manufacturers.

Please note that there is a difference in diameters between a needle bearing tail housing, and a bushed tail housing, for same brand transmissions.



Quick release yoke for Liberty, Jerico and other transmission utilizing a 32 spline out put with roller bearing tail housing with a 1.888" diameter bearing. This yoke utilizes the 2nd Gen™ U-Bolt that is included with the yoke.

- 39032 Hardened Mopar-Liberty Slip Yoke  
30 spline. Liberty trans. 1.750" diameter "D" = 6-1/8"

---

- 39034 Hardened 32 Spline Slip Yoke  
32 spline. Jerico and G Force trans. 1.885" diameter "D" = 6-1/8"

---

- 39035 Hardened Powerglide Slip Yoke  
27 spline. Powerglide with needle bearing Tail-Housing. "D" = 5-13/16"

---

- 39057 Hardened 32 Spline Slip Yoke  
32 Spline, Jerico roller bearing 1.888" Diameter. "D" = 6-1/8"

---

- 39067 Hardened 32 Spline Slip Yoke  
32 Spline, roller bearing 1.888" Diameter. "D" = 6-7/16" Major Diameter spline fit one spline omitted for Jerico needle bearing tail-housing.

---

- 39068 Hardened 32 Spline Slip Yoke  
32 Spline, roller bearing 1.888" Diameter. "D" = 6-7/16"  
Two splines omitted, side fit splines 1.888" barrel Diameter

---

- 39069 Hardened 32 Spline Slip Yoke  
32 Spline, roller bearing 1.888" Diameter. "D" = 6-7/16" Major Diameter spline fit Two splines omitted for needle bearing tail-housing.

---

- 39157 Quick Release 32 Spline Roller Bearing  
32 spline. with 1.888" D" = 6-7/16 with U-Bolts

---

- 39112 Replacement Steel Caps, Gen II, stud(pr)



## RAPID RELEASE YOKES

The MW Rapid Release yokes can be a real time saver during those quick transmission changes. They allow the driveshaft to be disconnected at the transmission rather than at the pinion, plus the cap design prevents over tightening and possible damage to the U joint cups. These yokes accept the 1350 series Spicer U joint and are the lightest and most compact units of this type on the market. Each yoke comes with caps and fasteners. Care must be exercised not to mix U-joint caps and maintain indexing after shaft is balanced. MW built driveshafts with these yokes have identifying index marks.

- 39102 Mopar Rapid Release Yoke  
30 spline. Mopar, Doug Nash and Liberty trans. "D"=6-1/8"
- 39104 Turbo 400 Rapid Release Yoke  
32 spline. Turbo 400 and Super T-10 trans. "D"=5-3/4"
- 39105 Powerglide Rapid Release Yoke  
27 spline. Powerglide and Turbo 350 trans. "D"=5-13/16"
- 39113 Lenco Rapid Release Yoke  
32 spline. Lenco trans. "D"=4"

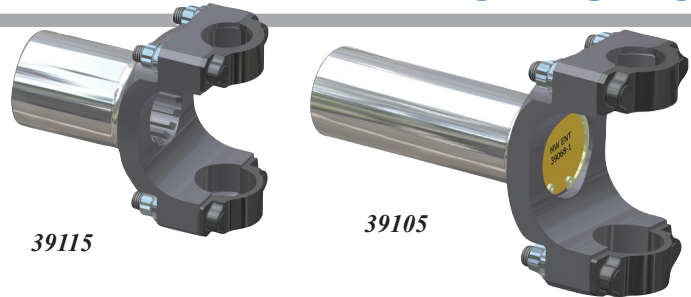

- 39115 Rapid Release Yoke  
16 spline. Lenco trans. "D"=4"
- 39120 Ford Rapid Release Yoke  
31 spline. C-6 and Toploader trans. "D"=6-1/8"
- 39135 Dedenbear PG Rapid Release Yoke  
27 spline. Powerglide trans. with Dedenbear Tail-Housing "D"=5-13/16"
- 39157 Quick Release 32 Spline Roller Bearing  
32 spline. with 1.888" D" = 6-7/16"
- 39110 Replacement Steel Caps, Bolt on(*pr*)
- 39112 Replacement Steel Caps, Gen II, stud(*pr*)

## PINION YOKES

MW steel pinion yokes are CNC machined from heat treated 4340 steel forgings and they accept the Spicer 1350 series U-joint. Special tooling ensures that every yoke is machined concentric to the pinion spline for smooth operation. Yokes have provision for computer pick up rings available separately. Every MW pinion yoke can use conventional Spicer 3/8" diameter U-bolts, or the new 2nd Gen™ alloy steel kit to retain the U-joint.

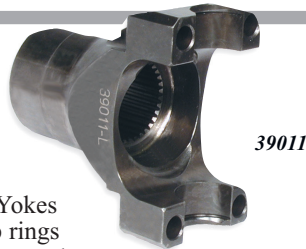

- 39003 MW 8.5" GM 10 Bolt Pinion Yoke  
30 spline, for 1350 series U joint. "B" = 3-3/16"
- 39006 MW GM 12 Bolt Pinion Yoke (*long*)  
30 spline, for 1350 series U joint. "B" = 3-7/8"
- 39038 MW GM 12 Bolt Pinion Yoke (*short*)  
30 spline, for 1350 series U joint. "B" = 2-7/8" Recommended yoke

- 39008 MW 9" Ford Pinion Yoke, 28 spline  
28 spline, for 1350 series U joint. "B" = 3-7/8". Note: 57604 shim required if yoke is used with stock support.
- 39011 MW 9" Ford Pinion Yoke, 35 spline  
35 spline, for 1350 series U joint. "B" = 3-7/8"
- 39014 MW Dana 60 Pinion Yoke  
29 spline, for 1350 series U joint. "B" = 3-1/32"
- 39016 MW 8-3/4" Mopar Pinion Yoke  
10 spline, for 1350 series U joint. "B" = 3-1/2"
- 39018 MW '57-'64 Olds/Pontiac Pinion Yoke  
13 spline, for 1350 series joint. "B" = 3.160"
- 39023 MW 8.8" Ford Pinion Yoke  
30 spline, for 1350 series U joint. "B" = 3-9/32"
- 39037 MW 11" Rear  
40 Spline, for 1350 Series U-Joint "B"=3.830"
- 39025 MW 9" Pinion Yoke 1330 series Joint  
28 spline for MW support, 1330 Ford joint (3-5/8 X 1-1/8") "B"=3-1/2"

## BILLET ALUMINUM YOKES

- 39906 MW Aluminum 12 Bolt Pinion Yoke  
30 spline, for 1350 series U joint. "B"= 3 7/8"
- 39908 MW Aluminum 9" Ford Pinion Yoke  
28 spline, for 1350 series U joint. "B"= 3-7/8"
- 39911 MW Aluminum 9" Ford Pinion Yoke  
35 spline, for 1350 series U joint. "B"= 3-7/8"
- 39936 Low Friction 9" Ford Pinion Yoke . . . . .295.00  
32 spline, for 1350 series U joint. B"= 3-7/8" This is the aluminum yoke used with the 57022 series Thirdmembers and the MWE-XXX 9-1/2" Gear sets.
- 39972 9" Ford Pinion Yoke 1480 Joint . . . . .325.00  
35 spline, for 1480 series U joint. B"= 3-7/8" for 9",9-1/2", Gear sets.
- 39973 11" Modular Pinion Yoke 1480 Joint . . . . .325.00  
40 spline, for 1480 series U joint. B"= 3-7/8" for 11", Gear sets.

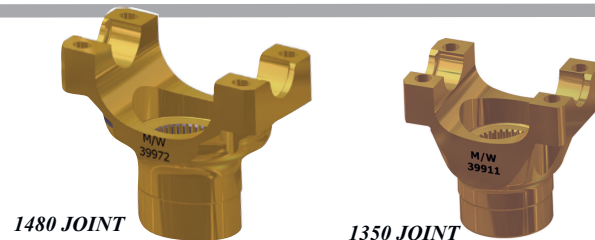

All MW aluminum yokes are CNC machined from 7075-T6 billet materials and have the MW Gold Coat process. These pinion yokes mate to the 39912 Gen II U-Bolt kits. Models are available for 1350 and 1480 series universals joints.

## 1480 SERIES PINION YOKES

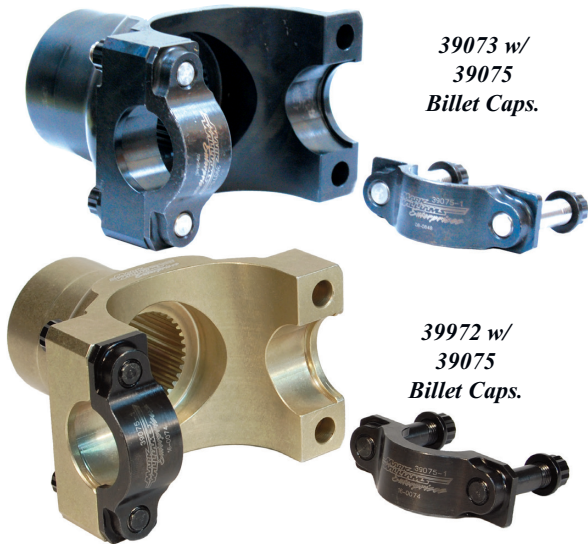

MW Extra Heavy Duty pinion yokes are precision machined from Alloy Heat-Treated steel forgings. They feature a 1480 series U-joint that is 40% stronger than the standard 1350 U-Joints. Special fixtures ensure that every yoke runs concentric to the splines. Shot Peened for surface strength improvement. For extra strength, the 39075 Billet Steel Cap Kit is required rather than replace standard straps.

39072 MW 1480 Series 9" Ford Pinion Yoke  
35 spline, for 1480 series U-Joints B=3-7/8"

39073 MW 1480 Series 11" Pinion Yoke  
40 spline, for 1480 series U-Joints B= 3-7/8"

39084 MW 1480 Series 14 Bolt GM Pinion Yoke  
**NEW!** 30 spline, for 1480 series U-Joints B= 3.7" early 14 Bolt GM Truck

39075 Cap Kit for 1480 Series Yokes  
Billet steel cap kit for 1480 series pinion yokes

39972 MW 1480 Series Aluminum 9" Ford Pinion Yoke  
35 spline, for 1480 series U-Joints B=3-7/8"

39973 MW 1480 Series Aluminum 11" Pinion Yoke  
40 spline, for 1480 series U-Joints B= 3-7/8"

## NASCAR YOKE & PULLEY

39024-1 9" NASCAR Pinion Yoke **Long**  
9" Ford 28-spline. "B"=3-7/8", Long Yoke with Threads.

39053-1 9" NASCAR Yoke **Short**  
9" Ford 28-spline. "B"=3-9/16" Nickel Plated.

39063 9" NASCAR Yoke, **Short**  
9" Ford 28-spline. "B"=3-9/16" Nickel Plated. For billet caps.

39064 9" NASCAR Yoke, **Long**  
9" Ford 28-spline. "B"=3-7/8" For 39111 billet caps.

39924-1 9" Aluminum **Long**  
9" Ford 7075-T6 billet, 28-spline. "B"=3-7/8" with Threads.

### RETENTION U-BOLTS & STRAPS

39111 Billet U-Bolt Kit for NASCAR  
Billet caps with studs and 12 point nuts (pr).

MW NASCAR yokes are machined from 4340 forgings and designed to use Spicer 1350 U-joint and straps or MW u-bolt kit. V-belt pulleys are optional. These yokes are designed for Daytona type pinion supports or MW's 57690 nodular iron ball bearing support (yokes must be modified if used with any other MW support). Two new yokes accept a U-Bolt kit with studs for added security.



39064 shown with 39111 billet caps



39024 w/strap kit and optional pulley

## OFF-ROAD DRIVELINE COMPONENTS

With the increased popularity of off road events M/W is proud to offer several drive line products. For the Atlas transfer case we have yokes and CV flanges. For the 14 Bolt pinion yokes and CV flanges. Look for new problem solving products for you're off road drivelines in the future.

39086 Atlas Transfer Yoke  
**New!** 32-spline. 1350 Spicer Joint size

39087 Atlas Transfer Yoke  
**New!** 32-spline. 1410 Spicer Joint size

39088 Atlas Transfer Yoke  
**New!** 32-spline. 1480 Spicer Joint size

39084 GM Truck 14 Bolt Pinion Yoke  
**New!** 30-spline. 1480 Spicer Joint size

39085 GM Truck 14 Bolt Pinion Yoke  
**New!** 30-spline. 1350 Spicer Joint size

39331 Pinon CV flange 930 Size  
**New!** 35-spline. for 930 Series 15 CV Joint



39086



39085



39332



39334

39332 Pinon CV flange 934 Size  
**New!** 35-spline. for 934 Series 21 CV Joint

39333 Pinon CV flange 30 Size  
**New!** 35-spline. for Series 30 CV Joint

39334 Atlas CV flange 930 Size  
**New!** 32-spline. for Series 15 CV Joint

39335 Atlas CV flange 934 Size  
**New!** 32-spline. for Series 21 CV Joint

39336 Atlas CV flange 30 Size  
**New!** 32-spline. for Series 30 CV Joint

**MARK WILLIAMS** Enterprises®

## COMPUTER PICKUP ASSEMBLY

The MW computer pickup assembly provides driveshaft rpm data from the pinion. Compatible with most on board computer systems. CNC machined and black anodized these collars will accept 1 to 4 magnets. Magnets slip in from center, a plastic plug holds the magnet outward (included with magnet). The 57642 collar has 1.875" I.D. while the 57645 collar has a 2.187" I.D. 57656 has a 2.375 I.D. Most MW yokes and couplers are designed to use one of these collars. Specify number of magnets required. 1, 2 or 4.



- 57640 Assembly Std Pinion (collar & bracket)
- 57641 Bracket for 9" Ford Thirdmember
- 57642 Magnet Ring (std pinion) 1.875" I.D.
- 57643 Magnet (1/4" dia. x 1/4" long)
- 57644 Proximity Sensor Assembly
- 57645 Magnet Ring (lrg pinion) 2.187" I.D.
- 57646 Assembly Lrg. Pinion (collar & bracket)
- 57656 Magnet Ring, MW 11" 40 Spline (2.375" I.D.)

## HIGH RESOLUTION HALL EFFECT SENSOR

The new Mark Williams hall effect driveline sensor features a lightweight, nickel plated trigger ring and a solid state pickup. 12 pulses per revolution deliver accuracy 3 times higher than a 4 magnet system, and the system is less prone to errors due to vibration. The kit includes everything needed to install the system on a 9" Ford, including the bracket and updated seal.

57685 12 Point Hall Effect Sensor Ring

*Fits 28 spline 9" Ford pinion, includes seal*

57686 12 Point Hall Effect Sensor Ring

*Fits 32 spline low drag 9" Ford pinion (MW), includes seal*

57687 12 Point Hall Effect Sensor Ring

*Fits 35 spline 9" Ford large pinion, includes seal*

57688 Hall Effect Sensor Switch

*Fits 9" includes bracket*

*\*Older RacePak units may not be compatible without an update from RacePak.*

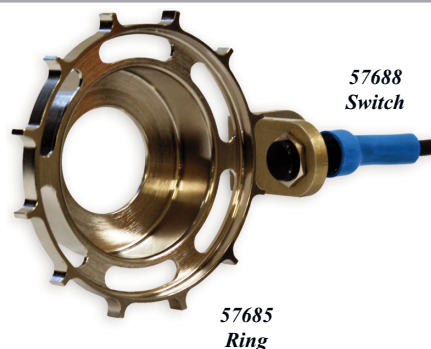

57688  
Switch

57685  
Ring

## Hi-Speed Balancing



Many of our driveshaft improvement is result in utilizing use of our highly sophisticated balancing machine This enables Mark Williams Enterprises technicians to accurately balance shafts that simulate operating conditions. The device features a built-in "dyno" that can place loads on the shaft and is adjustable to universal joint operating angle The process allows Mark Williams to balance driveshafts and check the universal joint preload more accurately than is possible through conventional processes thus simulating actual running conditions. This equipment is used on all driveshafts manufactured by Mark Williams Enterprises. Mark Williams quality check and balance any existing 1350 series universal shaft, regardless of manufacturer, for a nominal fee.

BAL Straighten and High Speed Driveshaft Balance

BAL-SPIN Spin Test and Balance to NASCAR Specifications

# DRIVESHAFT TIPS

There are a couple important factors that will ensure the best possible performance from your driveshaft assembly. One is U-joint operating angles and the other is shaft critical speed. Both are explained below. Use these tips to avoid common driveline mistakes.

## OPERATING ANGLES

The driveline arrangement in most racing applications is known as a parallel, zero degree phasing driveshaft. In order to obtain the minimum power loss from the operation of the universal joints, two things must be addressed with regard to operating angles. First is making sure shaft centerlines are parallel. Second is the actual operating angle of the U-joints. The centerline of the engine/transmission (ØA) should be kept as parallel as possible to the pinion centerline (ØB). This ensures both U-joints are operating at the same angle.

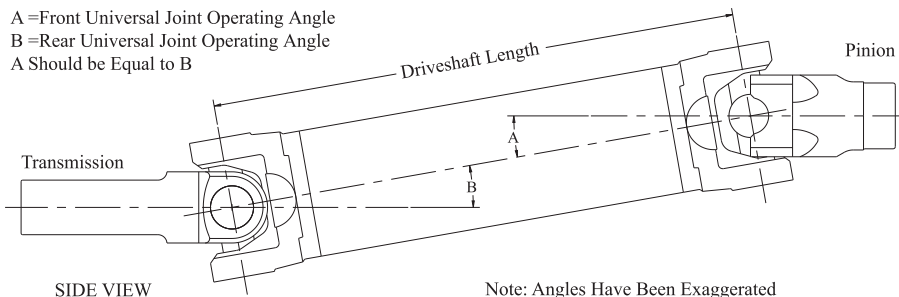

Keeping these centerlines parallel throughout the suspension travel would be ideal but is very hard to do. The type of rear suspension will have an effect on maintaining a parallel condition. A 4-link suspension system is the best when it comes to the pinion maintaining its angle through its travel up and down. Ladder bar and torque arm systems create unique operating angles as the suspension moves since they move from a single point. In any case, the pinion angle should be set to match the engine/trans angle with the car at its ride height by placing a digital level on a machined surface of the engine then on the pinion yoke. Adjust bars or shim accordingly. u-joint operating angles should be kept at a minimum. In general operating angles should be 2° or less for racing applications and should be within 1/2° of each other. Greater operating angles create a power loss and can cause vibration at high RPMs. Again a 4-link is the best at keeping the U-joints operating at the same angles. Increasing the operating angle will also affect the critical speed characteristics of a driveshaft. There is a general misunderstanding about "dropping the pinion down" several degrees. This is a practice that should be applied only to leaf spring cars without any traction control devices where springs can "wrap" and change pinion angle. This practice would not apply to 4-link, ladder bar or torque arm equipped cars. Failure to maintain matched and minimum operating angles increase erratic non-uniform output velocity from the driveshaft to the differential.

## CRITICAL SPEED

MW Part Number	44"	46"	48"	50"	52"	54"	56"	58"	60"
39155 4.0" Carbon Fiber	14173	12940	11860	10910	10070	9320	8650	8060	7521
39550 4" Bonded 7075	10620	9700	8890	8170	7540	6980	6480	6040	5630
39555 3.5" Bonded 7075	8590	7850	7190	6620	6110	5660	5250	4890	4570
39600 3.0" Mild Steel	7860	7170	6570	6050	5580	5170	4800	4470	4170
39640 4" Mild Steel	10460	9560	8760	8060	7440	6890	6400	5960	5560
39650 3.5" Mild Steel	9210	8410	7710	7090	6550	6060	5630	5240	4890
39800 3" 4130 Steel	7960	7270	6660	6130	5660	5240	4860	4530	4220
39850 3.5" 4130 Steel	9230	8430	7730	7110	6570	6080	5650	5260	4910
39860 4" DOM Mild Steel	10470	9560	8770	8070	7450	6900	6410	5970	5570
39880 3.5" Chromoly 1480	9320	8510	7800	7170	6620	6130	5690	5300	4940
39890 4" 1480 Bonded 7075	10620	9700	8890	8170	7540	6980	6480	6040	5630
39985 3.5" Bonded 6061	9050	8260	7580	6970	6430	5960	5530	5150	4810
39990 4" Bonded 6061	10460	9540	8750	8050	7430	6870	6380	5940	5540

Any rotating shaft will become dynamically unstable at certain speeds and create vibrations at an amplitude that will cause destruction. The shaft will go into a whirl or "jump rope" effect causing an imbalance that will vibrate violently and ultimately fail. In order to avoid these conditions all drivelines must operate within their critical speed limitations. The factors that determine the critical speed are the stiffness of the material, the diameter of the tubular member and the shaft length. Typically a larger diameter shaft has a higher critical speed than a smaller diameter shaft. The length of a shaft also has a great effect on its speed properties. The chart to the left shows general limits based on a 75% rating. Keeping shafts within these limits will assure smooth operation. Shafts operating higher than the speeds listed can expect vibration at some point.

**Critical Speeds of MW Driveshafts in RPM'S**  
*Lengths are centers of U-Joints*





## DRIVELINE COUPLERS

Mark Williams makes a complete line of driveline couplers for dragster, funny car, drag boat, pulling tractor, and other applications with solid mount rear ends that require direct connection or solid splined shafts. All couplers are made of 4140 alloy steel and hardened by MW's Austempering heat treat process. Gear cutting operations are performed on special fixtures that locate on the spline pitch diameters to assure minimum total indicated run out. Coupler seal and/or bushing diameters are CNC ground to a smooth finish to assure proper fit and sealing of lubricants. All couplers receive a protective black oxide finish for extra durability. Double splined solid driveshafts and the original MW quick disconnect Powerglide couplers are also available for applications where the distance from the transmission to the rear end is too long for a standard male/female coupler.



## TRANS COUPLERS, CONNECTORS & LOCK RINGS

### 40340 Ford C-4 Transmission Coupler

28 spline, male, Ford C-4 trans. 5-3/4" long

### 40350 Ford C-6 Transmission Coupler

31 spline, male, Ford C-6 trans. 5-3/4" long

### 40550 Mopar Transmission Coupler

30 spline, male, Jerico or Liberty trans. 5-3/4" long

### 40600 Lenco Transmission Coupler

16 spline, male, Lenco trans. 2-7/8" long

### 40601 Coupler Lock Ring (aluminum)

Fits 1 3/8" 16 or 32 spline trans output or splined shaft. 1 pc.

### 40602 Coupler Lock Ring (steel)

Fits 1 3/8" 16 or 32 spline trans output or splined shaft. 2 pc.

### 40603 Coupler Lock Ring (aluminum)

Fits 1 3/8" 16 or 32 spline trans output or splined shaft. 2 pc.

### 40605 Coupler Lock Ring (steel)

Fits 1 1/2" 35 spline trans output or splined shaft. 2 pc.

### 40610 Lenco Transmission Coupler

16 spline, male, Lenco trans. 3-7/8" long

### 40620 Lenco Transmission Coupler

16 spline, female, Lenco trans or 16 spline driveshaft.

### 40640 Lenco Transmission Coupler

32 spline, female, Lenco trans or 32 spline driveshaft.

### 40650 Male Coupler Ring Gear

20 tooth gear with 1.650 bore (for making special couplers).

### 40660 Lenco Transmission Coupler

35 spline, male, Lenco trans. 6" long

### 40700 Turbo 400 and B&J Trans Coupler

32 spline, male, Turbo 400 or B&J trans. 3-7/8" long

### 40711 Turbo 400 and B&J Trans Coupler

32 spline, male, Turbo 400 or B&J trans. 6-3/4" long

### 40780 Lenco Transmission Coupler

32 spline, male, Lenco trans. 3-7/8" long

### 40800 Powerglide Transmission Coupler

27 spline, male, Powerglide or 350 trans. 3-7/8" long

### 40805 Powerglide Transmission Coupler

27 spline, male for Dedenbear Tail Housing. 3-7/8" long

### 40810 Powerglide, Transmission Coupler

27 spline, male, Powerglide or 350 trans. 6 3/4" long

### 40820 Powerglide, Transmission Coupler

27 spline, male, Powerglide or 350 trans. 8" long

### 40900 Driveshaft Connector

16 spline, Lenco transmission and solid driveshafts.

### 40950 Driveshaft Connector

32 spline, Lenco transmission and solid driveshafts.

### 40951 Driveshaft Connector

32 spline, B & J transmission and solid driveshafts.

### 40960 Driveshaft Connector

35 spline, Lenco transmission and solid driveshafts.

## PINION COUPLERS

### 40000 9" Ford Pinion Coupler

35 spline, female, 9" Ford large pinion.

### 40040 9" Ford Pinion Coupler

40 spline, female, 9" Ford TF pinion.

### 40045 11" Modular Pinion Coupler

40 spline, female, 11" Modular pinion.

### 40050 Blank Female Pinion Coupler

No internal splines, No heat treat

### 40060 9" Ford Pinion Coupler

32 Spline, female, Low Friction Thirdmember

### 40100 9" Ford Pinion Coupler

35 spline, male, 9" Ford large pinion.

### 40200 '49-'50 Olds-Pontiac Pinion Coupler

10 spline, female.

### 40250 '57-'64 Olds-Pontiac Pinion Coupler

13 spline, female.

### 40300 9" Ford Pinion Coupler

28 spline, female, 9" Ford standard pinion.

### 40400 Dana 60 Pinion Coupler

29 spline, female.

### 40500 8-3/4" Mopar Pinion Coupler

10 spline, female.

### 40630 Quick Change Pinion Coupler

10 spline, female.

### 40750 12-Bolt Chevrolet Pinion Coupler

30 spline, female.

### 49300 9" Ford Aluminum Pinion Coupler

Made from 7075 Aluminum. Similar to 40300. 28 Spline, female. 9" Ford standard pinion. **Note: Limited service life.**

# SOLID DRIVESHAFTS

MW solid driveshafts are for vehicles with solid mounted rear ends where a single coupler is not long enough. These shafts are available in stocked lengths from 6" to 28" long. All shafts are machined out of 4340-alloy steel. All shafts are, micro polished, and heat-treated with MW's austempering process. All shafts receive a black oxide finish. Standard shafts in stock are: 1-3/8-16 straight key, 1-3/8-32 involute spline and 1-1/2-35 involute splines. Shafts over 12" have 4 full inches of spline on each end and can be shortened up to 2" on each end. Couplers and spline shafts should not be used unless perfect alignment is assured. Critical speed calculations must be considered for these shafts. Call with your numbers to confirm the RPM critical speed value. MW can also build custom solid driveshafts to your specs with different splines upon request.

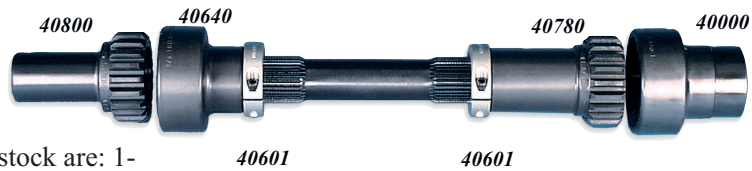

Typical Powerglide to 9" Ford set-up with 32 spline shaft

## 16 SPLINE DRIVESHAFTS

- 41000-06 F/C Driveshaft, 16 Spline 6" Long
- 41000-08 F/C Driveshaft, 16 Spline 8" Long
- 41000-12 F/C Driveshaft, 16 Spline 12" Long
- 41000-14 F/C Driveshaft, 16 Spline 14" Long
- 41000-16 F/C Driveshaft, 16 Spline 16" Long

- 41000-20 F/C Driveshaft, 16 Spline 20" Long
- 41100-24 F/C Driveshaft, 16 Spline 24" Long
- 41100-28 F/C Driveshaft, 16 Spline 28" Long
- 41100-32 F/C Driveshaft, 16 Spline 32" Long

## 32 SPLINE DRIVESHAFTS

- 41050-06 F/C Driveshaft, 32 Spline 6" Long
- 41050-08 F/C Driveshaft, 32 Spline 8" Long
- 41050-12 F/C Driveshaft, 32 Spline 12" Long
- 41050-16 F/C Driveshaft, 32 Spline 16" Long

- 41050-20 F/C Driveshaft, 32 Spline 20" Long
- 41150-24 F/C Driveshaft, 32 Spline 24" Long
- 41150-28 F/C Driveshaft, 32 Spline 28" Long

## 35 SPLINE DRIVESHAFTS

- 41060-06 F/C Driveshaft, 35 Spline 6" Long
- 41060-24 F/C Driveshaft, 35 Spline 24" Long

- 41160-28 F/C Driveshaft, 35 Spline 28" Long
- 41160-32 F/C Driveshaft, 35 Spline 32" Long

## QUICK DISCONNECT POWERGLIDE COUPLER

This innovative MW original design allows transmission removal without disturbing the engine or rear end. Perfect for Comp and Super Comp dragsters. **Shorty Powerglide only.**

### POWERGLIDE 27 SPLINE BUSHING TAIL HOUSINGS

- 40830 Q/D Coupler, Powerglide (Short)  
*Requires 4" from trans seal to pinion coupler, bushed housing*
- 40840 Q/D Coupler, Powerglide (Long)  
*Requires 4" - 6" from trans seal to pinion coupler, bushed housing*
- 40860 Q/D Coupler, Powerglide (Extra Long)  
*Requires 6"-8" from trans seal to pinion coupler, bushed housing*

### POWERGLIDE 27 SPLINE ROLLER TAIL HOUSINGS

- 40850 Q/D Coupler, Powerglide (Short)  
*Requires 4" from trans seal to pinion coupler, roller housing*
- 40855 Q/D Coupler, Powerglide (Long)  
*Requires 4"-6" from trans seal to pinion coupler, roller housing*
- 40865 Q/D Coupler, Powerglide (Extra Long)  
*Requires 6"-8" from trans seal to pinion coupler, roller housing*

Individual replacement parts are available for all couplers. Our MW Technical Representative can help you find the right parts. Give us a call.

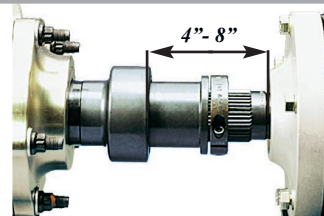

With coupler installed and lock ring in place, a gap (approximately 1/8") is needed to be between lock ring and coupler to avoid binding as the chassis works.

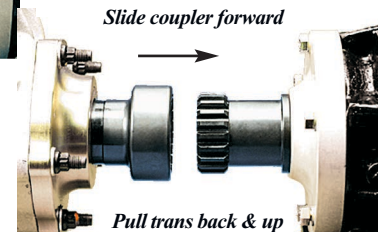

When removing the transmission, remove the lock ring and slide coupler forward to the back of the transmission. This allows the transmission to be moved back and off the dowel pins of the engine.

### POWERGLIDE WITH 32 SPLINE OUTPUT

- 40870 Q/D Coupler 32T for Powerglide (Short)  
*Requires 4" from trans seal to pinion coupler, roller housing*
- 40875 Q/D Coupler 32T Powerglide (Long)  
*Requires 4"-6" from trans seal to pinion coupler, roller housing*
- 40876 Q/D Coupler 32T, Powerglide (Extra Long)  
*Requires 6"-8" from trans seal to pinion coupler, roller housing*
- 40878 Q/D Coupler 32T, T-400 (Extra Long)  
*Requires 6"-8" for Bushing (long barrel)*



## QUICK RELEASE STEERING HUBS

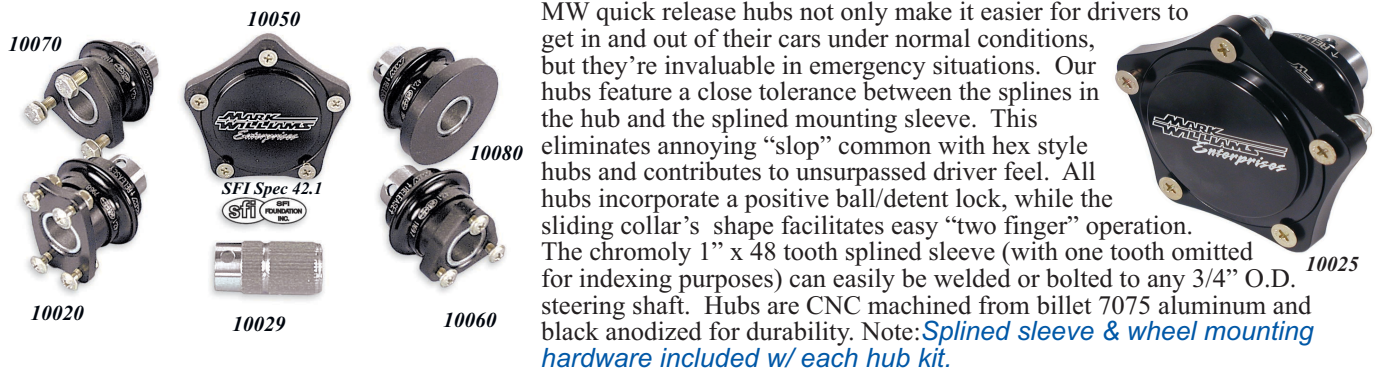

MW quick release hubs not only make it easier for drivers to get in and out of their cars under normal conditions, but they're invaluable in emergency situations. Our hubs feature a close tolerance between the splines in the hub and the splined mounting sleeve. This eliminates annoying "slop" common with hex style hubs and contributes to unsurpassed driver feel. All hubs incorporate a positive ball/detent lock, while the sliding collar's shape facilitates easy "two finger" operation. The chromoly 1" x 48 tooth splined sleeve (with one tooth omitted for indexing purposes) can easily be welded or bolted to any 3/4" O.D. steering shaft. Hubs are CNC machined from billet 7075 aluminum and black anodized for durability. Note: *Splined sleeve & wheel mounting hardware included w/ each hub kit.*

**10020** Q/R Hub Dragster & F/C  
*For MW wheels, 4 holes, 3/16" holes, .75 x 1.65*

**10025** Q/R Hub  
*5-Hole Grant GT Pattern, 3/16" hole, 5 x 2.86 B.C.*

**10029** Splined Sleeve, Bolt on

**10050** Q/R Hub  
*6-Hole Sparco/Momo Pattern. 3/16" holes, 2.755" (70mm) B.C*

**10060** Q/R Steering Hub  
*3 hole Don Long style, 10-32 thd., 3 holes on 1.375 B.C.*

**10070** Q/R Hub  
*Oval track, 3 hole x 1/4" threads on 1.75 B.C.*

**10080** Q/R Hub, Universal  
*Blank 2.45" diameter flange.*

**30112** 1/4" Cross Bolt and Nut  
*Aircraft smooth shank bolt with washers and Jet nut.*

## DRAGSTER STEERING WHEELS

MW Dragster/FC steering wheels are fully CNC machined from 3/16" aluminum. Main wheel is fully polished inside and out with your choice of anodized or polished grips. MW wheels are approximately 7 5/8" wide and 7 1/8" deep and drilled to match steering hub #10020 or D5 mount. *Switch panel mounting holes must be drilled in steering wheels*

**10035** Dragster/FC Type Steering Wheel  
*With polished, red, blue, black or gold anodized aluminum grips installed. Mounting drilled for 10020 quick release hub or D5 weld in mount. All colors same price*

**10045** Switch Polished Panel  
*Polished Aluminum (no holes)*

**10046** Switch Panel  
*Brushed Aluminum, w/ Button Holes*

**10047** Switch Black Panel  
*Black Aluminum (no holes)*

**10048** Switch Black Panel



Black

**10048** (Holes)  
*Aluminum, with Button Holes*

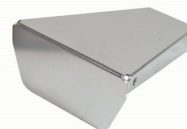

**10045** (PLAIN)

**10035** Blue

**10035 & 10048**  
*(Switches not Included)*

## STEERING WHEELS

**713-4** 10" Grant "D" Shape Steering Wheel  
*Black suede grip, silver spokes. Uses 10060 quick release hub. Dragster/Altered applications. Not legal for door cars.*

**763-1** 13" Grant Steering Wheel  
*Black grip, silver spokes. Uses 10025 quick release hub.*

**764-1** 13" Grant Steering Wheel  
*Black grip, yellow stripe, silver spokes. Uses 10025 quick release hub.*

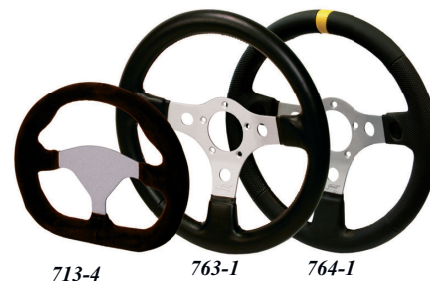

713-4

763-1

764-1

## STEERING BOXES

MW stocks a billet Funny Car type steering box for front-engine applications and rack and pinion steering boxes for rear engine dragsters. Racks are available in 10" or 15" widths and with racks in either steel or aluminum. Rack and Pinion Units are dimensionally the same as original P&S machine steering

### 30100 Rack and Pinion

15" rack with 6" of travel steel rack 2.74 lbs

### 30100A Aluminum Rack and Pinion

15" 7075 aluminum rack with 6" of travel 1.71 lbs

### 30200 Standard Steering, 10:1 Ratio

Standard unit for F/C and Altered race cars 5.36 lbs

### 30400A Aluminum Rack and Pinion

10" 7075 aluminum rack with 6" of travel 1.34 lbs

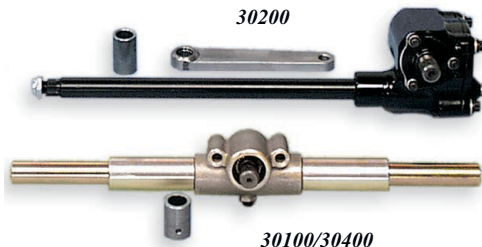

## MW FRONT SPINDLES

MW front spindles are manufactured from 4130 steel forgings or 7075 Aluminum Billet and accept the popular Anglia style spindle mount wheels. All spindles are drilled top and bottom for a steering arm or a tow hook attachment and are black oxidized. Steering arms are profile milled from 1/4" 4130 steel or 1/4" 7075 aluminum. All assemblies include brass thrust washers, spindle castle nuts, washers, and cotter pins.

### 31200 MW Front Spindle Assembly (pr)

Steel. 2 control arms. Standard is 5" arms

### 31210 MW Front Spindle Assembly (pr)

Steel 3 control arms. Specify 4", 5" or 6" arms.

### 31230 MW Front Spindle Assembly (pr)

Steel With king pins. No steering arms.

### 31300 Aluminum 7075 Spindle (pr)

Two 4" aluminum arms with castle nuts and thrust washers.



## TUBULAR FRONT AXLES

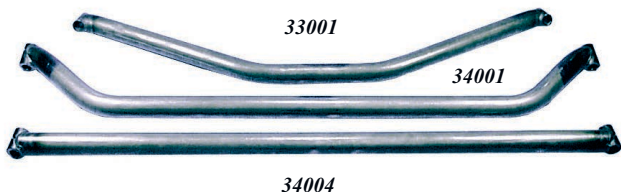

### 33001 Dragster Axle

6" drop, 39" centers, 6" flat, 1-1/2 x .120 4130 tube

### 33002 Dragster Axle

5" drop, 39" centers, 6" flat, 1-1/2 x .120 4130 tube

### 33003 Dragster Axle

5" drop, 39" centers, 20" flat, 1-1/2 x .120 4130 tube

Mark Williams tubular front axles are built from 4130N chromoly tubing. King pin bosses are TIG welded using a special precision fixture to maintain correct king pin angle then king pin bores are reamed after final welding.

### 33005 Dragster Axle

6" drop, 36" centers, 6" flat, 1-1/2 x .120 4130 tube

### 34001 Funny Car/Altered Axle

5" drop, 42" centers, 1-5/8 x .188 4130 tube

### 34002 Funny Car/Altered Axle

3" drop, 40" centers, 1-5/8 x .188 4130 tube

### 34004 Funny Car/Altered Axle

40" centers straight, 1-5/8 x .188 4130 tube

## A-ARM FRONT END MATERIALS KITS

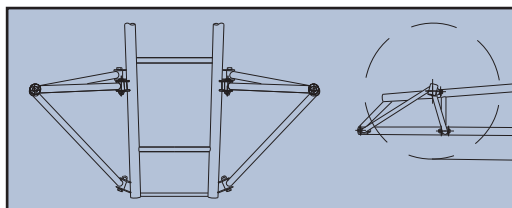

Typical Dragster A arm installation

The advantages of an A-arm setup include lighter weight, increased rigidity, and contemporary styling. Both kits feature a bolt on removable A-arm design. The 33600 A-arm jig fixture of similar fixture is necessary build with these kits.(Page 83)

### 34500 F/C Altered A-Arm Front End Kit

### 33500 Dragster A-Arm Front End Kit

### 33600 A-Arm Jig Fixture (see photo page 83)

# TORSION ASSEMBLIES

## FUNNY CAR TORSION ASSEMBLY

The MW FC/Altered torsion bar assembly is designed for use on either a Funny Car or Altered chassis, and has a 26" span with 5 inch arms. The housing is 1-1/2" x .065 diameter 4130 chromoly tubing, while the torsion bar is heat-treated 4140 steel.

Extra fine adjustments are possible through the use of 7/8"-48-spline serrations on the torsion bar and arms. The torsion arm load is carried by Torrington® needle bearings. Plus complete freedom of axle movement is assured through the use of 3/8" spherical bearings swedged in the torsion arms.



**35000** Funny Car/Altered Torsion Assembly  
26" centers with 5" arms

## AXLE MOUNTING BRACKETS



15010

Pre-cut mounting brackets make it easy to mount the front axle. All are produced from 4130 sheet normalized condition steel.



33020

**15010** Axle Mount Brackets F/C (4)  
3/16 4130 welds to 1-5/8" tube axle bolts to the 35000 Torsion

**33020** Axle Mount Brackets Dragster (4)  
3/16 4130 plate welds to 1-1/2" tube axle, bolts to the 35300 Torsion

## DRAGSTER TORSION ASSEMBLY

Mark Williams has reproduced the Dragster Torsion assembly that was used in the '60's. The bar is produced from 1/2" hex material and has 7/8-48 serrated buttons on the ends for height adjustment. The splined button is hardened as well as the end flange in the tube, to retard wear a small grease hole allows lubrication of the moving parts. This is the same dimensionally, as was used for Woody Gilmore and Mark Williams front engine cars.



35300

**35300** Dragster Torsion Bar  
20" centers 6-3/8" long arm 1-3/8" Dia housing

# ANTI-ROLL ASSEMBLIES

The Anti-Roll assembly features splined 7075 aluminum outer arms. There are two models, 1-1/4" and 1-1/2" spline sizes. The shaft for the 1-1/4" (351XX) series can be heavy wall 1-1/4" chromoly tube or splined adapter .083" diameter adapter tube. The 1-1/2" spline size assemblies, (352XX) series utilize the splined adapter for for 3" x .083 wall 4130 tube.

The splined arms eliminate the possibility of oblong holes which are typical of a thru bolt design. The arms have a clevis design and accept 3/8" rod ends. The 3" tubular bar is stiffer than the straight 1-1/4" bar, and has the advantage of being fabricated to any width in the field.

The spherical self-aligning aluminum and Delrin® bearing mount are supplied with the weld on tabs and are available separately.

## 1-1/4" ANTI-ROLL ASSEMBLIES

**35105** 3" Tubular Anti Roll Center Tube Assy. 1-1/4"  
3" center tube assy., with 35103 bearings, specify 5" or 6" arms & width.  
Includes (2) 35103 bearing blocks.

**35100** MW Anti-Roll Assembly 1-1/4" Serrations  
5" or 6" arms. 18" centers. 1-1/4 x .188 tube (custom widths available)  
(no bearing blocks)

**35103** Spherical Bearing Block 1-1/4"  
1-1/4" x 48 Tooth serrations partially in bore. (2 required)

## 1-1/2" ANTI-ROLL ASSEMBLIES

**35250** 3" Tubular Anti Roll Center Tube Assy 1-1/2"  
3 X .083" X (24") center tube 35203 bearings (2), 1.5" ends, and 6" aluminum arms

**35203** Spherical Bearing Block, 1-1/2" (one)  
1-1/2" x 48 Tooth serrations partially in bore. (2 required)  
and 35105 kits (not shown).

**35110** Linkage Kit for Anti-Roll Assembly  
Includes (2) 12" long 7/8"x .058" tube, tube adapters 4130 7/16" large shank RH & LH rod ends with 3/8" holes, all nuts and washers, for 35100



35100

35105

35103

35250

35203

# SUSPENSION, MONO-SHOCK ROCKER SYSTEM

This is a unique mono-shock system that's perfect 4-link dragster. This design utilizes a single coil over shock and combines the functions of actuating the shock and an anti-roll bar in one assembly. 12010 assembly as shown is with optional shock and spring, which are sold separately. Three different spring rates are available to suit various engine combinations.



12010 Rocker Assembly shown with available coil over

12010	Rocker Suspension Assembly (less shock)
12011	Splined Outer Rocker Arm (ea)
12017	Delrin® Shaft Bushing (ea)
12015	Adjuster Link, no rod ends (ea)
12019	Double Adjustable Shock (5" stroke no spring)
12019-225	Coil Spring (225#)
12019-275	Coil Spring (275#)
12019-400	Coil Spring (400#)

## 4-LINK & WISHBONE KITS



12020	Dragster/Altered 4 Link Kit <i>Kit uses 1-1/8" x .083" tubing &amp; 5/8" x 5/8" rod ends.</i>
12021	Dragster Front 4 Link Bracket (ea)
12030	Dragster/Altered Wishbone Kit (ea) <i>1/2" (2) and 5/8" (1) 4130 rod ends, aluminum slider shaft</i>
97100	4 Link Kit for 96000/97000 Housing <i>Kit uses 1-1/4" x .095 tubing &amp; 5/8 x 3/4 rod ends.</i>
97150	Front Chassis 4 Link Bracket (ea)

Mark Williams' 4-link wishbone kits include everything required to complete a standard 4-link rear suspension from the chassis to the housing. All kits include Aurora 4130 rod ends, jam nuts, tube adapters, M/W reduced hex shear shank bolts and locking jam nuts, and chromoly tubing. Both 4-link kits also include chromoly front chassis brackets.

## LEVERS, PEDALS

MW brake levers and clutch/brake pedal are all CNC machined from 1/4" 6061 aluminum stock and fully polished to a bright luster. Both brake levers have anodized aluminum grips installed (red, blue, black, gold, or polished). Clutch/brake pedal features bolt-on foot pad with grooved non-slip surface. All include mounting stud #10040 (see below).

10042	Brake/Clutch Pedal <i>With bolt on foot pad.</i>
10043	Dragster Brake Lever <i>Specify color of aluminum grips.</i>
10044	Funny Car Brake Lever <i>Specify color of anodized aluminum grips.</i>



## LEVER/PEDAL MOUNTING STUD

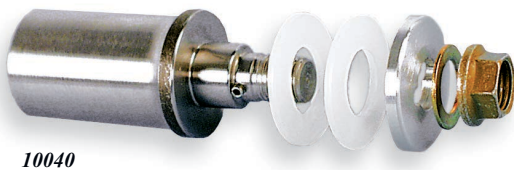

10040

This unique assembly makes mounting controls such as brake levers and/or pedals simple. The use of a keyed aluminum washer along with teflon washers on each side of the lever allows the tension to be adjusted without the possibility of the nut loosening during use. The main body is machined from 4130 alloy steel and can be cut to fit against chassis rail (as shown).

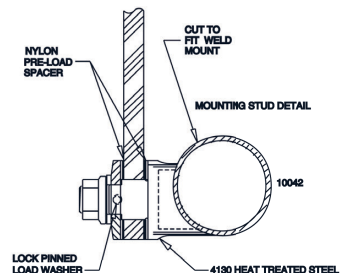

10040 Lever/Pedal Mounting Stud Assembly



# MORSE CONTROL CABLES

33C-3 3' Morse Push/Pull Cable
33C-4 4' Morse Push/Pull Cable
33C-5 5' Morse Push/Pull Cable
33C-6 6' Morse Push/Pull Cable
33C-7 7' Morse Push/Pull Cable
33C-8 8' Morse Push/Pull Cable
33C-9 9' Morse Push/Pull Cable
33C-10 10' Morse Push/Pull Cable
33C-11 11' Morse Push/Pull Cable
33C-12 12' Morse Push/Pull Cable
33C-13 13' Morse Push/Pull Cable
33C-14 14' Morse Push/Pull Cable
33C-24 24' Morse Push/Pull Cable

## CABLE ACCESSORIES

A-21002 Quick Cable End 1/4"-28 X 3/8 Ball
A-29104 Quick Release Rod End, 1/4-28 thread
A-31799 Quick Release Rod End, 10-32 thread
A-31800 Clevis, 10-32 thread
A-31804 Clamp & Shim



MW recommends the use of chromoly rod ends in high stress applications such as suspension components and steering linkage. All of the Aurora® 4130 chromoly rod ends listed here are a 3 piece design.

AM6 3/8-24" 4130 Male Rod End
AB6 3/8-24" 4130 Male Left Hand Rod End
AM7 7/16"-20 4130 Male Rod End
AB7 7/16"-20 4130 Male Left Hand Rod End
AM8 1/2"-20 4130 Male Rod End
AB8 1/2"-20 4130 Male Left Hand Rod End
AM10 5/8"-18 4130 Male Rod End
AB10 5/8"-18 4130 Male Left Hand Rod End
AM12 3/4"-16 4130 Male Rod End
AB12 3/4"-16 4130 Male Left Hand Rod End
RAM6T 3/8"-24 4130 Rod End <i>Right hand thread, nickel plated and PTFE lined.</i>

Morse control cables have been the standard for many years and are ideal for operating your throttle, fuel shut-off, shifter/reverser, or chute release. MW stocks 3 foot to 14 foot cables and most of the common end fittings and clamps, both standard and quick release.

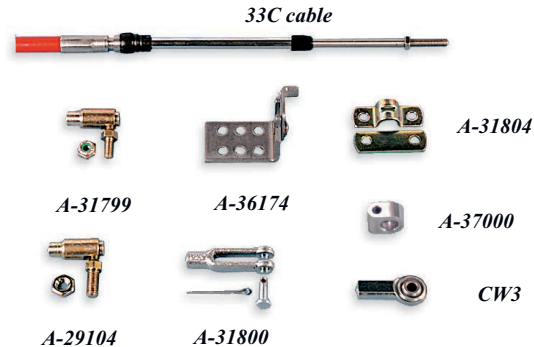

A-36174 Quick Release Clamp
A-37000 Clamp, Aluminum Morse Cable
CW3 3/16" Female Rod End .

## CHROMOLY ROD ENDS

RXAM10T 3/4"-16 4130 Male Rod End <i>5/8" ball, right hand thread, nickel plated and PTFE lined.</i>
RXAB10T 3/4"-16 4130 Male Rod End <i>5/8" ball, left hand thread, nickel plated and PTFE lined.</i>
RAM12T 3/4"-16 4130 Male Rod End <i>Right hand thread, nickel plated and PTFE lined.</i>
RAB12T 3/4"-16 4130 Male Rod End <i>Left hand thread, nickel plated and PTFE lined.</i>
XAM6 7/16"-20 4130 Male Rod End <i>3/8 ball, right hand thread.</i>
XAB6 7/16"-20 4130 Male Rod End <i>3/8 ball, left hand thread.</i>
XAM10 3/4"-16 4130 Male Rod End <i>5/8 ball, right hand thread.</i>
XAB10 3/4"-16 4130 Male Rod End <i>5/8 ball, left hand thread. 5/8 ball, left hand thread.</i>
RXAM-8T-3 3/4"-16 4130 Male Rod End <i>3/4 Shank, Teflon Lined. 1/2" ball, right hand thread.</i>
RXAB-8T-3 3/4"-16 4130 Male Rod End <i>3/4 Shank, Teflon Lined. 1/2" ball, left hand thread.</i>

## THIN JAM-NUTS

Jam nuts are used to lock the rod end in the mating female threaded connector. We can supply thin steel nuts of aircraft quality or M/W produced from 7075 aluminum and gold coated. Currently the 3/4 and 1/2" sizes are available in aluminum with more to follow.

N5R 5/16-24 R.H. Jam Nuts, (6 pcs)
N5L 5/16-24 L.H. Jam Nuts, (6 pcs)
N6R 3/8-24 R.H. Jam Nuts, (6 pcs)
N6L 3/8-24 L.H. Jam Nuts, (6 pcs)
N7R 7/16-20 R.H. Jam Nuts, (6 pcs)
N7L 7/16-20 L.H. Jam Nuts, (6 pcs)
N8R 1/2-20 R.H. Jam Nuts, (6 pcs)
N10R 5/8-18 R.H. Jam Nuts, (4 pcs)
N10L 5/8-18 L.H. Jam Nuts, (4 pcs)
N8RA 1/2-20 R.H. Aluminum Jam Nuts, (6 pcs)
N8LA 1/2-20 L.H. Aluminum Jam Nuts, (6 pcs)
N12RA 3/4-16 R.H. Aluminum Jam Nuts, (4 pcs)
N12LA 3/4-16 L.H. Aluminum Jam Nuts, (4 pcs)

## MILD STEEL ROD ENDS

CM3	10-32 Male Rod End
CW3	10-32 Female Rod End
CW4	1/4"-28 Female Rod End
CM5	5/16"-24 Male Rod End
CB5	5/16"-24 Left Hand Male Rod End
CW5	5/16"-24 Female Rod End
CM6	3/8"-24 Male Rod End
CB6	3/8"-24 Male Left Hand Rod End
CM7	7/16"-20 Male Rod End
CB7	7/16"-20 Male Left Hand Rod End
CM8	1/2"-20 Male Rod End
CB8	1/2"-20 Male Left Hand Rod End

Mark Williams Enterprises stocks a complete line of mild steel Aurora® spherical rod ends. The mild steel rod ends listed here are a 2 piece design and are ideal for applications such as throttle, shifter, clutch linkage, and other light duty applications.



CM10	5/8"-18 Male Rod End
CB10	5/8"-18 Male Left Hand Rod End
CM12	3/4"-16 Male Rod End
CB12	3/4"-16 Male Left Hand Rod End
XM10	3/4"-16 Male Rod End <i>3/4-16 Thread on shank with 5/8" hole in ball.</i>
XB10	3/4"-16 Male Left Hand Rod End <i>3/4-16 Thread on shank with 5/8" hole in ball.</i>

## TUBE ADAPTERS & CLEVISES

MW weld in tube adapters make fabricating linkage, struts, or any application that requires joining a male rod end or threaded clevis to chromoly tubing a snap. All MW tube adapters are CNC machined and lead screw tapped to ensure a precise and square

10510	Tube Adapter, 5/16"-24 to 5/8 x .058
10510L	Tube Adapter, 5/16"-24 L.H. to 5/8 x .058
10610	Tube Adapter, 3/8"-24 to 5/8 x .058
10610L	Tube Adapter, 3/8"-24 L.H. to 5/8 x .058
10612	Tube Adapter, 3/8"-24 to 3/4 x .058
10612L	Tube Adapter, 3/8"-24 L.H. to 3/4 x .058
10614	Tube Adapter, 3/8"-24 to 7/8 x .058
10614L	Tube Adapter, 3/8"-24 L.H. to 7/8 x .058
10714	Tube Adapter, 7/16"-20 to 7/8 x .058
10714L	Tube Adapter, 7/16"-20 L.H. to 7/8 x .058
10814	Tube Adapter, 1/2"-20 to 7/8 x .058
10814L	Tube Adapter, 1/2"-20 L.H. to 7/8 x .058
10816	Tube Adapter, 1/2"-20 to 1 x .058
10816L	Tube Adapter, 1/2"-20 L.H. to 1 x .058
11016	Tube Adapter, 5/8"-18 to 1 x .058
11016L	Tube Adapter, 5/8"-18 L.H. to 1 x .058
11018	Tube Adapter, 5/8"-18 to 1 1/8 x .083



11018L	Tube Adapter, 5/8"-18 L.H. to 1 1/8 x .083
11218	Tube Adapter, 3/4"-16 to 1 1/8 x .083
11218L	Tube Adapter, 3/4"-16 L.H. to 1 1/8 x .083
11220	Tube Adapter, 3/4"-16 to 1 1/4 x .058
11220L	Tube Adapter, 3/4"-16 L.H. to 1 1/4 .058
11221	Tube Adapter, 3/4"-16 Thread <i>For 1-1/4 x .095 tubing, for 4-link rear suspension</i>
11221L	Tube Adapter, 3/4"-16 L.H. Thread <i>For 1-1/4 x .095 tubing, hex wrench driver for 4-link</i>

## WELD-IN CLEVISES

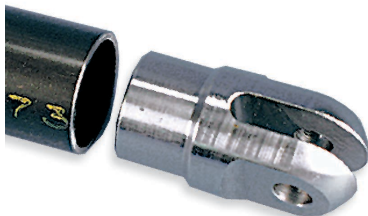

20316

MW weld-in clevises are manufactured in-house from 4130 steel on CNC machinery. All are designed with a step down diameter for a precise fit in the chromoly tubing listed. MW weld-in clevises work great for wing struts, wheelie bars etc. See page 81 for tabs that can be used.

20210	5/8" Weld Clevis <i>Fits 5/8" x .058" tubing and 1/8" thick bracket. 1/4" hole.</i>
20312	3/4" Weld Clevis <i>Fits 3/4" x .058" tubing and 3/16" thick bracket. 5/16" hole.</i>
20314	7/8" Weld Clevis <i>Fits 7/8" x .058" tubing and 3/16" thick bracket. 5/16" hole.</i>
20316	1" Weld Clevis <i>Fits 1" x .058" tubing and 3/16" thick bracket. 5/16" hole.</i>
20416	1" Weld Clevis <i>Fits 1" x .058" tubing and 1/4" thick bracket. 5/16" hole.</i>





## CHASSIS BRACKETS & TABS

All of the MW brackets and tabs listed below are manufactured from 1/8" thick 4130N chromoly steel, except for 10010 and 15010 which are 3/16" thick and D5 which is 1/16" thick chromoly.

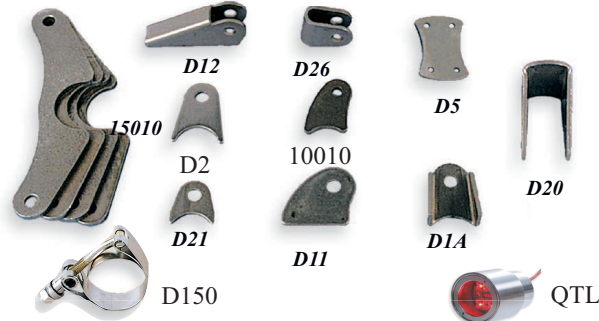

**CALL FOR BULK PRICING ON CHASSIS TABS**

- 10010 Mounting Tab for Clevis (5/16" hole)
- 15010 Torsion Mounting Brackets, 3/16" (set of 4)  
*For 34002 3" drop x 40" centers*
- D11 Anti-Rotation Tab (3/8" Hole)
- D12 Chassis Radius Rod Mount Bracket
- D1A Small Motor Mount Tab (3/8" Hole)
- D2 Large Flat Mount Tab (3/8" Hole)
- D20 Large Motor Mount Tab (No hole)
- D21 Small Flat Mounting Tab (3/8" Hole)
- D26 Weld-In Clevis for 7/8" Tube (3/8 Rod End)
- D5 Steering Wheel Mount Plate
- D150 Motor Mount Clamp, 1-1/2" (ea)  
*Fits 1-1/4" to 1-1/2" diameter tubing. Quantity pricing available.*
- QTL Frame Rail Tail Light

- D30 Dzus Mounting Tab, (ea)
- D30-100 Dzus Mount Tabs, (pack of 100)
- D30L Dzus Mounting Tab, 3" Long (ea)
- D30L-100 Dzus Mounting Tab, 3" Long (100)
- D40 Dzus Buttons, Steel (10 ea.)
- D40-100 Dzus Buttons, (pack of 100)
- D50 Dzus Springs, (pack of 10)
- D50-100 Dzus Springs, (pack of 100)
- D70 Panel Doubler (Round)
- D100 Dzus Button Wrench
- D200 Dzus Dimpling Tool

## DZUS FASTENERS & TOOLS

Dzus fasteners are the most widely accepted method of securely attaching aluminum body panels, fiberglass panels, seats, etc. MW stocks the popular buttons, springs, tabs, and panel doublers along with the proper dimpling, and installation tools, and button wrench.

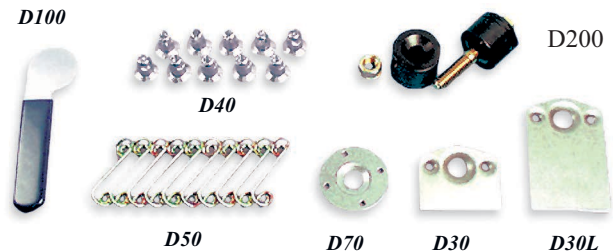

## ENGINE MOUNTING PLATES

All MW engine mounting plates are manufactured from 1/4" thick 7075-T6 aluminum plate and CNC machined with common crankshaft centerlines to ensure exact fit and interchange-ability even from one engine make to another. Semi-Finished plate Has the 6" crankshaft hole, dowel pin, and 2" vent holes.

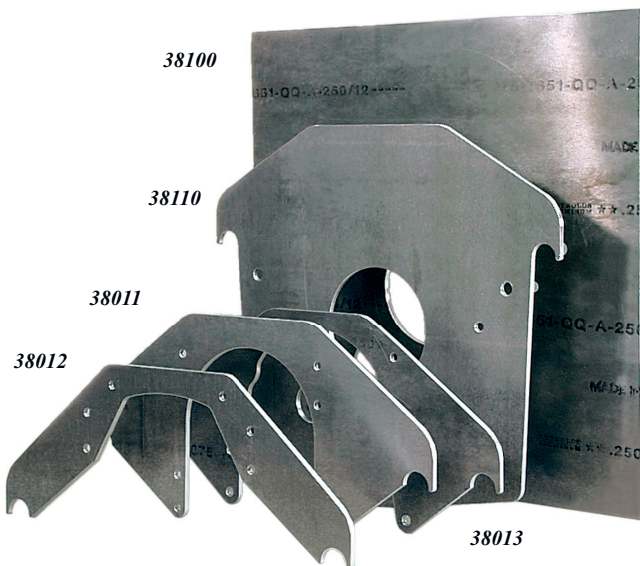

- 38010 Engine Mount Plate Blank  
*12" x 24" Front blank. 1/4" thick (no holes)*
- 38100 Rear Engine Mount Plate  
*24" x 24" Semi-Finished with crank and vent holes and choice of dowel pin holes. 1/4" thick.*
- 38115 Rear Engine Mount Plate  
*For Funny Car and Altered with crank and vent holes. Milled for 1 1/2" tube size. Choice of dowel pin holes. Top section is not profiled. 1/4" thick. (photo not shown)*
- 38110 Rear Engine Mount Plate  
*For Dragster with crank and vent holes. Milled for 1 1/4" tube size. Choice of dowel pin holes. 1/4" thick.*
- 38011 Front Engine Mount Plate  
*Small Block Chevrolet for Dragster & Funny Car. 1/4" thick.*
- 38012 Front Engine Mount Plate  
*Late Model Chrysler for Dragster and Funny Car. 1/4" thick.*
- 38013 Front Engine Mount Plate  
*Big Block Chevrolet for Dragster & Funny Car. 1/4" thick.*

# CHROMOLY TUBING & PLATE

All MW 4130 tubing is certified aircraft quality material that meets 6736 specifications. Small quantities of under a 100' are sold at the cut price. Large quantities of 100' or more are sold at the 100' price. Different tubing sizes can be combined to produce an order of more than 100' but they must be full lengths. Full lengths can be anywhere from 17' - 24'.

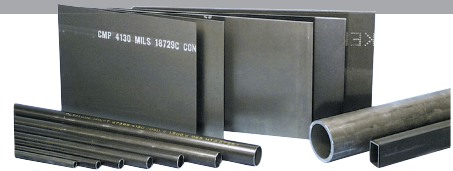

PART#	DESCRIPTION	LBS./FT	CUT	100'
0375x058	3/8 x .058 Tube	.20	10.83	8.13
0500X058	1/2 x .058 Tube	.27	12.09	9.07
0625X058	5/8 x.058 Tube	.35	7.35	5.52
0750X058	3/4 x.058 Tube	.43	10.20	7.65
0875X058	7/8 x .058 Tube	.51	9.20	6.90
1000X058	1 X .058 Tube	.58	9.58	7.19
1125X058	1 1/8 x .058 Tube	.66	11.25	8.44
1125X083	1 1/8 x .083 Tube	.92	13.86	10.40
1250X058	1 1/4 x .058 Tube	.74	10.65	7.99
1250X083	1 1/4 x .083 Tube	1.03	14.46	10.85
1250X095	1 1/4 x .095 Tube	1.17	16.38	12.23
1375X058	1 3/8 x .058 Tube	.82	13.05	9.78
1375X065	1 3/8 x .065 Tube	.91	14.43	10.83
1375X095	1 3/8 x .095 Tube	1.30	18.36	13.77
1500X058	1 1/2 x .058 Tube	.89	11.16	8.37
1500X065	1 1/2 x .065 Tube	1.00	9.78	7.34
1500X120	1 1/2 x .120 Tube	1.77	20.97	15.73
1625X083	1 5/8 x .083 Tube	1.37	15.243	11.43
1625X188	1 5/8 x .188 Tube	2.88	34.80	26.10
3000X250	3 x .250 Tube	7.34	63.57	
3250X250	3 1/4 x .250 Tube	8.01	74.52	
4130-062	Sheet Steel, 4130 1/16" Thick 9" X 12"			.2178
4130-125	Sheet Steel, 4130 1/8" Thick 9" x 18"			.58.10
4130-187	Sheet Steel, 4130 3/16" Thick 9" x 18"			.74.34
4130-250	Sheet Steel, 4130 1/4" Thick 9" X 18"			.91.10

## PRE-BENT CHROMOLY TUBING

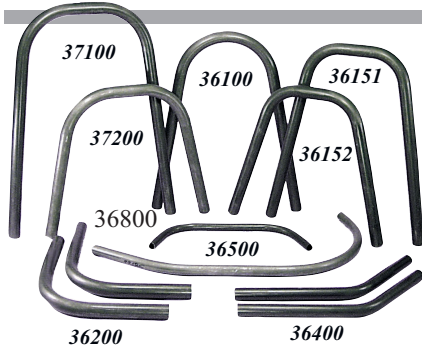

MW's stock of pre bent tubing includes, roll bars, shoulder hoops, dragster frame rails etc. These items are all mandrel bent in-house and designed for the professional or the do-it-yourself chassis builder.

12041	Driveshaft Loop (2 pcs) 7/8 x .058 4130 tube. 180° bends. 5" wide inside.
36050	1 5/8" Dragster Bend Package Roll bar, secondary roll bar, back braces and shoulder hoop.
36060	1 1/2" Dragster Bend Package Roll bar, secondary roll bar, back braces and shoulder hoop.
36100	Dragster Roll Bar (single bend) 24" tall x 19 1/2" centers, 1-5/8 x .083 4130 tube.
36151	Double Bend Dragster Roll Bar 24" tall x 19 1/2" centers, 1-5/8 x .083 4130 tube, 2 bends.
36152	Double Bend Drag Secondary Roll Bar 19" tall x 19 1/2" centers 1-5/8 x .083 4130 tube, 2 bends.
36155	Helmet Guard Tubes (pr) 1 x .058 4130 tube, 2 bends. Now mandatory.
36161	Double Bend Dragster Roll Bar 24" tall x 19 1/2" centers, 1-1/2 x .065 4130 tube, 2 bends.
36162	Double Bend Drag Secondary Roll Bar 19" tall 19 1/2" centers 1-1/2 x .065 4130 tube, 2 bends.
36171	Double Bend Dragster Roll Bar (6" radius) 24" tall x 19 1/2" centers, 1-1/2 x .065 4130 tube, 2 bends.
36172	Double Bend Drag Sec. Roll Bar (6" radius) 19" tall 19 1/2" centers 1-1/2 x .065 4130 tube, 2 bends.
36200	Dragster Roll Bar Back Brace 14" tall x 16" deep, 90 degree bend, 1 5/8 x .083 4130 tube.
36260	Dragster Roll Bar Back Brace 14" tall x 16" deep, 90 degree bend, 1 1/2 x .065 4130 tube.
36300	Dragster Shoulder Hoop 19" inside x 72" tall, 1 1/2 x .058 4130 tube.
36350	Dragster Shoulder Hoop 19" inside x 36" tall, 1 1/2 x .058 4130 tube.
36360	F.E. Dragster Shoulder Hoop Up to 22" inside x 82" tall, 1 1/2 x .058 4130 tube.
36370	F.E. Dragster Lower Hoop 17" inside, 1 3/8 x .058 4130 tube w/kick up bends.
36375	F.E. Dragster Lower Hoop (1 bend) 17" inside, 1 3/8 x .058 4130 tube w/kick up bends.
36400	Dragster Support Tube (1) Upper to lower rail 1 3/8 x .095 4130 tube.
36500	Dragster Seat Former 1 1/4 x .058 4130 tube.
36550	Dragster Seat Former 1 3/8" x .058" 4130 tube
36600	Dragster Upper Engine Rails (Pair) 1 1/4" x .083" 4130 tube
36650	Dragster Upper Engine Rails (Pair) 1 1/4" x .058" 4130 tube
36700	Dragster Lower Engine Rails (Pair) 1 1/4" x .083" 4130 tube
36750	Dragster Lower Engine Rails (Pair) 1 1/4" x .058" 4130 tube
36800	Steering Mount Cross Tube 1" x .058 4130 tube.
37000	Funny Car Bend Package Roll bar, secondary roll bar, 2 back braces & shoulder hoop.
37100	Funny Car Roll Bar 29" tall x 21 1/2" centers, 1 5/8 x .083 4130 tube.
37200	Funny Car Secondary Roll Bar 19 1/2" tall x 21 1/2" centers, 1 5/8 x .083 4130 tube.
37400	Funny Car Shoulder Hoop 20" inside x 74" tall, 1 1/2 x .058 4130 tube.
38000	F.E. Dragster Bend Package Includes shoulder hoop, lower rail hoop, first and second roll bars, and the back brace.



# CHASSIS TOOLS AND INSTRUCTION

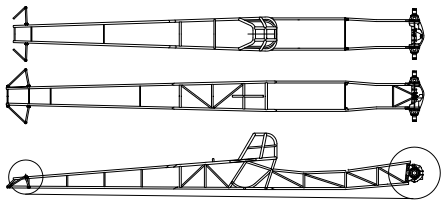

This DVD Video contains information on the BIG Picture on tubular chassis constructions. Although this video is done on a Top Alcohol Dragster from years past, its value is in knowing correct construction steps. It shows the method of building the chassis from the rear differential around the engine to the front end to result in the desired ground clearance. This general knowledge is the source for many of the current popular chassis builders today. Even If you are considering purchasing a chassis from you local builder, it will give your basic knowledge of the correct construction methods.



10004 Chassis Construction DVD

## FILLER ROD & TEMP STICK

A temp stick along with an oxy-acetylene torch should be used to normalize critical weld areas such as drivers compartment, rear end mounts etc. MW recommends ER70S-2 filler rod for tig welding chromoly. It is a triple deoxidizer for a clean and ductile weld joint.

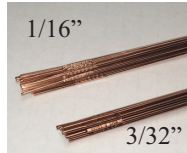

10008 Temperature Stick Indicator  
1050 degrees.

65-062 1/16" Oxweld 65 Welding Filler Rod  
*Photo shows the amount in one pound*

65-093 3/32" Oxweld 65 Welding Filler Rod  
*Photo shows the amount in one pound*

## DRIVELINE ALIGNMENT BARS

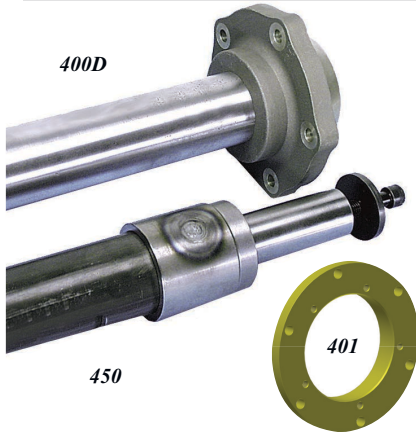

The Mark Williams 9" alignment bar is manufactured from 2-1/2" diameter heavy wall D.O.M. tubing with a CNC machined aluminum flange attached to one end. This aluminum flange bolts directly to the front of a 9" Ford thirdmember case in place of pinion support and allows for perfect alignment between rear end and engine. With an overall length of 80" this bar can be used for dragster as well as funny car/altered chassis construction. Door car chassis construction can use this also by extend the tube length with a piece of 3" x 1/4" wall tubing. This will work as long as the engine block has a 3" or larger main bore. The 12 bolt alignment bar uses a steel pilot that is inserted into the seal bore along with a standard rear pinion bearing (not supplied) to align the bar in the center section. Works with stock and MW modular 12 bolt rears.

400D 9" Ford Driveline Alignment Bar

401 Adapter to Use 400D on MW 11" Rear, Aluminum Gold Coated

450 12 Bolt Driveline Alignment Bar

## A-ARM JIG TUBE FITTING TOOLS



33600  
Spindle  
not  
included

The MW A-Arm jig simplifies installing an a-arm front end on a dragster or funny car chassis. The spindle is fastened through the upright and set to the proper caster angle with a bubble protractor. This is normally used for cars with standard 17" dragster or 15" FC spindle mount front wheels. The uprights can be positioned anywhere along the 1-1/2" square cross tube (included) to produce the desired front end tread width. The cross tube is clamped to the bottom of the chassis rails with shims to make the appropriate ground clearance.

705 Tubing Notcher

33600 A-Arm Fixture

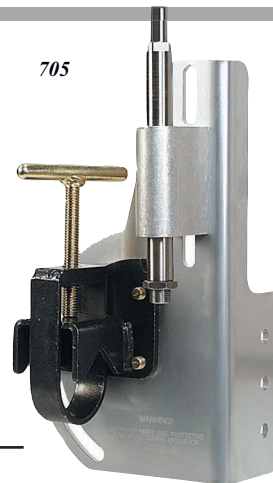

The Tubing Notcher tool will help you produce tight fitting joints that will result in better welds and a nicer finished product. This is the original Ol'Joint Jigger tool not a cheap Chinese copy. A standard bi-metal hole saw is all that's needed. The unit can be used with a drill press or a 1/2" drill motor.

# NEW PRODUCTS

## MUSTANG GT500 DRIVESHAFT

The MWS series (Mark Williams Slip) shafts were designed for the Mustang GT500 and similar models. This replaces the two-piece steel shaft that cannot handle the torque and 150+ mph speeds, and eliminates the center driveshaft support bearing with the internal slip feature. This MWS-500 shaft is made with the exclusive Gold Finish 7075 aluminum material, which is both stronger and lighter than common aluminum driveshafts, making it able to perform under the stresses where the two-piece steel shafts fail. The MW patented bonding process is used to join the end fittings, proving much stronger than the standard welding method. This shaft is made to match any Mustang transmission (automatic or stick shift) and differential flange with a 2" male pilot and 1/2" bolts on a 3" center square bolt pattern. Cars equipped with 9" Ford differentials can take advantage of this shaft using a 1350 series universal joint pinion yoke or our new Generation III 9" Ford pinion flange connection system. These shafts utilize precision Spicer 1350 universal joints and are Hi-Speed balanced to G30 specifications. The shaft run out is closely controlled. In addition, each shaft is torsion tested for additional quality assurance. Different shaft flange yoke combinations are available for attachment to different transmissions and differentials. Specific models can be designed for other applications.

MWS-500 Mustang Shaft

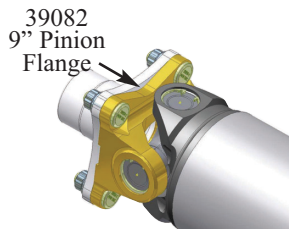

**U.S. Patent  
# 7,485,045 B2**

MWS-500 GT500 Driveshaft, Internal Slip  
*with 2 shaft flange yokes*

MWS-509 Driveshaft, Internal Slip  
*with 1 shaft flange yoke*

MWS-510 Driveshaft, Internal Slip  
*Without flange yokes utilizes standard 1350 end yokes*

## HELLCAT DRIVESHAFT

The Dodge Challenger SRT Hellcat needed some help in the driveshaft department. The factory carbon fiber shaft is a nice part but not up to the requirements when you start modifying the power output. The fact that this car has a relatively long distance from the transmission to the differential eliminates producing a one-piece shaft for high speeds and

RPM requirements. Our design utilized the two-piece construction as dictated by the shaft critical speed requirements.

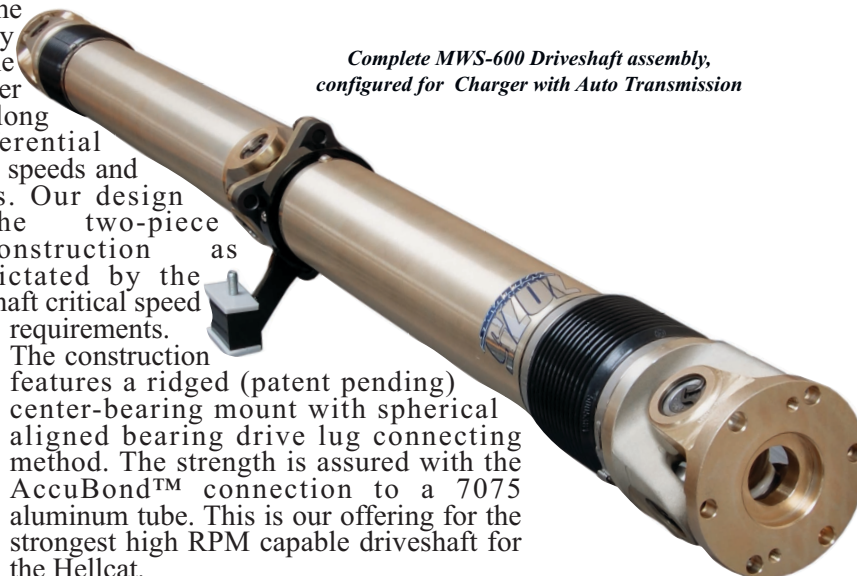

*Complete MWS-600 Driveshaft assembly, configured for Charger with Auto Transmission*

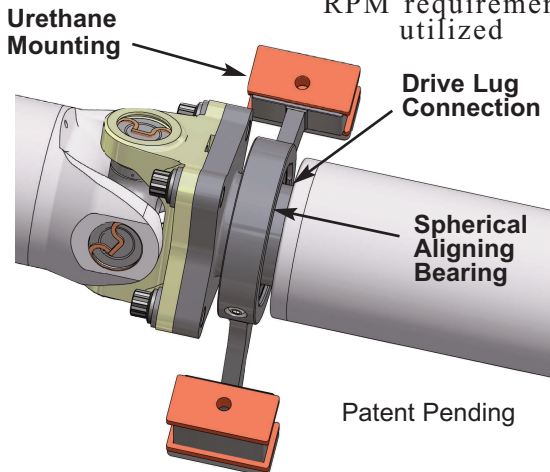

The construction features a ridged (patent pending) center-bearing mount with spherical aligned bearing drive lug connecting method. The strength is assured with the AccuBond™ connection to a 7075 aluminum tube. This is our offering for the strongest high RPM capable driveshaft for the Hellcat.

MWS-601 Hellcat Driveshaft Assembly  
*CHARGER Automatic Transmission*

MWS-600 Hellcat Driveshaft Assembly  
*Hellcat Manual Transmission*



## CLACKLE-SAFE DISCONNECT

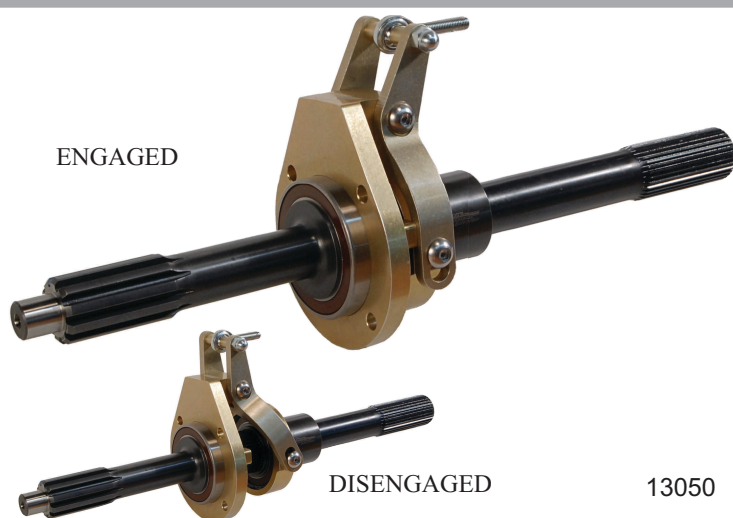

When attached to the bell housing, this device allows the driver to disconnect the output shaft from the driveshaft and safely run the car without having to hold in the clutch pedal. This eliminates the possibility of a foot slipping of the pedal and reduces wear on the clutch springs. All normal driveline couplers stay engaged and do not rotate while the engine is running. The sliding coupler, output shaft, and driveshaft are made of heat-treated alloy steel, while the bearing retainer and fork assembly are machined from billet aluminum. The output shaft and driveshaft are custom made to the length required for your car depth and engine location.

13050 Clackle-Safe Disconnect

## DRIVESHAFT SAFETY LOOPS

Our driveshaft safety loop attaches directly to the differential third member, eliminating tubular structures that attach to the chassis. By fixing the loop to the rear end the chances that the driveshaft will crash into the loop are reduced.

The front section loop is removable by four retaining bolts allowing easy drive shaft removal. The open design allows removal of the rear universal retaining bolts that are impossible to remove with enclosed tube designs. Constructed from 4130 material this satisfies the NHRA rule requirements for a "retainer loop 360 degrees of enclosure".

**Available for both 9" Ford and MW 11" differentials**

57625 Drive Shaft Loop Assembly  
*9" Thirdmember, for 7/16 stud size*

90725 Drive Shaft Loop Assembly  
*11" MODular rear, 7/16" stud size*

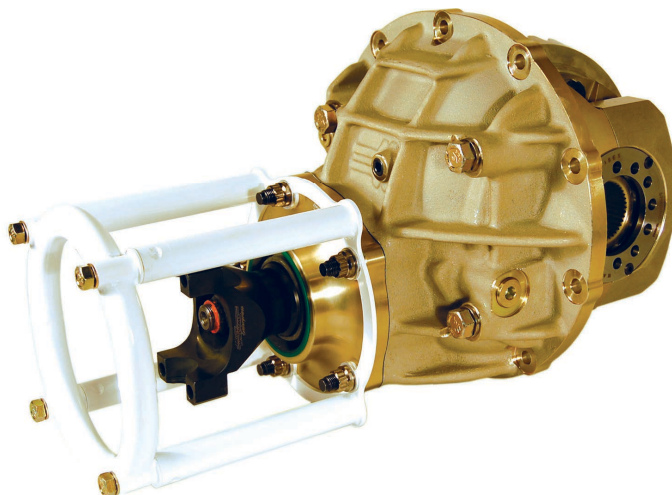

## Anti-Rotation Bracket Assy - 8 3/4 Chrysler

Designed to create the required mount plate for the rear axle rotation and drive shaft cover mounting for Front Engine Dragsters. Produced from 1/8" 4130 steel and bolted to the two existing holes in the 8 3/4" Chrysler differentials utilized in early Dragster construction. The stock thirdmember require the addition of two or three 3/8" - 16 threaded holes to mount this product. Jig welded by TIG process with three 5/16" diameter flange holes for mounting rotation device plates and drive shaft covers.



13010 Anti-Rotation Bracket 8-3/4 Mopar

## Steering Bell Crank

Designed for Front Engine Dragster steering applications. Produced from 4130 normalized steel. Features 3/8" holes on 5" arm. Bolt centers are 90 degrees apart, but can be drilled to produce different ratios. Utilizes ball bearings with races machined in to both 4130 parts. The kit includes o-ring seal, AN quality fastener, castellated nut, and cotter key. Chassis mounting bracket is formed to weld 1-1/4" to 1-1/2" diameter tubing.

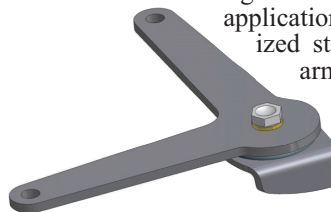

13020 Bell Crank Steering Assy

# MasterLine

For over 40 years the name "Mark Williams" has been synonymous with the ultimate in quality and reliability. But there are those racers who feel their combination doesn't require the "ultimate". With this in mind, Mark Williams Enterprises offers the **MasterLine** series of driveline components for Street and Strip (10 sec. and up) applications. **MasterLine** components include axles, bearings, spools, gear sets, and nodular iron 9" Ford cases.

## MasterLine AXLES

Machined from special alloy steel forgings, **MasterLine** axles are ideal for cars as quick as 9.90. **MasterLine** axles are all custom CNC machined to length. They feature thick flanges, 1/2" -20 threaded holes for your specific pattern. An upgrade for 5/8 stud size is available. We can provide any spline up to 35 tooth, true involute form, hobbled splines (before heat treating), an in house double heat treat, precision ground bearing journals to ensure the correct press fit of axle bearings, and adjustable bearing seats to allow precise brake system alignment.

ML-400 **MasterLine** Axles, 28 to 35 spline (pr)



ML-400 with optional triple hole pattern

## MasterLine SPOOLS

ML-132 8.8 Ford 35 Spline Spool

ML-140 9" Ford for 2.893" or 3.062" Bore Case

ML-146 9" Ford for 3.250" Bores

ML-160 12 Bolt Chevrolet 3.062 Stock Bore



**MasterLine** spools are CNC machined from alloy steel forgings and heat treated in-house. Plus, the bearing journals and ring gear flange are precision ground. All have Mark Williams 35 spline.

## MasterLine BEARINGS

ML-001 Mopar Axle Bearings, 2.875" O.D. (pr)

ML-003 Mopar Axle Brng, 2.875" w/snap ring (pr)

ML-250 Small GM "C" Clip Eliminator kit

ML-507 Ford/Olds Axle Bearings, 3.150" O.D. (pr)

ML-803 Mustang Axle Bearings, 2.835" O.D. (pr)

**MasterLine** bearings are sealed and feature a 1.562" I.D. and an "O" ring around the outside of the bearing to eliminate the need for an inner housing seal. Available for large and small Ford, Olds/Pontiac, Mopar and GM 10 & 12 Bolt C-clip eliminator kit.



## MasterLine DRIVESHAFTS

**MasterLine** driveshafts are custom built from 3" x .083 DOM mild steel tubing or 6061 aluminum with Spicer 1350 series weld yokes and Spicer precision 1350 series U joints. Special assembly fixtures guarantee proper weld yoke phasing during assembly. Every shaft is electronically balanced with the transmission yoke installed to ensure vibration free operation. Prices includes the forged billet MW4340 transmission yoke.

ML-39200

ML-600 3" x .083 Mild Steel Driveshaft

*Any length with u-joints, includes transmission yoke.*

ML-39200 3.5" x .125" 6061 Aluminum Shaft

*Any length with u-joints, Includes transmission yoke.*

ML-39300 4" x .125" 6061 Aluminum Shaft

*Any length with u-joints, includes transmission yoke.*



## MasterLine CASES

**MasterLine** nodular cases feature tough nodular iron castings that are CNC machined, billet steel main caps and bearing adjusters, and extra reinforced pilot bearing area. (3/8" pinion support studs are available)

ML-460 Nodular Iron Case w/ 3.062" Bores

*Steel caps and billet adjusters, adjuster locks*

ML-470 Nodular Iron Case w/ 3.250" Bores

*Steel caps and billet adjusters, adjuster locks*



# CHASSIS PLANS

For those drag racers that want to build their own race car from scratch, Mark Williams offers the plans and bill of materials required for the construction. Plans are available for several Dragster chassis or A-Modified/Funny car. The material specified will conform to the appropriate SFI (SEMA Foundation Inc.) specification, if constructed accordingly. Since their introduction, MW kit car plans have proven to be very competitive in various classes ranging from Economy Modified to Alcohol dragsters. The construction of any chassis requires a level of experience necessary to complete the project satisfactorily. We are supplying the basic dimensioned print for each chassis. No two cars are built alike, and you will find it necessary to determine dimensions based on engine placement, transmission type, driver size, wheel base, and ground clearance desired. The tubing will need to be fitted for each joint utilizing a tool specifically for "fish mousing" joints. We suggest purchasing the DVD video to review the construction methods before committing to build the chassis from the prints.

10004 Dragster Chassis Construction Video DVD (Covers solid mount dragster chassis construction only)

## SOLID REAR ENGINE DRAGSTER PLANS

Top Alcohol type chassis plans designed with solid mounted 92000 MW modular 9" aluminum housing. This chassis is to be constructed with the 11" Modular rear end. Plans include a bill of materials list. Parts list includes: Steering hardware with rack and pinion box, engine mounting plates, and all of the pre bent and straight tubing required to build a chassis. The drawing can be used to build a chassis that meets the SFI 2.3K chassis specs.

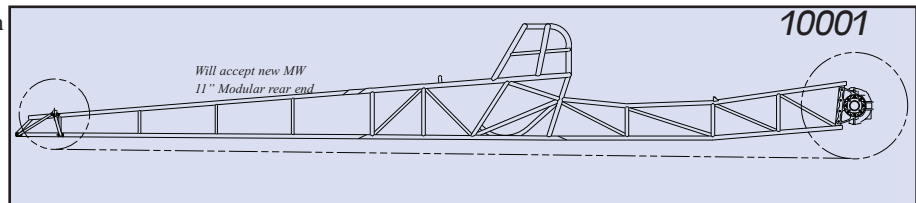

10001 Plans and Bill of Materials List, Top Alcohol Dragster

## 4-LINK ENGINE DRAGSTER PLANS

Chromoly chassis with unique monoshock rear suspension and MW modular 12 bolt housing w/billet aluminum 4 link brackets. Plans bill of materials includes monoshock rocker shaft and arms, 4-link and wishbone kits, complete steering with rack and pinion box, engine mounting plates and all the pre bent and straight tubing to build a chassis that meets the current SFI 2.5 chassis specs.

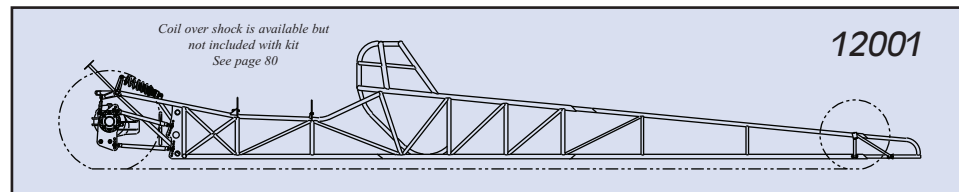

12001 Dragster Blueprint and Bill of Materials, 4-Link Suspension

## FRONT ENGINE DRAGSTER PLANS

Chromoly chassis with 92000 MW modular 9" aluminum housing. Meets the current SFI 2.2B chassis specs for new front engine dragsters (6.29 and quicker). Plans include bill of materials for: modular housing steering with standard box, engine mounting plates and all of the pre bent and straight tubing to build a basic chassis. Supercharged applications will require a full floater housing.

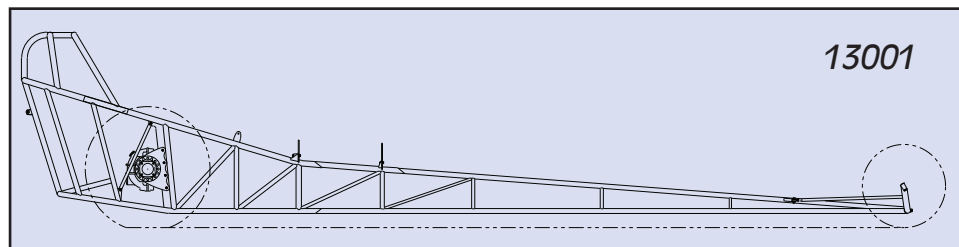

13001 Front Engine Dragster Blueprint and Bill of Materials

*We can still supply all of the components that were available in the kit car packages.*

# FUNNY CAR/ALTERED PLANS

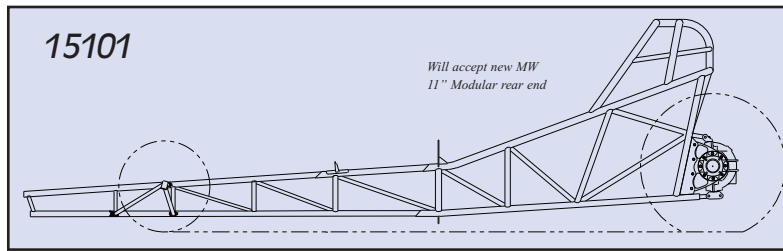

Plans are designed utilizing the 92000 MW modular 9" or 11" Modular aluminum housing. Bill of materials include: Spindles and linkage for standard box, engine mounting plates and all the pre bent and straight tubing to build a basic chassis that will meet the current SFI 10.1E chassis specs for new Funny Car or Altered. When built to print chassis can be certified for any class up to Nitro Funny Car. Supercharged applications will require a full floater housing.

15101 Funny Car or Altered Blueprint and Bill of Materials

## PROMOTIONAL ITEMS



WC-50



DEC



WC



CAPMW



CAP-BK/SILVER



MWTAPE



DSP

- WC Wall Clock Axle Logo
- WC-50 Wall Clock 50TH Logo
- MWTAPE Inch/Metric 10' Tape
- ML-DEC MasterLine Round Decal
- DEC MW Round Decal
- DEC-DS MW Driveshaft Decal (die cut)
- DEC-DB MW Disc Brake Decal (die cut)
- DSP Driveshaft Poster 24" X 36" .Free with Purchase

- CAPMW Cap MW Long Logo
- (Blue) CAP-BK/SILVER Cap Axle
- T-FC MW cotton T-shirt, Funny Car (specify size)  
*Black or white, specify size*
- T-PM MW cotton T-shirt, Pro Mod (specify size)  
*Black or white, specify size*
- T-PS MW cotton T-shirt, Pro Stock (specify size)  
*Black or white, specify size*
- T-SS MW cotton T-shirt, Super Stock (specify size)  
*Black or white, specify size*

