

PERFORMANCE MUFFLERS UNIVERSAL TIPS & ACCESSORIES MAGNAFLOW GEAR

PERFORMANCE MUFFLERS

OVAL BODY MUFFLERS.....	01 - 04
ROUND BODY MUFFLERS.....	05 - 06
GLASSPACK MUFFLERS.....	07 - 07
RACE MUFFLERS.....	08 - 08
MUFFLERS WITH TIPS.....	09 - 14
XL MUFFLERS.....	15 - 15

UNIVERSAL TIPS & ACCESSORIES

UNIVERSAL TIPS.....	16 - 20
TRANSITION PIPES & CLAMPS.....	21 - 21
PERFORMANCE ACCESSORIES.....	22 - 23

MAGNAFLOW GEAR

ACCESSORIES.....	24 - 24
TEES.....	25 - 26
HOODIES.....	27 - 27

STRAIGHT THROUGH

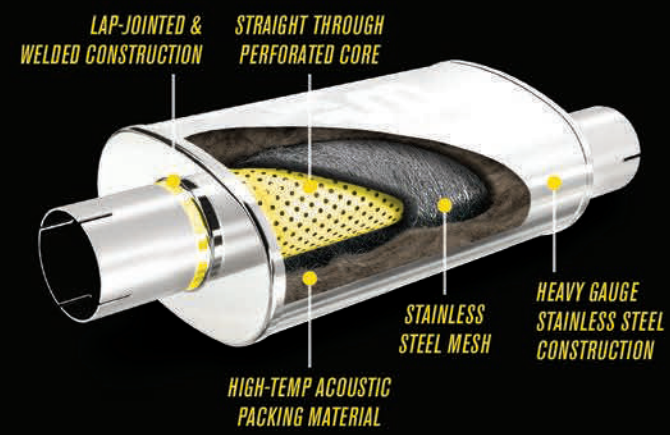

GLASSPACK

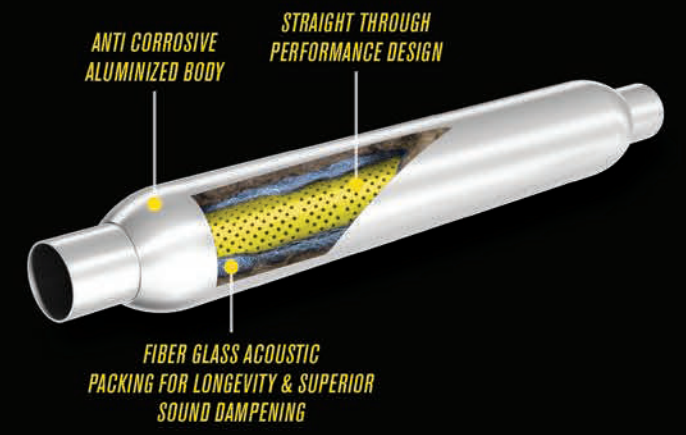

RACE MUFFLERS

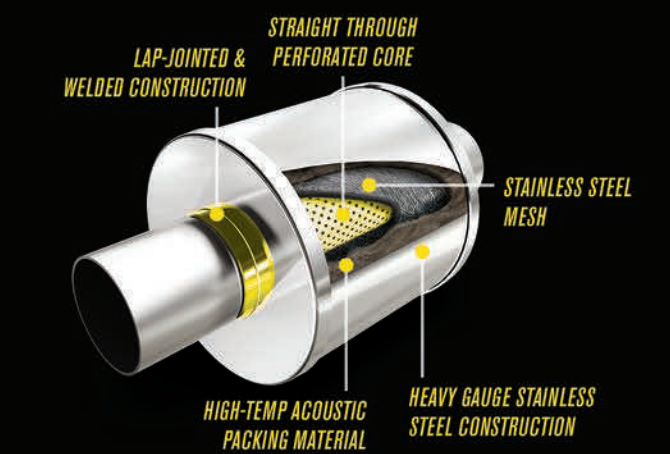

MUFFLERS WITH TIPS

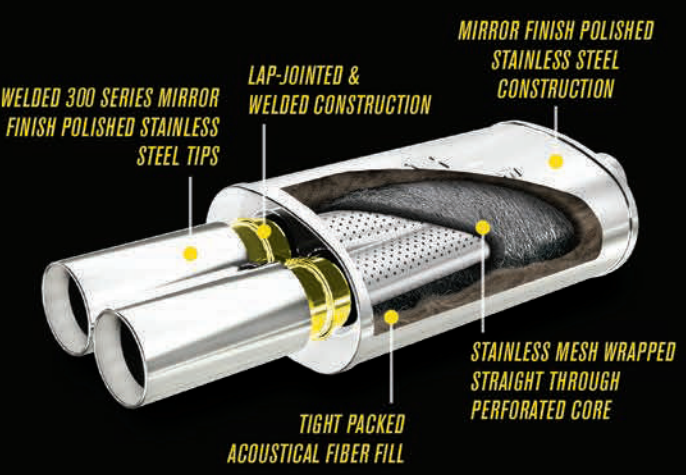

XL MUFFLERS

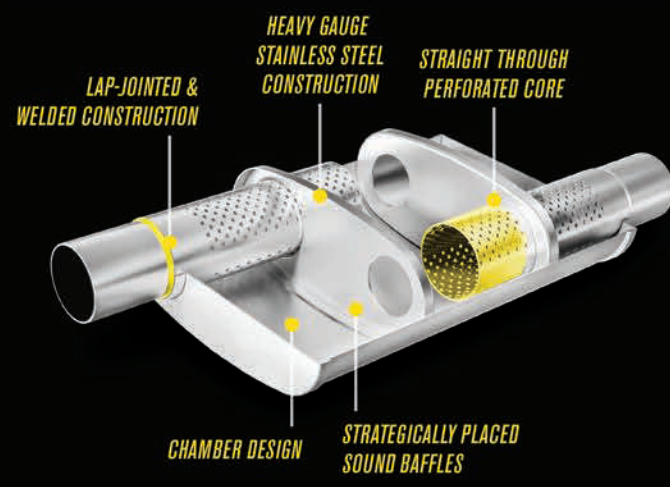

OVAL BODY MUFFLERS



OVAL BODY MUFFLERS



3.5"x7" OVAL BODY MUFFLERS

11" OFFSET/OFFSET

IN/OUT	STAINLESS	POLISH-SS
2"/2.25"	11132	N/A

14" CENTER/CENTER

IN/OUT	STAINLESS	POLISH-SS
1.75"	11113	N/A
2"	11114	N/A

14" CENTER/OFFSET

IN/OUT	STAINLESS	POLISH-SS
1.75"	11123	N/A
2"	11124	N/A

14" OFFSET/OFFSET

IN/OUT	STAINLESS	POLISH-SS
1.75"	11133	N/A
2"	11134	N/A

14" SINGLE/DUAL

IN/OUT	STAINLESS	POLISH-SS
2.25"/2" Dual	11148	N/A

4"x9" OVAL BODY MUFFLERS (cont.)

14" OFFSET/OFFSET SAME SIDE

IN/OUT	STAINLESS	POLISH-SS
2.5"	N/A	14377

14" DUAL/DUAL

IN/OUT	STAINLESS	POLISH-SS
2.25"	11385*	14385*
2.5"	11386*	14386*

*Tru-X Perforated Core

18" CENTER/CENTER

IN/OUT	STAINLESS	POLISH-SS
2"	11244	N/A
2.25"	11245	N/A
2.5"	11246	N/A
3"	11249	N/A

18" CENTER/OFFSET

IN/OUT	STAINLESS	POLISH-SS
2"	11254	N/A
2.25"	11255	14355
2.5"	11256	14356
3"	11259	14359

18" OFFSET/OFFSET

IN/OUT	STAINLESS	POLISH-SS
2"	11264	N/A
2.25"	11265	14365
2.5"	11266	14366

4"x9" OVAL BODY MUFFLERS

11" CENTER/OFFSET

IN/OUT	STAINLESS	POLISH-SS
2.25"	11365	14362
2.5"	11366	14363

11" OFFSET/OFFSET SAME SIDE

IN/OUT	STAINLESS	POLISH-SS
2.25"	11375	14375
2.5"	11376	14376

11" DUAL/DUAL

IN/OUT	STAINLESS	POLISH-SS
2.25"	11378	14378
2.5"	11379	14379

14" CENTER/CENTER

IN/OUT	STAINLESS	POLISH-SS
2"	11214	N/A
2.25"	11215	14315
2.5"	11216	14316
3"	11219	14319

14" CENTER/OFFSET

IN/OUT	STAINLESS	POLISH-SS
2"	11224	14324
2.25"	11225	14325
2.5"	11226	14326
3"	11229	14329

14" OFFSET/OFFSET

IN/OUT	STAINLESS	POLISH-SS
2"	11234	N/A
2.25"	11235	14335
2.5"	11236	14336

5"x8" OVAL BODY MUFFLERS

6" CENTER/CENTER

IN/OUT	STAINLESS	POLISH-SS
2.5"	N/A	14148
3"	N/A	14149
3.5"	N/A	14150
4"	N/A	14152

14" CENTER/CENTER

IN/OUT	STAINLESS	POLISH-SS
3.5"	N/A	14151
4"	N/A	14153
2"	12214	14214
2.25"	12215	14215
2.5"	12216	14216
3"	12219	14219

14" CENTER/OFFSET

IN/OUT	STAINLESS	POLISH-SS
2"	12224	N/A
2.25"	12225	14225
2.5"	12226	14226
3"	12229	14229

14" OFFSET/OFFSET

IN/OUT	STAINLESS	POLISH-SS
2.25"	N/A	14235
2.5"	N/A	14236
3"	N/A	14239

14" SINGLE/DUAL

IN/OUT	STAINLESS	POLISH-SS
2"/2" Dual	12128	14222
2.25"/2" Dual	12148	14220
2.25"/2.25" Dual	12138	14223
2.5"/2.5" Dual	12158	14218
3"/2.5" Dual	12198	14221

14" OFFSET/OFFSET SAME SIDE

IN/OUT	STAINLESS	POLISH-SS
2.5"	N/A	14211

OVAL BODY MUFFLERS



OVAL BODY MUFFLERS



5"x8" OVAL BODY MUFFLERS (cont.)

14" OFFSET/OFFSET SAME END

IN/OUT	STAINLESS	POLISH-SS
2.5"	N/A	14210

18" CENTER/CENTER

IN/OUT	STAINLESS	POLISH-SS
2"	12244	N/A
2.25"	12245	14245
2.5"	12246	14246
3"	12249	14249

18" CENTER/OFFSET

IN/OUT	STAINLESS	POLISH-SS
2"	12254	N/A
2.25"	12255	14255
2.5"	12256	14256
3"	12259	14259

18" OFFSET/OFFSET

IN/OUT	STAINLESS	POLISH-SS
2.25"	N/A	14262
2.5"	N/A	14263
3"	N/A	14264

18" SINGLE/DUAL

IN/OUT	STAINLESS	POLISH-SS
2.25"/2.25" Dual	12251	N/A
2.5"/2" Dual	12280	N/A
2.5"/2.25" Dual	12258	14258
2.5"/2.5" Dual	12268	N/A
3"/2.25" Dual	12278	14278
3"/2.5" Dual	12288	14288
3"/3" Dual	12298	14298

18" DUAL/DUAL

IN/OUT	STAINLESS	POLISH-SS
2.5"	12468*	14468*
3"	12469	N/A

*Tru-X Perforated Core

24" CENTER/CENTER

IN/OUT	STAINLESS	POLISH-SS
2.5"	12276	N/A
3"	12279	N/A

24" CENTER/OFFSET

IN/OUT	STAINLESS	POLISH-SS
2.5"	12286	14250
3"	12289	14251

24" OFFSET/OFFSET

IN/OUT	STAINLESS	POLISH-SS
2.5"	N/A	14260
3"	N/A	14261

24" SINGLE/DUAL

IN/OUT	STAINLESS	POLISH-SS
2.5"/2.5" Dual	12368	N/A
3"/2.5" Dual	12388	N/A
3"/3" Dual	12398	N/A

CAMARO/FIREBIRD

IN/OUT	STAINLESS	POLISH-SS
2.5"/2.25"	12266	14266
2.5"/2.5"	12265	N/A
3"/2.5"	12267	14267

*Camaro mufflers are not reversible

5"x11" OVAL BODY MUFFLERS

22" CENTER/CENTER

IN/OUT	STAINLESS	POLISH-SS
2.5"	12576	14576
3"	12579	14579

22" CENTER/OFFSET

IN/OUT	STAINLESS	POLISH-SS
2.5"	12586	14586
3"	12589	14589
3.5"	12909	14909

22" OFFSET/OFFSET

IN/OUT	STAINLESS	POLISH-SS
2.5"	12577	14577
3"	12578	14578

22" SINGLE/DUAL

IN/OUT	STAINLESS	POLISH-SS
2.5"/2.25" Dual	12580	14580
3"/2.5" Dual	12588	14588
3"/3" Dual	12590	14590
3.5"/2.5" Dual	12587	14587
4"/3" Dual	12594	14594
3.5"/3" Dual	12595	14595

22" DUAL/DUAL

IN/OUT	STAINLESS	POLISH-SS
2.5"	12568*	14568*
3"/2.5"	12569*	N/A
3"	12599*	N/A

*Tru-X Perforated Core

ROUND BODY MUFFLERS



4" ROUND BODY MUFFLERS

14" CENTER/CENTER

IN/OUT	CORE	STAINLESS	POLISH-SS
2"	2.5"	10414	14414
2.25"	2.5"	10415	14415
2.5"	2.5"	10416	14416
3"	3"	N/A	14419
2"	2"	10444	14444
2.25"	2"	10445	14445

18" CENTER/CENTER

IN/OUT	STAINLESS	POLISH-SS
2"	10424	N/A
2.25"	10425	N/A
2.5"	10426	N/A

22" CENTER/CENTER

IN/OUT	STAINLESS	POLISH-SS
2"	10434	N/A
2.25"	10435	N/A
2.5"	10436	N/A

5" ROUND BODY MUFFLERS

14" CENTER/CENTER

IN/OUT	STAINLESS	POLISH-SS
2.25"	12865	14865
2.5"	12866	14866
3"	12867	14867

6" ROUND BODY MUFFLERS

6" CENTER/CENTER

IN/OUT	STAINLESS	POLISH-SS
2.5"	N/A	14158
3"	N/A	14159
3.5"	N/A	14160
4"	N/A	14162

14" CENTER/CENTER

IN/OUT	STAINLESS	POLISH-SS
3.5"	N/A	14161
4"	N/A	14163
2"	12614	14614
2.25"	12615	14615
2.5"	12616	14616
3"	12619	14619

14" OFFSET/OFFSET

IN/OUT	STAINLESS	POLISH-SS
2"	12634	N/A
2.25"	12635	N/A
2.5"	12636	N/A

18" CENTER/CENTER

IN/OUT	STAINLESS	POLISH-SS
2"	12644	N/A
2.25"	12645	N/A
2.5"	12646	N/A
3"	12649	N/A

27" CENTER/CENTER

IN/OUT	STAINLESS	POLISH-SS
2.5"	12640	N/A

30" CENTER/CENTER

IN/OUT	STAINLESS	POLISH-SS
3"	12641	14641

7" ROUND BODY MUFFLERS



7" ROUND BODY MUFFLERS

14" CENTER/CENTER

IN/OUT	STAINLESS	POLISH-SS
2"	N/A	14714
2.25"	N/A	14715
2.5"	N/A	14716
3"	N/A	14719

24" SINGLE/DUAL

IN/OUT	STAINLESS	POLISH-SS
3"/2.5" Dual	12763	N/A

27" SINGLE/DUAL

IN/OUT	STAINLESS	POLISH-SS
2.5"/2.25" Dual	12761	N/A

30" SINGLE/DUAL

IN/OUT	STAINLESS	POLISH-SS
3"/2.5" Dual	12762	N/A

7" ROUND BODY DIESEL MUFFLERS

14" CENTER/CENTER

IN/OUT	STAINLESS	POLISH-SS
4"	12770	14770

20" CENTER/CENTER

IN/OUT	STAINLESS	POLISH-SS
4"	12771	14771

24" CENTER/CENTER

IN/OUT	STAINLESS	POLISH-SS
4"	12772	14772

24" CENTER/CENTER

IN/OUT	STAINLESS	POLISH-SS
5"	12774	14774

30" CENTER/CENTER

IN/OUT	STAINLESS	POLISH-SS
4"	12773	14773

34" MUFFLER DELETE

TRIM TO FIT

IN/OUT	STAINLESS
4"	15451

3.5" ROUND BODY GLASSPACKS

12" BODY

IN/OUT	ALUMINIZED
1.75"	18113
2"	18114
2.25"	18115

18" BODY

IN/OUT	ALUMINIZED	IN/OUT	REDPACK
2"	18124	2"	13124
2.25"	18125	2.25"	13125

22" BODY

IN/OUT	ALUMINIZED	IN/OUT	REDPACK
2"	18134	2"	13134
2.25"	18135	2.25"	13135

26" BODY

IN/OUT	ALUMINIZED	IN/OUT	REDPACK
2"	18144	2"	13144
2.25"	18145	2.25"	13145

4" ROUND BODY GLASSPACKS

18" BODY

IN/OUT	ALUMINIZED	IN/OUT	REDPACK
3"	18129	3"	13129

26" BODY

IN/OUT	ALUMINIZED	IN/OUT	REDPACK
2.5"	18146	2.5"	13146

4" ROUND BODY RACE MUFFLERS

4" CENTER/ CENTER

IN/OUT	LENGTH	OVERALL	POLISH-SS
2.5"	6"	12"	14156

5"x8" OVAL BODY RACE MUFFLERS

5"x8" CENTER/ CENTER

IN/OUT	LENGTH	OVERALL	PART#
2.5"	6"	12"	14148
3"	6"	12"	14149
3.5"	6"	12"	14150
4"	6"	12"	14152

5"x8" CENTER/ CENTER

IN/OUT	LENGTH	OVERALL	PART#
3.5"	14"	20"	14151
4"	14"	20"	14153

6" ROUND BODY RACE MUFFLERS

6" CENTER/ CENTER

IN/OUT	LENGTH	OVERALL	PART#
2.5"	6"	12"	14158
3"	6"	12"	14159
3.5"	6"	12"	14160
4"	6"	12"	14162

14" CENTER/CENTER

IN/OUT	LENGTH	OVERALL	PART#
3.5"	14"	20"	14161
4"	14"	20"	14163

MUFFLERS WITH TIPS



5"x8" OVAL DUALS STREET

STREET PART# 14801

TIP TYPE
Round DTM
Single Wall

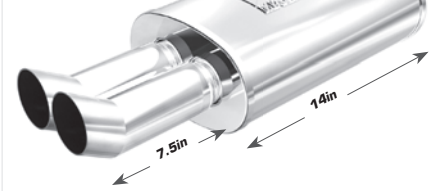

TIP DIA.	CORE SIZE	INLET SIZE
2.5"	2"	2.25"

STREET PART# 14803

TIP TYPE
Round DTM
Single Wall

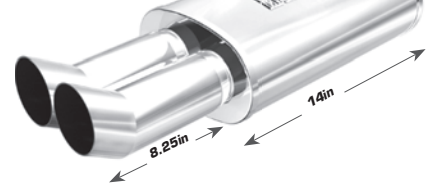

TIP DIA.	CORE SIZE	INLET SIZE
3"	2"	2.25"

STREET PART# 14862

TIP TYPE
Round Angle Cut Rolled Edge
Double Wall



TIP DIA.	CORE SIZE	INLET SIZE
3"	2"	2.25"

STREET PART# 14804

TIP TYPE
Square DTM
Single Wall



TIP DIA.	CORE SIZE	INLET SIZE
3"	2"	2.25"

STREET PART# 14863

TIP TYPE
Rectangle Straight Cut Rolled Edge
Double Wall



TIP DIA.	CORE SIZE	INLET SIZE
3"x3.75"	2"	2.25"

STREET PART# 14815

TIP TYPE
Round Straight Cut
Double Wall



TIP DIA.	CORE SIZE	INLET SIZE
3"	2"	2.25"

STREET PART# 14805

TIP TYPE
Round Straight Cut
Double Wall

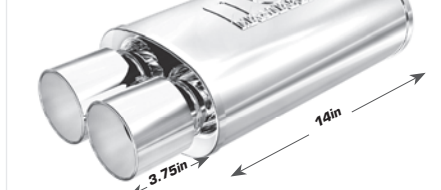

TIP DIA.	CORE SIZE	INLET SIZE
3.5"	2"	2.25"

STREET PART# 14816

TIP TYPE
Round Straight Cut
Double Wall



TIP DIA.	CORE SIZE	INLET SIZE
3.5"	2"	2.25"

STREET PART# 14807

TIP TYPE
Round Straight Cut
Double Wall



TIP DIA.	CORE SIZE	INLET SIZE
4"	2"	2.25"

STREET PART# 14830

TIP TYPE
Oval Angle Cut Rolled Edge
Single Wall



TIP DIA.	CORE SIZE	INLET SIZE
3.25"x2.5"	2"	2.25"

STREET PART# 14833

TIP TYPE
Rectangle Angle Cut Rolled Edge
Single Wall



TIP DIA.	CORE SIZE	INLET SIZE
2.75"x2.5"	2"	2.25"

5"x8" OVAL SINGLE

STREET PART# 14818

TIP TYPE
Round Straight Cut
Single Wall

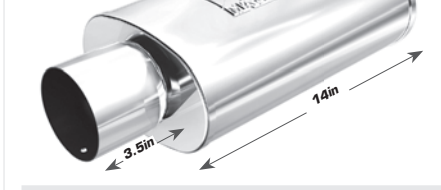

TIP DIA.	CORE SIZE	INLET SIZE
4"	2.5"	2.25"

STREET PART# 14832

TIP TYPE
Round Straight Cut
Double Wall

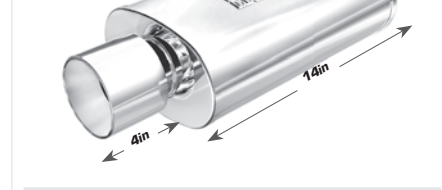

TIP DIA.	CORE SIZE	INLET SIZE
4"	2.5"	2.25"

STREET PART# 14814

TIP TYPE
Round Angle Cut
Double Wall

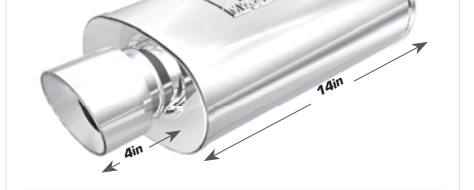

TIP DIA.	CORE SIZE	INLET SIZE
4"	2.5"	2.25"

STREET PART# 14827

TIP TYPE
Round Angle Cut
Single Wall

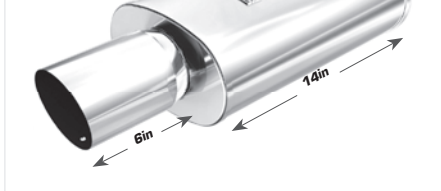

TIP DIA.	CORE SIZE	INLET SIZE
4"	2.5"	2.25"

STREET PART# 14829

TIP TYPE
Round Angle Cut
Double Wall

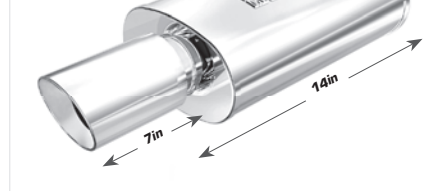

TIP DIA.	CORE SIZE	INLET SIZE
4"	2.5"	2.25"

COMPETITION CORE PART# 14819

TIP TYPE
Round Angle Cut
Double Wall

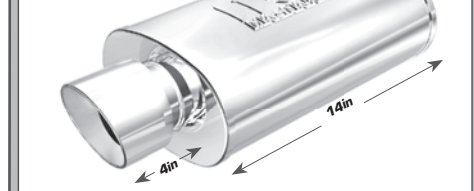

TIP DIA.	CORE SIZE	INLET SIZE
4"	3"	3"

COMPETITION CORE PART# 14835

TIP TYPE
Round Angle Cut
Double Wall

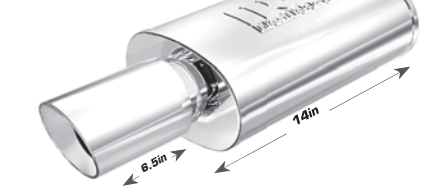

TIP DIA.	CORE SIZE	INLET SIZE
4"	3"	3"

COMPETITION CORE PART# 14851

TIP TYPE
Round Angle Cut
Double Wall

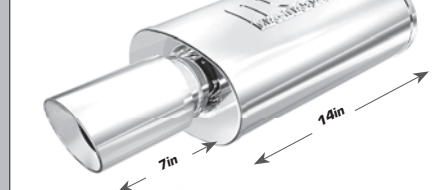

TIP DIA.	CORE SIZE	INLET SIZE
4"	2.5"	2.25"

COMPETITION CORE PART# 14850

TIP TYPE
Round Straight Cut
Single Wall

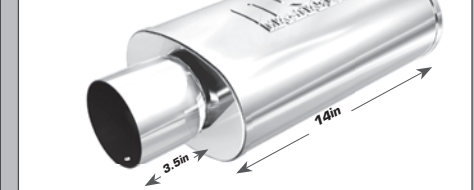

TIP DIA.	CORE SIZE	INLET SIZE
4"	2.5"	2.25"

COMPETITION CORE PART# 14828

TIP TYPE
Round Angle Cut
Single Wall



TIP DIA.	CORE SIZE	INLET SIZE
4"	3"	3"

COMPETITION CORE PART# 14834

TIP TYPE
Round Angle Cut
Single Wall

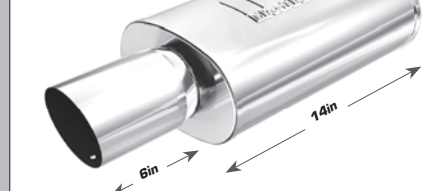

TIP DIA.	CORE SIZE	INLET SIZE
4"	3"	3"

STREET
High flow tuning tube performance.
Balanced exterior/interior sound.

COMPETITION CORE
Straight through competition core power.
Maximum flow with an aggressive tone.

TUNABLE
Adjustable sound damper to customize tone.
Exhaust noise levels tuned to personal preference.

BLACK
High temp satin black ceramic coating.
Aggressive style and enhanced protection.

MUFFLERS WITH TIPS



4" ROUND BODY

STREET PART# 14810



TIP DIA.	CORE SIZE	INLET SIZE
3.5"	2.5"	2.25"

5" ROUND BODY

STREET PART# 14855



TIP DIA.	CORE SIZE	INLET SIZE
4"	2.5"	2.25"

STREET PART# 14858

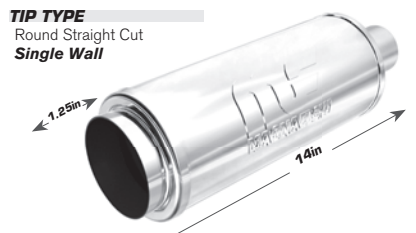

TIP DIA.	CORE SIZE	INLET SIZE
4"	2.5"	2.25"

STREET PART# 14860



TIP DIA.	CORE SIZE	INLET SIZE
4"	2.5"	2.25"

STREET PART# 14857

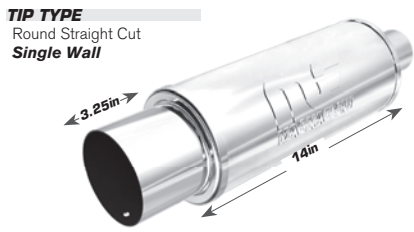

TIP DIA.	CORE SIZE	INLET SIZE
4"	2.5"	2.25"

STREET PART# 14859

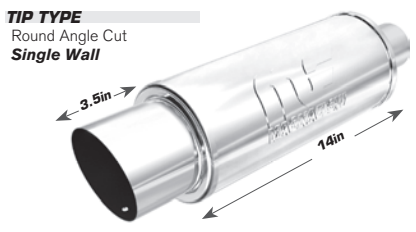

TIP DIA.	CORE SIZE	INLET SIZE
4"	2.5"	2.25"

5" TUNABLE PART# 14852



TIP DIA.	CORE SIZE	INLET SIZE
4"	2.5"	2.25"

5" TUNABLE PART# 14853



TIP DIA.	CORE SIZE	INLET SIZE
4"	2.5"	2.25"

5" TUNABLE PART# 14854



TIP DIA.	CORE SIZE	INLET SIZE
4"	2.5"	2.25"

5" TUNABLE PART# 14856



TIP DIA.	CORE SIZE	INLET SIZE
4"	2.5"	2.25"

6" ROUND BODY

STREET PART# 14847

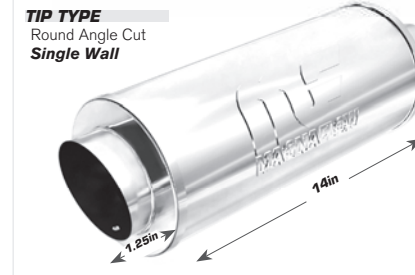

TIP DIA.	CORE SIZE	INLET SIZE
4"	2.5"	2.25"

COMPETITION CORE PART# 14849

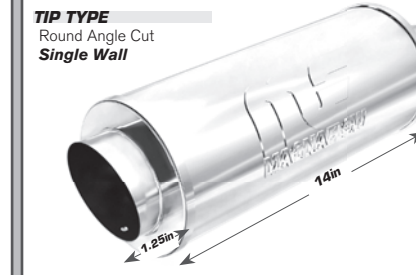

TIP DIA.	CORE SIZE	INLET SIZE
4"	2.5"	2.25"

STREET PART# 14821

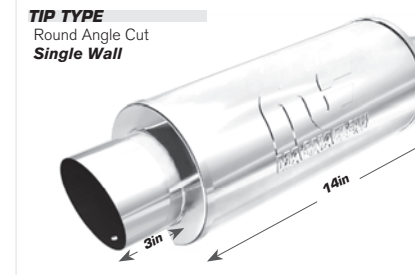

TIP DIA.	CORE SIZE	INLET SIZE
4"	2.5"	2.25"

STREET PART# 14846

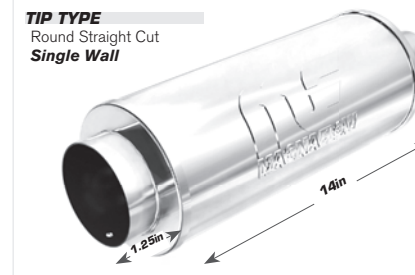

TIP DIA.	CORE SIZE	INLET SIZE
4"	2.5"	2.25"

COMPETITION CORE PART# 14848

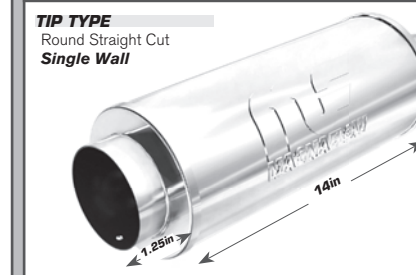

TIP DIA.	CORE SIZE	INLET SIZE
4"	2.5"	2.25"

STREET PART# 14822

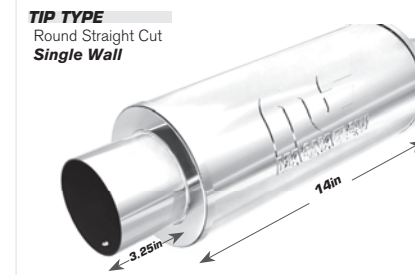

TIP DIA.	CORE SIZE	INLET SIZE
4"	2.5"	2.25"

STREET PART# 14817

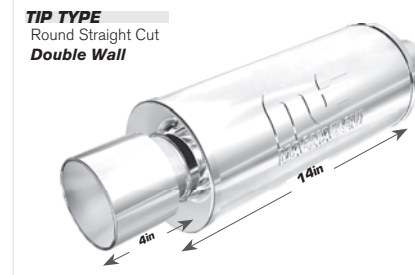

TIP DIA.	CORE SIZE	INLET SIZE
4"	2.5"	2.25"

COMPETITION CORE PART# 14840

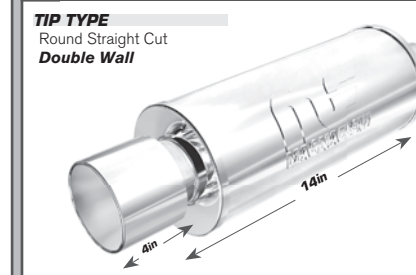

TIP DIA.	CORE SIZE	INLET SIZE
4"	2.5"	2.25"

STREET PART# 14813

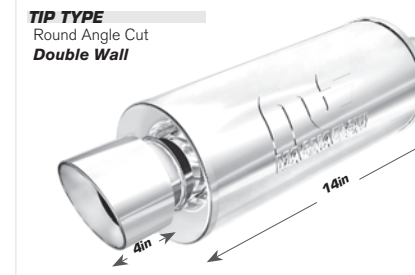

TIP DIA.	CORE SIZE	INLET SIZE
4"	2.5"	2.25"

STREET PART# 14823

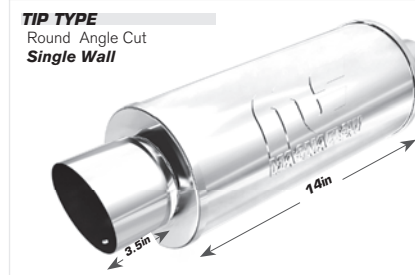

TIP DIA.	CORE SIZE	INLET SIZE
4"	2.5"	2.25"

COMPETITION CORE PART# 14842

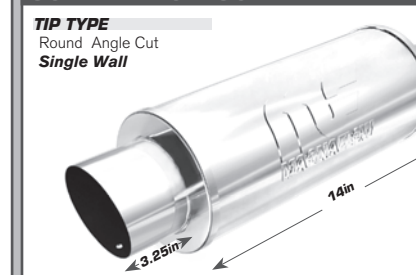

TIP DIA.	CORE SIZE	INLET SIZE
4"	2.5"	2.25"

STREET PART# 14864

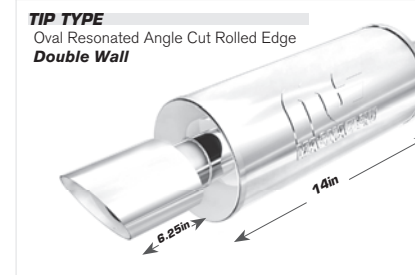

TIP DIA.	CORE SIZE	INLET SIZE
3.25"x4.5"	2.5"	2.25"

STREET
High flow tuning tube performance.
Balanced exterior/interior sound.

COMPETITION CORE
Straight through Competition Core power.
Maximum flow with an aggressive tone.

TUNABLE
Adjustable sound damper to customize tone.
Exhaust noise levels tuned to personal preference.

BLACK
High temp satin black ceramic coating.
Aggressive style and enhanced protection.

MUFFLERS WITH TIPS



MUFFLERS WITH TIPS



6" ROUND BODY (cont.)

STREET PART# 14820



TIP DIA.	CORE SIZE	INLET SIZE
4"	2.5"	2.25"

COMPETITION CORE PART# 14843

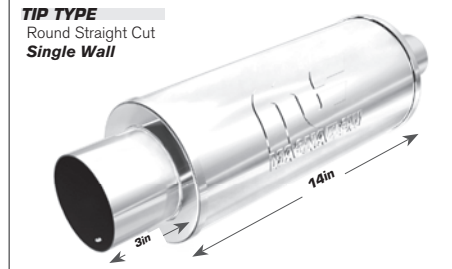

TIP DIA.	CORE SIZE	INLET SIZE
4"	2.5"	2.25"

STREET PART# 14811



TIP DIA.	CORE SIZE	INLET SIZE
4"	2.5"	2.25"

7" ROUND BODY

STREET PART# 14812

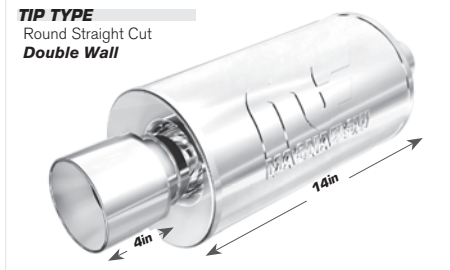

TIP DIA.	CORE SIZE	INLET SIZE
4"	2.5"	2.25"

STREET PART# 14825

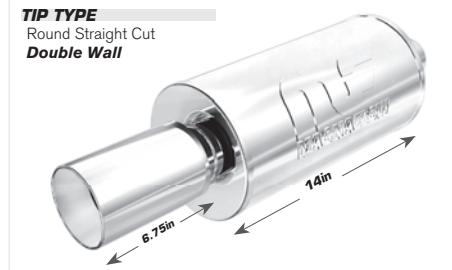

TIP DIA.	CORE SIZE	INLET SIZE
4"	2.5"	2.25"

COMPETITION CORE PART# 14806

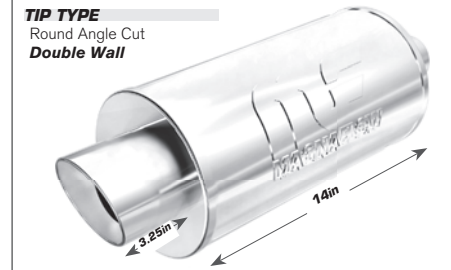

TIP DIA.	CORE SIZE	INLET SIZE
4"	3"	3"

STREET PART# 14826

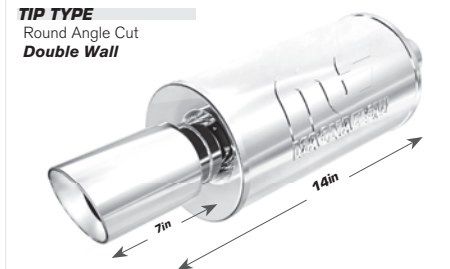

TIP DIA.	CORE SIZE	INLET SIZE
4"	2.5"	2.25"

STREET PART# 14836



TIP DIA.	CORE SIZE	INLET SIZE
4.5"	2.5"	2.25"

STREET PART# 14824

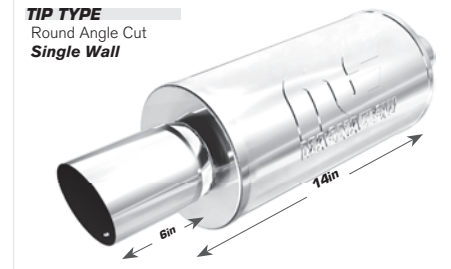

TIP DIA.	CORE SIZE	INLET SIZE
4"	2.5"	2.25"

STREET
High flow tuning tube performance.
Balanced exterior/interior sound.

COMPETITION CORE
Straight through Competition Core power.
Maximum flow with an aggressive tone.

TUNABLE
Adjustable sound damper to customize tone.
Exhaust noise levels tuned to personal preference.

BLACK
High temp satin black ceramic coating.
Aggressive style and enhanced protection.

BLACK

STREET 5" Round Body PART# 14869

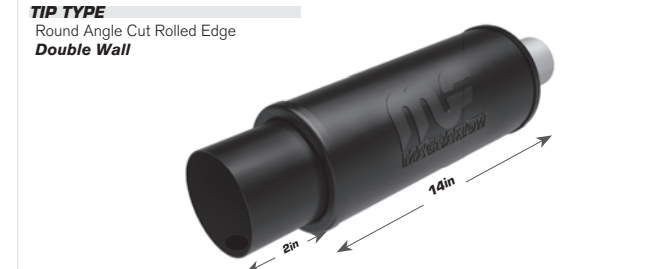

TIP DIA.	CORE SIZE	INLET SIZE
4"	2.5"	2.25"

STREET 6" Round Body PART# 14870



TIP DIA.	CORE SIZE	INLET SIZE
4"	2.5"	2.25"

STREET 5" x 8" Oval Single PART# 14868



TIP DIA.	CORE SIZE	INLET SIZE
4"	2.5"	2.25"

STREET 5" x 8" Oval Duals PART# 14871



TIP DIA.	CORE SIZE	INLET SIZE
3"	2"	2.25"

STREET
High flow tuning tube performance.
Balanced exterior/interior sound.

COMPETITION CORE
Straight through Competition Core power.
Maximum flow with an aggressive tone.

TUNABLE
Adjustable sound damper to customize tone.
Exhaust noise levels tuned to personal preference.

BLACK
High temp satin black ceramic coating.
Aggressive style and enhanced protection.

4"x9" 3 CHAMBER

14" CENTER/OFFSET

IN/OUT	PART#
2"	13214
2.25"	13215
2.5"	13216
3"	13219

14" OFFSET/OFFSET

IN/OUT	PART#
2"	13234
2.25"	13235
2.5"	13236
3"	13239

14" SINGLE/DUAL

IN/OUT	PART#
2.25"/2" Dual	13148
3"/2.25" Dual	13278
3"/2.5" Dual	13288

18" CENTER/OFFSET

IN/OUT	PART#
2"	13254
2.25"	13255
2.5"	13256
3"	13259

18" OFFSET/OFFSET

IN/OUT	PART#
2"	13264
2.25"	13265
2.5"	13266
3"	13269

6" ROUND 3 CHAMBER

OFFSET/OFFSET

IN/OUT	BODY LENGTH	OVERALL LENGTH	PART#
2"	18"	24"	13650
2"	22"	28"	13649
2"	27"	33"	13644
2.25"	27"	33"	13645
2.5"	27"	33"	13646

7" ROUND 3 CHAMBER

CENTER/CENTER

IN/OUT	BODY LENGTH	OVERALL LENGTH	PART#
3"	18"	24"	13743
3"	24"	30"	13742
3"	30"	36"	13741
3"	34"	40"	13740

OFFSET/OFFSET

IN/OUT	BODY LENGTH	OVERALL LENGTH	PART#
2.25"	18"	24"	13745
2.25"	27"	33"	13744
2.5"	27"	33"	13746
3"	30"	36"	13749

SINGLE/DUAL

IN/OUT	BODY LENGTH	OVERALL LENGTH	PART#
2.25"/2" Dual	24"	30"	13760
3"/2.5" Dual	24"	30"	13763
2.5"/2.5" Dual	27"	33"	13761
3"/2.5" Dual	30"	36"	13762

CLAMP ON TIPS STAINLESS STEEL CHAMBER

Round Single Wall Turndown

DIA.	LENGTH	INLET	PART#
5"	20"	4"	35187

Round Double Wall Angle Cut

DIA.	LENGTH	INLET	PART#
3.5"	9.5"	2.75"	35210
Fits 2.5" TO 2.75" Tailpipe			
3.5"	9.5"	3"	35211
Fits 2.75" TO 3" Tailpipe			

Round Double Wall Rolled Edge Angle Cut

DIA.	LENGTH	INLET	PART#
5"	13"	4"	35186

Round Single Wall Rolled Edge Angle Cut

DIA.	LENGTH	INLET	PART#
3"	12"	2.5"	35208
Fits 2.25" to 2.5" Tailpipe			
3.5"	12"	2.75"	35209
Fits 2.5" to 2.75" Tailpipe			
4"	12"	3"	35212
Fits 2.75" to 3" Tailpipe			
5"	14.5"	3.5"	35213
Fits 3.5" Tailpipe			
5"	13"	4"	35214
Fits 4" Tailpipe			
6"	13"	5"	35215

Rectangle Single Wall Challenger

DIA.	LENGTH	INLET	PART#
2.375" x 7.75"	5"	2.75"	35221

Round Single Wall Rolled Edge Angle Cut

DIA.	LENGTH	INLET	PART#
5"	14.5"	3.5"	35237
5"	13"	4"	35238
6"	13"	5"	35239

Round Single Wall Intercooled Rolled Edge Angle Cut

DIA.	LENGTH	INLET	PART#
5"	13"	4"	35220

Round Double Wall Rolled Edge Angle Cut

DIA.	LENGTH	INLET	PART#
5"	13"	4"	35240

SPORT COMPACT/EURO - DUAL TIPS/STAINLESS STEEL

Round Double Wall Angle Cut

DIA.	LENGTH	INLET	PART#
3"	8"	2.25"	35226

Round Double Wall Angle Cut DRIVER SIDE

DIA.	LENGTH	INLET	PART#
3"	9.75"	2.25"	35228

Round Double Wall Angle Cut PASSENGER SIDE

DIA.	LENGTH	INLET	PART#
3"	9.75"	2.25"	35227

Round Double Wall Angle Cut DRIVER SIDE | PASSENGER SIDE

DIA.	LENGTH	INLET	PART#
3"	9.75"	2.25"	35229

Sold As Pair

Round Rolled Edge Double Wall Straight Cut

DIA.	LENGTH	INLET	PART#
3"	10"	2.25"	35167
3"	10"	2.25"	35168

Single Wall Angle Cut

Oval Double Wall Rolled Edge Straight Cut

DIA.	LENGTH	INLET	PART#
3"x 3.75"	10"	2.25"	35169

SPORT COMPACT/EURO - DUAL TIPS/STAINLESS STEEL (cont.)

<p>Round Double Wall Rolled Edge Angle Cut</p> <table border="1"> <thead> <tr> <th>DIA.</th> <th>LENGTH</th> <th>INLET</th> <th>PART#</th> </tr> </thead> <tbody> <tr> <td>3"</td> <td>6.75"</td> <td>2.25"</td> <td>35163</td> </tr> </tbody> </table>	DIA.	LENGTH	INLET	PART#	3"	6.75"	2.25"	35163	<p>Round Double Wall Rolled Edge Angle Cut</p> <table border="1"> <thead> <tr> <th>DIA.</th> <th>LENGTH</th> <th>INLET</th> <th>PART#</th> </tr> </thead> <tbody> <tr> <td>4"</td> <td>8.25"</td> <td>2.25"</td> <td>35164</td> </tr> <tr> <td>4"</td> <td>6.25"</td> <td>2.25"</td> <td>35177</td> </tr> </tbody> </table>	DIA.	LENGTH	INLET	PART#	4"	8.25"	2.25"	35164	4"	6.25"	2.25"	35177	<p>Oval Double Wall Resonated Rolled Edge Angle Cut</p> <table border="1"> <thead> <tr> <th>DIA.</th> <th>LENGTH</th> <th>INLET</th> <th>PART#</th> </tr> </thead> <tbody> <tr> <td>3.5"x 4.25"</td> <td>12"</td> <td>2.25"</td> <td>35174</td> </tr> </tbody> </table>	DIA.	LENGTH	INLET	PART#	3.5"x 4.25"	12"	2.25"	35174	<p>Round Double Wall Resonated Rolled Edge Angle Cut</p> <table border="1"> <thead> <tr> <th>DIA.</th> <th>LENGTH</th> <th>INLET</th> <th>PART#</th> </tr> </thead> <tbody> <tr> <td>4"</td> <td>12"</td> <td>2.25"</td> <td>35173</td> </tr> </tbody> </table>	DIA.	LENGTH	INLET	PART#	4"	12"	2.25"	35173																
DIA.	LENGTH	INLET	PART#																																																				
3"	6.75"	2.25"	35163																																																				
DIA.	LENGTH	INLET	PART#																																																				
4"	8.25"	2.25"	35164																																																				
4"	6.25"	2.25"	35177																																																				
DIA.	LENGTH	INLET	PART#																																																				
3.5"x 4.25"	12"	2.25"	35174																																																				
DIA.	LENGTH	INLET	PART#																																																				
4"	12"	2.25"	35173																																																				
<p>Round Double Wall Slash Cut</p> <table border="1"> <thead> <tr> <th>DIA.</th> <th>LENGTH</th> <th>INLET</th> <th>PART#</th> </tr> </thead> <tbody> <tr> <td>3.5"</td> <td>5.5"</td> <td>2.5"</td> <td>35225</td> </tr> </tbody> </table>	DIA.	LENGTH	INLET	PART#	3.5"	5.5"	2.5"	35225	<p>Round Double Wall Slash Cut</p> <table border="1"> <thead> <tr> <th>DIA.</th> <th>LENGTH</th> <th>INLET</th> <th>PART#</th> </tr> </thead> <tbody> <tr> <td>4"</td> <td>7"</td> <td>2.25"</td> <td>35121</td> </tr> </tbody> </table>	DIA.	LENGTH	INLET	PART#	4"	7"	2.25"	35121	<p>Round Double Wall Slash Cut</p> <table border="1"> <thead> <tr> <th>DIA.</th> <th>LENGTH</th> <th>INLET</th> <th>PART#</th> </tr> </thead> <tbody> <tr> <td>4.5"</td> <td>5.75"</td> <td>2.5"</td> <td>35224</td> </tr> </tbody> </table>	DIA.	LENGTH	INLET	PART#	4.5"	5.75"	2.5"	35224	<p>Oval Double Wall Rolled Edge Straight Cut</p> <table border="1"> <thead> <tr> <th>DIA.</th> <th>LENGTH</th> <th>INLET</th> <th>PART#</th> </tr> </thead> <tbody> <tr> <td>3"x 3.75"</td> <td>7.25"</td> <td>2.25"</td> <td>35159</td> </tr> </tbody> </table>	DIA.	LENGTH	INLET	PART#	3"x 3.75"	7.25"	2.25"	35159																				
DIA.	LENGTH	INLET	PART#																																																				
3.5"	5.5"	2.5"	35225																																																				
DIA.	LENGTH	INLET	PART#																																																				
4"	7"	2.25"	35121																																																				
DIA.	LENGTH	INLET	PART#																																																				
4.5"	5.75"	2.5"	35224																																																				
DIA.	LENGTH	INLET	PART#																																																				
3"x 3.75"	7.25"	2.25"	35159																																																				
<p>Round Double Wall Slash Cut</p> <table border="1"> <thead> <tr> <th>DIA.</th> <th>LENGTH</th> <th>INLET</th> <th>PART#</th> </tr> </thead> <tbody> <tr> <td>4"</td> <td>4.5"</td> <td>2.25"</td> <td>35127</td> </tr> </tbody> </table>	DIA.	LENGTH	INLET	PART#	4"	4.5"	2.25"	35127	<p>Round Double Wall Straight Cut</p> <table border="1"> <thead> <tr> <th>DIA.</th> <th>LENGTH</th> <th>INLET</th> <th>PART#</th> </tr> </thead> <tbody> <tr> <td>3"</td> <td>7.5"</td> <td>2.25"</td> <td>35122</td> </tr> <tr> <td>3.5"</td> <td>4.5"</td> <td>2.25"</td> <td>35125</td> </tr> <tr> <td>3.5"</td> <td>7.5"</td> <td>2.25"</td> <td>35123</td> </tr> <tr> <td>4"</td> <td>4.5"</td> <td>2.25"</td> <td>35124</td> </tr> <tr> <td>4"</td> <td>7.5"</td> <td>2.25"</td> <td>35126</td> </tr> </tbody> </table>	DIA.	LENGTH	INLET	PART#	3"	7.5"	2.25"	35122	3.5"	4.5"	2.25"	35125	3.5"	7.5"	2.25"	35123	4"	4.5"	2.25"	35124	4"	7.5"	2.25"	35126	<p>Round Double Wall Slash Cut</p> <table border="1"> <thead> <tr> <th>DIA.</th> <th>LENGTH</th> <th>INLET</th> <th>PART#</th> </tr> </thead> <tbody> <tr> <td>2.5"</td> <td>13"</td> <td>2.75"</td> <td>35179</td> </tr> <tr> <td>3"</td> <td>13"</td> <td>3"</td> <td>35180</td> </tr> </tbody> </table>	DIA.	LENGTH	INLET	PART#	2.5"	13"	2.75"	35179	3"	13"	3"	35180	<p>Oval Double Wall Resonated Slash Cut</p> <table border="1"> <thead> <tr> <th>DIA.</th> <th>LENGTH</th> <th>INLET</th> <th>PART#</th> </tr> </thead> <tbody> <tr> <td>3.25"x 4.5"</td> <td>7"</td> <td>2.25"</td> <td>35158</td> </tr> </tbody> </table>	DIA.	LENGTH	INLET	PART#	3.25"x 4.5"	7"	2.25"	35158
DIA.	LENGTH	INLET	PART#																																																				
4"	4.5"	2.25"	35127																																																				
DIA.	LENGTH	INLET	PART#																																																				
3"	7.5"	2.25"	35122																																																				
3.5"	4.5"	2.25"	35125																																																				
3.5"	7.5"	2.25"	35123																																																				
4"	4.5"	2.25"	35124																																																				
4"	7.5"	2.25"	35126																																																				
DIA.	LENGTH	INLET	PART#																																																				
2.5"	13"	2.75"	35179																																																				
3"	13"	3"	35180																																																				
DIA.	LENGTH	INLET	PART#																																																				
3.25"x 4.5"	7"	2.25"	35158																																																				
<p>Round Single Wall DTM</p> <table border="1"> <thead> <tr> <th>DIA.</th> <th>LENGTH</th> <th>INLET</th> <th>PART#</th> </tr> </thead> <tbody> <tr> <td>2.5"</td> <td>8.25"</td> <td>2.25"</td> <td>35130</td> </tr> <tr> <td>3"</td> <td>8.5"</td> <td>2.25"</td> <td>35133</td> </tr> </tbody> </table>	DIA.	LENGTH	INLET	PART#	2.5"	8.25"	2.25"	35130	3"	8.5"	2.25"	35133	<p>Square Single Wall DTM</p> <table border="1"> <thead> <tr> <th>DIA.</th> <th>LENGTH</th> <th>INLET</th> <th>PART#</th> </tr> </thead> <tbody> <tr> <td>3"</td> <td>8.5"</td> <td>2.25"</td> <td>35135</td> </tr> </tbody> </table>	DIA.	LENGTH	INLET	PART#	3"	8.5"	2.25"	35135	<p>Round Single Wall Rolled Edge Angle Cut</p> <table border="1"> <thead> <tr> <th>DIA.</th> <th>LENGTH</th> <th>INLET</th> <th>PART#</th> </tr> </thead> <tbody> <tr> <td>4"</td> <td>5"</td> <td>2.5"</td> <td>35136</td> </tr> </tbody> </table>	DIA.	LENGTH	INLET	PART#	4"	5"	2.5"	35136	<p>Oval Double Wall Resonated Slash Cut</p> <table border="1"> <thead> <tr> <th>DIA.</th> <th>LENGTH</th> <th>INLET</th> <th>PART#</th> </tr> </thead> <tbody> <tr> <td>3.25"x 4.5"</td> <td>7"</td> <td>2.25"</td> <td>35158</td> </tr> </tbody> </table>	DIA.	LENGTH	INLET	PART#	3.25"x 4.5"	7"	2.25"	35158																
DIA.	LENGTH	INLET	PART#																																																				
2.5"	8.25"	2.25"	35130																																																				
3"	8.5"	2.25"	35133																																																				
DIA.	LENGTH	INLET	PART#																																																				
3"	8.5"	2.25"	35135																																																				
DIA.	LENGTH	INLET	PART#																																																				
4"	5"	2.5"	35136																																																				
DIA.	LENGTH	INLET	PART#																																																				
3.25"x 4.5"	7"	2.25"	35158																																																				
<p>Round Single Wall Rolled Edge Angle Cut</p> <table border="1"> <thead> <tr> <th>DIA.</th> <th>LENGTH</th> <th>INLET</th> <th>PART#</th> </tr> </thead> <tbody> <tr> <td>3"</td> <td>7"</td> <td>2.25"</td> <td>35131</td> </tr> </tbody> </table>	DIA.	LENGTH	INLET	PART#	3"	7"	2.25"	35131	<p>Rectangle Single Wall Rolled Edge Angle Cut</p> <table border="1"> <thead> <tr> <th>DIA.</th> <th>LENGTH</th> <th>INLET</th> <th>PART#</th> </tr> </thead> <tbody> <tr> <td>2.5" x 2.75"</td> <td>7.5"</td> <td>2.25"</td> <td>35134</td> </tr> </tbody> </table>	DIA.	LENGTH	INLET	PART#	2.5" x 2.75"	7.5"	2.25"	35134	<p>Oval Single Wall Rolled Edge Angle Cut</p> <table border="1"> <thead> <tr> <th>DIA.</th> <th>LENGTH</th> <th>INLET</th> <th>PART#</th> </tr> </thead> <tbody> <tr> <td>2.5" x 3.25"</td> <td>7.5"</td> <td>2.25"</td> <td>35129</td> </tr> </tbody> </table>	DIA.	LENGTH	INLET	PART#	2.5" x 3.25"	7.5"	2.25"	35129	<p>Round Double Wall Angle Cut</p> <table border="1"> <thead> <tr> <th>DIA.</th> <th>LENGTH</th> <th>INLET</th> <th>PART#</th> </tr> </thead> <tbody> <tr> <td>4.5"</td> <td>8"</td> <td>2.5"</td> <td>35128</td> </tr> </tbody> </table> <p>Tanabe</p>	DIA.	LENGTH	INLET	PART#	4.5"	8"	2.5"	35128																				
DIA.	LENGTH	INLET	PART#																																																				
3"	7"	2.25"	35131																																																				
DIA.	LENGTH	INLET	PART#																																																				
2.5" x 2.75"	7.5"	2.25"	35134																																																				
DIA.	LENGTH	INLET	PART#																																																				
2.5" x 3.25"	7.5"	2.25"	35129																																																				
DIA.	LENGTH	INLET	PART#																																																				
4.5"	8"	2.5"	35128																																																				

SPORT COMPACT/EURO SPECIALTY TIPS - STAINLESS STEEL

<p>Rectangle Double Wall Rolled Edge Straight Cut</p> <table border="1"> <thead> <tr> <th>DIA.</th> <th>LENGTH</th> <th>INLET</th> <th>PART#</th> </tr> </thead> <tbody> <tr> <td>3" x 3.5"</td> <td>7.25"</td> <td>2.25"</td> <td>35157</td> </tr> </tbody> </table>	DIA.	LENGTH	INLET	PART#	3" x 3.5"	7.25"	2.25"	35157	<p>Oblong Double Wall Rolled Edge Angle Cut</p> <table border="1"> <thead> <tr> <th>DIA.</th> <th>LENGTH</th> <th>INLET</th> <th>PART#</th> </tr> </thead> <tbody> <tr> <td>2.75" x 5.25"</td> <td>7.25"</td> <td>2.25"</td> <td>35175</td> </tr> </tbody> </table>	DIA.	LENGTH	INLET	PART#	2.75" x 5.25"	7.25"	2.25"	35175	<p>Oblong Double Wall Rolled Edge DTM</p> <table border="1"> <thead> <tr> <th>DIA.</th> <th>LENGTH</th> <th>INLET</th> <th>PART#</th> </tr> </thead> <tbody> <tr> <td>2.75" x 5.25"</td> <td>9.75"</td> <td>2.25"</td> <td>35176</td> </tr> </tbody> </table>	DIA.	LENGTH	INLET	PART#	2.75" x 5.25"	9.75"	2.25"	35176
DIA.	LENGTH	INLET	PART#																							
3" x 3.5"	7.25"	2.25"	35157																							
DIA.	LENGTH	INLET	PART#																							
2.75" x 5.25"	7.25"	2.25"	35175																							
DIA.	LENGTH	INLET	PART#																							
2.75" x 5.25"	9.75"	2.25"	35176																							

AMERICAN MUSCLE TIPS - STAINLESS STEEL

<p>Round Single Wall 15° Slash Cut</p> <table border="1"> <thead> <tr> <th>DIA.</th> <th>LENGTH</th> <th>INLET</th> <th>PART#</th> </tr> </thead> <tbody> <tr> <td>3"</td> <td>18"</td> <td>2.5"</td> <td>35102</td> </tr> <tr> <td>3"</td> <td>12"</td> <td>3"</td> <td>35101</td> </tr> <tr> <td>3.5"</td> <td>12"</td> <td>2.5"</td> <td>35205</td> </tr> <tr> <td>3.5"</td> <td>12"</td> <td>3"</td> <td>35104</td> </tr> <tr> <td>3.5"</td> <td>18"</td> <td>2.5"</td> <td>35105</td> </tr> <tr> <td>4"</td> <td>12"</td> <td>3"</td> <td>35107</td> </tr> <tr> <td>4"</td> <td>18"</td> <td>2.5"</td> <td>35108</td> </tr> </tbody> </table>	DIA.	LENGTH	INLET	PART#	3"	18"	2.5"	35102	3"	12"	3"	35101	3.5"	12"	2.5"	35205	3.5"	12"	3"	35104	3.5"	18"	2.5"	35105	4"	12"	3"	35107	4"	18"	2.5"	35108	<p>Round Single Wall 45° Slash Cut</p> <table border="1"> <thead> <tr> <th>DIA.</th> <th>LENGTH</th> <th>INLET</th> <th>PART#</th> </tr> </thead> <tbody> <tr> <td>3"</td> <td>18"</td> <td>2.25"</td> <td>35140</td> </tr> <tr> <td>3"</td> <td>18"</td> <td>2.5"</td> <td>35138</td> </tr> <tr> <td>3.5"</td> <td>18"</td> <td>2.25"</td> <td>35216</td> </tr> <tr> <td>3.5"</td> <td>18"</td> <td>2.5"</td> <td>35143</td> </tr> <tr> <td>4"</td> <td>18"</td> <td>2.5"</td> <td>35146</td> </tr> </tbody> </table>	DIA.	LENGTH	INLET	PART#	3"	18"	2.25"	35140	3"	18"	2.5"	35138	3.5"	18"	2.25"	35216	3.5"	18"	2.5"	35143	4"	18"	2.5"	35146	<p>Round Single Wall 15° Rolled Edge Angle Cut</p> <table border="1"> <thead> <tr> <th>DIA.</th> <th>LENGTH</th> <th>INLET</th> <th>PART#</th> </tr> </thead> <tbody> <tr> <td>3"</td> <td>12"</td> <td>2.5"</td> <td>35204</td> </tr> <tr> <td>3"</td> <td>12"</td> <td>3"</td> <td>35110</td> </tr> <tr> <td>3.5"</td> <td>12"</td> <td>3"</td> <td>35113</td> </tr> <tr> <td>4"</td> <td>12"</td> <td>3"</td> <td>35116</td> </tr> </tbody> </table>	DIA.	LENGTH	INLET	PART#	3"	12"	2.5"	35204	3"	12"	3"	35110	3.5"	12"	3"	35113	4"	12"	3"	35116	<p>Round Single Wall 15° Rolled Edge Angle Cut</p> <table border="1"> <thead> <tr> <th>DIA.</th> <th>LENGTH</th> <th>INLET</th> <th>PART#</th> </tr> </thead> <tbody> <tr> <td>3"</td> <td>18"</td> <td>2.5"</td> <td>35111</td> </tr> <tr> <td>3.5"</td> <td>18"</td> <td>2.25"</td> <td>35217</td> </tr> <tr> <td>3.5"</td> <td>18"</td> <td>2.5"</td> <td>35114</td> </tr> <tr> <td>4"</td> <td>18"</td> <td>2.5"</td> <td>35117</td> </tr> </tbody> </table>	DIA.	LENGTH	INLET	PART#	3"	18"	2.5"	35111	3.5"	18"	2.25"	35217	3.5"	18"	2.5"	35114	4"	18"	2.5"	35117
DIA.	LENGTH	INLET	PART#																																																																																																
3"	18"	2.5"	35102																																																																																																
3"	12"	3"	35101																																																																																																
3.5"	12"	2.5"	35205																																																																																																
3.5"	12"	3"	35104																																																																																																
3.5"	18"	2.5"	35105																																																																																																
4"	12"	3"	35107																																																																																																
4"	18"	2.5"	35108																																																																																																
DIA.	LENGTH	INLET	PART#																																																																																																
3"	18"	2.25"	35140																																																																																																
3"	18"	2.5"	35138																																																																																																
3.5"	18"	2.25"	35216																																																																																																
3.5"	18"	2.5"	35143																																																																																																
4"	18"	2.5"	35146																																																																																																
DIA.	LENGTH	INLET	PART#																																																																																																
3"	12"	2.5"	35204																																																																																																
3"	12"	3"	35110																																																																																																
3.5"	12"	3"	35113																																																																																																
4"	12"	3"	35116																																																																																																
DIA.	LENGTH	INLET	PART#																																																																																																
3"	18"	2.5"	35111																																																																																																
3.5"	18"	2.25"	35217																																																																																																
3.5"	18"	2.5"	35114																																																																																																
4"	18"	2.5"	35117																																																																																																
<p>Round Double Wall Rolled Edge Angle Cut</p> <table border="1"> <thead> <tr> <th>DIA.</th> <th>LENGTH</th> <th>INLET</th> <th>PART#</th> </tr> </thead> <tbody> <tr> <td>3"</td> <td>6.75"</td> <td>2.25"</td> <td>35163</td> </tr> </tbody> </table>	DIA.	LENGTH	INLET	PART#	3"	6.75"	2.25"	35163	<p>Round Double Wall Rolled Edge Angle Cut</p> <table border="1"> <thead> <tr> <th>DIA.</th> <th>LENGTH</th> <th>INLET</th> <th>PART#</th> </tr> </thead> <tbody> <tr> <td>4"</td> <td>8.25"</td> <td>2.25"</td> <td>35164</td> </tr> <tr> <td>4"</td> <td>6.25"</td> <td>2.25"</td> <td>35177</td> </tr> </tbody> </table>	DIA.	LENGTH	INLET	PART#	4"	8.25"	2.25"	35164	4"	6.25"	2.25"	35177	<p>Round Double Wall Resonated Rolled Edge Angle Cut</p> <table border="1"> <thead> <tr> <th>DIA.</th> <th>LENGTH</th> <th>INLET</th> <th>PART#</th> </tr> </thead> <tbody> <tr> <td>4"</td> <td>12"</td> <td>2.25"</td> <td>35173</td> </tr> </tbody> </table>	DIA.	LENGTH	INLET	PART#	4"	12"	2.25"	35173	<p>Oval Double Wall Resonated Rolled Edge Angle Cut</p> <table border="1"> <thead> <tr> <th>DIA.</th> <th>LENGTH</th> <th>INLET</th> <th>PART#</th> </tr> </thead> <tbody> <tr> <td>3.5" x 4.25"</td> <td>12"</td> <td>2.25"</td> <td>35174</td> </tr> </tbody> </table>	DIA.	LENGTH	INLET	PART#	3.5" x 4.25"	12"	2.25"	35174																																																												
DIA.	LENGTH	INLET	PART#																																																																																																
3"	6.75"	2.25"	35163																																																																																																
DIA.	LENGTH	INLET	PART#																																																																																																
4"	8.25"	2.25"	35164																																																																																																
4"	6.25"	2.25"	35177																																																																																																
DIA.	LENGTH	INLET	PART#																																																																																																
4"	12"	2.25"	35173																																																																																																
DIA.	LENGTH	INLET	PART#																																																																																																
3.5" x 4.25"	12"	2.25"	35174																																																																																																
<p>Round Double Wall Slash Cut</p> <table border="1"> <thead> <tr> <th>DIA.</th> <th>LENGTH</th> <th>INLET</th> <th>PART#</th> </tr> </thead> <tbody> <tr> <td>3.5"</td> <td>5.5"</td> <td>2.5"</td> <td>35225</td> </tr> </tbody> </table>	DIA.	LENGTH	INLET	PART#	3.5"	5.5"	2.5"	35225	<p>Round Double Wall Slash Cut</p> <table border="1"> <thead> <tr> <th>DIA.</th> <th>LENGTH</th> <th>INLET</th> <th>PART#</th> </tr> </thead> <tbody> <tr> <td>4"</td> <td>7"</td> <td>2.25"</td> <td>35121</td> </tr> <tr> <td>4"</td> <td>4.5"</td> <td>2.25"</td> <td>35127</td> </tr> </tbody> </table>	DIA.	LENGTH	INLET	PART#	4"	7"	2.25"	35121	4"	4.5"	2.25"	35127	<p>Round Double Wall Slash Cut</p> <table border="1"> <thead> <tr> <th>DIA.</th> <th>LENGTH</th> <th>INLET</th> <th>PART#</th> </tr> </thead> <tbody> <tr> <td>4.5"</td> <td>5.75"</td> <td>2.5"</td> <td>35224</td> </tr> </tbody> </table>	DIA.	LENGTH	INLET	PART#	4.5"	5.75"	2.5"	35224	<p>Round Single Wall 15° Rolled Edge Angle Cut</p> <table border="1"> <thead> <tr> <th>DIA.</th> <th>LENGTH</th> <th>INLET</th> <th>PART#</th> </tr> </thead> <tbody> <tr> <td>4"</td> <td>5"</td> <td>2.5"</td> <td>35136</td> </tr> </tbody> </table>	DIA.	LENGTH	INLET	PART#	4"	5"	2.5"	35136																																																												
DIA.	LENGTH	INLET	PART#																																																																																																
3.5"	5.5"	2.5"	35225																																																																																																
DIA.	LENGTH	INLET	PART#																																																																																																
4"	7"	2.25"	35121																																																																																																
4"	4.5"	2.25"	35127																																																																																																
DIA.	LENGTH	INLET	PART#																																																																																																
4.5"	5.75"	2.5"	35224																																																																																																
DIA.	LENGTH	INLET	PART#																																																																																																
4"	5"	2.5"	35136																																																																																																
<p>Round Double Wall Straight Cut</p> <table border="1"> <thead> <tr> <th>DIA.</th> <th>LENGTH</th> <th>INLET</th> <th>PART#</th> </tr> </thead> <tbody> <tr> <td>4"</td> <td>4.5"</td> <td>2.25"</td> <td>35124</td> </tr> </tbody> </table>	DIA.	LENGTH	INLET	PART#	4"	4.5"	2.25"	35124	<p>Round Double Wall Straight Cut</p> <table border="1"> <thead> <tr> <th>DIA.</th> <th>LENGTH</th> <th>INLET</th> <th>PART#</th> </tr> </thead> <tbody> <tr> <td>3"</td> <td>7.5"</td> <td>2.25"</td> <td>35122</td> </tr> <tr> <td>3.5"</td> <td>7.5"</td> <td>2.25"</td> <td>35123</td> </tr> <tr> <td>3.5"</td> <td>4.5"</td> <td>2.25"</td> <td>35125</td> </tr> <tr> <td>4"</td> <td>7.5"</td> <td>2.25"</td> <td>35126</td> </tr> </tbody> </table>	DIA.	LENGTH	INLET	PART#	3"	7.5"	2.25"	35122	3.5"	7.5"	2.25"	35123	3.5"	4.5"	2.25"	35125	4"	7.5"	2.25"	35126	<p>Round Double Wall 15° Rolled Edge Angle Cut</p> <table border="1"> <thead> <tr> <th>DIA.</th> <th>LENGTH</th> <th>INLET</th> <th>PART#</th> </tr> </thead> <tbody> <tr> <td>3.5"</td> <td>10"</td> <td>2.5"</td> <td>35190</td> </tr> </tbody> </table>	DIA.	LENGTH	INLET	PART#	3.5"	10"	2.5"	35190																																																													
DIA.	LENGTH	INLET	PART#																																																																																																
4"	4.5"	2.25"	35124																																																																																																
DIA.	LENGTH	INLET	PART#																																																																																																
3"	7.5"	2.25"	35122																																																																																																
3.5"	7.5"	2.25"	35123																																																																																																
3.5"	4.5"	2.25"	35125																																																																																																
4"	7.5"	2.25"	35126																																																																																																
DIA.	LENGTH	INLET	PART#																																																																																																
3.5"	10"	2.5"	35190																																																																																																

AMERICAN MUSCLE DUAL TIPS - STAINLESS STEEL

Round Double Wall Angle Cut

DIA.	LENGTH	INLET	PART#
3"	8"	2.25"	35226

Round Double Wall Angle Cut

DIA.	LENGTH	INLET	PART#
3"	9.75"	2.25"	35228

Round Double Wall Angle Cut

DIA.	LENGTH	INLET	PART#
3"	9.75"	2.25"	35227

Round Double Wall Rolled Edge Straight Cut

DIA.	LENGTH	INLET	PART#
3"	10"	2.25"	35167

Round Double Wall Angle Cut

**Sold As Pair*

DIA.	LENGTH	INLET	PART#
3"	9.75"	2.25"	35229

AMERICAN MUSCLE SPECIALTY TIPS - STAINLESS STEEL

Rectangle Single Wall Camaro

DIA.	LENGTH	INLET	PART#
2" x 8"	11"	2.25"	35150

Round Single Wall Turndown

**Sold As Pair*

DIA.	LENGTH	INLET	PART#
2.25"	12.5"	2.5"	35218

Rectangle Single Wall Challenger

DIA.	LENGTH	INLET	PART#
2.375" x 7.25"	5"	2.75"	35221

DIESEL TIPS - STAINLESS STEEL

Round Single Wall Rolled Edge Angle Cut

DIA.	LENGTH	INLET	PART#
5"	13"	4"	35120
5"	8"	4"	35148
6"	13"	5"	35185

Round Double Wall Rolled Edge Angle Cut

DIA.	LENGTH	INLET	PART#
5"	13"	4"	35231
4.5"	12"	3.5"	35232
6"	13"	5"	35233

Round Single Wall Rolled Edge Angle Cut

DIA.	LENGTH	INLET	PART#
5"	24"	4"	35149

Clamp-On Round Double Wall Rolled Edge Angle Cut

DIA.	LENGTH	INLET	PART#
5"	13"	4"	35186

Clamp-On Round Single Wall Rolled Edge Angle Cut

DIA.	LENGTH	INLET	PART#
5"	14.5"	3.5"	35237
5"	13"	4"	35238
6"	13"	5"	35239

Clamp-On Round Single Wall Intercooled Rolled Edge Angle Cut

DIA.	LENGTH	INLET	PART#
5"	13"	4"	35220

Clamp-On Round Single Wall Rolled Edge Angle Cut

DIA.	LENGTH	INLET	PART#
4"	12"	3"	35212
5"	14.5"	3.5"	35213
<i>Fits 3.5" Tailpipe</i>			
5"	13"	4"	35214
6"	13"	5"	35215

DIESEL TIPS - STAINLESS STEEL (cont.)

Clamp-On Round Single Wall Turndown

DIA.	LENGTH	INLET	PART#
5"	20"	4"	35187

Round Single Wall Turndown

DIA.	LENGTH	INLET	PART#
3.5"	16"	3.5"	35178
4"	16"	4"	35181
5"	20"	4"	35188

Round Single Wall 8" Radius

DIA.	LENGTH	INLET	PART#
4"	18"	3"	35182
5"	18"	4"	35183

TRUCK & SUV TIPS - STAINLESS STEEL

Round Single Wall 15° Slash Cut

DIA.	LENGTH	INLET	PART#
3"	12"	3"	35101
3"	18"	2.5"	35102
3"	22"	2.5"	35103
3.5"	12"	2.5"	35205
3.5"	12"	3"	35104
3.5"	18"	2.5"	35105
3.5"	22"	2.5"	35106
4"	12"	3"	35107
4"	18"	2.5"	35108
4"	22"	2.5"	35109

Round Single Wall 45° Slash Cut

DIA.	LENGTH	INLET	PART#
3"	18"	2.25"	35140
3"	18"	2.5"	35138
3"	22"	2.25"	35141
3"	22"	2.5"	35139
3.5"	18"	2.25"	35216
3.5"	18"	2.5"	35143
3.5"	22"	2.5"	35144
4"	18"	2.5"	35146
4"	22"	2.5"	35147

Round Single Wall 15° Rolled Edge Angle Cut

DIA.	LENGTH	INLET	PART#
3"	12"	2.5"	35204
3"	12"	3"	35110
3"	18"	2.5"	35111
3"	22"	2.5"	35112
3.5"	12"	3"	35113
3.5"	18"	2.25"	35217
3.5"	18"	2.5"	35114
3.5"	22"	2.5"	35115
4"	12"	3"	35116
4"	18"	2.5"	35117
4"	22"	2.5"	35119

Oval Double Wall Rolled Edge Angle Cut

DIA.	LENGTH	INLET	PART#
3.25" x 4.25"	8.25"	3"	35171

Round Double Wall Angle Cut

DIA.	LENGTH	INLET	PART#
3.5"	9.5"	3"	35206

Clamp-On Round Double Wall 15° Rolled Edge Angle Cut

DIA.	LENGTH	INLET	PART#
3.5"	12"	2.75"	35209

Clamp-On Round Double Wall Angle Cut

DIA.	LENGTH	INLET	PART#
3.5"	9.5"	2.75"	35210
3.5"	9.5"	3"	35211

Clamp-On Round Single Wall Rolled Edge Angle Cut

DIA.	LENGTH	INLET	PART#
3"	12"	2.5"	35208

Round Single Wall Clamp-On Rolled Edge Angle Cut

DIA.	LENGTH	INLET	PART#
4"	12"	3"	35236
3"	12"	2.5"	35234
3.5"	12"	2.75"	35235

TIP ADAPTERS - STAINLESS STEEL

STAINLESS

INLET	OUTLET	OVERALL LENGTH	PART#
2.75"	4"	7"	10763
3"	4"	7"	10764

STAINLESS

INLET	OUTLET	OVERALL LENGTH	PART#
3.5"	4"	7"	10765

STAINLESS

INLET	OUTLET	OVERALL LENGTH	PART#
3"	5"	7"	10766

STAINLESS

INLET	OUTLET	OVERALL LENGTH	PART#
3.5"	5"	7"	10767
4"	5"	7"	10769

X/H PIPES - STAINLESS STEEL

CROSSOVER X PIPE TRANSITION

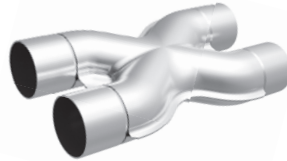

INLET I.D.	OUTLET I.D.	LENGTH	PART#
2.25"	2.25"	12"	10790
2.5"	2.5"	12"	10791
3"	3"	14"	10792

X PIPE TRANSITION



INLET I.D.	OUTLET I.D.	LENGTH	PART#
2.25"	2.25"	9.5"	10780
2.5"	2.5"	9.5"	10781
3"	3"	11.25"	10782

Y/U PIPES - STAINLESS STEEL

Y-PIPE TRANSITION



INLET I.D.	OUTLET I.D.	LENGTH	PART#
2.5" Single	2" Dual	8"	10735
2.5" Single	2.5" Dual	8.5"	10733

Y-PIPE TRANSITION



INLET I.D.	OUTLET I.D.	PART#
2.5" Single	2.5" Dual	10734

Y PIPE TRANSITION



INLET I.D.	OUTLET I.D.	LENGTH	PART#
2.5" Single	2" Dual	10"	10748
2.5" Single	2.25" Dual	10"	10758
2.5" Single	2.5" Dual	10"	10768
3" Single	2.5" Dual	10"	10778
3" Single	3" Dual	10.25"	10798

GIANT 4" Y-PIPE



INLET I.D.	OUTLET I.D.	LENGTH	PART#
3.5" Single	4" Dual	13"	10800
4" Single	4" Dual	13"	10799

90° INLET Y-PIPE



INLET I.D.	OUTLET I.D.	LENGTH	PART#
2.5" Single	2.5" Dual	9"	10732

U-PIPE TRANSITION



INLET I.D.	OUTLET I.D.	PART#
2.5"	2.5"	10731

CLAMPS - STAINLESS STEEL

V-Band Clamp



DIAMETER	PART#
2.5"	10168
3"	10169
3.5"	10170

Band Clamp



DIAMETER	10-PACK PART#	DIAMETER	10-PACK PART#
2"	10160	3"	10164
2.25"	10161	3.5"	10165
2.5"	10162	4"	10166
2.75"	10163	5"	10167

EXHAUST CUT-OUT UNIVERSAL BALL FLANGES

EXHAUST CUT OUT



INLET I.D.	OUTLET I.D.	LENGTH	PART#
2.25"	2.25"	10"	10783
2.5"	2.5"	10"	10784
3"	3"	10"	10785

UNIVERSAL BALL FLANGES



INLET I.D.	OUTLET I.D.	PART#
2.25"	2.25"	10743
2.5"	2.5"	10744

UNIVERSAL BALL FLANGES



INLET I.D.	OUTLET I.D.	PART#
3"	3"	10745

HANGERS - STAINLESS STEEL

STRAIGHT



DIAMETER	LENGTH	10-PACK PART#
.375"	12"	10150
.5"	12"	10151

90° BEND



DIAMETER	LENGTH	10-PACK PART#
.375"	10"	10152
.5"	10"	10153

HEADER MERGE COLLECTORS - STAINLESS STEEL

STAINLESS



INLET	OUTLET	PART#
1.75"	2.5"	10801

STAINLESS



INLET	OUTLET	PART#
1.75"	3"	10802

STAINLESS



INLET	OUTLET	PART#
2"	3"	10803

STAINLESS



INLET	OUTLET	PART#
2"	3.5"	10804

TIP ADAPTERS - STAINLESS STEEL

STAINLESS

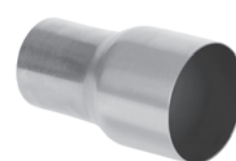

INLET	OUTLET	OVERALL LENGTH	PART#
2.75"	4"	7"	10763
3"	4"	7"	10764

STAINLESS

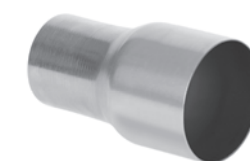

INLET	OUTLET	OVERALL LENGTH	PART#
3.5"	4"	7"	10765

STAINLESS



INLET	OUTLET	OVERALL LENGTH	PART#
3"	5"	7"	10766

STAINLESS

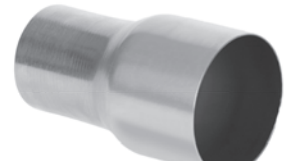

INLET	OUTLET	OVERALL LENGTH	PART#
3.5"	5"	7"	10767
4"	5"	7"	10769

PIPE BENDS - STAINLESS STEEL

90° L-BEND



INLET/OUTLET O.D.	CENTERLINE RADIUS	SINGLE PART #	10-PACK PART#
2.5"	3.5"	10706	10720
3"	5"	10709	10721

180° J-BEND



INLET/OUTLET O.D.	CENTERLINE RADIUS	SINGLE PART #	10-PACK PART#
2.5"	3.5"	10716	10722
3"	5"	10719	10723

45° BEND PIPE



INLET/OUTLET O.D.	CENTERLINE RADIUS	SINGLE PART #	10-PACK PART#
2.5"	3.5"	10736	10724
3"	5"	10739	10725

3-IN-1 PIPE



INLET/OUTLET O.D.	SINGLE PART #	10-PACK PART#
2.25"	10740	10760
2.5"	10741	10761
3"	10742	10762

CUSTOM BUILDERS KIT - STAINLESS STEEL

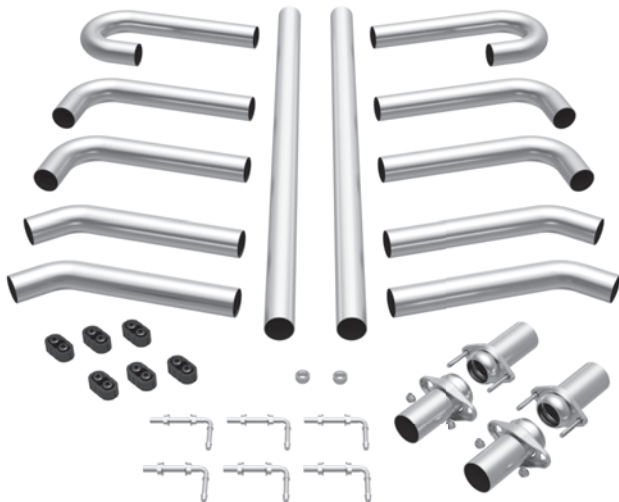

IN/OUT	PART #
2.25"	10701
2.5"	10702
3"	10703