



1978 **40** YEARS 2018

The central text '40 YEARS' is rendered in a large, bold, red font. The number '40' is significantly larger than the word 'YEARS', which is written vertically to its right. The years '1978' and '2018' are placed on either side of the '40' in a white, bold, sans-serif font.

OVAL TRACK CATALOG

The text 'OVAL TRACK CATALOG' is written in a white, italicized, sans-serif font, centered below the '40 YEARS' text.

KSE-RACING

The text 'KSE-RACING' is written in a white, italicized, sans-serif font at the bottom left of the page.

About KSE Racing Products, Inc.

KSE Racing Products has changed quite a bit since its inception nearly forty years ago, but we have remained true to our beginnings in American grassroots racing. Now operating out of our state-of-the-art manufacturing facility just north of Nashville, Tennessee we continue our commitment to producing the highest quality pumps and power steering gears in the racing industry.

KSE was originally formed in Northwest Iowa by racers who were addressing their own need for better pumps in their sprint cars. The first pump designed in 1978 was a sprint car power steering pump and its ingenuity caught the attention of many racers and companies. From that point, KSE Racing Products grew into an organization specializing in the engineering, design, and manufacturing of high performance, fluid-power based products including power steering pumps, steering gears, water pumps, and tandem pumps (power steering & fuel).

KSE Racing Products works very closely with its respected dealer network for product distribution and has grown to over 150 dealers worldwide, including Canada, Australia, and New Zealand. We currently feel the best way to service and supply the racer is through local dealers - who help provide the personalized attention each racer deserves.

KSE Racing Products' long-term strategy is to expand and strengthen its market presence through continual development of new and improved products that help to better meet the needs of today's racers. We will continue our commitment to quality, technology, service, and timely delivery which we credit to our success and growth. As always, we take great pride in the quality of our products and strive to produce the *finest racing products at the fairest prices.*

Make sure to look out for several additional new products from KSE & best of luck in 2018!

We Steer The Best From East To West!



KSE Racing Products



State-of-the-art CNC Machining



Steering Gear Production

Cover Photos Credit: TSR, NARC, Vintage Sprint Photos, WRG / DirtCar

Contents



Steering Gears 4



Tandem Pumps (PS/Fuel) 12



Pulleys & Drive Kits 16



Power Steering Pumps 18



Water Pumps & Front Covers 20



Fluids & Accessories 24



Services 25

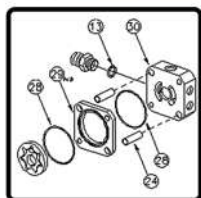

Technical Information 26

STEERING GEARS

TANDEM PUMPS

PULLEYS & DRIVE KITS

POWER STEERING PUMPS

WATER PUMPS & FRONT COVERS

FLUIDS & ACCESSORIES

SERVICES

TECHNICAL INFO

Gen2 Steering Gears

The Gen2 power steering gear was the product of years of R&D and has helped revolutionize the sprint car steering system with its integral reservoir and in-board mount design. Since its initial release, the Gen2 has quickly become the sprint car industry's most widely used power steering system and is the **trusted choice of America's top drivers and premier race teams including...** Donny Schatz, Chad Kemenah, Kyle Hirst, Greg Hodnett, David Gravel, Brad Sweet, Danny Dietrich, Tanner Thorson, Aaron Reutzel, Sam Hafertepe Jr., Darren Hagen, Bud Kaeding and the list goes on. The results undoubtedly speak for themselves!

Built-in Reservoir

The reservoir is built into the live hub tube of the gear. This design eliminates turbulence, aeration, and provides superior system cooling. The easy-fill 2" vented cap includes a built-in dipstick.

Positive, More Consistent Feel

The four-degree valve and 20% faster lead ball screw helps increase torque output capability and transfers quicker front wheel feedback to the hydraulic assist to improve front wheel stability. The inboard mount improves steering gear mount rigidity, which reduces the rotation of the gear in the chassis and eliminates binding due to chassis flex.

Improved Durability

Solid-model design and FEA analysis were utilized to design a stronger formed casting. The cross shaft tooth form is 40% stronger. The inboard mount eliminates the gear as a structural member of the chassis.

Less Weight

The Gen2 is one of the lightest steering gears currently on the market!

Simplified Plumbing

A -10 line from the built-in reservoir to the pump inlet, and a -6 pressure line from the pump to the pressure port is all that is needed. The return to the reservoir is internally ported. The Gen2 also has standard -4 ORB wing slider ports

Easier and Cleaner Installation

The inboard mount makes installation and removal quicker and easier. It also improves leg-room and minimizes throttle linkage issues. The built-in reservoir and internal plumbing eliminating hoses, fittings and a remote-mounted reservoir. The built-in wing slider ports eliminate the need for additional fittings and hoses.

Value

The industry-leading Gen2 is priced comparable to the previous standard KSE gear with a dead-tube reservoir. All-in-all, the outstanding quality, durability, and the extras add up to an amazing value



**The Results
Champions
Can Love!**



**Donny Schatz
2017 World of Outlaws
Champion**



**Chad Kemenah
2017 All Star Circuit
of Champions**



**Sam Hafertepe Jr.
2017 ASCS Sprint
Champion**



**Inboard Mount Design
Improved Durability &
Knee Room!**

Photos Courtesy of TSR and Hunter Racing.

BLACK SERIES

Back in Black! The Black Series Gen2 is the hottest steering gear in the sprint car market and has helped numerous drivers win National and Track Championships including **Donny Schatz - 2017 World of Outlaws & Knoxville Nationals Champion, Chad Kemenah - 2017 All Star Circuit of Champion, Sam Hafertepe Jr. - 2017 ASCS National Champion, Bud Kaeding - 2017 King of the West / NARC Champion.**

Sleek, Black Anodized Finish

The Black Series Gen2 utilizes black anodized finish on all billet components and a black hardcoat finish on the center section and reservoir casting for the utmost in a sleek, clean look for your car's cockpit.

Lightweight Design

The Black Series Gen2 utilizes a strong, gun-drilled cross shaft assembly which helps reduce the total weight of the steering gear by over a pound. A billet aluminum pitman arm retainer threads directly into the end of the gun-drilled cross shaft.

Durability

The Black Series Gen2 has the exacting quality and durability as the original Gen2 which racers have come to trust.



Lightweight, durable, gun-drilled cross shaft assembly reduces total steering gear weight by over a pound!

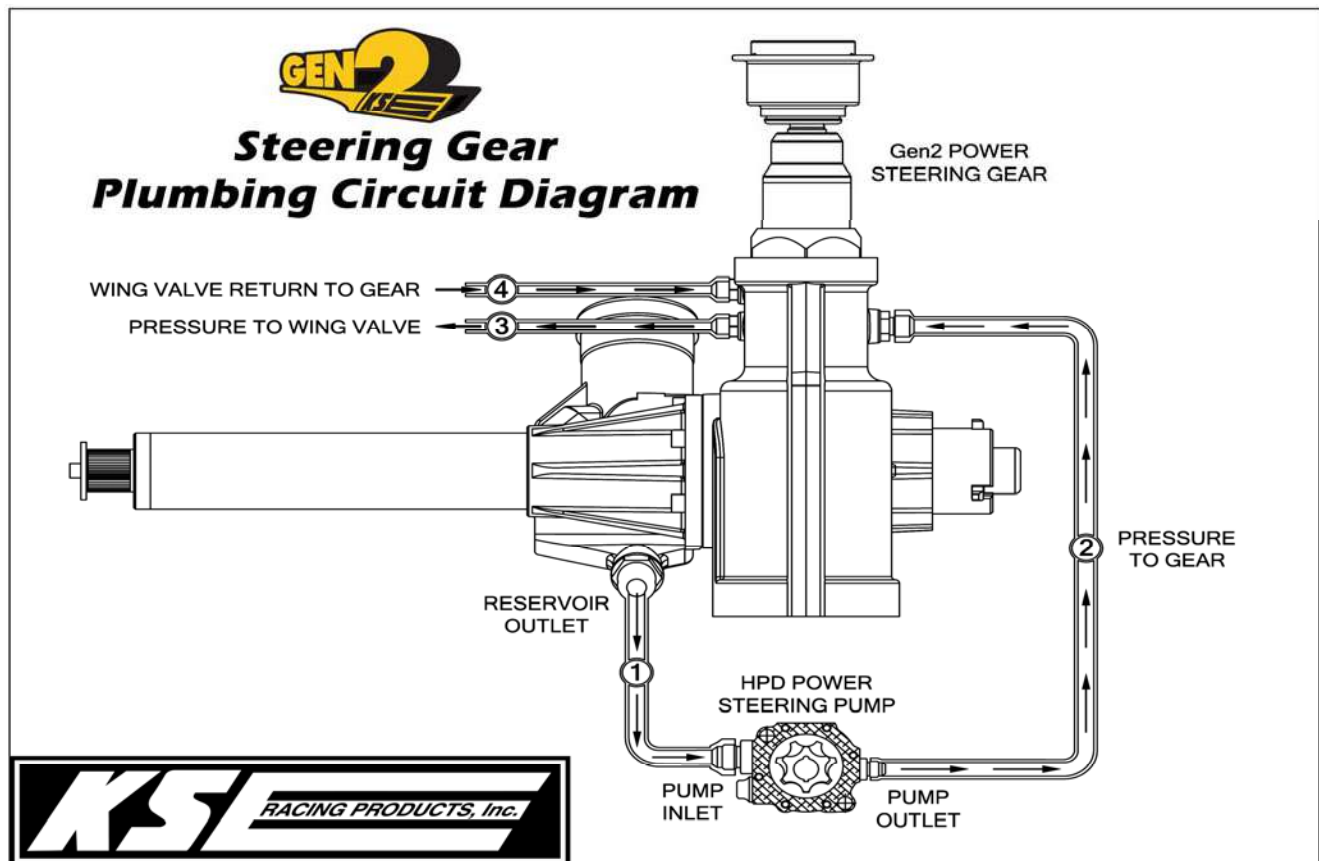

STEERING GEARS

TANDEM PUMPS

PULLEYS & DRIVE KITS

POWER STEERING PUMPS

WATER PUMPS & FRONT COVERS

FLUIDS & ACCESSORIES

SERVICES

TECHNICAL INFO

Gen2 Steering Gears

How to Order:

Create the part number of the gear you need by selecting the desired options in the boxes below and insert their code number into the part number.

Example:

KSGEN2L-5652 is a left-hand gear with 11" input shaft, 16" output shaft, a "35" servo valve, and a pull-type quick release.

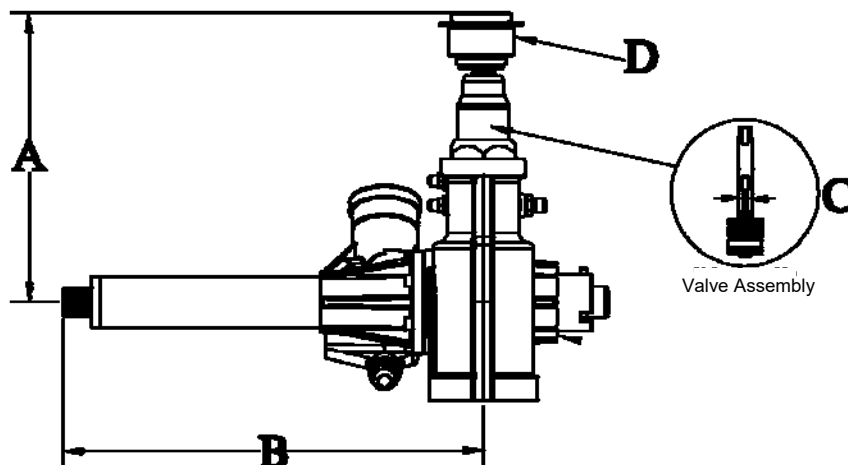

KSGEN2L-

"A" Input Shaft Code	"B" Live Tube Output Shaft Code	"C" Servo Valve Effort Code	"D" Steering Wheel Hub Release Code	"E" Optional Black Series
3 = 10" 5 = 11"	4 = 14" 6 = 16" 8 = 18"	4 = "20" (Easy) 5 = "35" 6 = "40" 7 = "50" 8 = "65" (Firm)	0 = No Quick Release 2 = Pull-Type Quick Release	Add "B" To End Of Part Number For Black Series <i>*Standard Leave Blank</i>

"A" Input Shaft

- Measurement is made from the steering wheel mounting surface of the quick release hub to the center line of the output shaft.
- Input shaft length is based upon driver preference: 11" is the most common in sprint cars, 10" is the most common in midgets, and 12" is common in east coast modified applications.

"B" Live Tube Output Shaft

- Dimension is determined by chassis width, as well as the desired location of the drag link.
- 14" is common left side Midget lengths.
- 16" and 18" are common left side Sprint and Silver Crown lengths. 16" with the wide angle broached pitman arm are used to maximize weight reduction.
- 18" is common for east coast modified applications.

"C" Servo Valve Effort

- The servo valve torsion bar determines the effort required to steer by the driver. This is a driver preference. All KSE gears have the torsion bar size stamped on the web side of the case, next to the serial number.
- A "20" is the least effort size, and a "65" requires the most effort.
- Dirt sprint car drivers generally choose the lower efforts (35-40), while midgets and pavement drivers choose higher efforts (40-50). East coast modifieds typically are (20) effort.

NEW AND DEVELOPING DRIVERS

The Gen2 is a great steering system for young and developing drivers starting out. KSE recommends evaluating a steering gear with a shorter input (10") and the smallest servo valve torsion bar ("20").

WAIVER WARRANTY (EXPRESSED OR IMPLIED) NO GUARANTEE

This product and each part thereof, is sold "AS IS" and with all faults. KSE Racing Products, Inc will not be liable for any loss, damage, or injury arising from the use of this product. RACING IS A DANGEROUS ACTIVITY. The user shall determine the suitability and safety of the product for its intended use, and the user assumes all responsibility and risk in connection therewith.

Parts & Accessories

Stingray

The Stingray Wing Valve & Cylinder are utilized by the country's top sprint car drivers & teams including Donny Schatz and Jason Johnson



Sleek handle design & lightweight, all billet construction!

KSG2000

Stingray Wing Slider Valve

Stingray Wing Valve Product Features

- Lightweight all billet aluminum design
- Flow performance matched to entire power steering system
- Ergonomic handle design
- Precision seal design & 100% tested



KSG2001-010

Stingray Wing Cylinder - 10"

KSG2001-008

Stingray Wing Cylinder - 8"

Stingray Wing Cylinder Product Features

- High quality, all billet design with anodized finish
- True hydraulic wing cylinder - 1300 psi rated
- Precision quad seal, spherical bearing, 1/8 NPT ports



KSG2007

Rebuild Kit For Stingray Wing Cylinder - 10"



KSG1027

NEW DESIGN!

High Quality Aluminum Pull-Type Quick Release Hub



KSM6002

#3 ORB to #4 JIC High-Flow Wing Slider Fitting for Gen2 Steering Gear



KSG1070

Lightweight Billet Aluminum Inboard Mounting Bracket



Steering Gear Seal Kit

KSG0032 (First Gen Gear)

KSG0035 (Gen2 Gear)



KSG1071

Weld-In Mounting Tabs for KSG1070



KSM6001

#3 ORB Wing Port Plug

STEERING GEARS

TANDEM PUMPS

PULLEYS & DRIVE KITS

POWER STEERING PUMPS

WATER PUMPS & FRONT COVERS

FLUIDS & ACCESSORIES

SERVICES

TECHNICAL INFO

Right Side Steering Gears

How to Order:

Create the part number of the gear you need by selecting the desired options in the boxes below and insert their code number into the part number.

Example:

KSG 11-59872 is a standard right-side gear with 11" input shaft, 18" output shaft with live tube reservoir, a "65" servo valve, 13" dead tube, and a pull-type quick release.

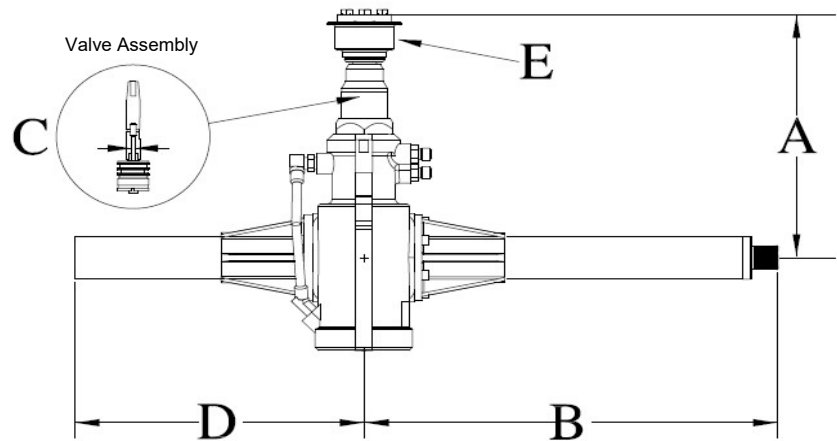

Gear Type Code	"A" Input Shaft Code	"B" Live Tube Output Shaft Code	"C" Servo Valve Effort Code	"D" Dead Tube Code	"E" Steering Wheel Hub Release
11 = Standard Right Side 12 = 12:1 Ratio Right Side	3 = 10" 5 = 11"	4 = 14" 5 = 14" Res. 6 = 16" 7 = 16" Res. 8 = 18" 9 = 18" Res.	4 = "20" (Easy) 5 = "35" 6 = "40" 7 = "50" 8 = "65" (Firm)	0 = Center Mt. 3 = 11" Res. 4 = 12" 5 = 11.5" Res. 7 = 13" 8 = 14.5" 9 = 13" Res.	0 = No Quick Release 2 = Pull-Type Quick Release

Please inquire about custom gears and additional options that may be available upon request.

"A" Input Shaft

- Measurement is made from the steering wheel mounting surface of the quick release hub to the center line of the output shaft.
- Input shaft length is based upon driver preference.

"B" Live Tube Output Shaft

- Dimension is determined by chassis width, as well as the desired location of the drag link.
- 18" is the most common length for right side Sprints and Midgets.
- Live Tube Reservoirs are available for all lengths as indicated and allow for superior cooling of the power steering fluid.

"C" Servo Valve Effort

- The servo valve torsion bar determines the effort required to steer by the driver. This is a driver preference. All KSE gears have the torsion bar size stamped on the web side of the case, next to the serial number.
- A "20" is the least effort size, and a "65" requires the most effort.
- Midget and Pavement Sprint drivers generally chose firmer efforts with "50" and "65" being the most common.

"D" Dead Tube

- Dimension is determined by chassis width, as well as location of the mounting bracket.
- 13" is the most common length for right side Sprints and Midgets.
- Dead Tube Reservoirs are available for several lengths as indicated.

Right Side Steering Gears



Precision & Performance

KSE's pavement right side drive power steering gears are utilized by some of the nations top pavement sprint car drivers. With various servo valve efforts available, the driver has the ability to build a customized gear to suit the feel of the car and application.

KSE's Right Side Drive Power Steering Gears are designed and built with the racer in mind. By offering various options, the steering gear can be tailored to racers who demand the precision which is key for any open wheel pavement race car.

KSE's steering gears can be built in either a standard 9:1 ratio or in a newer 12:1 ratio version. The new 12:1 ratio allows drivers to be smoother and more consistent. This is a MUST for fast, high-bank tracks.

The steering gears can be equipped with optional reservoirs which are built in to either the dead tube or live tube assemblies. The live tube reservoir design helps to eliminate turbulence, aeration, and helps to provide superior cooling to externally mounted reservoirs. The easy-fill 2" diameter cap is vented and has a built-in dipstick.

The wing slider ports are o-ring sealed. Special high-flow #3 o-ring boss to 37-degree JIC #4 fittings are available.



Jimmy McCune
2017 Must See Racing
Sprint Series Champion

WAIVER WARRANTY (EXPRESSED OR IMPLIED) NO GUARANTEE

This product and each part thereof, is sold "AS IS" and with all faults. KSE Racing Products, Inc will not be liable for any loss, damage, or injury arising from the use of this product. RACING IS A DANGEROUS ACTIVITY. The user shall determine the suitability and safety of the product for its intended use, and the user assumes all responsibility and risk in connection therewith.

Sportsman Steering Gears

700 Series Fast Ratio Sportsman Steering Box

KSE Racing Products' new fast ratio 700 Series Sportsman steering box was developed to help simplify and improve performance of current circle track steering systems. The new steering box features an OE remanufactured 3-bolt housing, anodized billet aluminum side cover and bottom plate, and refinished internal rack piston / screw assembly with optional 6:1 or 8:1 ratios available.

Positive, More Consistent Feel

Designed to eliminate the need for steering quickeners and additional steering column u-joints, the new steering box provides increased driver response and improved track feedback. With tuned servo valve / torsion bar combinations and 100% performance dyno testing by KSE's steering experts, our high quality steering boxes are built to provide the racer with positive, more consistent feel.

Product Features & Benefits

- New 6:1 Ratio or 8:1 Ratio Precision Internal Components
- Remanufactured and Zinc Finished OE 3-Bolt Housing
- Anodized Billet Aluminum Side Cover & Bottom Plate
- Tuned Servo Valve & Torsion Bar Combinations
- Stub Input Spline Available In 3/4"-30 or 13/16"-36
- -6 JIC Hydraulic Fittings Included
- 100% Performance Dyno Tested
- Manufactured & Built In The USA

KSE 700 Series Sportsman Steering Box Ordering Info:

KSG7061-185

700 Series Sportsman Steering Box
6:1 Ratio - 13/16"-36 Input Spline
185 Torsion Bar (Standard Servo Valve Effort)

KSG7062-185

700 Series Sportsman Steering Box
6:1 Ratio - 3/4"-30 Input Spline
185 Torsion Bar (Standard Servo Valve Effort)

KSG7061-210

700 Series Sportsman Steering Box
6:1 Ratio - 13/16"-36 Input Spline
210 Torsion Bar (Medium Servo Valve Effort)

KSG7062-210

700 Series Sportsman Steering Box
6:1 Ratio - 3/4"-30 Input Spline
210 Torsion Bar (Medium Servo Valve Effort)

KSG7081-210

700 Series Sportsman Steering Box
8:1 Ratio - 13/16"-36 Input Spline
210 Torsion Bar (Standard Servo Valve Effort)

KSG7082-210

700 Series Sportsman Steering Box
8:1 Ratio - 3/4"-30 Input Spline
210 Torsion Bar (Standard Servo Valve Effort)

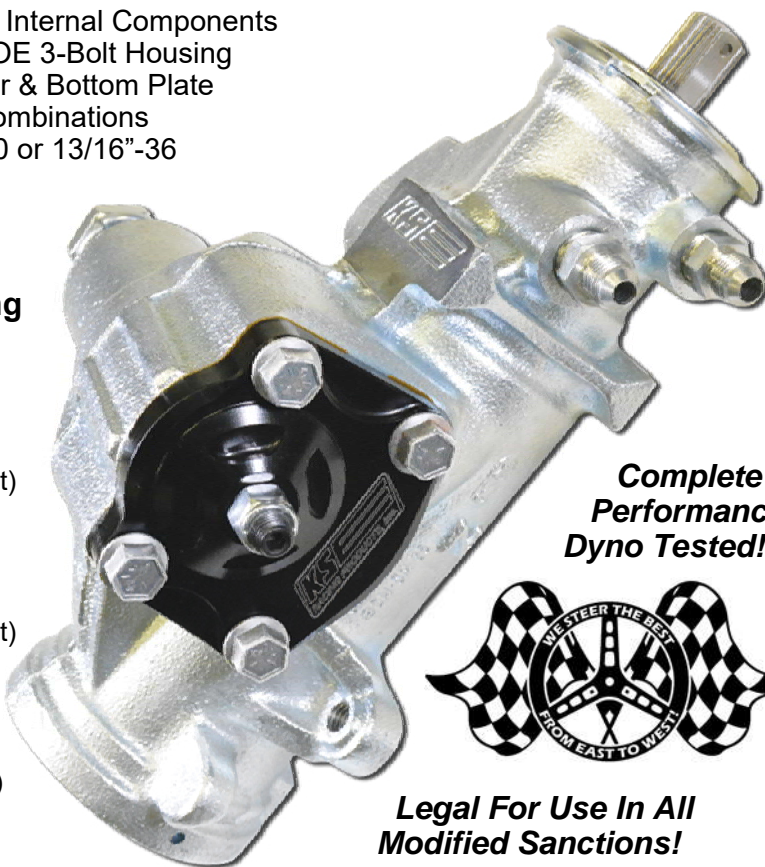

**Complete
Performance
Dyno Tested!**



**Legal For Use In All
Modified Sanctions!**



MHR Photo

**Mike Harrison - 2017 UMP Modified
National Champion**

***Additional torsion bar and servo valve combinations available by custom order. Please contact us to discuss your specific steering application and for additional ordering details and info.**

Sportsman Steering Gears

**New! Save Weight
Where It Matters!**



700 Series Lightweight Steering Box
KSE Racing Products' new lightweight, fast ratio 700 Series steering box was developed to help improve steering performance while also reducing the overall weight by 5 lbs over a standard steering box.

Save Weight Without Compromise of Durability

The new steering box features a precision, fully CNC profiled OE 3-bolt housing, contrast cut anodized billet aluminum side cover and bottom plate, and lightened internal rack piston / screw assembly. With the same tuned servo valve / torsion bar combinations as our standard steering boxes and 100% performance dyno testing by KSE's steering experts, our high quality steering boxes are built to provide the racer with positive, more consistent feel while giving the nose of your racecar a little diet.

These lightweight steering boxes are OE based & are legal in many open racing series - check with your sanction first.

KSE 700 Series Lightweight Steering Box Ordering Info*:
**Additional torsion bar / servo valve combinations available*

KSG7061-185LW

700 Series LW Steering Box
6:1 Ratio - 13/16"-36 Input
185 Torsion Bar (Standard)

KSG7061-210LW

700 Series LW Steering Box
6:1 Ratio - 13/16"-36 Input
185 Torsion Bar (Med Effort)

KSG7081-210LW

700 Series LW Steering Box
8:1 Ratio - 13/16"-36 Input
210 Torsion Bar (Standard)

KSG7062-185LW

700 Series LW Steering Box
6:1 Ratio - 3/4"-30 Input
185 Torsion Bar (Standard)

KSG7062-210LW

700 Series LW Steering Box
6:1 Ratio - 3/4"-30 Input
185 Torsion Bar (Med Effort)

KSG7082-210LW

700 Series LW Steering Box
8:1 Ratio - 3/4"-30 Input
210 Torsion Bar (Standard)

Steering Parts & Accessories



KSM7005

-6 AN Fitting
18mm x 1.5mm O-Ring



KSM7006

-6 AN Fitting
16mm x 1.5mm O-Ring



**All Of KSE's Performance
Steering Products Are
Backed By Industry
Leading Technical
Support & Service!**

Tandem Pumps



Performance and Simplicity

The TandemX Pump is based upon the design of its popular predecessor and is a highly developed "two-in-one" high performance power steering & fuel pump. This pump has been designed to help simplify the racer's engine setup and plumbing while providing the utmost in performance and durability.



Typical SBC Front Drive Application

Compact and Efficient

The TandemX Pump is a gerotor style pump and utilizes a single shaft drive to operate both the power steering and fuel pumps for smooth and efficient operation. The TandemX Pump is compact and is designed to fit almost any racing application with a variety of sizes and mounting configurations.



Typical Dry Sump Drive Application



**Belt Drive
TandemX Pump**

The REAL Tandem Pump - Imitated, Never Duplicated!

We've got you covered - perfect for late models, modifieds, crate & open motors, alcohol or gas applications!



**Direct Drive
TandemX Pump**

***See Pump Ordering
Instructions On Page 14**

Tandem Pumps

KSE TandemX Pump Features & Benefits

More Efficient and Improved Flow Performance

The TandemX is a gerotor style pump utilizing special tear-drop timed kidney porting and updated inlet & outlet ORB port sizing. This allows for smoother, uniform flow and improved fill capacity on the power steering and fuel pump sections.

Weight Savings

The updated TandemX design includes an integral power steering relief and a sleek, new lightened profile which has allowed for a 25% weight reduction over the previous design. This pump additionally offers a considerable weight savings over installing a separate conventional power steering pump and belt drive fuel pump...not to mention the savings!

Reduced Fluid Temps

The TandemX pump utilizes a phenolic insulator between the power steering and fuel sections in order to reduce heat transfer from one pumping element to the other.

Alcohol & Gasoline Compatible

The TandemX is fully compatible with both alcohol & gasoline. The pump can be equipped with one of two optional fuel displacements based on the engine's horsepower rating. See ordering instructions on the following page for additional details or contact KSE with questions regarding your application.

Performance & Durability

The TandemX utilizes a high-alloy heat-treated shaft, heavy-duty front ball bearings, bi-metal central journal bearings, and high-alloy billet pump body components all manufactured to the highest standards. The fuel section includes a bronze separator for the gerotor element and hard-coat anodized components for extended wear resistance.



KS Photo

Kyle Strickler - 2017 IMCA Race of Champions Winner & Longhorn Chassis Driver

Convenient Plumbing and Mounting

The TandemX utilizes easy-to-plumb inlets and outlets with standard 37° JIC/ORB fittings. The built-in fuel by-pass idle relieve valve and high-speed pill orifice cartridge reduce unnecessary plumbing and allow for "easy access" for fuel pressure adjustments. The new TandemX mounts in the same fashion as the previous tandem pump design in which the most common configurations are seen below:

- Belt Drive Pump: Front Small Block Chevy Mount
Typical for "IMCA" Modifieds
- Belt Drive Pump: Bellhousing Mount (i.e. Bert)
Typical for "UMP" Modifieds & Late Models
- Direct Drive Pump: Dry Sump Mount (Hex Drive)
Typical for Late Models

Quality & Value

As with all of KSE's racing components, quality is a must. All of KSE's pumps are built in the USA and have been 100% performance tested before delivery. The KSE TandemX pump is built to last and is fully serviceable - these pumps have proven to be an exceptional value over two separate lower quality pumps.

The Gerotor Advantage Over Gear and Internal Gear-Type Pumps

Improved Overall Efficiency & Less Input Horsepower

Due to less running friction, smaller O.D., fewer teeth, and less face area, KSE's gerotor pumps rob less horsepower...leaving more for the wheels.

Smooth, Uniform Flow

The gradual volume change of the pumping pockets result in low amplitude pulsation and uniform flow to the steering and fuel systems.

Durability

Lower surface speeds and friction result in less wear. The rugged tooth form is less prone to failure due to fluid contamination.



STEERING GEARS

TANDEM PUMPS

PULLEYS & DRIVE KITS

POWER STEERING PUMPS

WATER PUMPS & FRONT COVERS

FLUIDS & ACCESSORIES

SERVICES

TECHNICAL INFO

Belt Drive Tandem Pumps



Belt Drive TandemX Pumps

- Front Mount (CCW Rot.)
- Mount on Bert, Brinn, or Falcon Transmission
- 5/8" DIA Keyed Shaft

BELT SELECTION GUIDE & HTD BELT DRIVE KITS ARE AVAILABLE ON PAGE 16.

KSC1064-002
0.2375 CI/REV Fuel Pump
Alcohol up to 700 HP
Gasoline up to 1000 HP

KSC1064-004
0.2969 CI/REV Fuel Pump
Alcohol up to 1000 HP
Due to the high flow rate, NOT recommended for Gasoline



KSC1056
Small Block Chevy Mounting Kit



KSC1060
Crate Head Mounting Kit



KSC1059
Bert / Brinn / Falcon Transmission
Bell Housing Mounting Kit

Additional Mounting Kits Available:

KSC1058
Ford Windsor

KSC1057
Ford Cleveland

KSC1044
Bert Rear Cam Drive

Belt Drive Tandem Pump Kits

New



KSC2020-002
TandemX Belt Drive
SBC Crate Kit
Includes: Belt Drive TandemX Pump, Crate Single Belt Drive Kit (Pulleys, Mandrel, Belts), Head Mounting Kit, and Bypass Style Fuel Regulator.

New



KSC2021-002
TandemX Belt Drive
Bellhousing Kit
Includes: Belt Drive TandemX Pump, Drive Kit (Pulleys, Guides, Belts), Bert Mounting Kit, and Bypass Style Fuel Regulator.

Direct Drive Tandem Pumps



Direct Drive TandemX Pumps

- Mount on Back of Dry Sump Pump (CCW Rotation)
- Cam Drive Pump Off Back of Engine
- 3/8" Male Hex Drive
- Standard rotation (CW), front-engine cam drive also available by special order

KSC1065-002

0.2375 CI/REV Fuel Pump
Alcohol up to 700 HP
Gasoline up to 1000 HP

KSC1065-004

0.2969 CI/REV Fuel Pump
Alcohol up to 1000 HP
Due to the high flow rate, NOT recommended for Gasoline



KSC1036
D/D TandemX Pump Adapter
(Included With Pump)



KSC2008
D/D TandemX Pump Adapter
For Peterson R4 Dry Sump



KSC1019
Pump Adapter
For Square Body Pump

Tandem Rebuild Kits



KSC1077B
Bearing & Seal Kit for TandemX Pumps

KSC1076B
Bearing & Seal Kit for Tandem Pumps - S/N 5267 and up

KSC1052B
Bearing & Seal Kit for Tandem Pumps - S/N up to 5266

Fuel System Accessories



KSC2005
Billet Bypass Style
Fuel Regulator

- All Billet Design w/ ORB Ports
- Alcohol & Gas Compatible
- Adjustable Idle Jet

KSC3000
Fuel Regulator Rebuild Kit
Includes Diaphragm & Spring



KSC1075
Fuel Pill Kit
Includes: 0.120, 0.140, 0.160, 0.180, 0.200, 0.220, and 0.220

HTD Belt Drive Kits

KSE's HTD "High Torque Drive" system incorporates a high-tech radius tooth design for superior performance over other belt drives.

For belt drive Tandem pumps: KSC1064-002 & KSC1064-004

Strength

HTD systems provide more than twice the torque of conventional positive-drive systems.

Quality

All KSE drive pulleys are manufactured from 6061-T6 billet aluminum and hard-coat anodized to 72 Rc for improved durability.

Precision

All components of the KSE belt drive kits are precision CAD designed to ensure proper fit and the utmost life and functionality.

KSD1025



All HTD Belt Kits are for Small Block Chevy Only

KSD1025

HTD Single Belt Drive Kit
For V-Belt Driven Water Pump
**Works With PN# KSC1056
Tandem Pump Mounting Kit.*

KSD1026 NEW!

Crate Single Belt Drive Kit
For V-Belt Driven Water Pump
**Works With PN# KSC1060
Tandem Pump Mounting Kit.*

KSD1039

HTD Dual Belt Drive Kit
With HTD Water Pump Drive
Pulleys and Belts

HTD Belt Selection Guide

KSE offers many common HTD Belts which are suited for today's racing applications. The following list of HTD pulley combinations and belts are recommended by KSE for pump operation given the stated application.

<u>Application</u>	<u>HTD Pulley Combination</u> (Drive / Pump Pulley)	<u>Part Number / Belt Length</u>
Bert / Brinn (Rev Over 8000 RPM)	22 / 44	KSM1058-640
Bert / Brinn (Rev <u>Up To</u> 8000 RPM)	22 / 40	KSM1058-600
KSE Small Block Chevy (Front Mount)	20 / 40	KSM1058-800
KSE SBC Crate Kit (Front Mount)	22 / 40	KSM1058-840
Falcon Transmission (Winters)	24 / 48	KSM1058-640
HTD Drive Water Pump SB Chevy	25 / 35	KSM1058-600
KSE Mount Windsor	20 / 40	KSM1058-720

*To get belt length in inches, take the belt length and divide by 25.4 .
(Example: 800 / 25.4 = 31.5 inches)*

Pulleys and Belt Guides

STEERING GEARS

TANDEM PUMPS

**PULLEYS &
DRIVE KITS**

POWER STEERING
PUMPS

WATER PUMPS &
FRONT COVERS

FLUIDS &
ACCESSORIES

SERVICES

TECHNICAL INFO



KSD1019

HTD 40 Tooth Pulley

**Pulley Guides Ordered Separately*

KSD1061

Pulley Guide Set - 40 Tooth Pulley



KSD1062

HTD 44 Tooth Pulley

**Pulley Guides Ordered Separately*

KSD1063

Pulley Guide Set - 44 Tooth Pulley



KSD1069

HTD 48 Tooth Pulley

KSD1070

Pulley Guide Set - 48 Tooth Pulley



KSD1022

Crank V-Belt Pulley

Hardcoat Anodized Aluminum



KSD1017

HTD 20 Tooth Pulley

KSD1018

HTD 22 Tooth Pulley

**See Page 30 for HTD Belt Drive Kit Assembly Details. Please call if there are any questions on your specific application.*

HPD Power Steering Pumps

BLACK SERIES High Power Density Power Steering Pump

Sleek, Lightweight Profiled Finish

New contrast cut black anodized bearing section and profiled reduces overall pump weight. This is the lightest racing power steering pump made.

Improved Performance & Flow

The special design tear-drop timed porting and large -10 inlet eliminates cavitation up to 10K engine RPM.

Versatile & Durable

Carburized gun-drilled pump shaft with shielded ball bearing and 3/8" hex drive male input and female output. Will accept all popular fuel injection pumps with convenient port locations for easy plumbing.

Increased Pressure Setpoint

The HPD pump utilizes a non-sticking poppet-type relief valve which has been increased to 1600 PSI. This was made possible by the rigid construction design and zero tolerance clearances.

100% Performance Tested

Every KSE pump is flow and pressure tested to exacting & strict performance specifications.



The Best Just Got Better!

The new Black Series HPD Power Steering Pump is the lightest, most efficient high performance power steering pump made!

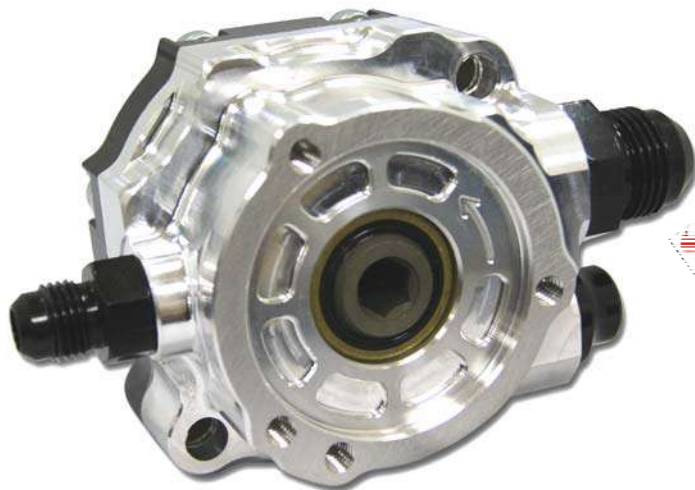

KSC1068-002

Black Series HPD Power Steering Pump

HPD Double-Ended 3/8" Hexshaft Power Steering Pump, Rear Mount Applications
(Rotates CCW When Viewed From Back Of Pump)

KSC1069B

Bearing & Seal Kit for KSC1068-002
HPD Style Power Steering Pumps



Standard Power Steering Pumps

Rotation



KSC1030-001

Double-Ended 3/8" Hexshaft Power Steering Pump,
Front Mount & Fontana Midget Applications
(Rotates Clockwise When Viewed From Back Of Pump)



Rotation



KSC1038B

Bearing & Seal Kit for
KSC1030-001 & -002

KSC1039B

S/N D5267 & up



KSC1019

Pump Adapter
For Square Body Pump

Pump Drives and Parts



KSC1043

Shielded Wide Mount Pump Adapter
Anodized Black Billet Aluminum



KSC1067

Pump Adapter for KSC1068-002
Billet Aluminum



KSD1014-100

Rear Cam Drive
3/8" hex, 1" long
Heat Treated Precision Finish

KSD1014-150

Rear Cam Drive
3/8" hex, 1.5" long
Heat Treated Precision Finish



KSD1024

Rear Cam Seal
2.100" O.D. Donovan/Stock

KSD1064

Rear Cam Seal
2.090" O.D. Rodeck

KSD1068

Rear Cam Seal
2.220" O.D. Big Block Chevy

KSD1092

Rear Cam Seal
2.510" O.D. Rodeck

Front Covers

Cool your engine with water...not fuel!

KSE's high efficiency, crank drive water pumps are designed to meet the cooling needs of today's high performance race engines. Developed utilizing state-of-the-art CAD / CFD modeling, features include:

- Timing window with four possible locations
- Eight variable inlet port locations
- High strength welded tang drive
- Mechanical ceramic seal

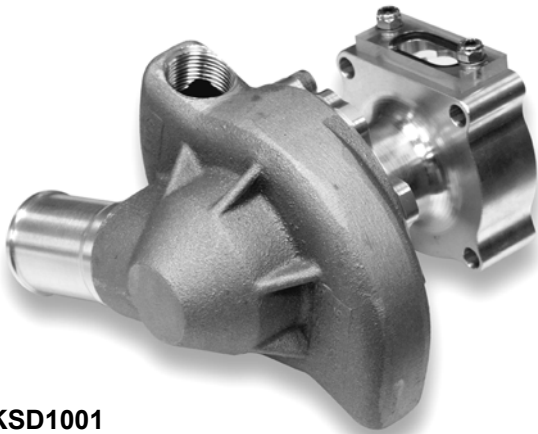
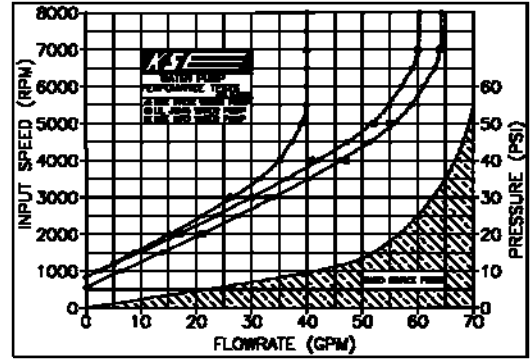

KSD1001



KSD1057

KSE Standard Pump Features

- 1-1/2" inlet fitting
- Two 3/4" NPT outlets
- Swept 6-vane billet impeller
- Designed for engines *up to* 700 HP

KSE HPD Pump Features

- 1-3/4" inlet fitting
- Two -16 ORB (1") outlets
- Internal-vane dual-scroll impeller for improved efficiency
- Designed for engines *over* 700 HP
- Higher flow and pressure capability decreases hot spot gasification and increases boundary layer scrubbing, which improves the heat conductivity to the coolant.

KSD1001

Standard Water Pump Assembly

KSD1001R

Standard Water Pump Assembly
For Crank Trigger Applications With
Elastomer Spyder Drive

KSD1044

Water Pump Assembly 1/2" Hex Drive

KSD1086

Water Pump Assembly
1/2" Hex Drive Mopar

KSD1033

Repair Kit for KSD1001

KSD1089

NEW DESIGN!
High Efficiency Billet
Impeller for KSD1001



KSD1057

HPD Water Pump Assembly

KSD1057R

HPD Water Pump Assembly
For Crank Trigger Applications With
Elastomer Spyder Drive

KSD1058

HPD Water Pump Assembly
1/2" Hex Drive



STEERING GEARS

TANDEM PUMPS

PULLEYS &
DRIVE KITS

POWER STEERING
PUMPS

WATER PUMPS &
FRONT COVERS

FLUIDS &
ACCESSORIES

SERVICES

TECHNICAL INFO

Water Pump Drive Components



KSD1011
Crank Drive (Water Pump)
Steel



KSD1011L
Crank Drive (Water Pump)
Aluminum (Hardcoat Anodized)



KSD1093
Crank Drive Big Block Chevy
Steel



KSD2001
Billet Aluminum Timing Cover
• Billet Aluminum Plate
• ORB Anodized Plug
• Simplifies Timing



KSD1012
Timing Window Cover
Aluminum

KSD1013
Timing Window Cover
Lexan (Standard)

KSM1020-120
Timing Window O-Ring

Elastomer Water Pump Drive For "Dry" Applications



KSD1040
Elastomer Spyder Drive



KSD2002
Threaded SS Spyder Coupler
For RCD Style Crank Trigger

KSD2003
Threaded SS Spyder Coupler
For MSD Style Crank Trigger

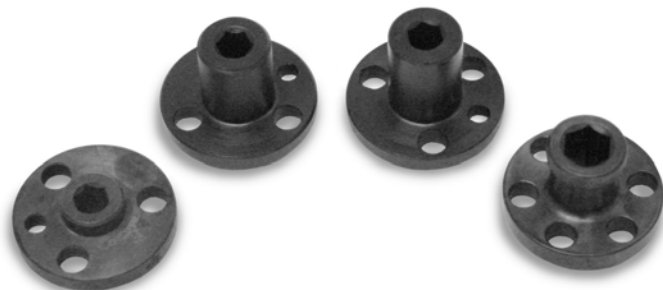

KSD1010-051
Front Cam Drive
3/8" hex, 0.515" long

KSD1010-125
Front Cam Drive
3/8" hex, 1.250" long

KSD1010-140
Front Cam Drive
3/8" hex, 1.400" long

KSD1023
Front Cam Drive
1/2" hex, Dry Sump

STEERING GEARS

TANDEM PUMPS

PULLEYS &
DRIVE KITS

POWER STEERING
PUMPS

WATER PUMPS &
FRONT COVERS

FLUIDS &
ACCESSORIES

SERVICES

TECHNICAL INFO

Front Covers

With over twenty years of race-proven performance and durability, KSE front covers and water pumps are trusted by the nation's premier engine builders.



- Compatible with all gear and chain cam drive systems
- Bolt patterns accept all popular dry sump pumps
- CNC machined from high quality aluminum castings and solid billet aluminum

All Front Cover Components for Small Block Chevy Based Race Applications Only



KSD1002
Front Cover, Aluminum
Standard Cam Position

KSD1003
Front Cover, Billet Aluminum
Standard Cam Position

KSD1003H
NEW DESIGN!
Front Cover, Billet Aluminum
Raised Cam Position



KSM1065
Pan Lip Seal Kit
Pete Jackson and Chain Drive
Cams



KSM1011-200
Water Pump Stud (4 required)



KSD1009
Hose Block Mounts



KSD1027
Water Pump Block-Off
Long



KSD1028
Water Pump Block-Off
Short

STEERING GEARS

TANDEM PUMPS

PULLEYS &
DRIVE KITS

POWER STEERING
PUMPS

WATER PUMPS &
FRONT COVERS

FLUIDS &
ACCESSORIES

SERVICES

TECHNICAL INFO

Water Pump & Front Cover Kits



How to Order:

Create the part number of the kit you need by selecting the desired options in the boxes below and insert their code number into the part number.

Example:

KSD10-21101 is a timing cover kit with an HPD water pump, billet cover, two short hose block-offs, a Lexan timing window, and an aluminum crank drive

WAIVER WARRANTY (EXPRESSED OR IMPLIED) NO GUARANTEE

This product and each part thereof, is sold "AS IS" and with all faults. KSE Racing Products, Inc will not be liable for any loss, damage, or injury arising from the use of this product. RACING IS A DANGEROUS ACTIVITY. The user shall determine the suitability and safety of the product for its intended use, and the user assumes all responsibility and risk in connection therewith.

KSD10-

Water Pump Code	Cover Material Code	Hose Block Code	Timing Window Code	Crank Drive Code
1 = Standard Water Pump 2 = HPD Water Pump	0 = Aluminum F/C 1 = Billet Aluminum Standard Cam 2 = Billet Aluminum Raised Cam No Pan Lip for Most Gear Drives	0 = Hose Mount Blocks 1 = Two Short Block-Offs 2 = One Long and One Short Block-Off	0 = Lexan Timing Window 1 = Aluminum Timing Window Cover Plate	0 = Steel Crank Drive 1 = Aluminum Crank Drive

Filter Reservoirs



*More
Than
Just
An
Oil
Can!*



**Now Includes
Firewall Mounting Kit!**



Dual Screen Filter Design

The new dual filter reservoir utilizes two removable screen filters to provide superior protection against power steering system contamination and debris. The stainless steel filter elements can be accessed by removal of inlet /outlet fittings allowing for cleaning.

Sleek Billet Design & Construction

The dual filter reservoir is manufactured from billet aluminum. Standard ORB / 37° JIC fittings located on the bottom of the reservoir help simplify plumbing to the pump and from the steering box, steering system performance.

Smoother Operation & Cooler Fluid Temperatures

The new reservoir is designed for adequate fluid dwell time for cooling and de-aeration under all racing conditions which helps prevent pump starvation and cavitation under hard cornering conditions. The unique cooling fin design also increases surface area for improved convective cooling performance.

Vented Reservoir Fill Cap

A vented reservoir fill cap is an absolute must on a high quality power steering fluid reservoir. This feature helps improve pump seal durability and overall power steering system performance.

KSF2000-010M

Dual Filter Power Steering Fluid Reservoir - #10 Outlet / #6 Inlet
Includes Firewall Mounting Kit

KSF2015-125

Reservoir Tube Mounting Kit
For 1.25" Diameter Tubing

KSF2015-150

Reservoir Tube Mounting Kit
For 1.50" Diameter Tubing

KSF1001

Replacement Filter Element
Suction Side (To Pump)

Elixer Power Steering Fluid

The Elixer Racing Power Steering Fluid

With the frequency and pressure of racing power assist being twice that of stock power systems, it's obvious that stock power steering fluid is not adequate. Would you use 10W30 motor oil in a racing engine? Of course not! That is why KSE has developed a power steering fluid designed to handle the stresses of racing power steering.

The Elixer has a higher viscosity index, anti-foaming, anti-wear, and anti-oxidation capabilities to handle the racing power steering stresses. The Elixer will minimize power assist fade, low-corner-speed assist loss, and decrease heat generation. We also have made the color a "cool" blue to help in identifying oil leak origins.

The Elixer completes the total racing power steering system. When it comes to steering, go with a name you can trust...KSE!



KSM1086

Elixer, 1 Quart

KSM1091

Elixer, 1 Gallon

KSM1086C

Elixer, Case of 6 Quarts

KSM1091C

Elixer, Case of 4 Gallons

*Special quantity
discounts apply -
See current price
sheet for details*

Service

Keep your equipment in top condition!

Let the experts at KSE service your equipment with the same care they use to assemble every new gear and pump. Our rigorous process involves a complete tear-down and test of your unit to ensure "like new" performance.

Whether it's a "battle weary" gear or simply a "once over" before next season, trust your equipment to KSE's experts.

To request service, please include the following:

- Your Name
- Your Address
- Your Daytime Phone Number
- Your Email Address



Valve Testing



STEERING GEAR SERVICE*

Includes:

- Labor
- New Seal Kit
- Magnaflux Zyglo Inspection
- Servo-Valve & Backlash Adjustment
- Pressure & Load Test

**Also serviced: Lee, GME / Nields, Profile, and NBC gears

POWER STEERING PUMP SERVICE*

Includes:

- Labor
- Blueprint to Factory Specifications
- New Seal kit
- Flow Test
- Pressure Test

TANDEM PUMP SERVICE*

Includes:

- Labor
- Blueprint to Factory Specifications
- New Seal kit
- Flow Test
- Pressure Test

WATER PUMP SERVICE*

Includes:

- Labor
- Blueprint to Factory Specifications
- New Seal Kit
- Shaft Bearing Assembly

* If any parts or service over and above the above services are required, the customer will be notified with a cost estimate for their approval.

STEERING GEARS

TANDEM PUMPS

PULLEYS &
DRIVE KITS

POWER STEERING
PUMPS

WATER PUMPS &
FRONT COVERS

FLUIDS &
ACCESSORIES

SERVICES

TECHNICAL INFO

Technical Information

KSGEN2-XXXXX

Gen2 Steering Gear Assembly (Left Side)

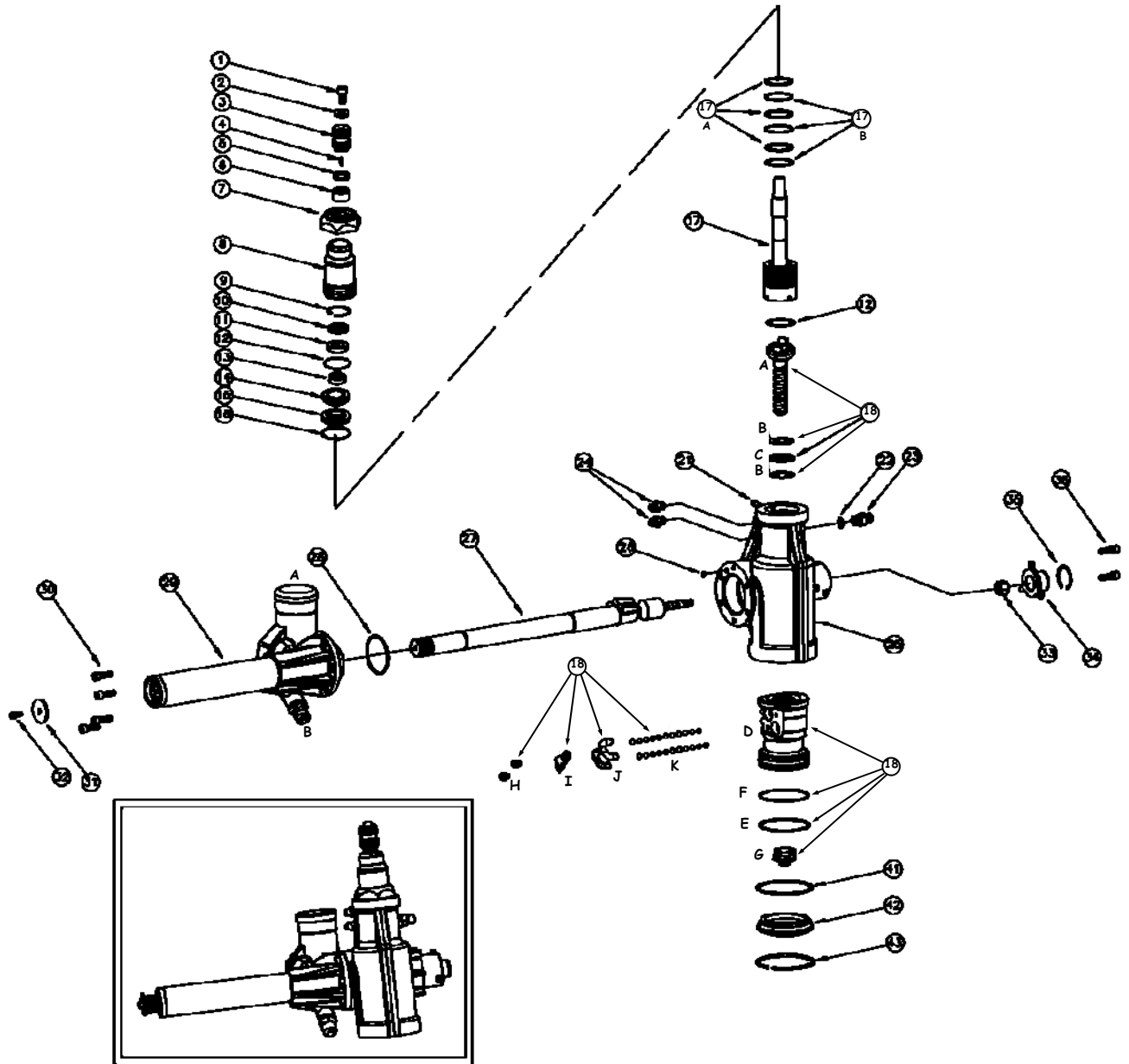

Technical Information

ITEM	DESCRIPTION	PART#
1.	3/8-24 UNF SHCS	KSM 1057-075
2.	HARDENED FLAT WASHER	KSM 1097-375
3.	QUICK RELEASE ADAPTER (SPLINED)	KSG 1025
4.	PIN DRIVE HUB	KSM 1056
5.	INPUT LIP SEAL	KSM 1063
6.	NEEDLE BEARING (7/8")	KSM 1062
7.	INPUT JAM NUT	KSG 1059
8.	INPUT TUBE / COLLAR (10" OR 11")*	KSG 1055-XXX
9.	INT. SNAP RING – INPUT TUBE	KSM 1026-137
10.	INPUT LIP SEAL – THIN	KSM 1034
11.	INPUT LIP SEAL – THICK	KSM 1035
12.	BALL SCREW / BC O-RING B/70 (2 REQ)	KSM 1020-030
13.	BEARING COLLAR	KSG 1056
14.	NEEDLE BEARING – BC	KSM 1042
15.	INPUT THRUST BEARING ASSY.	KSG 1035
16.	INPUT NUT O-RING B/70	KSM 1020-133
17.	VALVE ASSEMBLY	KSG 005X-2XX*
	A VALVE TEFLON RINGS (3 REQ)	KSG 1042-031
	B VALVE O-RING B/70 (3 REQ)	KSM 1020-031
18.	RACK ASSEMBLY	KSG 0029
	A BALL SCREW	(N/A)
	B THRUST WASHERS	KSG 1088
	C THRUST BEARING	KSG 1087
	D RACK PISTON	(N/A)
	E O-RING	KSM 1020-149
	F PISTON RING	KSG 1041-149
	G RACK PLUG	KSG 1063
	H RETAINER STRAP SCREWS (2 REQ)	(N/A)
	I RETAINER STRAP	(N/A)
	J BALL CHANNELS	(N/A)
	K BALLS	(N/A)
21.	10-32 UNF SHCS – INPUT NUT LOCK	KSM 1002-625
22.	O-RING - TUBE FITTING (2 REQ)	KSM 1021-906
23.	#6 ORB TO #6 JIC STRAIGHT BLUE	KSM 1016B
24a.	#3 O-RING #3 37° FLARE	KSM 6002
24b.	OPTIONAL #3 O-RING PLUG	KSM 6001
25.	CENTER SECTION	KSG 1074
26.	RETURN PORT O-RING	KSM 1021-110
27.	CROSS SHAFT ASSEMBLY	KSG 0022-XXG2**
28.	O-RING SIDE HUB B/70	KSM 1020-143
29.	LIVE HUB RESERVOIR ASSEMBLY	KSG 1055-0XX**
	A RESERVOIR CAP AND DIP STICK	KSM 1052DS
	B #10 O-RING TO #10 AN FITTING	KSM 1073
30.	5/16-18 UNC SHCS (4 REQ)	KSM 1005-087
31.	DUST COVER/PITMAN ARM WASHER	KSM 1095
32.	1/4-28 UNF SHCS	KSM 1004-050
33.	UNF NEO LOCK NUT	KSM 1048-437
34.	BACKLASH BOLT COVER	KSG 1077
35.	COVER RETAINING RING	KSM 1026-175
36.	SHCS (2 REQ)	KSM 1005-250
41.	O-RING BOTTOM PLATE B/70	KSM 1020-236
42.	BOTTOM RETAINING PLATE	KSG 0028
43.	WIRE RETAINER RING – BOT. PLATE	KSM 1025
48.	1/16-27 NPT (2 REQ)	KSM 1112-062

SEAL KIT (INCLUDES ITEMS 12, 14, 18F, 19, 20, 26, 28, 33, 41, 43)....KSG-0035

* ORDER ACCORDING TO VALVE INPUT SHAFT LENGTH (005X) 0054=10", 0055=11", AND TORSION BAR SIZE (-2XX). SEE GEAR ORDERING INFORMATION. LENGTHS MEASURED FROM GEAR CENTERLINE.

** ORDER ACCORDING TO LENGTH (XX): 14, 16, OR 18 INCH LENGTHS AS MEASURED FROM GEAR CENTERLINE TO END OF SPLINES.

***BLACK SERIES GEN2 GEARS - CONTACT US FOR PARTS / ORDERING DETAILS.

STEERING GEARS

TANDEM PUMPS

FUEL PUMPS

POWER STEERING PUMPS

ACCESSORIES & FLUIDS

WATER PUMPS FRONT COVERS

SERVICE

TECHNICAL INFO

Technical Information

KSG10-XXXXX Standard Steering Gear Assembly (Left Side)
(Discontinued)

KSG11-XXXXX Standard Steering Gear Assembly (Right Side)
(Differs from illustration; call for right-side gear parts)

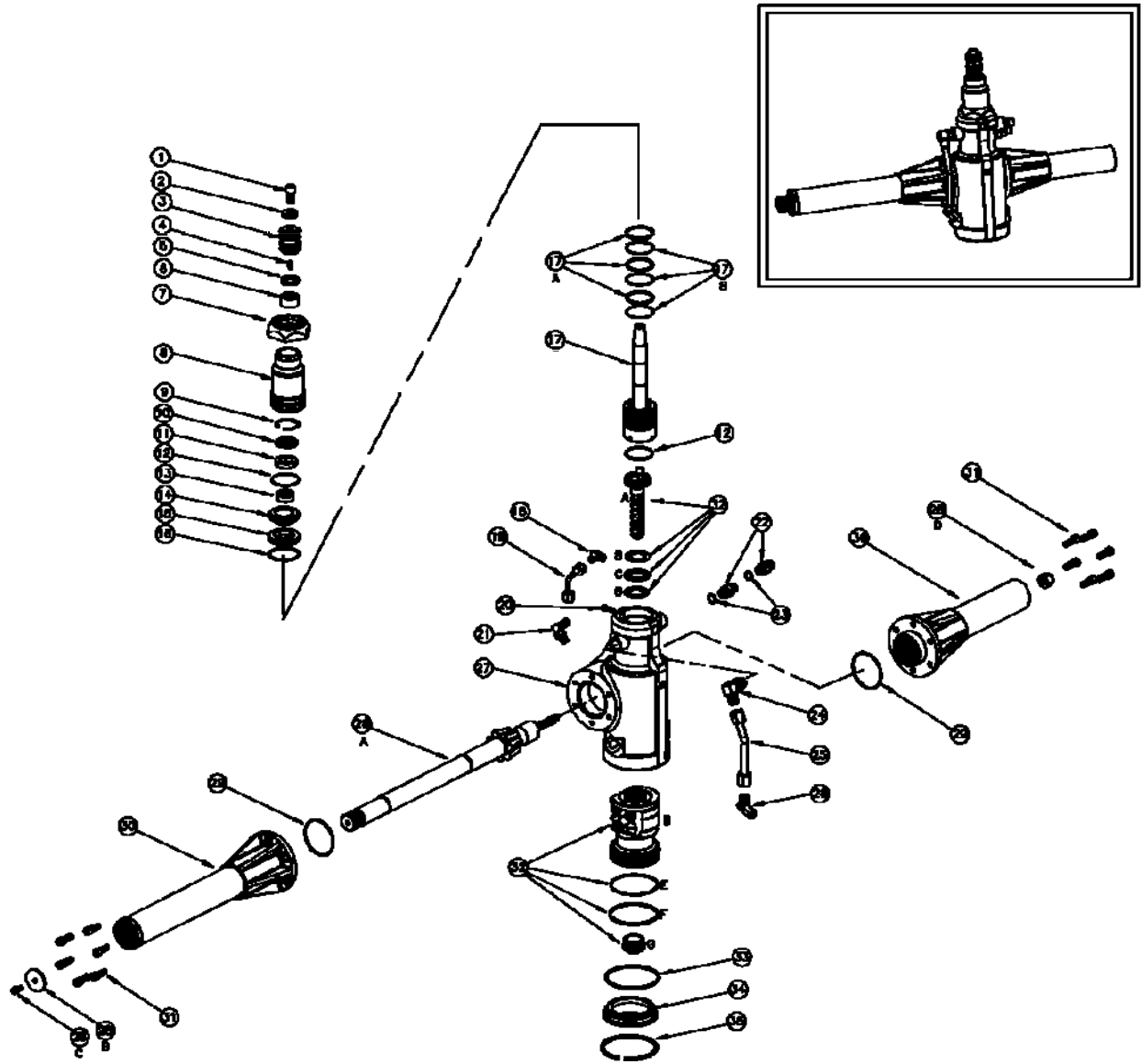

Technical Information

ITEM	DESCRIPTION	PART#
1.	3/8-24 UNF SHCS	KSM 1057-075
2.	HARDENED FLAT WASHER	KSM 1097-375
3.	QUICK RELEASE ADAPTER (SPLINED)	KSG 1025
4.	PIN DRIVE HUB	KSM 1056
5.	INPUT LIP SEAL	KSM 1063
6.	NEEDLE BEARING (7/8")	KSM 1062
7.	INPUT JAM NUT	KSG 1059
8.	INPUT TUBE / COLLAR (10" OR 11")*	KSG 1055-XXX
9.	INT. SNAP RING – INPUT TUBE	KSM 1026-137
10.	INPUT LIP SEAL – THIN	KSM 1034
11.	INPUT LIP SEAL – THICK	KSM 1035
12.	BALL SCREW / BC O-RING B/70 (2 REQ)	KSM 1020-030
13.	NEEDLE BEARING – BC	KSG 1056
14.	BEARING COLLAR	KSM 1042
15.	INPUT THRUST BEARING ASSY.	KSG 1035
16.	INPUT NUT O-RING B/70	KSM 1020-133
17.	VALVE ASSEMBLY	KSG 005X-2XX*
	A VALVE TEFLON RINGS (3 REQ)	KSG 1042-031
	B VALVE O-RING B/70 (3 REQ)	KSM 1020-031
18.	#4 NPT TO #4 JIC - 45° FITTING	KSM 1015
19.	1/4" TUBE ASSEMBLY (INCLUDES TUBE, NUT, SLEEVE)	KSG 0016
20.	10-32 UNF SHCS – INPUT NUT LOCK	KSM 1002-075
21.	90° ORIFICE FITTING	KSG 0018
22.	#6 ORB TO #6 JIC STR FITTING (2 REQ)	KSM 1016B
23.	O-RING - TUBE FITTING (2 REQ)	KSM 1021-906
24.	#6 ORB TO #6 JIC - 90° FITTING	KSM 1013
25.	3/8" TUBE ASSEMBLY (INCLUDES TUBE, NUT, SLEEVE)	KSG 0017
26.	#6 ORB TO #6 JIC - 45° FITTING	KSM 1014
27.	CENTER SECTION	KSG 0001L
28.	CROSS SHAFT ASSEMBLY (A,B,C,D)	KSG 0022-XX**
29.	O-RING SIDE HUB B/70 (2 REQ)	KSM 1020-141
30.	LIVE HUB ASSEMBLY	KSG 0004-XX**
31.	5/16-18 UNC SHCS (12 REQ)	KSM 1005-087
32.	STANDARD RACK ASSY (A,B,C,D,E,F,G)	KSG 0023
	A BALL SCREW	(N/A)
	B THRUST WASHER	KSG 1086
	C THRUST BEARING	KSG 1085
	D RACK PISTON AND BALLS	(N/A)
	E O-RING	KSM 1020-149
	F PISTON RING	KSG 1041-149
	G RACK PLUG	KSG 1063
33.	O-RING BOTTOM PLATE B/70	KSM 1020-236
34.	BOTTOM RETAINING PLATE	KSG 0028
35.	WIRE RETAINER RING – BOT. PLATE	KSM 1025
36.	DEAD SIDE HUB ASSEMBLY	KSG 0008-XXX***

SEAL KIT (INCLUDES ITEMS 12, 16, 17A, 17B, 29, 32E, 32F, 33, 35) .. KSG-0032

* ORDER ACCORDING TO VALVE INPUT SHAFT LENGTH (005X) 0054=10", 0055=11", AND TORSION BAR SIZE (-2XX). SEE GEAR ORDERING INFORMATION. LENGTHS MEASURED FROM GEAR CENTERLINE.

** ORDER ACCORDING TO LENGTH (XX): 14, 16, OR 18 INCH LENGTHS AS MEASURED FROM GEAR CENTERLINE TO END OF SPLINES.

*** ORDER ACCORDING TO DEAD SIDE LENGTH (XXX) 900=9", 105=10.5"

STEERING GEARS

TANDEM PUMPS

FUEL PUMPS

POWER STEERING PUMPS

ACCESSORIES & FLUIDS

WATER PUMPS FRONT COVERS

SERVICE

TECHNICAL INFO

Technical Information

KSD1025 HTD Single Belt Drive Kit

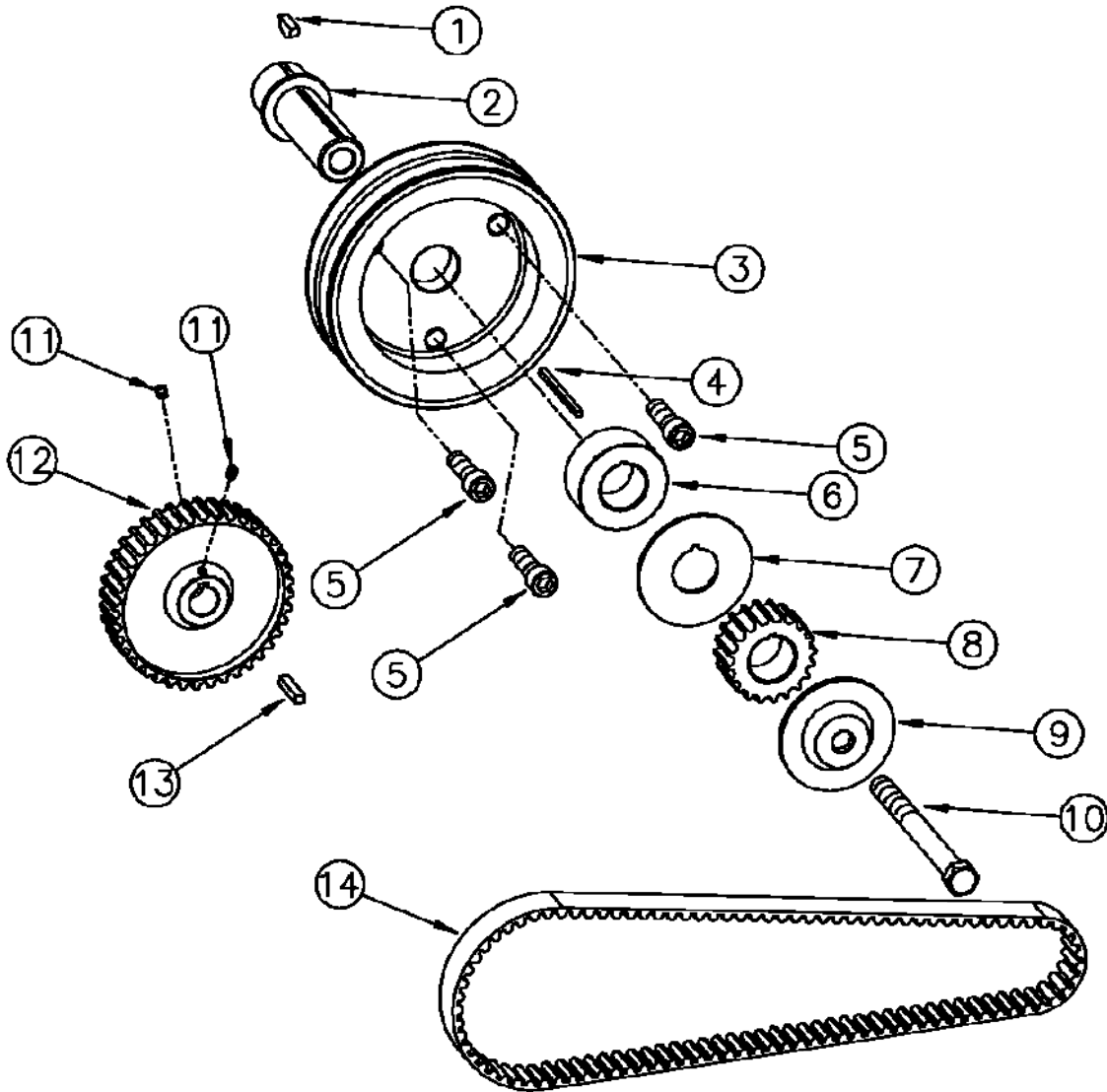

ITEM	DESCRIPTION	PART#
1.	WOODRUFF KEY	KSM 1030-009
2.	MANDREL	KSD 1015-270
3.	W/P PULLEY	KSD 1022
4.	1/8 STRAIGHT KEY	KSM 1028-212
5.	3/8 X 24 SHCS (3 REQ)	KSM 1057-125
6.	DRIVE PULLEY SPACER	KSD 1016
7.	DRIVE PULLEY SEPERATOR	KSD 1020
8.	20 TOOTH PULLEY	KSD 1017
9.	MANDREL DRIVE CAP	KSD 1021
10.	7/16 X 20 X 4 3/4" HEX BOLT	KSM 1012-475
11.	10-24 SHCS (2 REQ)	KSM 1008-025
12.	40 TOOTH PULLEY	KSD 1019
13.	3/16 STRAIGHT KEY	KSM 1029-100
14.	H.T.D. BELT (800-8M-20)	KSM 1058-800

STEERING GEARS

TANDEM PUMPS

FUEL PUMPS

POWER STEERING PUMPS

ACCESSORIES & FLUIDS

WATER PUMPS FRONT COVERS

SERVICE

TECHNICAL INFO

Technical Information

KSD1039 HTD Dual Belt Drive Kit

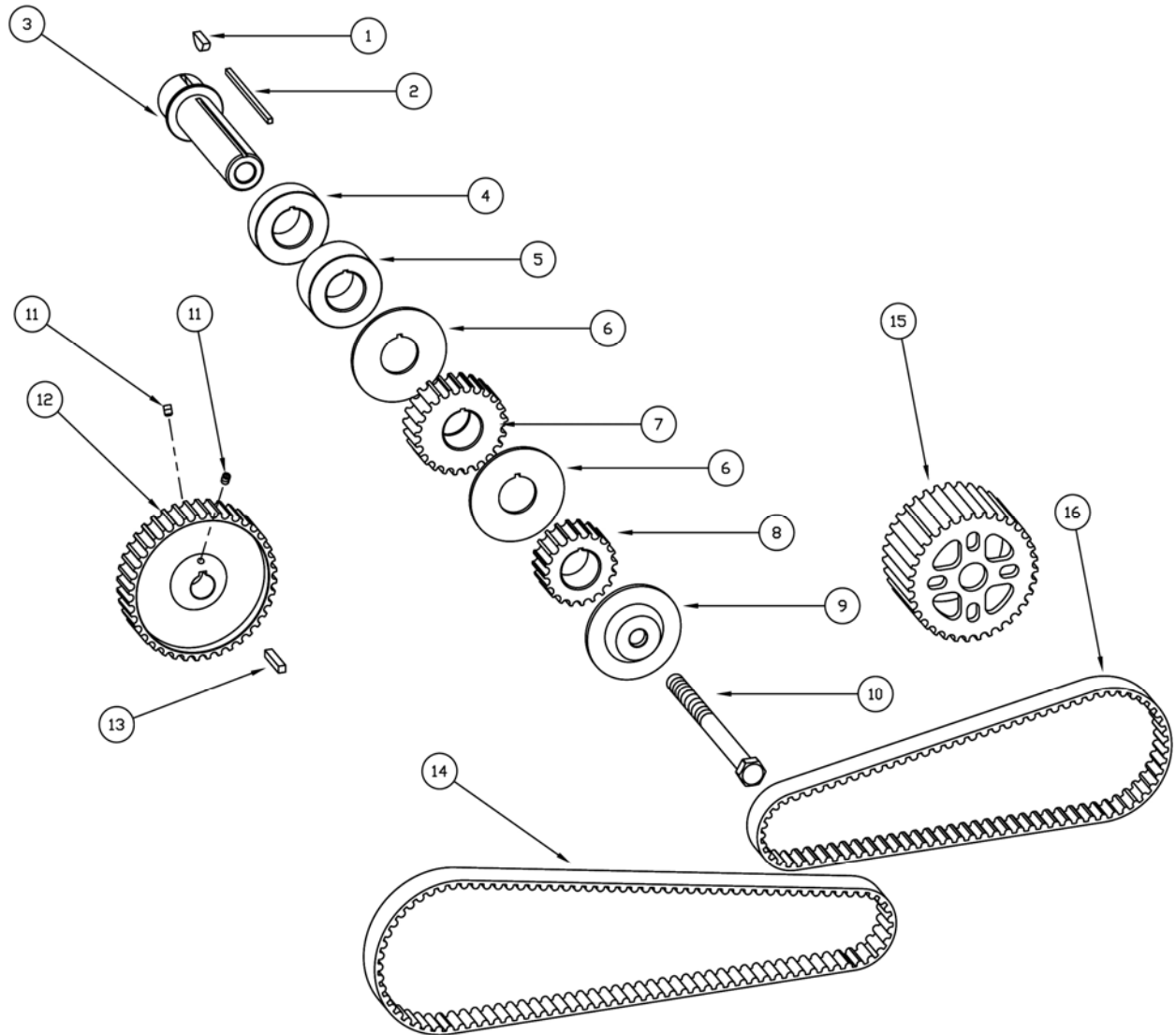

ITEM	DESCRIPTION.....	PART#
1.	WOODRUFF KEY.....	KSM 1030-009
2.	1/8 STRAIGHT KEY.....	KSM 1028-312
3.	MANDREL.....	KSD 1015-368
4.	DRIVE PULLEY SPACER - SHORT.....	KSD 1016S
5.	DRIVE PULLEY SPACER.....	KSD 1016
6.	DRIVE PULLEY SEPERATOR (2 REQ).....	KSD 1020
7.	25 TOOTH PULLEY.....	KSD 1037
8.	20 TOOTH PULLEY.....	KSD 1017
9.	MANDREL DRIVE CAP.....	KSD 1021
10.	7/16 X 20 X 5 1/2" HEX BOLT.....	KSM 1012-550
11.	10-24 SHCS (2 REQ).....	KSM 1008-025
12.	40 TOOTH PULLEY.....	KSD 1019
13.	3/16 STRAIGHT KEY.....	KSM 1029-100
14.	HTD BELT (800-8M-20).....	KSM 1058-800
15.	35 TOOTH WATER PUMP PULLEY.....	KSD 1036
16.	HTD BELT (600-8M-20).....	KSM 1058-600

STEERING GEARS

TANDEM PUMPS

FUEL PUMPS

POWER STEERING PUMPS

ACCESSORIES & FLUIDS

WATER PUMPS FRONT COVERS

SERVICE

TECHNICAL INFO

Technical Information

KSC1030-001 Hex Drive Standard Rotation Power Steering Pump

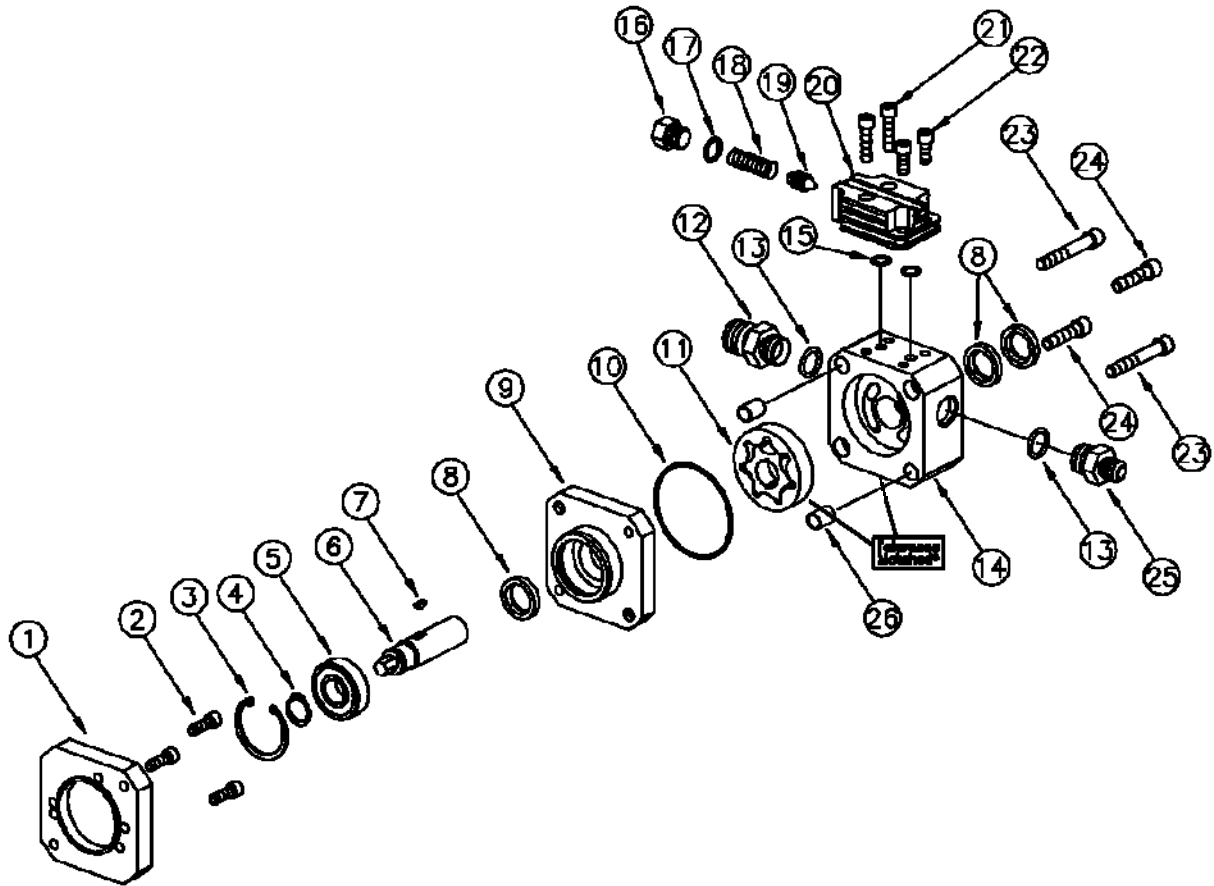

ITEM	DESCRIPTION	PART #
1.	PUMP MOUNTING ADAPTER	KSC1019
2.	1/4 20 X 3/4" SHCS MGF. ADPT BOLT (2 REQ)	KSM1003-075
3.	SHAFT & BEARING RETAINING RING	KSM1026-156
4.	DRIVE SHAFT BEARING RETAINING RING	KSM1027-066
5.	DRIVE SHAFT BEARING	KSM1039
6.	3/8" HEX DRIVE SHAFT	KSC1027
7.	WOODRUFF KEY DRIVE	KSM1030-213
8.	SHAFT SEAL (3 REQ)	KSM1037
9.	BEARING SECTION	KSC1028
10.	BEARING SECTION O-RING	KSM1020-038
11.*	GEROTOR PUMPING ASSEMBLY	KSM1023-500
12.	INLET FITTING #8 ORB #10 JIC	KSM1059
13.	#8 O-RING (2 REQ)	KSM1021-908
14.*	DOUBLE ENDED PUMP BODY	KSC1017
15.	MOUNTED VALVE MTG O-RING	KSM1020-013
16.	RELIEF VALVE CAP #6 ORB	KSM1019
17.	#6 O-RING	KSM1021-906
18.	RELIEF VALVE SPRING	KSC1023
19.	RELIEF VALVE POPPET	KSC1031
20.	MOUNTED VALVE BODY	KSC1025
21.	1/4 28 X 1" SHCS MOUNTED VALVE BOLT (2 REQ)	KSM1004-100
22.	1/4 28 X 5/8" SHCS MOUNTED BOLT (2 REQ)	KSM1004-062
23.	5/16 18 X 2" SHCS MOUNTING BOLT (2 REQ)	KSM1005-200
24.	5/16 18 X 1 1/4" SHCS ASSY BOLT (2 REQ)	KSM1005-125
25.	PRESSURE FITTING#8 ORB #6 JIC	KSM1017
26.	HOLLOW DOWEL (2 REQ)	KSC1033-060

*These items are tolerance matched and are recommended to be purchased as a set.

Pump Rebuild / Seal Kit for SN's Up To 5266 (Includes #5, #7, #8, #10, #15).....KSC1038B
 Pump Rebuild / Seal Kit for SN's 5267 & Up (Includes #5, #7, #8, #10, #15).....KSC1039B

STEERING GEARS

TANDEM PUMPS

FUEL PUMPS

POWER STEERING PUMPS

ACCESSORIES & FLUIDS

WATER PUMPS FRONT COVERS

SERVICE

TECHNICAL INFO

Technical Information

KSC1068-002 HPD Power Steering Pump

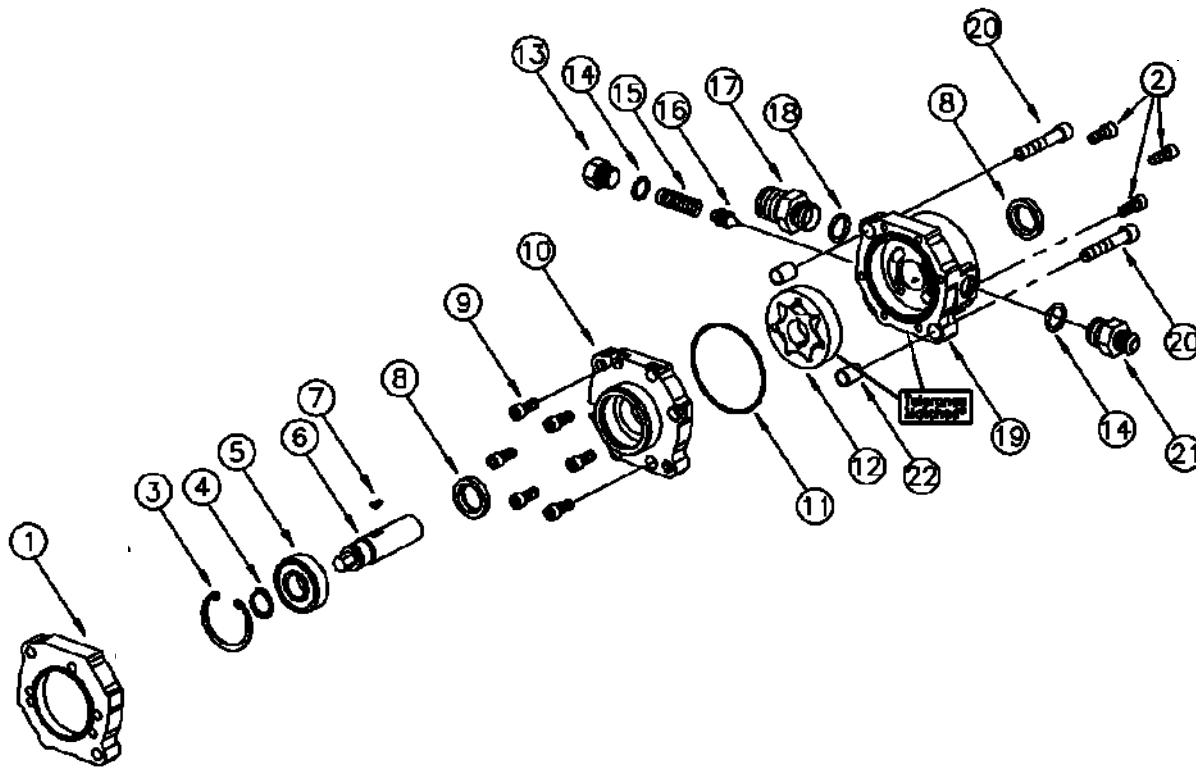

ITEM	DESCRIPTION.....	PART#
1.	PUMP MOUNTING ADAPTOR.....	KSC 1067
2.	¼ 20 X 5/8 SHCS MOUNTING BOLTS (3 REQ).....	KSM 1003-062
3.	SHAFT & BEARING RETAINING RING.....	KSM 1026-156
4.	DRIVE SHAFT BEARING RETAINING RING.....	KSM 1027-066
5.	DRIVE SHAFT BALL BEARING.....	KSM 1039
6.	3/8" HEX DRIVE SHAFT.....	KSC 1027
7.	PUMP WOODRUFF KEY.....	KSM 1030-213
8.	SHAFT SEAL (2 REQ).....	KSM 1110
9.	¼ 20 X 5/8 SHCS (6 REQ).....	KSM 1003-062
10.	H.P.D. BEARING SECTION.....	KSC 1064
11.	BEARING SECTION O'RING.....	KSM 1020-037
12.*	GEROTOR PUMPING ASSEMBLY.....	KSM 1023-500
13.	RELIEF VALVE CAP.....	KSC 1066
14.	#6 O'RING (2 REQ).....	KSM 1021-908
15.	RELIEF VALVE SPRING.....	KSC 1023
16.	RELIEF VALVE POPPET.....	KSC 1031
17.	INLET FITTING #10 ORB - #10 JIC.....	KSM 1073
18.	#10 O'RING.....	KSM 1021-910
19.*	H.P.D. DOUBLE ENDED PUMP BODY.....	KSC 1065
20.	5/16 18 X 1 ¼" SHCS MTG BOLT (2 REQ).....	KSM 1005-200
21.	PRESSURE FITTING #6 ORB - #6 JIC.....	KSM 1016
22.	HOLLOW DOWELL (2 REQ).....	KSC 1033-060

*These items are tolerance matched and are recommended to be purchased as a set.

Pump Rebuild / Seal Kit (Includes #5, #7, #8, #11).....KSC1069B

"Black Series" HPD Power Steering Pump - Contact Us For Parts Ordering Details

STEERING GEARS

TANDEM PUMPS

FUEL PUMPS

POWER STEERING PUMPS

ACCESSORIES & FLUIDS

WATER PUMPS FRONT COVERS

SERVICE

TECHNICAL INFO

Technical Information

KSC1061-XXX Belt Drive Tandem Pump

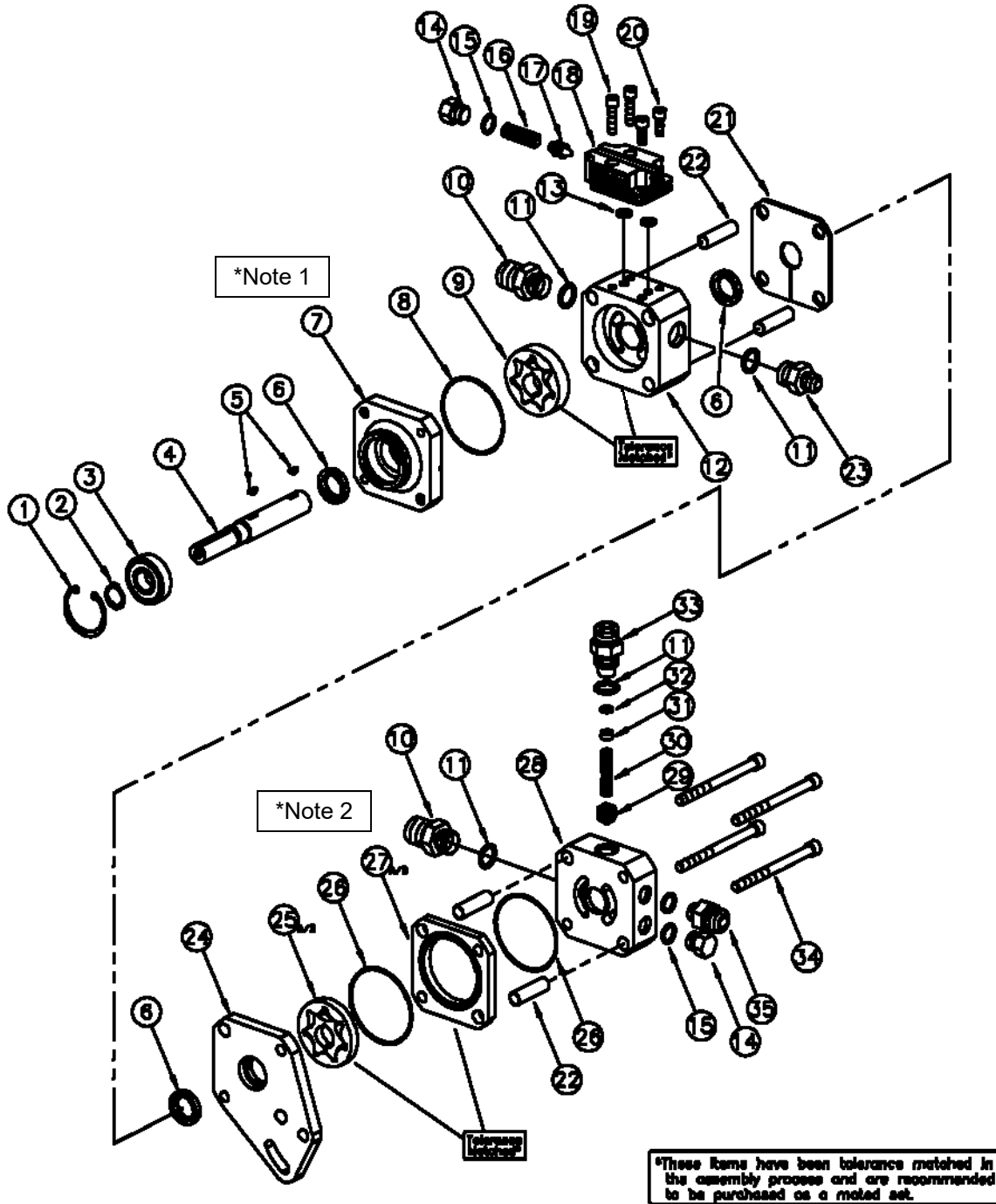

- *It is critical to assemble the components in the correct orientation as shown in order to avoid seal damage.
- *Note 1: Pump SN# should be oriented towards top of pump with "notch" positioned towards pressure fitting.
- *Note 2: Fuel section eccentric should be located towards top of pump as shown (Item #27).

Technical Information

ITEM	DESCRIPTION.....	PART #
1.	SHAFT & BEARING RETAINING RING.....	KSM1026-156
2.	DRIVE SHAFT BEARING RETAINING RING.....	KSM1027-066
3.	DRIVE SHAFT BALL BEARING.....	KSM1039
4.	BELT DRIVE SHAFT.....	KSC1007
5.	PUMP WOODRUFF KEY (2 REQ).....	KSM1030-213
6.	SHAFT SEALS (3 REQ).....	KSM1037 (S/N UP TO 5266) KSM1110 (S/N 5267 AND LATER)
7.	P/S BEARING SECTION.....	KSC1016
8.	P/S BEARING SECTION O-RING.....	KSM1020-038
9.*	P/S GEROTER PUMPING ASSEMBLY.....	KSM1023-500
10.	#8 ORB #10 JIC.....	KSM1059
11.	#8 O-RING (3 REQ).....	KSM1021-908
12.*	POWER STEERING PUMP BODY.....	KSC1010
13.	MOUNTED VALVE MTG O-RING (2 REQ).....	KSM1020-013
14.	RELIEF VALVE CAP (6 ORB).....	KSM1019
15.	#6 O-RING (3 REQ).....	KSM1021-906
16.	RELIEF VALVE SPRING.....	KSC1023
17.	RELIEF VALVE POPPET.....	KSC1031
18.	RELIEF VALVE BODY.....	KSC1025
19.	RELIEF VALVE BODY BOLT (2 REQ).....	KSM1004-100
20.	1/4 28 X 1 SHCS RELIEF VALVE BODY BOLT (2 REQ).....	KSM1004-062
21.	1/4 28 X 5/8 SHCS INSULATOR PLATE.....	KSC1014
22.	HOLLOW DOWEL (4 REQ).....	KSC1033-149
23.	P/S PRESSURE OUT FITTING #8 ORB #6 JIC.....	KSM1017
24.	MOUNTING SEPARATOR PLATE.....	KSC1020
25.*	FUEL PUMP GEROTER SET FOR PUMPS KSC1062-002 (1/4").....	KSM1023-250
	KSC1062-004 (5/16").....	KSM1023-312
26.	FUEL SECTION SPACER O-RING (2 REQ).....	KSM1020-037
27.*	FUEL SECTION SPACER (BRONZE) FOR PUMP KSC1062-002 (1/4").....	KSC1041-250
	KSC1062-004 (5/16").....	KSC1041-312
28.	FUEL PUMP MANIFOLD (INCLUDES SEAT).....	KSC1046
29.	FUEL BYPASS VALVE POPPET.....	KSC1029
30.	FUEL BYPASS VALVE SPRING.....	KSC1015
31.	FUEL PILL .120 ORFICE.....	KSC1026-120
	.140 ORFICE.....	KSC1026-140
	.160 ORFICE.....	KSC1026-160
	.180 ORFICE.....	KSC1026-180
	.200 ORFICE.....	KSC1026-200
	.220 ORFICE.....	KSC1026-220
	.240 ORFICE.....	KSC1026-240
	BLANK-NO ORFICE.....	KSC1026-000
32.	FUEL BYPASS VALVE FITTING PILL O-RING.....	KSM1020-011
33.	FUEL BYPASS VALVE FITTING.....	KSC1051
34.	5/16 X 18 X 3 3/4 SHCS ASSY BOLT (4 REQ).....	KSM1005-375
35a.	FUEL PRESSURE OUT FITTING #6 ORB #8 JIC.....	KSM1060
35b.	OPTIONAL #6 ORB #6 JIC.....	KSM1016

*These items are tolerance matched and are recommended to be purchased as a set.

Tandem Pump Rebuild / Seal Kit for SN's Up To 5266 (Includes #3, #5, #6, #8, #13, #26).....KSC1052B

Tandem Pump Rebuild / Seal Kit for SN's 5267 & Up (Includes #3, #5, #6, #8, #13, #26).....KSC1076B

STEERING GEARS

TANDEM PUMPS

FUEL PUMPS

POWER STEERING PUMPS

ACCESSORIES & FLUIDS

WATER PUMPS FRONT COVERS

SERVICE

TECHNICAL INFO

Technical Information

KSC1062-XXX Direct Drive Tandem Pump

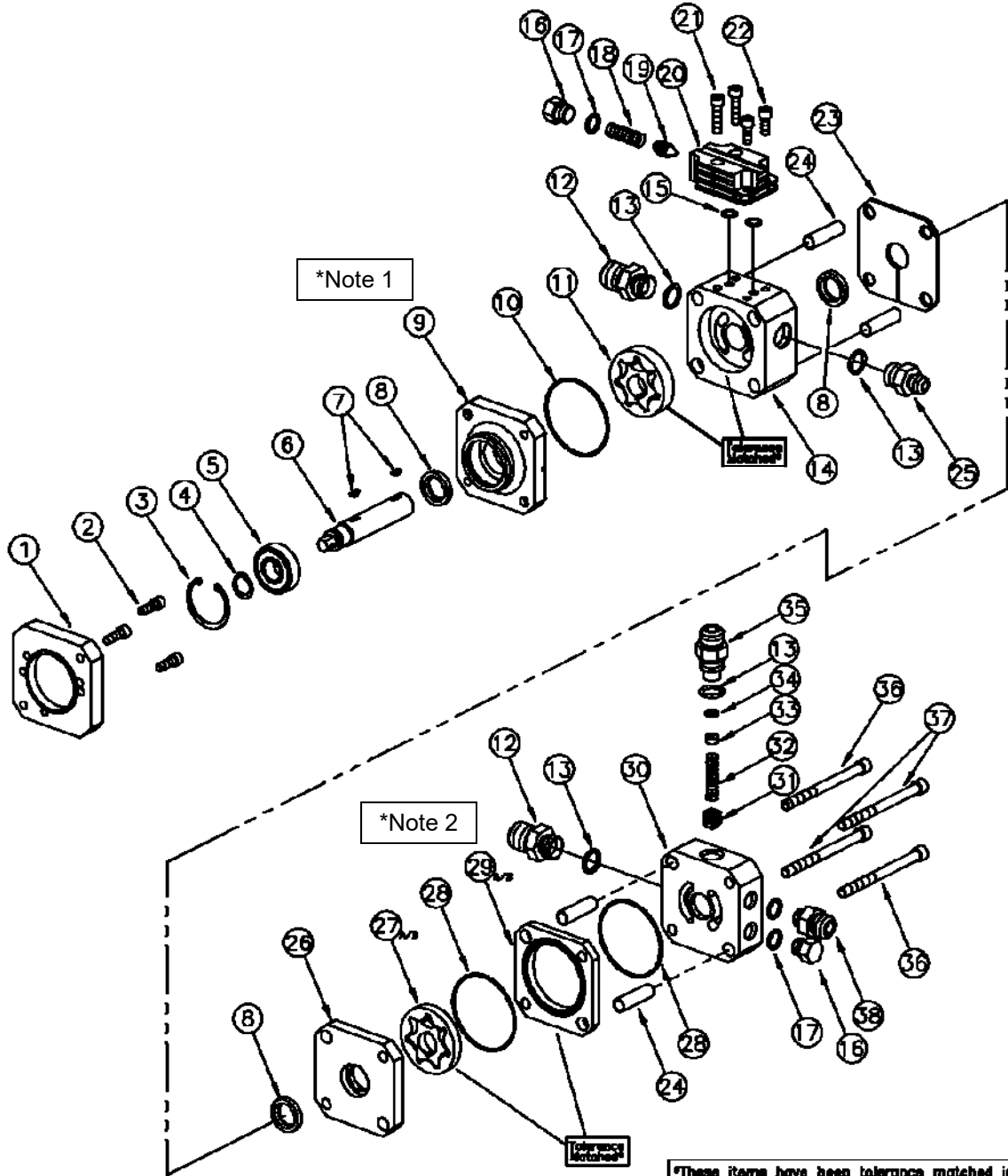

- *It is critical to assemble the components in the correct orientation as shown in order to avoid seal damage.
 *Note 1: Pump SN# should be oriented towards top of pump with "notch" positioned towards pressure fitting.
 *Note 2: Fuel section eccentric should be located towards top of pump as shown (Item #29).

Tandem Pump Rebuild / Seal Kit for SN's Up To 5266 (Includes #5, #7, #8, #10, #15, #28).....KSC1052B
 Tandem Pump Rebuild / Seal Kit for SN's 5267 & Up (Includes #5, #7, #8, #10, #15, #28).....KSC1076B

Technical Information

ITEM	DESCRIPTION.....	PART#
1.	MOUNTING ADAPTOR.....	KSC 1019
2.	¼ X 20 X ¾ SHCS MTG. BOLTS (3 REQ).....	KSM 1003-075
3.	INTERNAL SNAP RING – PUMP.....	KSM 1026-156
4.	EXTERNAL HD SNAP RING.....	KSM 1027-066
5.	DRIVE SHAFT BALL BEARING.....	KSM 1039
6.	DIRECT DRIVE SHAFT (3/8 HEX).....	KSC 1042
7.	WOODRUFF KEY - PUMP.....	KSM 1030-213
8.	SHAFT SEALS (3 REQ).....	KSM1037 (S/N UP TO 5266) KSM1110 (S/N 5267 AND LATER)
9.	P/S BEARING SECTION.....	KSC 1028
10.	P/S BEARING SECTION O’RING.....	KSM 1020-038
11.*	P/S GEROTOR PUMPING ASSEMBLY.....	KSM 1023-500
12.	#8 ORB - #10 JIC FITTING (2 REQ).....	KSM 1059
13.	#8 O’RING (3 REQ).....	KSM 1021-908
14.*	POWER STEERING PUMP BODY.....	KSC 1010
15.	MOUNTED VALVE MTG O’RING (2 REQ).....	KSM 1020-013
16.	RELIEF VALVE CAP (#6 ORB) (2 REQ).....	KSM 1019
17.	#6 O’RING (3 REQ).....	KSM 1021-906
18.	RELIEF VALVE SPRING.....	KSC 1023
19.	RELIEF VALVE POPPET.....	KSC 1031
20.	RELIEF VALVE BODY.....	KSC 1025
21.	RELIEF VALVE BODY BOLT (2 REQ).....	KSM 1004-100
22.	¼ 28 X 1 SHCS RELIEF VALVE BODY BOLT (2 REQ).....	KSM 1004-062
23.	INSULATOR PLATE.....	KSC 1014
24.	HOLLOW DOWEL (4 REQ).....	KSC 1033-149
25.	P/S PRESS. OUT FITTING #8 ORB - #6 JIC.....	KSM 1017
26.	SEPARATOR PLATE.....	KSC 1045
27A.*	FUEL PUMP GEROTOR SET* (1/4").....	KSM 1023-250
	(FOR KSC 1062-002 PUMPS)	
27B.*	FUEL PUMP GEROTOR SET* (5/16").....	KSM 1023-312
	(FOR KSC 1062-004 PUMPS)	
28.	FUEL SECTION SPACER O’RING (2 REQ).....	KSM 1020-037
29A.*	FUEL SECTION SPACER (BRONZE)* (1/4").....	KSC 1041-250
	(FOR KSC 1062-002 PUMPS)	
29B.*	FUEL SECTION SPACER (BRONZE)* (5/16").....	KSC 1041-312
	(FOR KSC 1062-004 PUMPS)	
30.	FUEL PUMP MANIFOLD (INCLUDES SEAT).....	KSC 1046
31.	FUEL BYPASS POPPET.....	KSC 1029
32.	FUEL BYPASS SPRING.....	KSC 1015
33.	FUEL PILL	
	.120 ORFICE.....	KSC1026-120
	.140 ORFICE.....	KSC1026-140
	.160 ORFICE.....	KSC1026-160
	.180 ORFICE.....	KSC1026-180
	.200 ORFICE.....	KSC1026-200
	.220 ORFICE.....	KSC1026-220
	.240 ORFICE.....	KSC1026-240
	BLANK-NO ORFICE.....	KSC1026-000
34.	FUEL BYPASS VALVE O’RING.....	KSM 1020-011
35.	FUEL BYPASS VALVE FITTING (#8).....	KSC 1051
36.	5/16 X 18 X 4 1/4 SHCS ASSY BOLT (2 REQ).....	KSM 1005-425
37.	5/16 X 18 X 3 3/4 SHCS ASSY BOLT (2 REQ).....	KSM 1005-375
38.	FUEL PRESS. OUT FITTING #6 ORB-#8 JIC.....	KSM 1060

*These items are tolerance matched and are recommended to be purchased as a set.

STEERING GEARS

TANDEM PUMPS

FUEL PUMPS

POWER STEERING PUMPS

ACCESSORIES & FLUIDS

WATER PUMPS FRONT COVERS

SERVICE

TECHNICAL INFO

Technical Information

KSC1064-XXX Belt Drive TandemX Pump

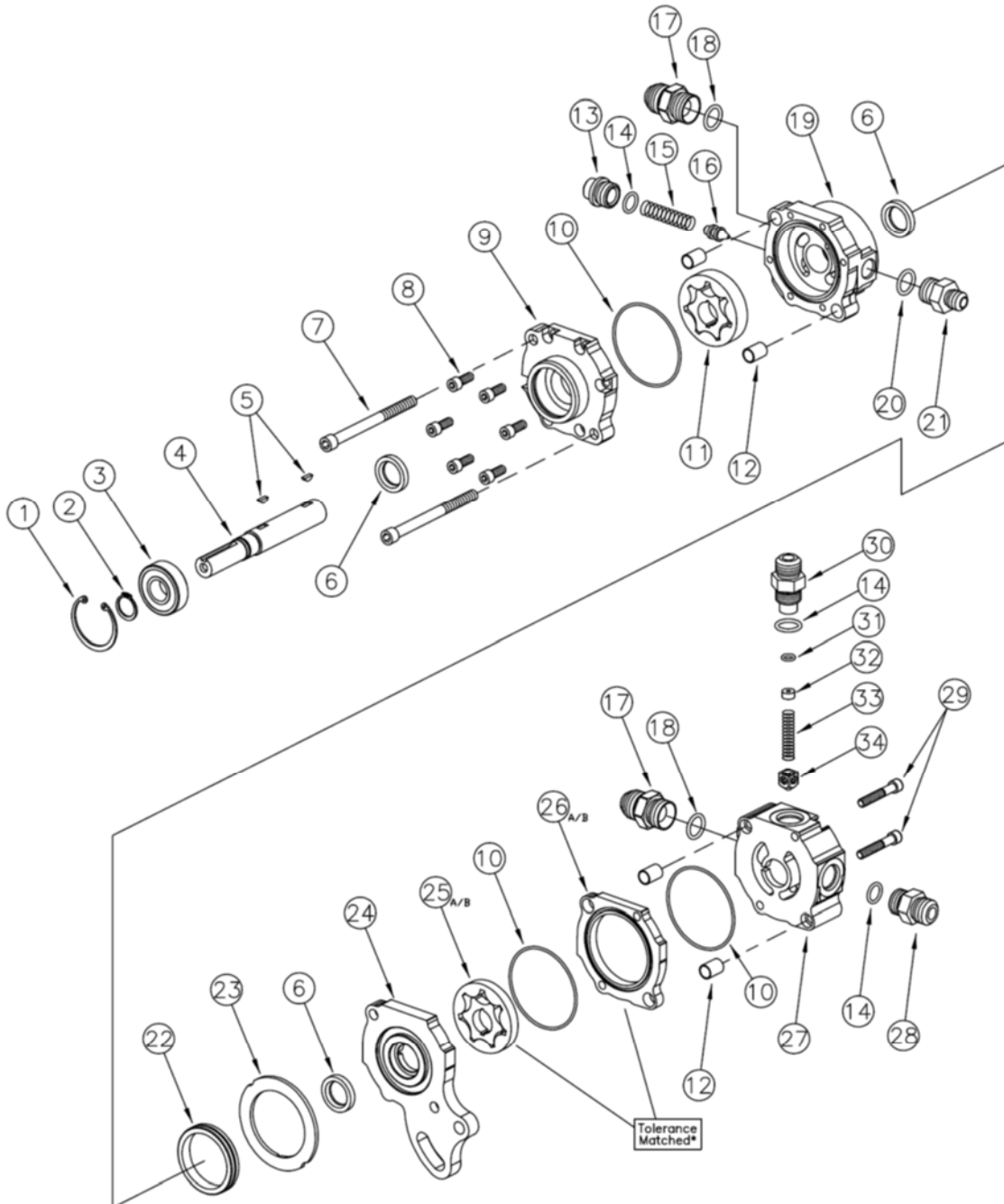

*These items have been tolerance matched in the assembly process and are recommended to be purchased as a mated set.

STEERING GEARS

TANDEM PUMPS

FUEL PUMPS

POWER STEERING PUMPS

ACCESSORIES & FLUIDS

WATER PUMPS FRONT COVERS

SERVICE

TECHNICAL INFO

Technical Information

ITEM	DESCRIPTION.....	PART #
1.	SHAFT & BEARING RETAINING RING.....	KSM1026-156
2.	DRIVE SHAFT BEARING RETAINING RING.....	KSM1027-066
3.	DRIVE SHAFT BALL BEARING.....	KSM1039
4.	BELT DRIVE SHAFT.....	KSC1007
5.	PUMP WOODRUFF KEY (2 REQ).....	KSM1030-213
6.	SHAFT SEALS (3 REQ).....	KSM1110
7.	5/16-18 UNC X 3-3/4" SHCS ASSY BOLT (2 REQ).....	KSM1005-375
8.	1/4-20 UNC X 5/8" SHCS (6 REQ).....	KSM1003-062
9.	HPD BEARING SECTION.....	KSC1064
10.	BEARING & FUEL SECTION O-RING (3 REQ).....	KSM1020-037
11.	P/S GEROTER PUMPING ASSEMBLY.....	KSM1023-500
12.	HOLLOW DOWELL (4 REQ).....	KSC1033-060
13.	RELIEF VALVE CAP (8 ORB).....	KSM1066
14.	#8 O-RING (3 REQ).....	KSM1021-908
15.	RELIEF VALVE SPRING.....	KSC1023
16.	RELIEF VALVE POPPET.....	KSC1031
17.	INLET FITTING #10 ORB-#10 JIC (2 REQ).....	KSM1073
18.	#10 O-RING (2 REQ).....	KSM1021-910
19.	HPD DOUBLE ENDED PUMP BODY.....	KSC1065
20.	#6 O-RING.....	KSM1021-906
21.	PRESSURE FITTING #6 ORB-#6 JIC.....	KSM1016
22.	PRIMARY DOWELL.....	KSC1018
23.	INSULATOR PLATE.....	KSC1013
24.	BELT DRIVE SEPERATOR.....	KSC1024
25.*	FUEL PUMP GEROTER SET FOR PUMPS	
	KSC1064-002 (1/4").....	KSM1023-250
	KSC1064-004 (5/16").....	KSM1023-312
26.*	FUEL SECTION SPACER (BRONZE) FOR PUMP	
	KSC1064-002 (1/4").....	KSC1040-250
	KSC1064-004 (5/16").....	KSC1040-312
27.	FUEL PUMP MANIFOLD (INCLUDES SEAT).....	KSC1048
28.	PRESSURE FITTING #8 ORB-#8 JIC.....	KSM1018
29.	1/4-20 X 1-1/2" SHCS ASSY BOLT (2 REQ).....	KSM1003-150
30.	FUEL BYPASS VALVE FITTING.....	KSC1051
31.	FUEL BYPASS VALVE FITTING PILL O-RING.....	KSM1020-011
32.	FUEL PILL	
	.120 ORFICE.....	KSC1026-120
	.140 ORFICE.....	KSC1026-140
	.160 ORFICE.....	KSC1026-160
	.180 ORFICE.....	KSC1026-180
	.200 ORFICE.....	KSC1026-200
	.220 ORFICE.....	KSC1026-220
	.240 ORFICE.....	KSC1026-240
	BLANK-NO ORFICE.....	KSC1026-000
33.	FUEL BYPASS VALVE SPRING.....	KSC1015
34.	FUEL BYPASS VALVE POPPET.....	KSC1029

*These items are tolerance matched and are recommended to be purchased as a set.

TandemX Pump Rebuild / Seal Kit (Includes #3, #5, #6, #10).....KSC1077B

STEERING GEARS

TANDEM PUMPS

FUEL PUMPS

POWER STEERING PUMPS

ACCESSORIES & FLUIDS

WATER PUMPS FRONT COVERS

SERVICE

TECHNICAL INFO

Technical Information

KSC1065-XXX Direct Drive TandemX Pump

STEERING GEARS

TANDEM PUMPS

FUEL PUMPS

POWER STEERING PUMPS

ACCESSORIES & FLUIDS

WATER PUMPS FRONT COVERS

SERVICE

TECHNICAL INFO

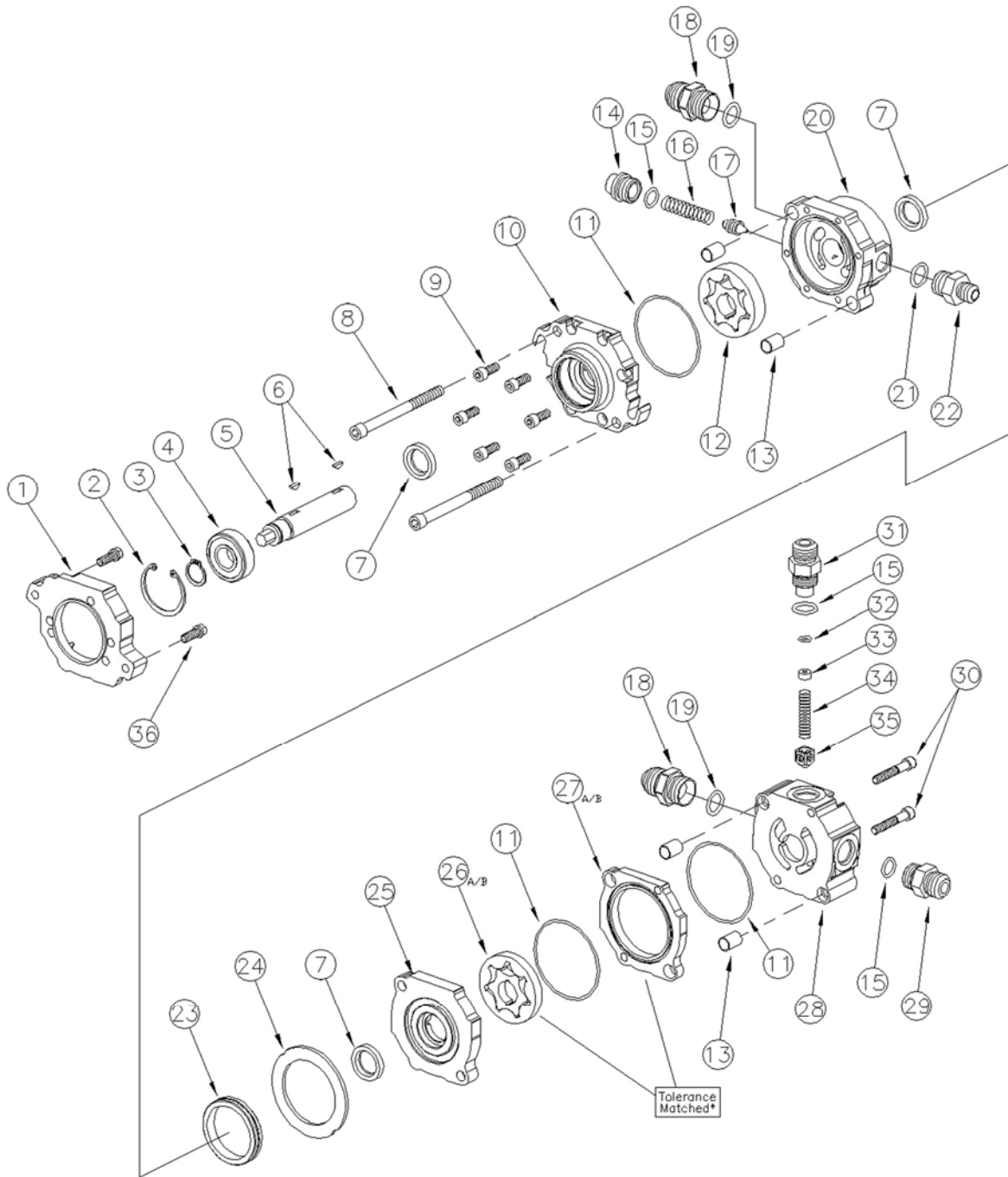

*These items have been tolerance matched in the assembly process and are recommended to be purchased as a mated set.

Technical Information

ITEM	DESCRIPTION.....	PART #
1.	PUMP ADAPTOR	KSC1036
2.	SHAFT & BEARING RETAINING RING.....	KSM1026-156
3.	DRIVE SHAFT BEARING RETAINING RING	KSM1027-066
4.	DRIVE SHAFT BALL BEARING	KSM1039
5.	DIRECT DRIVE SHAFT (3/8" HEX).....	KSC1042
6.	PUMP WOODRUFF KEY (2 REQ).....	KSM1030-213
7.	SHAFT SEALS (3 REQ)	KSM1110
8.	5/16-18 UNC X 3-3/4" SHCS ASSY BOLT (2 REQ).....	KSM1005-375
9.	1/4-20 UNC X 5/8" SHCS (6 REQ)	KSM1003-062
10.	DIRECT DRIVE BEARING SECTION	KSC1035
11.	BEARING & FUEL SECTION O-RING (3 REQ).....	KSM1020-037
12.	P/S GEROTER PUMPING ASSEMBLY	KSM1023-500
13.	HOLLOW DOWELL (4 REQ).....	KSC1033-060
14.	RELIEF VALVE CAP (8 ORB).....	KSM1066
15.	#8 O-RING (3 REQ).....	KSM1021-908
16.	RELIEF VALVE SPRING	KSC1023
17.	RELIEF VALVE POPPET	KSC1031
18.	INLET FITTING #10 ORB-#10 JIC (2 REQ).....	KSM1073
19.	#10 O-RING (2 REQ).....	KSM1021-910
20.	HPD DOUBLE ENDED PUMP BODY	KSC1065
21.	#6 O-RING	KSM1021-906
22.	PRESSURE FITTING #6 ORB-#6 JIC.....	KSM1016
23.	PRIMARY DOWELL	KSC1018
24.	INSULATOR PLATE	KSC1013
25.	DIRECT DRIVE SEPERATOR	KSC1030
26.*	FUEL PUMP GEROTER SET FOR PUMPS	
	KSC1064-002 (1/4").....	KSM1023-250
	KSC1064-004 (5/16").....	KSM1023-312
27.*	FUEL SECTION SPACER (BRONZE) FOR PUMP	
	KSC1064-002 (1/4").....	KSC1040-250
	KSC1064-004 (5/16").....	KSC1040-312
28.	FUEL PUMP MANIFOLD (INCLUDES SEAT).....	KSC1048
29.	PRESSURE FITTING #8 ORB-#8 JIC.....	KSM1018
30.	1/4-20 X 1-1/2" SHCS ASSY BOLT (2 REQ).....	KSM1003-150
31.	FUEL BYPASS VALVE FITTING.....	KSC1051
32.	FUEL BYPASS VALVE FITTING PILL O-RING	KSM1020-011
33.	FUEL PILL	
	.120 ORFICE.....	KSC1026-120
	.140 ORFICE.....	KSC1026-140
	.160 ORFICE.....	KSC1026-160
	.180 ORFICE.....	KSC1026-180
	.200 ORFICE.....	KSC1026-200
	.220 ORFICE.....	KSC1026-220
	.240 ORFICE.....	KSC1026-240
	BLANK-NO ORFICE	KSC1026-000
34.	FUEL BYPASS VALVE SPRING	KSC1015
35.	FUEL BYPASS VALVE POPPET	KSC1029
36.	D/D PUMP MOUNTING SCREWS	KSM1005-100

*These items are tolerance matched and are recommended to be purchased as a set.

TandemX Pump Rebuild / Seal Kit (Includes #4, #6, #7, #11).....KSC1077B

STEERING GEARS

TANDEM PUMPS

FUEL PUMPS

POWER STEERING PUMPS

ACCESSORIES & FLUIDS

WATER PUMPS FRONT COVERS

SERVICE

TECHNICAL INFO

Technical Information

KSD10-1XXX Front Cover Water Pump Assembly—Standard KSD1001 Water Pump Assembly—Standard

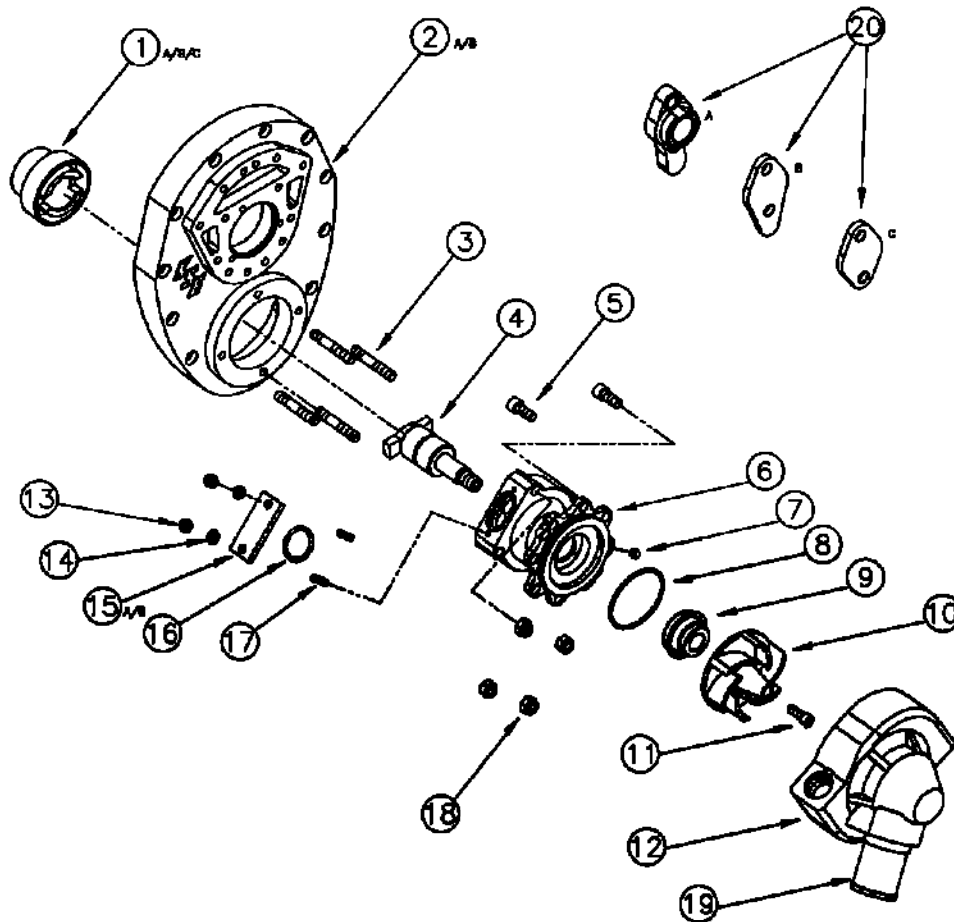

ITEM	DESCRIPTION	PART#
1A.	CHEVY S/B CRANK DRIVE (STEEL)	KSD 1011
1B.	CHEVY S/B CRANK DRIVE LIGHT (ALUM.)	KSD 1011L
1C.	CHEVY B/B CRANK DRIVE (ALUM.)	KSD 1093
2A.	ALUM. FRONT COVER S.B. CHEVY (W/O PAN LIP)	KSD 1002
2B.	BILLET ALUM. FRONT COVER S.B. CHEVY (W/O PAN LIP)	KSD 1003
3.	5/16 - 18 WATER PUMP STUD (4 REQ)	KSM 1011-200
4.	WATER PUMP SHAFT / TANG ASSY	KSD 1076
5.	5/16 - 18 X 3/4" SHCS (2 REQ)	KSM 1005-075
6.	WATER PUMP NECK	KSD 1004
7.	1/4 - 28 X 1/4" SHAFT BEARING SET SCREW	KSM 1009-025
8.	WATER PUMP HOUSING O-RING SEAL	KSM 1020-149
9.	WATER SEAL	KSM 1031
10.	JR. WATER PUMP IMPELLER	KSD 1089
11.	IMPELLER BOLT 1/4 X 20 X 3/4" SHCS LHT.	KSM 1007-075
12.	WATER PUMP HOUSING	KSD 1005
13.	TIMING WINDOW 10-24 NYLOK NUT (2 REQ)	KSM 1048-170
14.	10-24 FLAT WASHER (2 REQ)	KSM 1045-010
15A.	LEXAN TIMING WINDOW	KSD 1013
15B.	ALUMINUM TIMING WINDOW	KSD 1012
16.	TIMING WINDOW O-RING	KSM 1020-120
17.	10-24 X 3/4" TIMING WINDOW STUD (2 REQ)	KSM 1008-075
18.	5/16 - 18 NYLOK NUT (4 REQ)	KSM 1047-312
19.	INLET TUBE (NOT SERVICEABLE)	KSD 1006
20A.	HOSE BLOCK MOUNTS (2 REQ)	KSD 1009
20B.	WATER PUMP BLOCK OFF (LONG) (1 REQ)	KSD 1027
20C.	WATER PUMP BLOCK OFF (SHORT) (1 REQ)	KSD 1028

Technical Information

KSD10-2XXXX Front Cover Water Pump Assembly—HPD KSD1057 Water Pump Assembly—HPD

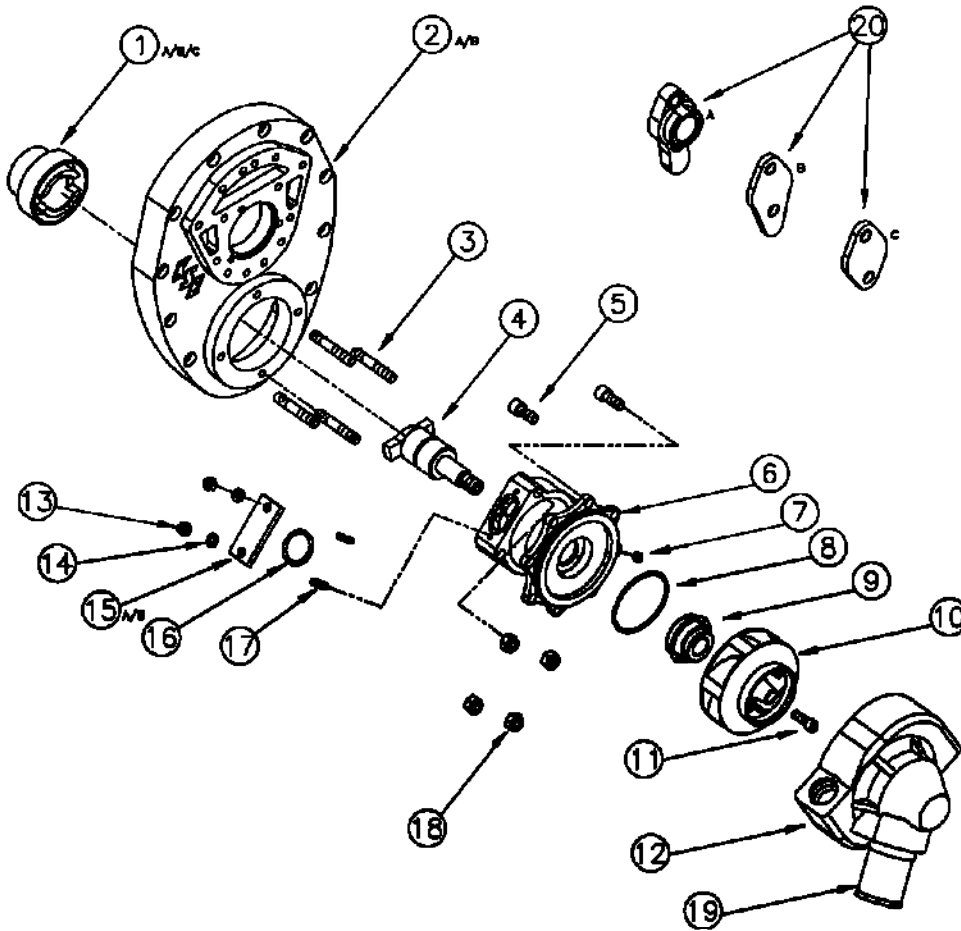

ITEM	DESCRIPTION	PART#
1A.	CHEVY S/B CRANK DRIVE (STEEL)	KSD 1011
1B.	CHEVY S/B CRANK DRIVE LIGHT (ALUM.)	KSD 1011L
1C.	CHEVY B/B CRANK DRIVE (ALUM.)	KSD 1093
2A.	ALUM. FRONT COVER S.B. CHEVY (W/O PAN LIP)	KSD 1002
2B.	BILLET ALUM. FRONT COVER S.B. CHEVY (W/O PAN LIP)	KSD 1003
3.	5/16 - 18 WATER PUMP STUD (4 REQ)	KSM 1011-200
4.	WATER PUMP SHAFT / TANG ASSY	KSD 1076
5.	5/16 -18 X 3/4" SHCS (2 REQ)	KSM 1005-075
6.	WATER PUMP NECK	KSD 1055
7.	1/4 - 28 X 1/4" SHAFT BEARING SET SCREW	KSM 1009-025
8.	WATER PUMP HOUSING O-RING SEAL	KSM 1020-151
9.	WATER SEAL	KSM 1031
10.	PUMP IMPELLER	KSD 1035
11.	IMPELLER BOLT 1/4 X 20 X 3/4" SHCS LHT	KSM 1007-075
12.	WATER PUMP HOUSING	KSD 1034
13.	TIMING WINDOW 10-24 NYLOK NUT (2 REQ)	KSM 1048-170
14.	10-24 FLAT WASHER (2 REQ)	KSM 1045-010
15A.	LEXAN TIMING WINDOW	KSD 1013
15B.	ALUMINUM TIMING WINDOW	KSD 1012
16.	TIMING WINDOW O-RING	KSM 1020-120
17.	10-24 X 3/4" TIMING WINDOW STUD (2 REQ)	KSM 1008-075
18.	5/16 - 18 NYLOK NUT (4 REQ)	KSM 1047-312
19.	INLET TUBE (NOT SERVICEABLE)	KSD 1056
20A.	HOSE BLOCK MOUNTS (2 REQ)	KSD 1009
20B.	WATER PUMP BLOCK OFF (LONG) (1 REQ)	KSD 1027
20C.	WATER PUMP BLOCK OFF (SHORT) (1 REQ)	KSD 1028

STEERING GEARS

TANDEM PUMPS

FUEL PUMPS

POWER STEERING PUMPS

ACCESSORIES & FLUIDS

WATER PUMPS FRONT COVERS

SERVICE

TECHNICAL INFO