

TYPHOON INTAKE SYSTEMS



Warning: Please follow these installation instructions carefully. The K&N Drycharger included with this kit must be installed on the K&N air filter when used with a K&N Typhoon Cold Air Intake System. The K&N Typhoon Intake System is a performance product that can be used safely during mild weather conditions. During harsh and inclement weather conditions, you must convert your Cold Air Intake System to a short ram configuration, or return your vehicle to the stock OEM airbox and intake tract configuration. Failure to follow these instructions can void your warranty.

INSTALLATION INSTRUCTIONS

69-3512

Ford
2003-07 Focus
L4-2.3L

TOOLS NEEDED:

Flat Blade Screwdriver
Ratchet
10mm socket
13mm end wrench
2.5mm Allen wrench
T20 Torx driver

Prior to the installation process, please inspect the contents of this package to ensure that all parts are included in this kit. Please see parts list for description and quantities.

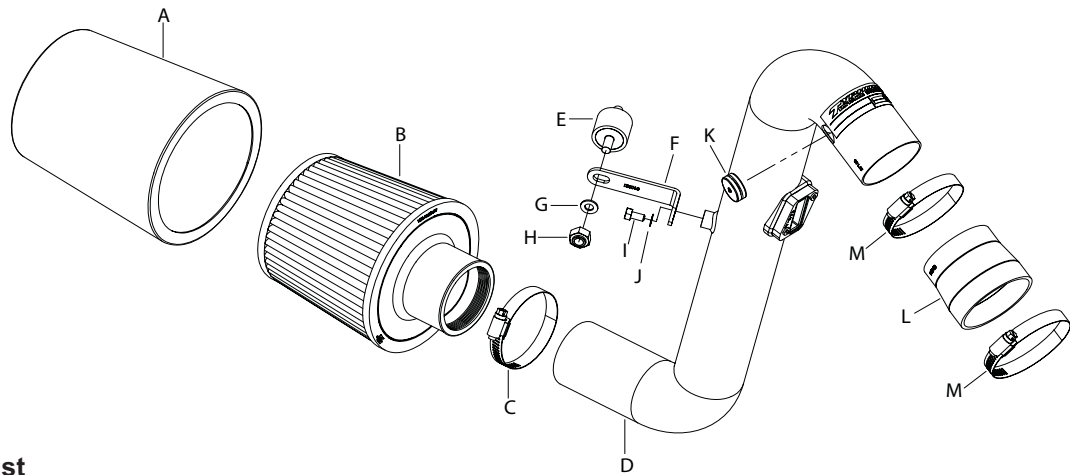

Parts List

Description	Qty.	P/N	Description	Qty.	P/N
A DRYCHARGER; 5-1/2" T, BLACK	1	RX-4990DK	I BOLT; M6-1.00 X 12MM, SS	1	07727
B AIR FILTER	1	KRU4950E	J WASHER; 6MM WAVE	1	08277
C HOSE CLAMP #40	1	08554	K GROMMET; RUBBER	1	08053
D COLD AIR INTAKE TUBE	1	27168	L HOSE; 2-1/2" ID TO 2-3/4" OD X 2" L, BLACK	1	084016
E STUD; RUBBER MOUNT 8MM	1	070227	M HOSE CLAMP #44	2	08560
F BRACKET; "L" LONG, 69-3512, STL FB/PC	1	010051			
G WASHER; 8MM WAVE, SS	1	08272			
H NUT; 8MM NYLOCK, SS	1	07503			

TO START:

1. Turn the ignition OFF and disconnect the vehicle's negative battery cable.



2. Depress the green locking tab on the crank case vent hose and then pull the vent hose to disconnect from the fitting as shown.



3. Loosen the hose clamp, which secures the factory intake tube to the throttle body.

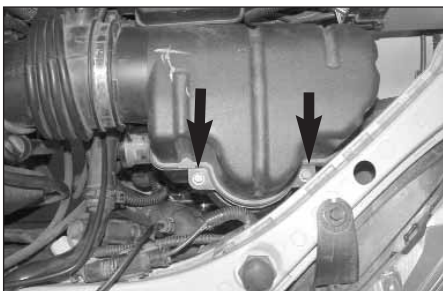

4. Loosen the two bolts, which secure the upper intake housing to the mass air sensor housing. **NOTE: The two bolts do not separate from the upper intake housing.**



5. Lift firmly to separate the upper intake housing from the mass air sensor housing and then remove the upper intake housing from the vehicle.



6. Depress the locking tab on the mass air sensor electrical connection and then disconnect the electrical connection.



7. Loosen the hose clamp, which secures the mass air sensor housing to the lower intake housing.

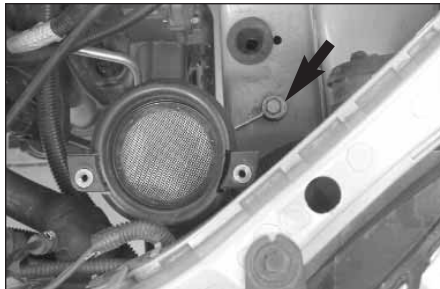

8. Remove the bolt, which secures the mass air sensor housing bracket to the inner fender.



9. Pull firmly up and remove the mass air sensor assembly from the vehicle.

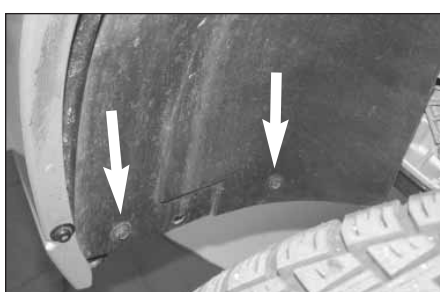

10. After jacking up the car and placing on suitable jack stands and chocking the rear wheels, remove the two bolts which secure the air box on equipped vehicle's or the one bolt on splash shield equipped vehicle's to the inner fender well.

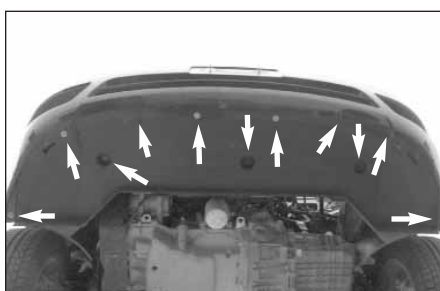

10a. On vehicle's equipped with the splash shield, remove the six bolts and five plastic screws which secure the splash shield to the bumper cover, then remove the splash shield from the vehicle.

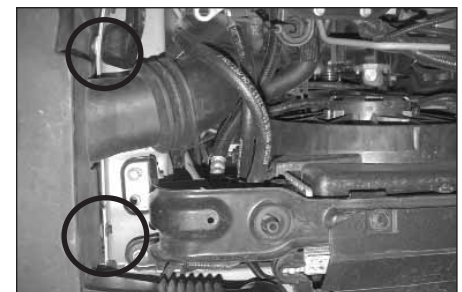

11. On vehicle's equipped with an air box cover, remove the two bolts which secure the cover to the frame rail, and the bolt which secures the intake snorkel to the radiator core support.



12. On vehicles equipped with an air box cover, lower the cover and remove it from the vehicle.

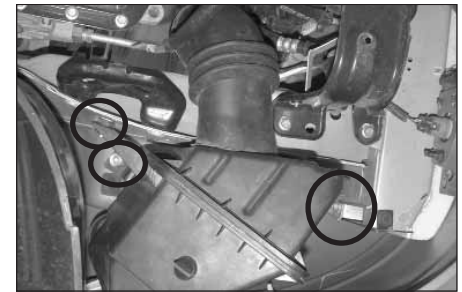

13. Remove the three bolts which secure the lower air box to the inner fender well.



14. Lower and remove the air box assembly from the vehicle.

NOTE: On vehicles equipped with the intake snorkel on top of the air box behind the fender, it will be necessary to separate the snorkel from the air box during air box removal.



14a. On vehicle's equipped with the upper intake snorkel, pull down on the snorkel to dislodge it from the mount and then remove it from behind the fender.



15. Install the supplied rubber mounted stud to the factory threaded hole as shown.



16. Remove the mass air sensor from the stock secondary tube.



17. Install the supplied "L" bracket and hardware to the K&N® intake kit. Do not tighten completely. **NOTE: Before installing the "L" bracket, inspect the inside of the tube for any debris, then clean the inside out with water and a towel. Inspect the tube one more time before proceeding to the next step.**



18. Install the supplied rubber grommet into the intake tube as shown.



19. Using the stock bolts removed in step # 13, install the mass air sensor into the intake tube as shown.



20. Install the supplied silicone hose and hose clamps onto the throttle body and tighten only the hose clamp over the throttle body.

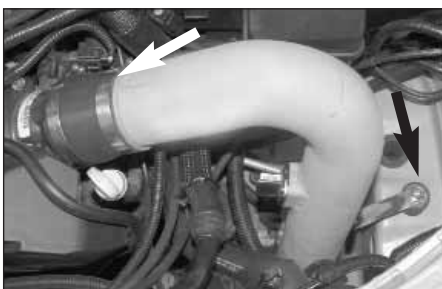

20. Install the intake tube into the vehicle by inserting one end onto the throttle body silicone hose then making sure that the "L" bracket lines up onto the rubber mounted stud.

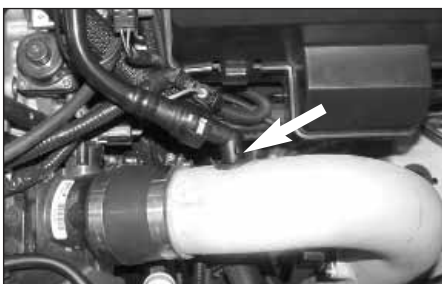

21. Insert the crankcase vent line into the rubber grommet on the intake tube as shown.

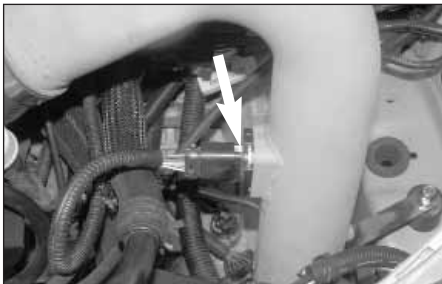

22. Re-connect the mass air sensor electrical connection as shown.



23. Install the K&N Drycharger onto the K&N Air filter as shown.

NOTE: The Drycharger's water repellent properties will last up to two years. See the parts list to re-order Drycharger if necessary.



24. From underneath the vehicle, install the K&N® air filter onto the intake tube and tighten hose clamp completely.



25. On vehicle's that were equipped with an air box cover, reinstall and secure with the bolts that were removed in step #11.



26. On vehicle's that were equipped with the splash shield, reinstall with the bolts removed in step #10a.

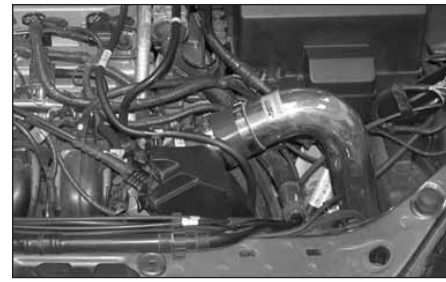

27. Reconnect the negative battery cable and double check to make sure everything is tightened and properly positioned before starting the vehicle.

28. It will be necessary for all Typhoons to be checked periodically for realignment, clearance and tightening of all connections. Failure to follow the above instructions or proper maintenance may void warranty.

ROAD TESTING:

1. Start the engine with the transmission in neutral or park, and the parking brake engaged. Listen for air leaks or odd noises. For air leaks secure hoses and connections. For odd noises, find cause and repair before proceeding. This kit will function identically to the factory system except for being louder and much more responsive.
2. Test drive the vehicle. Listen for odd noises or rattles and fix as necessary.
3. If road test is fine, you can now enjoy the added power and performance from your kit.
4. K&N suggests checking the Air filter element periodically for excessive dirt build-up. When the element becomes covered in dirt (or once a year), service it according to the instructions on the Recharger service kit, part number 99-5000 or 99-5050.

FREE K&N DECAL To register your warranty, please see us online at knfilters.com/register. FREE K&N DECAL