

FABTECH



JEEP® JK



TABLE OF CONTENTS

TECH

| | |
|--------------------|---------|
| CRAWLER - LONG ARM | 6 - 9 |
| TRAIL - SHORT ARM | 10 - 11 |
| COILOVERS | 12 - 13 |
| COIL SPRINGS | 14 - 15 |
| SHOCKS | 16 - 19 |

APPLICATIONS

| | |
|-----------------|---------|
| CRAWLER SYSTEMS | 22 - 35 |
| TRAIL SYSTEMS | 36 - 41 |
| SPORT SYSTEMS | 42 - 43 |
| SPACER SYSTEMS | 44 - 45 |

| | |
|-------------|---------|
| ACCESSORIES | 46 - 55 |
|-------------|---------|



With over 27 years of experience in building the finest suspension systems and shocks, Fabtech launches into the Jeep market with 60 new suspensions and a multitude of accessories.

While many associate Fabtech with light truck suspension, the R&D team at Fabtech has been working behind the scenes on Jeep suspension for years. Designing and testing, over and over in all types of terrain. This experience has culminated in the finest and most reliable suspension designs for the Jeep enthusiast.

Fabtech offers multiple levels of suspension in complete packages for ease of ordering and correct functionality, right out of the box. Many of the suspension components are available separately for those that want to build as you go. Cutting edge, heavy duty new products include the Fabtech 5 Ton Joint™ and lower Link Arms that come with lifetime warranties, more proof of Fabtech's commitment to building the finest suspensions.

When you want a premium suspension for your Jeep, from the undisputed leader in quality, get Fabtech.

SUSPENSION SYSTEM GUIDE

CRAWLER™ COILOVER

FRONT - LONG ARM / COILOVERS

REAR - LONG ARM / COIL SPRINGS

APPLICATIONS - PAGES 24-25

Advanced suspension performance for demanding drivers. Best all around Long Arm system.

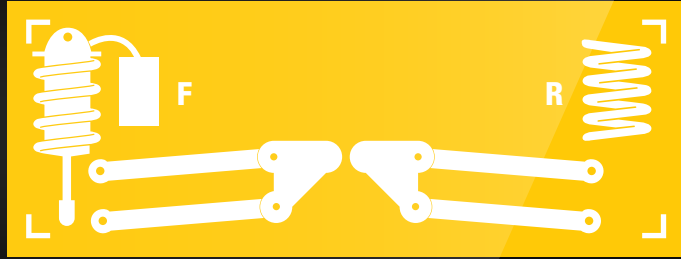

CRAWLER™ COILOVER II

FRONT - LONG ARM / COILOVERS

REAR - LONG ARM / COILOVERS

APPLICATIONS - PAGES 28-29

Top level exotic system for maximum offroad performance. Hardcore to highway.

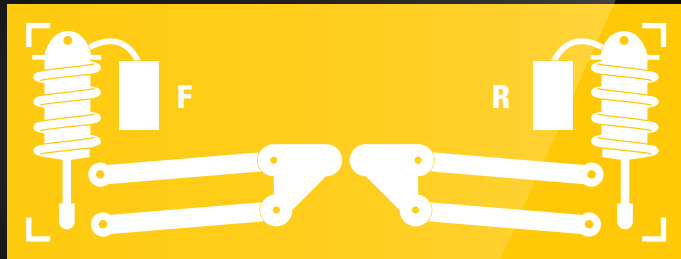

CRAWLER™ STANDARD SPRINGS

FRONT - LONG ARM / STANDARD COIL SPRINGS

REAR - LONG ARM / STANDARD COIL SPRINGS

APPLICATIONS - PAGE 32

Superior coil spring suspension system.

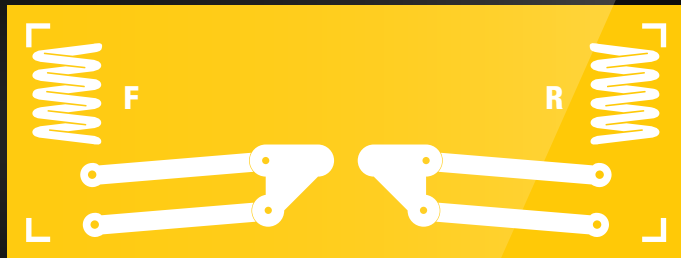

CRAWLER™ LONG TRAVEL SPRINGS

FRONT - LONG ARM / LONG TRAVEL COIL SPRINGS

REAR - LONG ARM / LONG TRAVEL COIL SPRINGS

APPLICATIONS - PAGES 34-35

Excellent performing full coil spring system without having to step into Coilovers.

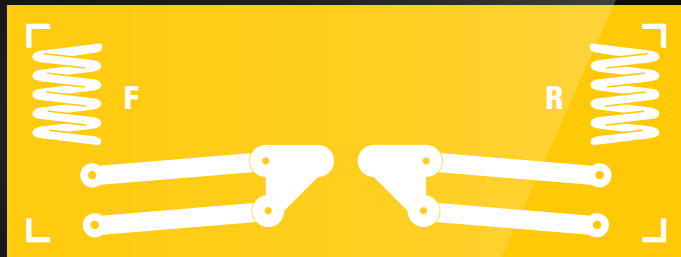

TRAIL

STANDARD SPRINGS

FRONT - SHORT ARM / STANDARD COIL SPRINGS

REAR - SHORT ARM / STANDARD COIL SPRINGS

APPLICATIONS - PAGES 38-39

Upgraded suspension performance for on and offroad.

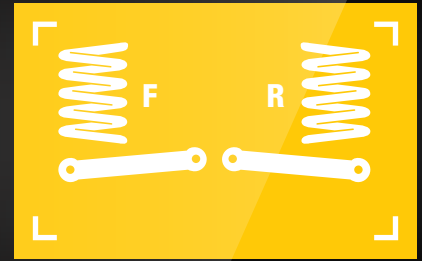

TRAIL

LONG TRAVEL SPRINGS

FRONT - SHORT ARM / LONG TRAVEL COIL SPRINGS

REAR - SHORT ARM / LONG TRAVEL COIL SPRINGS

APPLICATIONS - PAGES 40-41

Outstanding performance. Best overall Short Arm suspension for all variants of on and offroad use.

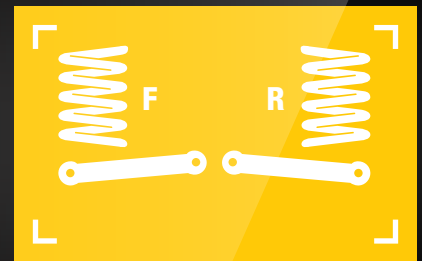

SPORT

STANDARD SPRINGS

FRONT - STANDARD COIL SPRINGS

REAR - STANDARD COIL SPRINGS

APPLICATIONS - PAGES 42-43

Great entry level system for increased damping with additional ride height.

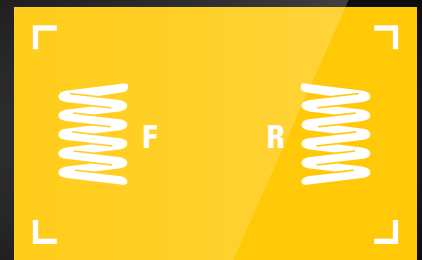

SPACER

FRONT - COIL SPACERS

REAR - COIL SPACERS

APPLICATIONS - PAGES 44-45

Provides increased ride height for larger tires.

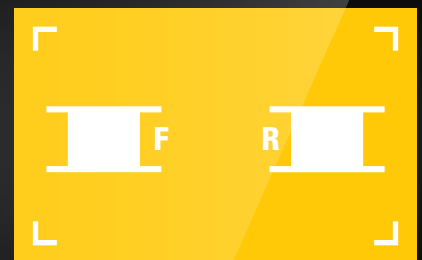



CRAWLER™ LONG ARM DESIGN

There are many types of solid axle link suspension configurations that Fabtech has built over the years for a variety of applications. When testing all possible configurations, the experts at Fabtech determined that a 4 Link with a track bar is superior on a JK for highway and offroad.

The 4 Link design provides the best ride, best handling, and the most articulation and suspension travel overall. While there are other long arm, 3 link, radius arm systems on the market, these do not provide the reduced caster change and useable articulation on a JK, with the factory gas tank, that a Fabtech 4 Link long arm system can.

Fabtech's Crawler™ long arm systems are built to meet the most experienced driver's expectations without having a questionably fabricated suspension. If you are in the market for a system that will work properly right out of the box and does not require continued fabrication and constant maintenance, look no further.

TECH

CRAWLER™ LONG ARM

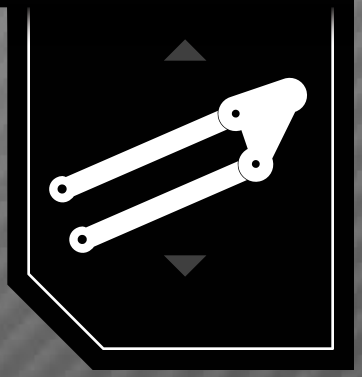
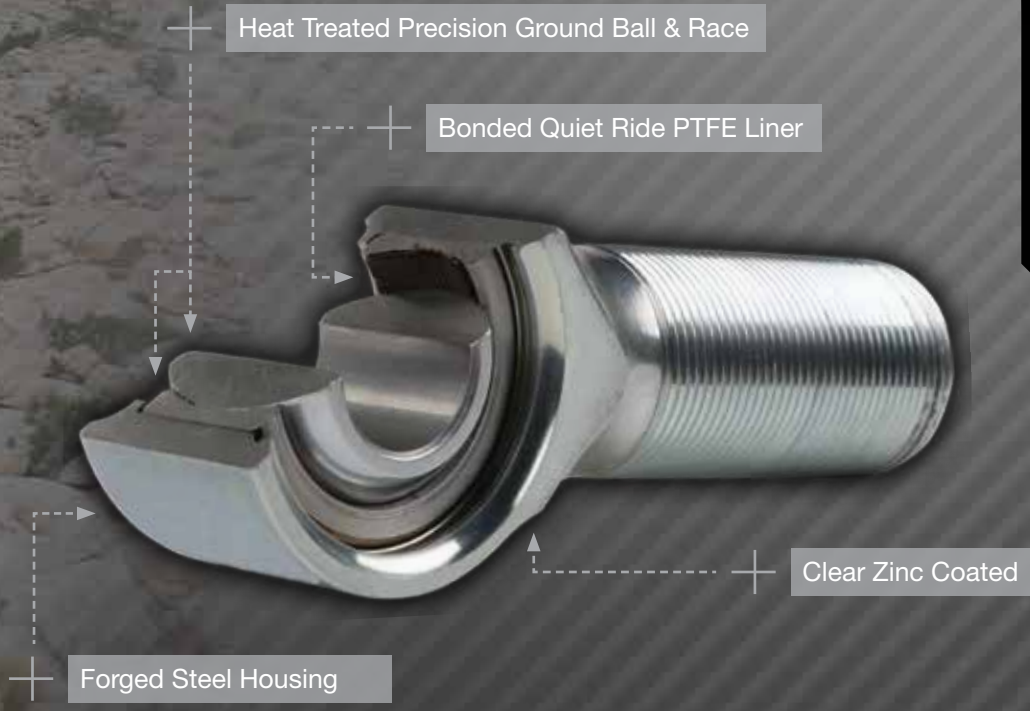

5 TON JOINT™

Fabtech has taken their 5 ton medium duty truck joint, with 15 years of proven use, and adapted it into a Jeep Link Arm joint. The Fabtech 5 Ton Joint™. A heavy duty forged housing that contains a proprietary spherical bearing that will never wear out while providing a quiet ride on the highway. Guaranteed. Yes, each 5 Ton Joint™ comes with a lifetime warranty against wearing out.

- Proprietary spherical bearing proven in 5 Ton medium truck applications for 15 years
- Quiet ride bearing liner
- Polished and plated forged steel housing
- Available thread size - 1.50" & 1.25"
- High misalignments allow for 33 degrees of angle
- Lifetime Warranty against wearing out

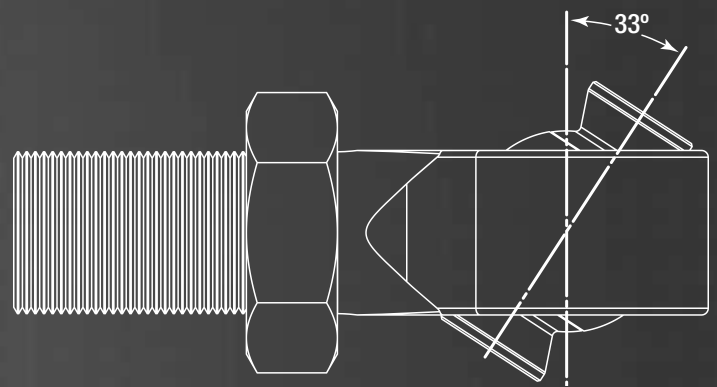



Lower Link Frame Mount

Upper Link Frame Mount

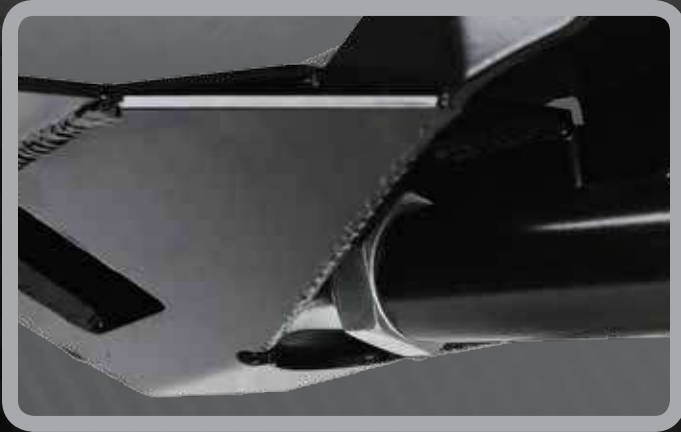

CRAWLER™ LONG ARM LINK DESIGN

Fabtech's Crawler™ Systems replace all eight of the link arms with extended length units to allow for smooth operation at extreme angles. The link arms are mounted up high on the frame to increase ground clearance without the need to bend the links as with other long arm systems on the market.

Construction of the link arms is nothing short of the best heavy duty units you can buy. Each lower link is built from 2" OD .313 thick wall DOM that is so strong Fabtech provides a warranty against bending. Link arms are internally threaded to accept the ground breaking Fabtech 5 Ton Joint™.

The Fabtech 5 Ton Joint™ is comprised of a heavy duty forged housing that contains a proprietary spherical bearing that will never wear out while providing a quiet ride on the highway. Guaranteed.

TECH

CRAWLER™ LONG ARM

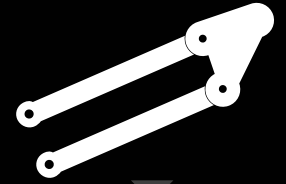

CRAWLER™ LINK MOUNT DESIGN

A key part of the mounting of the Crawler's™ long arm links to the frame is the geometry and ground clearance. The location of the frame side of the link arms is critical in providing superior handling throughout the travel range. Fabtech has found the sweet spot geometry for the link arms that provide a superior driving long arm system compared to all others on the market.

Front link arm mounts are a full crossmember that spans frame rail to frame rail with no welding required for installation. Rear frame mounts attach to the side of the frame and do not require welding or removal of the gas tank for installation.

- Provides maximum articulation and travel without interference to under vehicle components
- Fabtech 5 Ton Joints™ with lifetime warranty
- Proper Link Arm geometry provides excellent on road drive ability
- High ground clearance position with straight Link Arms for ultimate strength
- Lower Link Arms constructed of 2" OD .313 Thick wall tubing guaranteed not to bend
- 1/4" thick steel Track Bar brackets for proper roll center front & rear
- Wheel and articulation travel – Front 12" Rear 12" for both 3" and 5" systems



TRAIL SHORT ARM LINK DESIGN

Fabtech's Trail short arm system utilizes the factory end link pivot cross bolt angle. Unlike most other short arm links the pivot cross bolts are skewed and not line up parallel on each end as the factory arms do. This creates bind and premature bushing wear resulting in poor handling. Fabtech Trail short arm links are correct and eliminate premature bushing wear due to the proper angles.

Fabtech's Trail systems are engineered to provide strength and performance to the vehicle's suspension with a focus on longevity both on and offroad. This makes the system perfect for hardcore trail use and overland expeditions.

FABTECH
Correct parallel joint angles with double bend link for tire clearance

FACTORY
Correct parallel joint angles

OTHERS INCORRECT LINK DESIGN
Joint angles not parallel

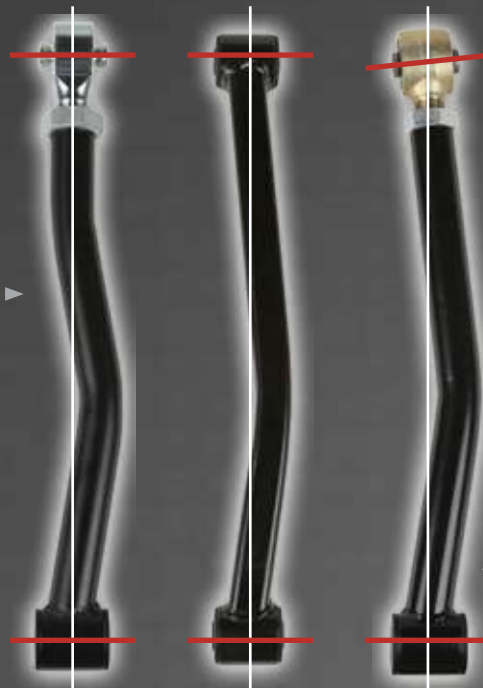

TECH

TRAIL SHORT ARM



TRAIL SHORT ARM DESIGN

The Trail system replaces the four factory lower link arms due to their vulnerability to offroad obstacles. The Fabtech short arm links are heavy duty with .250 thick wall tubing that will not bend under severe offroad use guaranteed.

A key design feature of the Fabtech link arms is the retention of the factory cross bolt pivot angle. This critical angle keeps the link ends parallel to each other thereby reducing bushing wear that can lead to poor handling.

- Long Travel or Standard coil springs option
- Excellent drive ability for overland and heavy duty trail use
- Properly designed link arms reduce bushing wear while providing maximum articulation and travel
- Massive Fabtech 5 Ton Joint™ with lifetime warranty
- Lower Link Arms constructed of 1.75" OD .250 Thick wall tubing guaranteed not to bend
- Optional upper links available separately

5 TON JOINT™

The Fabtech 5 Ton Joint™ is comprised of a heavy duty forged housing that contains a proprietary spherical bearing that will never wear out while providing a quiet ride on the highway. Guaranteed.

- Proprietary spherical bearing proven in 5 Ton medium truck applications for 15 years
- Quiet ride bearing liner
- Polished and plated forged steel housing
- Available thread size - 1.50" & 1.25"
- High misalignments allow for 33 degrees of angle
- Lifetime Warranty against wearing out

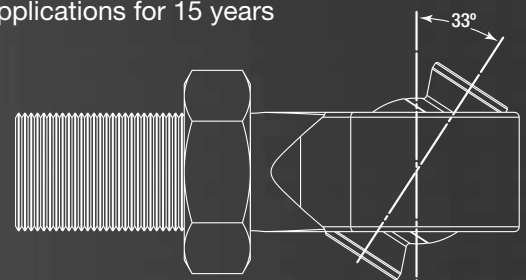



COILOVER CONVERSION SYSTEMS

The front and rear Dirt Logic 2.5 Coilover conversion provides outstanding high speed damping with the ability to crawl at low speed with maximum articulation for big rocks.

The bolt on front Coilover is mounted on top of the centerline of the axle to prevent premature Link Arm bushing wear leading to poor handling.

The rear system features a large one piece sub frame that strengthens the factory frame for coilover use. This allows the vehicle to be driven aggressively without frame damage.

- Front Coilover positioned at centerline of axle to prevent premature bushing wear and poor handling
- Designed for full articulation and lock to lock turning radius clearance
- Rear system sub frame strengthens frame for longevity
- Utilizes large Dirt Logic 2.5 diameter Coilovers
- Allows for 12" of usable wheel and articulation travel
- Available in Crawler™ long arm systems

TECH

COILOVER

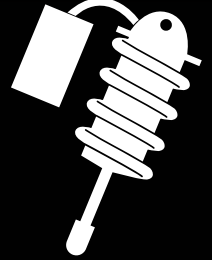

DIRT LOGIC 2.5 COILOVERS

- Stainless Steel body for maximum corrosion resistance
- Eibach dual rate coil springs
- Aluminum reservoir keeps shock cool for consistent damping
- Excellent ride quality on and offroad
- Adjustable ride height

OPTIONS

- Dirt Logic 2.25 Bump Stops for increased damping at full compression - See page 48
- Rear heavy capacity coil springs for additional cargo and trailer towing - See page 46

FABTECH DUAL RATE LONG TRAVEL SPRINGS

The best all around coil springs for Jeep JK's

- + True Dual Rate Long Travel design
- + Comfort ride with carrying capacity
- + Allows for maximum articulation and travel
- + American made quality

1ST STAGE

2ND STAGE

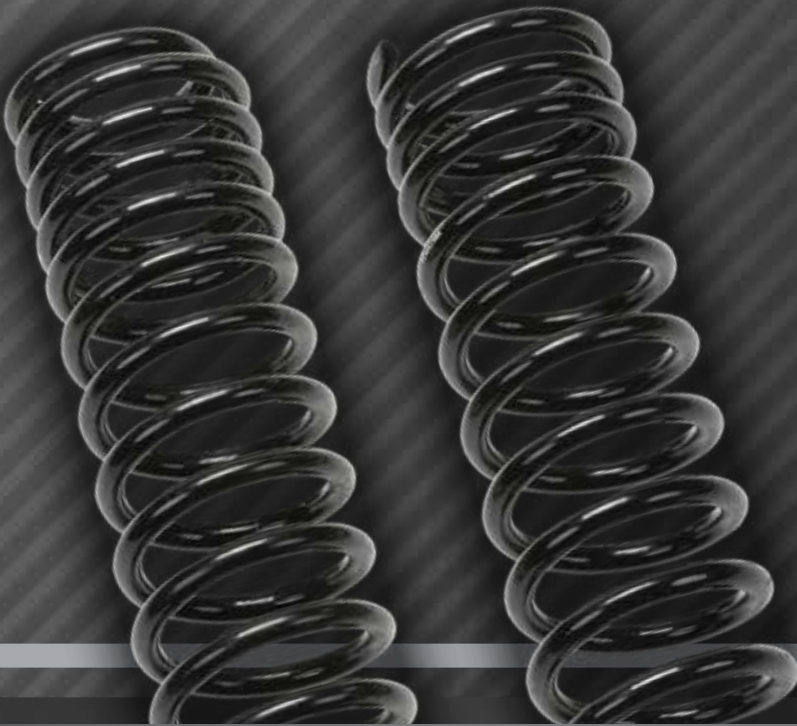

DUAL RATE LONG TRAVEL COIL SPRINGS

These American made coil springs are a true Dual Rate design allowing for long travel suspension use offroad with a smooth highway ride. In the first stage of the spring they provide a soft ride with the ability to extend for long travel range. The second stage is designed to handle the payload of the vehicle and address large impact absorption at higher speeds.

These Dual Rate Long Travel springs have been designed in conjunction with all Fabtech suspension systems and shocks to eliminate the need for spring retainers or limiting straps. They stay seated though out the suspension travel and articulation range. Available in Crawler™ Long Arm and Trail Short Arm systems.

TECH

COIL SPRING

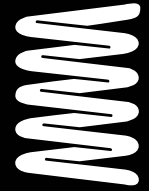

STANDARD COIL SPRINGS

These American made coils springs are designed to increase travel and articulation compared to the stock springs. The single rate design provides same load carrying capacities as factory for either 2 door or 4 door vehicles.

As with the Dual Rate Long Travel springs they do not require spring retainers or limiting straps to stay seated throughout the travel range with Fabtech suspensions and shocks. Available in Crawler™ Long Arm, Trail Short Arm and Sport systems.

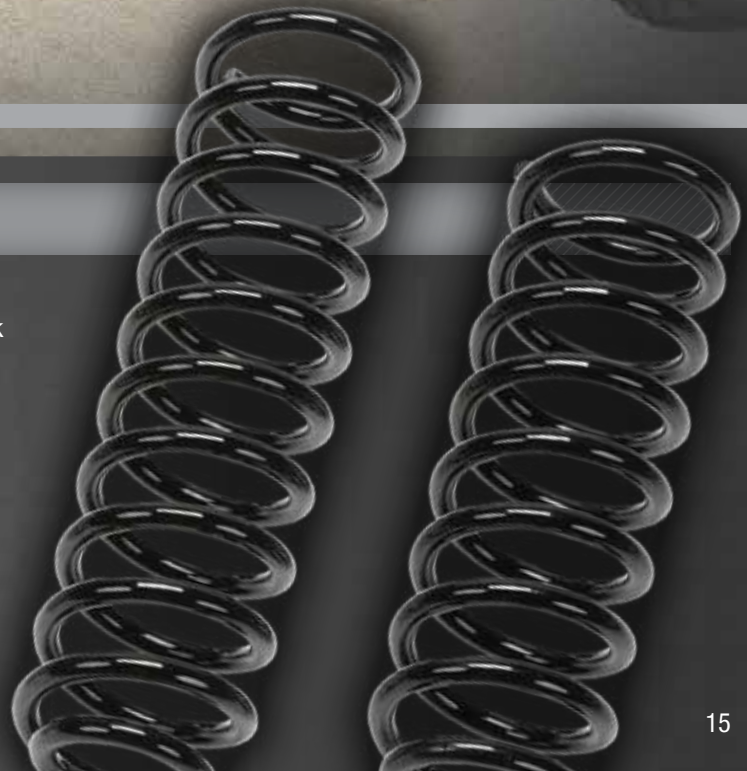



DIRT LOGIC 2.25 SHOCKS

Top quality Dirt Logic 2.25 shocks are built from the finest material to provide maximum corrosion resistance with a superior ride. The stainless steel body will provide years of service in the harshest conditions.

Larger than the market standard of 2.0" OD these shocks have more fluid and a larger piston and rod for aggressive offroad driving. Extensive ride tuning has been performed to provide the finest ride quality both on and offroad. Proudly hand built in Chino, California.

Valved for superior ride quality both on and offroad

2.25" OD Stainless Steel body for maximum corrosion resistance

7/8" OD NitroSteel® piston rod is stronger than chrome rods

Optional aluminum remote resi keeps shock cooler for a consistent ride quality

TECH

SHOCKS

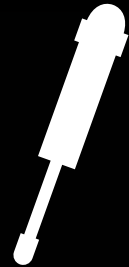

DIRT LOGIC 2.25 BUMPSTOPS

For aggressive high speed offroad driving Dirt Logic 2.25 bump stops will provide increased damping to the suspension at full compression. Front kits are available for use with the factory coil spring and shock configuration or with Dirt Logic Coilover conversion. The rear kit is for custom fabrication requiring frame modification and welding.

FACTORY POSITION



DIRT LOGIC 2.25 STEERING STABILIZER

Provides increased damping for the steering system of the vehicle to reduce tire shake caused by large tires both on and offroad.



STEALTH MONOTUBE SHOCKS

Stealth is the first all black monotube shock absorber, with an identifiable raised metal nameplate, that represents the signature of quality you can rely on for a superior ride at an affordable price.

Each Stealth shock is built with a 46mm diameter high flow piston and valved specifically for Jeep JK's with oversized tires. They feature Nitrocarburized piston rods that are superior to chromed rods in durability and corrosion resistance.

- 50mm OD seamless steel body
- 46mm High flow piston for best ride
- Jeep JK specific valving designed for oversized tires
- 14mm Nitrocarb piston rod resists rock chips and rusting
- All black finish with raised nameplate as a signature of quality

TECH

SHOCKS

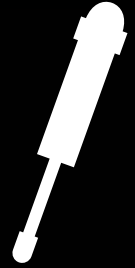

PERFORMANCE TWINTUBE SHOCKS

Fabtech's Performance shocks are a great value and provide a good highway ride with offroad capabilities. The twintube design features an inner tubular chamber that contains the piston and valving. An outer tube serves as the hydraulic reservoir and protects the piston chamber from rock impacts. This twintube construction is one of the most durable shock designs that provides good overall performance.

- Twintube hydraulic construction
- 1-3/8" OD Piston
- 9/16" Hardened chrome piston rod
- Closed cell foam insert
- High flow 9 stage valving



SYSTEMS

& APPLICATIONS





CRAWLER™ LONG ARM SYSTEM OVERVIEW

This heavy duty Crawler™ Coilover system replaces all eight link arms with extended length units for aggressive offroad use while providing superior on road driving characteristics. The links are mounted up high on the frame for maximum ground clearance.

The large link arms pivot on Fabtech 5 Ton Joints™ for reliability and a quiet ride with a lifetime warranty.

System includes 1/4" thick steel Track Bar brackets that weld on. It's the strongest way to relocate the Track Bars for proper roll center front and rear that will not fail and leave you stranded.

- Provides 12" of articulation and travel without interference to under vehicle components
- Fabtech 5 Ton Joints™ with lifetime warranty
- Proper link arm angle geometry provides excellent on road drive ability
- Lower link arms constructed of 2" OD .313 thick wall tubing guaranteed not to bend
- Proper roll center front and rear with 1/4" thick steel Track Bar brackets

CRAWLER™

COILOVER

FRONT COILOVER CONVERSION

The bolt on front Dirt Logic 2.5 Coilover conversion provides outstanding high speed damping with the ability to crawl at low speed with maximum articulation for big rocks. Coilover is mounted on top of the centerline of the axle to prevent premature Link Arm bushing wear leading to poor handling.

MORE TECH
SEE PAGE **13**



DUAL RATE LONG TRAVEL COIL SPRINGS

Dual rate coil springs provide factory load carrying capacity with a smooth ride. The flexible coil design offers an extended travel range for aggressive rock crawling with great highway manners on 3" & 5" systems.

MORE TECH
SEE PAGE **14**

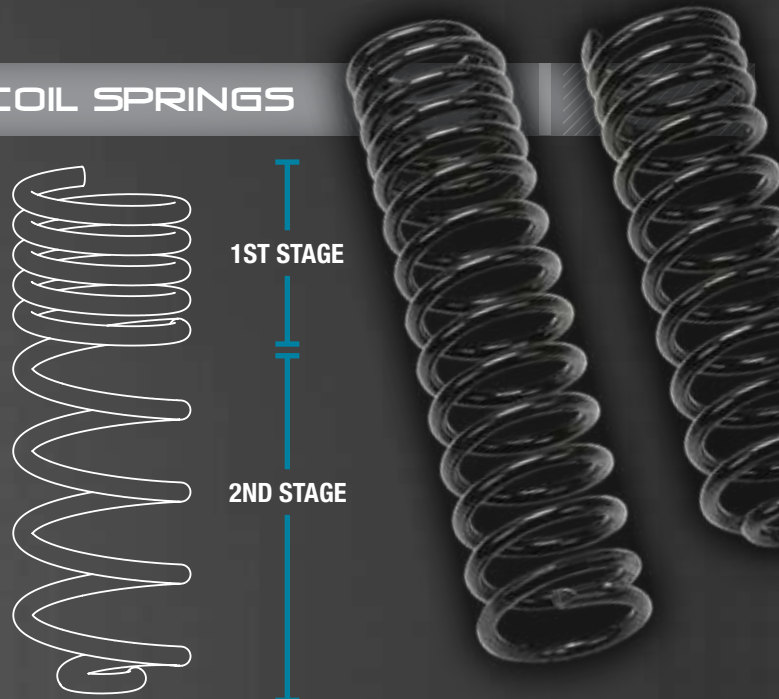

3" CRAWLER™ COILOVER



CRAWLER™ COILOVER SYSTEM

FRONT DIRT LOGIC 2.5 COILOVER RESI SHOCKS

REAR LONG TRAVEL COIL SPRINGS - DIRT LOGIC 2.25 RESI SHOCKS

3" CRAWLER™ COILOVER SYSTEMS

W/ STOCK FENDERS

USE 35/12.50R17 TIRE W/ 17X9 WHEELS W/ 4.5" BS W/ MINOR TRIMMING
 USE 35/12.50R18 TIRE W/ 18X9 WHEELS W/ 4.5" BS W/ MINOR TRIMMING
 USE 325/65R18 TIRE W/ 18X9 WHEELS W/ 4.5" BS W/ MINOR TRIMMING
 USE 35/12.50R20 TIRE W/ 20X9 WHEELS W/ 5" BS W/ MINOR TRIMMING
 USE 325/60R20 TIRE W/ 20X9 WHEELS W/ 5" BS W/ MINOR TRIMMING

2-DOOR MODELS

K4063DL - W/ DIRT LOGIC NON RESI SHOCKS

(50)(120)(151)(152)

1 FTS24185 COILOVER HOOP KIT
 1 FTS24137 FRONT DIRT LOGIC 2.5 COILOVER W/RESI
 1 FTS24165 REAR LONG TRAVEL COILS
 1 FTS24132 FRONT LONG ARM KIT
 1 FTS24134 REAR LONG ARM KIT
 1 FTS24138 LONG TRAVEL COILOVER BOX KIT
 2 FTS811092 REAR DIRT LOGIC 2.25 NON RESI

K4064DL - W/ DIRT LOGIC RESI SHOCKS

(50)(120)(151)(152)

1 FTS24185 COILOVER HOOP KIT
 1 FTS24137 FRONT DIRT LOGIC 2.5 COILOVER W/RESI
 1 FTS24165 REAR LONG TRAVEL COILS
 1 FTS24132 FRONT LONG ARM KIT
 1 FTS24134 REAR LONG ARM KIT
 1 FTS24138 LONG TRAVEL COILOVER BOX KIT
 2 FTS801092 REAR DIRT LOGIC 2.25 W/RESI

W/ TUBE FENDERS

USE 37/12.50R17 TIRE W/ 17X9 WHEELS W/ 4.5" BS W/ CUTTING
 USE 37/12.50R18 TIRE W/ 18X9 WHEELS W/ 4.5" BS W/ CUTTING
 USE 37/12.50R20 TIRE W/ 20X9 WHEELS W/ 5" BS W/ CUTTING

4-DOOR MODELS

K4065DL - W/ DIRT LOGIC NON RESI SHOCKS

(50)(120)(153)(154)

1 FTS24185 COILOVER HOOP KIT
 1 FTS24137 FRONT DIRT LOGIC 2.5 COILOVER W/RESI
 1 FTS24166 REAR LONG TRAVEL COILS
 1 FTS24132 FRONT LONG ARM KIT
 1 FTS24134 REAR LONG ARM KIT
 1 FTS24138 LONG TRAVEL COILOVER BOX KIT
 2 FTS811092 REAR DIRT LOGIC 2.25 NON RESI

K4066DL - W/ DIRT LOGIC RESI SHOCKS

(50)(120)(153)(154)

1 FTS24185 COILOVER HOOP KIT
 1 FTS24137 FRONT DIRT LOGIC 2.5 COILOVER W/RESI
 1 FTS24166 REAR LONG TRAVEL COILS
 1 FTS24132 FRONT LONG ARM KIT
 1 FTS24134 REAR LONG ARM KIT
 1 FTS24138 LONG TRAVEL COILOVER BOX KIT
 2 FTS801092 REAR DIRT LOGIC 2.25 W/RESI

CRAWLER™

COILOVER

5 INCH

3"/ 5" CRAWLER™ COILOVER SYSTEMS INCLUDE

- 8 Long Arm Links & Mounts
- Coilover Hoop Kit Front
- Long Travel Rear Coil Springs
- Track Bar Brackets Front & Rear
- Sway Bar Links Front & Rear
- Pitman Arm
- Brake Lines Front & Rear
- E Brake Bracket
- Rear Bump Stop Brackets
- Front Dirt Logic 2.5 Coilover w/ Resi
- Rear Dirt Logic 2.25 Shocks w/ Resi

5" CRAWLER™ COILOVER SYSTEMS

W/ STOCK FENDERS

USE 37/12.50R17 TIRE W/ 17X9 WHEELS W/ 4.5" BS W/ MINOR TRIMMING
 USE 37/12.50R18 TIRE W/ 18X9 WHEELS W/ 4.5" BS W/ MINOR TRIMMING
 USE 37/12.50R20 TIRE W/ 20X9 WHEELS W/ 5" BS W/ MINOR TRIMMING

W/ TUBE FENDERS

USE 37/12.50R17 TIRE W/ 17X9 WHEELS W/ 4.5" BS W/ NO TRIMMING
 USE 40/13.50R17 TIRE W/ 17X9 WHEELS W/ 4.5" BS W/ CUTTING

2-DOOR MODELS

K4076DL - W/ DIRT LOGIC NON RESI SHOCKS (50)(120)(151)(152)

- 1 FTS24136 COILOVER HOOP KIT
- 1 FTS24106 FRONT DIRT LOGIC 2.5 COILOVER W/RESI
- 1 FTS24145 REAR LONG TRAVEL COILS
- 1 FTS24132 FRONT LONG ARM KIT
- 1 FTS24134 REAR LONG ARM KIT
- 1 FTS24138 LONG TRAVEL COILOVER BOX KIT
- 2 FTS811102 REAR DIRT LOGIC 2.25 NON RESI

K4077DL - W/ DIRT LOGIC RESI SHOCKS (50)(120)(151)(152)

- 1 FTS24136 COILOVER HOOP KIT
- 1 FTS24106 FRONT DIRT LOGIC 2.5 COILOVER W/RESI
- 1 FTS24145 REAR LONG TRAVEL COILS
- 1 FTS24132 FRONT LONG ARM KIT
- 1 FTS24134 REAR LONG ARM KIT
- 1 FTS24138 LONG TRAVEL COILOVER BOX KIT
- 2 FTS801102 REAR DIRT LOGIC 2.25 W/RESI

4-DOOR MODELS

K4078DL - W/ DIRT LOGIC NON RESI SHOCKS (50)(120)(153)(154)

- 1 FTS24136 COILOVER HOOP KIT
- 1 FTS24106 FRONT DIRT LOGIC 2.5 COILOVER W/RESI
- 1 FTS24146 REAR LONG TRAVEL COILS
- 1 FTS24132 FRONT LONG ARM KIT
- 1 FTS24134 REAR LONG ARM KIT
- 1 FTS24138 LONG TRAVEL COILOVER BOX KIT
- 2 FTS811102 REAR DIRT LOGIC 2.25 NON RESI

K4079DL - W/ DIRT LOGIC RESI SHOCKS (50)(120)(153)(154)

- 1 FTS24136 COILOVER HOOP KIT
- 1 FTS24106 FRONT DIRT LOGIC 2.5 COILOVER W/RESI
- 1 FTS24146 REAR LONG TRAVEL COILS
- 1 FTS24132 FRONT LONG ARM KIT
- 1 FTS24134 REAR LONG ARM KIT
- 1 FTS24138 LONG TRAVEL COILOVER BOX KIT
- 2 FTS801102 REAR DIRT LOGIC 2.25 W/RESI

FOOTNOTES: 50. INSTALLATION REQUIRES WELDING.

120. EXHAUST MODIFICATION REQUIRED ON ALL 2012-16 JEEP WRANGLERS OR ORDER LOOP DELETE PIPE (FTS94060).

151. REQUIRES DRIVESHAFTS 2 DOOR MODEL 07-11 FRONT (FTS94057) REAR (FTS94051).

152. REQUIRES DRIVESHAFTS 2 DOOR MODEL 12-16 FRONT (FTS94057) REAR (FTS94058).

153. REQUIRES DRIVESHAFTS 4 DOOR MODELS 07-11 FRONT (FTS94057) REAR (FTS94052).

154. REQUIRES DRIVESHAFTS 4 DOOR MODEL 12-16 FRONT (FTS94057) REAR (FTS94059).



5" CRAWLER™ COILOVER II SYSTEM

39/13.50R17 TIRE W/ 17X9 WHEELS W/ 4.5" BS

CRAWLER™ COILOVER II LONG ARM SYSTEM OVERVIEW

Fabtech's Crawler™ Coilover II system provides unsurpassed articulation for offroad use with great highway manners for the daily driver. The system replaces all eight of the link arms with extended length thick wall tubular links. They are mounted up high on the frame with a 1/4" thick steel crossmember and bracketry for maximum ground clearance.

Link arms pivot on Fabtech's exclusive 5 Ton Joints™, a proven design for over 15 years that comes with a lifetime warranty. The show quality forged steel housing contains a proprietary spherical bearing that will never wear out or make noise on the highway. Guaranteed.

System includes 1/4" thick steel Track Bar brackets that weld on. It's the strongest way to relocate the Track Bars for proper roll center front and rear that will not fail and leave you stranded.

- Provides maximum articulation and travel without interference to under vehicle components
- Fabtech 5 Ton Joints™ with lifetime warranty
- Proper link arm angle geometry provides excellent on road drive ability
- High ground clearance with straight link arms for ultimate strength
- Lower links constructed of 2" OD .313 Thick wall tubing guaranteed not to bend
- 1/4" thick steel Track Bar brackets for proper roll center front & rear



MORE TECH
SEE PAGE **6**

CRAWLER™

COILOVER II



COILOVER CONVERSION

The front and rear Dirt Logic 2.5 Coilover conversion provides outstanding high speed damping with the ability to crawl at low speed with maximum articulation for big rocks.

The front Coilover is mounted on top of the centerline of the axle to prevent premature Link Arm bushing wear leading to poor handling. The rear system features a large one piece sub frame that strengthens the factory frame specifically for coilover use.

- Front Coilover positioned at centerline of axle to prevent premature bushing wear and poor handling
- Designed for full articulation and lock to lock turning radius
- Rear system sub frame strengthens frame for longevity
- Allows for 12" of wheel travel & articulation with 3" and 5" systems

MORE TECH
SEE PAGE **12**

OPTIONS

- Dirt Logic 2.25 Bump Stops for increased damping at full compression - See page 48
- Rear heavy capacity coil springs for additional cargo and trailer towing - See page 46

3" CRAWLER™

INCH. COILOVER II



3" CRAWLER™ COILOVER II SYSTEMS

W/ STOCK FENDERS

USE 35/12.50R17 TIRE W/ 17X9 WHEELS W/ 4.5" BS W/ MINOR TRIMMING
USE 35/12.50R18 TIRE W/ 18X9 WHEELS W/ 4.5" BS W/ MINOR TRIMMING
USE 325/65R18 TIRE W/ 18X9 WHEELS W/ 4.5" BS W/ MINOR TRIMMING
USE 35/12.50R20 TIRE W/ 20X9 WHEELS W/ 5" BS W/ MINOR TRIMMING
USE 325/60R20 TIRE W/ 20X9 WHEELS W/ 5" BS W/ MINOR TRIMMING

W/ TUBE FENDERS

USE 37/12.50R17 TIRE W/ 17X9 WHEELS W/ 4.5" BS W/ CUTTING
USE 37/12.50R18 TIRE W/ 18X9 WHEELS W/ 4.5" BS W/ CUTTING
USE 37/12.50R20 TIRE W/ 20X9 WHEELS W/ 5" BS W/ CUTTING

2 & 4-DOOR MODELS

K4067DL - W/ DIRT LOGIC RESI SHOCKS

(50)(120)(151)(152)(153)(154)(160)

- 1 FTS24132 FRONT LONG ARM KIT
- 1 FTS24185 COILOVER HOOP KIT
- 1 FTS24138 LONG TRAVEL COILOVER BOX KIT
- 1 FTS24134 REAR LONG ARM KIT
- 1 FTS24109 REAR COILOVER CONVERSION
- 1 FTS24137 FRONT DIRT LOGIC 2.5 COILOVER W/RESI
- 1 FTS24153 REAR DIRT LOGIC 2.5 COILOVER W/RESI

CRAWLER™

COILOVER II

5 INCH

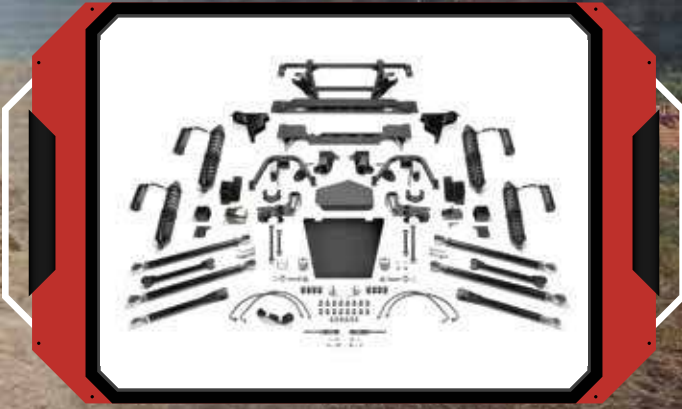

3"/ 5" CRAWLER™ COILOVER II SYSTEMS INCLUDE

- 8 Long Arm Links & Mounts
- Coilover Hoop Kit Front
- Coilover Sub Frame Kit Rear
- Track Bar Brackets Front & Rear
- Sway Bar Links Front & Rear
- Pitman Arm
- Brake Lines Front & Rear
- E Brake Bracket
- Front & Rear Dirt Logic 2.5 Coilover w/ Resi

CRAWLER™ COILOVER II

FRONT & REAR DIRT LOGIC 2.5 COILOVER RESI SHOCKS

5" CRAWLER™ COILOVER II SYSTEMS

W/ STOCK FENDERS

USE 37/12.50R17 TIRE W/ 17X9 WHEELS W/ 4.5" BS W/ MINOR TRIMMING
 USE 37/12.50R18 TIRE W/ 18X9 WHEELS W/ 4.5" BS W/ MINOR TRIMMING
 USE 37/12.50R20 TIRE W/ 20X9 WHEELS W/ 5" BS W/ MINOR TRIMMING

W/ TUBE FENDERS

USE 37/12.50R17 TIRE W/ 17X9 WHEELS W/ 4.5" BS W/ NO TRIMMING
 USE 40/13.50R17 TIRE W/ 17X9 WHEELS W/ 4.5" BS W/ CUTTING

2 & 4-DOOR MODELS

K4080DL - W/ DIRT LOGIC RESI SHOCKS

(50)(120)(151)(152)(153)(154)(160)

- | | | |
|---|----------|--------------------------------------|
| 1 | FTS24132 | FRONT LONG ARM KIT |
| 1 | FTS24136 | COILOVER HOOP KIT |
| 1 | FTS24138 | LONG TRAVEL COILOVER BOX KIT |
| 1 | FTS24134 | REAR LONG ARM KIT |
| 1 | FTS24109 | REAR COIL OVER CONVERSION |
| 1 | FTS24106 | FRONT DIRT LOGIC 2.5 COILOVER W/RESI |
| 1 | FTS24127 | REAR DIRT LOGIC 2.5 COILOVER W/RESI |

- FOOTNOTES:** 50. INSTALLATION REQUIRES WELDING.
 120. EXHAUST MODIFICATION REQUIRED ON ALL 2012-16 JEEP WRANGLERS OR ORDER LOOP DELETE PIPE (FTS94060).
 151. REQUIRES DRIVESHAFTS 2 DOOR MODEL 07-11 FRONT (FTS94057) REAR (FTS94051).
 152. REQUIRES DRIVESHAFTS 2 DOOR MODEL 12-16 FRONT (FTS94057) REAR (FTS94058).
 153. REQUIRES DRIVESHAFTS 4 DOOR MODELS 07-11 FRONT (FTS94057) REAR (FTS94052).
 154. REQUIRES DRIVESHAFTS 4 DOOR MODEL 12-16 FRONT (FTS94057) REAR (FTS94059).
 160. REQUIRES MAGNAFLOW EXHAUST. 2 DOOR PN 15236. 4 DOOR PN 15237.



CRAWLER™ LONG ARM COIL SYSTEM OVERVIEW

Fabtech's Crawler™ long arm coil systems replace all eight of the link arms with extended length units to allow for smooth operation at extreme angles. The link arms are mounted up high on the frame to increase ground clearance without the need to bend the Links as with other long arm systems on the market.

Construction of the link arms is nothing short of the best heavy duty units you can buy. Each lower link is built from 2" OD .313 thick wall DOM that is so strong Fabtech provides a warranty against bending.

Link arms are internally threaded to accept the ground breaking Fabtech 5 Ton Joint™ that is guaranteed never to wear out.

Weld on 1/4" thick steel Track Bar brackets provide the proper roll center front and rear and will not fail leaving you stranded.

- Long Travel or Standard coil springs option
- Provides 12" articulation and travel without interference to under vehicle components
- Fabtech 5 Ton Joints™ with lifetime warranty
- High ground clearance position with straight Link Arms for ultimate strength
- Lower links constructed of 2" OD .313 Thick wall tubing guaranteed not to bend
- 1/4" thick steel Track Bar brackets for proper roll center front & rear

MORE TECH
SEE PAGE **6**

CRAWLER™

COIL SPRINGS



3" CRAWLER™ LONG TRAVEL SYSTEM - DIRT LOGIC RESI SHOCKS
35/12.50R17 TIRE W/ 17X9 WHEELS W/ 4.5" BS

CRAWLER™ LONG TRAVEL SYSTEMS

System includes dual rate Long Travel coil springs that provide factory load carrying capacity with a smooth ride. The flexible coil design offers an extended travel range for aggressive rock crawling with great highway manners.

MORE TECH
SEE PAGE **14**



1ST STAGE

2ND STAGE



CRAWLER™ SYSTEMS

This system utilizes Fabtech's Standard coil springs that are a single rate design and provide great all around suspension performance. Factory load carrying capacities are retained in these quality springs.

MORE TECH
SEE PAGE **15**

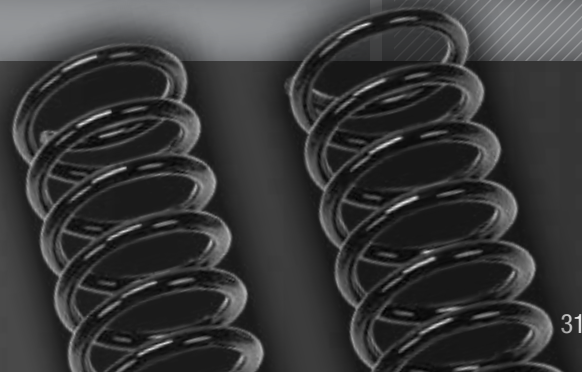

3" CRAWLER™

INCH. STANDARD SPRINGS

3" CRAWLER™ SYSTEMS INCLUDE

- 8 Long Arm Links & Mounts
- Standard Travel Coil Springs Front & Rear
- Sway Bar Links Front & Rear
- Adjustable Track Bar Front
- Track Bar Bracket Rear
- Brake Lines Front & Rear
- E Brake Bracket
- Bump Stop Extensions Front
- Bump Stop Brackets Rear
- Available with Dirt Logic 2.25 or Stealth shocks

3" CRAWLER™ SYSTEMS

W/ STOCK FENDERS

USE 35/12.50R17 TIRE W/ 17X9 WHEELS W/ 4.5" BS W/ MINOR TRIMMING
 USE 35/12.50R18 TIRE W/ 18X9 WHEELS W/ 4.5" BS W/ MINOR TRIMMING
 USE 325/65R18 TIRE W/ 18X9 WHEELS W/ 4.5" BS W/ MINOR TRIMMING
 USE 35/12.50R20 TIRE W/ 20X9 WHEELS W/ 5" BS W/ MINOR TRIMMING
 USE 325/60R20 TIRE W/ 20X9 WHEELS W/ 5" BS W/ MINOR TRIMMING

W/ TUBE FENDERS

USE 37/12.50R17 TIRE W/ 17X9 WHEELS W/ 4.5" BS W/ CUTTING
 USE 37/12.50R18 TIRE W/ 18X9 WHEELS W/ 4.5" BS W/ CUTTING
 USE 37/12.50R20 TIRE W/ 20X9 WHEELS W/ 5" BS W/ CUTTING

2-DOOR MODELS

K4057M - W/ STEALTH SHOCKS

(50)(120)(151)(152)

1 FTS24161 FRONT & REAR STANDARD COILS
 1 FTS24132 FRONT LONG ARM KIT
 1 FTS24134 REAR LONG ARM KIT
 1 FTS24129 1.75"-5" CHROMOLY FRONT TRACK BAR
 1 FTS24135 STANDARD BOX KIT
 2 FTS6021 FRONT STEALTH MONOTUBE
 2 FTS6265 REAR STEALTH MONOTUBE

K4057DL - W/ DIRT LOGIC NON RESI SHOCKS

(50)(120)(151)(152)

1 FTS24161 FRONT & REAR STANDARD COILS
 1 FTS24132 FRONT LONG ARM KIT
 1 FTS24134 REAR LONG ARM KIT
 1 FTS24129 1.75"-5" CHROMOLY FRONT TRACK BAR
 1 FTS24135 STANDARD BOX KIT
 2 FTS810582 FRONT DIRT LOGIC 2.25 NON RESI
 2 FTS811092 REAR DIRT LOGIC 2.25 NON RESI

4-DOOR MODELS

K4058M - W/ STEALTH SHOCKS

(50)(120)(153)(154)

1 FTS24162 FRONT & REAR STANDARD COILS
 1 FTS24132 FRONT LONG ARM KIT
 1 FTS24134 REAR LONG ARM KIT
 1 FTS24129 1.75"-5" CHROMOLY FRONT TRACK BAR
 1 FTS24135 STANDARD BOX KIT
 2 FTS6021 FRONT STEALTH MONOTUBE
 2 FTS6265 REAR STEALTH MONOTUBE

K4058DL - W/ DIRT LOGIC NON RESI SHOCKS

(50)(120)(153)(154)

1 FTS24162 FRONT & REAR STANDARD COILS
 1 FTS24132 FRONT LONG ARM KIT
 1 FTS24134 REAR LONG ARM KIT
 1 FTS24129 1.75"-5" CHROMOLY FRONT TRACK BAR
 1 FTS24135 STANDARD BOX KIT
 2 FTS810582 FRONT DIRT LOGIC 2.25 NON RESI
 2 FTS811092 REAR DIRT LOGIC 2.25 NON RESI

FOOTNOTES: 50. INSTALLATION REQUIRES WELDING.

120. EXHAUST MODIFICATION REQUIRED ON ALL 2012-16 JEEP WRANGLERS OR ORDER LOOP DELETE PIPE (FTS94060).

151. REQUIRES DRIVESHAFTS 2 DOOR MODEL 07-11 FRONT (FTS94057) REAR (FTS94051).

152. REQUIRES DRIVESHAFTS 2 DOOR MODEL 12-16 FRONT (FTS94057) REAR (FTS94058).

153. REQUIRES DRIVESHAFTS 4 DOOR MODELS 07-11 FRONT (FTS94057) REAR (FTS94052).

154. REQUIRES DRIVESHAFTS 4 DOOR MODEL 12-16 FRONT (FTS94057) REAR (FTS94059).



CRAWLER™ SYSTEM

STANDARD COIL SPRINGS - DIRT LOGIC SHOCKS



3 CRAWLER™

INCH. LONG TRAVEL SPRINGS

3"/ 5" CRAWLER™ LONG TRAVEL SYSTEMS INCLUDE

- 8 Long Arm Links & Mounts
- Long Travel Coil Springs Front & Rear
- Sway Bar Links Front & Rear
- Lower Long Travel Shock Brackets Front
- Track Bar Brackets Front & Rear
- Pitman Arm
- Brake Lines Front & Rear
- E Brake Bracket
- Bump Stop Extensions Front
- Bump Stop Brackets Rear
- Available with Dirt Logic 2.25 or Stealth shocks



CRAWLER™ LONG TRAVEL SYSTEM
LONG TRAVEL COIL SPRINGS - STEALTH SHOCKS

3" CRAWLER™ LONG TRAVEL SYSTEMS

W/ STOCK FENDERS

- USE 35/12.50R17 TIRE W/ 17X9 WHEELS W/ 4.5" BS W/ MINOR TRIMMING
- USE 35/12.50R18 TIRE W/ 18X9 WHEELS W/ 4.5" BS W/ MINOR TRIMMING
- USE 325/65R18 TIRE W/ 18X9 WHEELS W/ 4.5" BS W/ MINOR TRIMMING
- USE 35/12.50R20 TIRE W/ 20X9 WHEELS W/ 5" BS W/ MINOR TRIMMING
- USE 325/60R20 TIRE W/ 20X9 WHEELS W/ 5" BS W/ MINOR TRIMMING

W/ TUBE FENDERS

- USE 37/12.50R17 TIRE W/ 17X9 WHEELS W/ 4.5" BS W/ CUTTING
- USE 37/12.50R18 TIRE W/ 18X9 WHEELS W/ 4.5" BS W/ CUTTING
- USE 37/12.50R20 TIRE W/ 20X9 WHEELS W/ 5" BS W/ CUTTING

2-DOOR MODELS

K4059M - W/ STEALTH SHOCKS

(50)(120)(151)(152)

- 1 FTS24163 FRONT & REAR LONG TRAVEL COILS
- 1 FTS24132 FRONT LONG ARM KIT
- 1 FTS24134 REAR LONG ARM KIT
- 1 FTS24131 LONG TRAVEL BOX KIT
- 2 FTS6016 FRONT STEALTH MONOTUBE
- 2 FTS6265 REAR STEALTH MONOTUBE

K4059DL - W/ DIRT LOGIC NON RESI SHOCKS

(50)(120)(151)(152)

- 1 FTS24163 FRONT & REAR LONG TRAVEL COILS
- 1 FTS24132 FRONT LONG ARM KIT
- 1 FTS24134 REAR LONG ARM KIT
- 1 FTS24131 LONG TRAVEL BOX KIT
- 2 FTS811182 FRONT DIRT LOGIC 2.25 NON RESI
- 2 FTS811092 REAR DIRT LOGIC 2.25 NON RESI

K4060DL - W/ DIRT LOGIC RESI SHOCKS

(50)(120)(151)(152)

- 1 FTS24163 FRONT & REAR LONG TRAVEL COILS
- 1 FTS24132 FRONT LONG ARM KIT
- 1 FTS24134 REAR LONG ARM KIT
- 1 FTS24131 LONG TRAVEL BOX KIT
- 2 FTS801182 FRONT DIRT LOGIC 2.25 W/RESI
- 2 FTS801092 REAR DIRT LOGIC 2.25 W/RESI

4-DOOR MODELS

K4061M - W/ STEALTH SHOCKS

(50)(120)(153)(154)

- 1 FTS24164 FRONT & REAR LONG TRAVEL COILS
- 1 FTS24132 FRONT LONG ARM KIT
- 1 FTS24134 REAR LONG ARM KIT
- 1 FTS24131 LONG TRAVEL BOX KIT
- 2 FTS6016 FRONT STEALTH MONOTUBE
- 2 FTS6265 REAR STEALTH MONOTUBE

K4061DL - W/ DIRT LOGIC NON RESI SHOCKS

(50)(120)(153)(154)

- 1 FTS24164 FRONT & REAR LONG TRAVEL COILS
- 1 FTS24132 FRONT LONG ARM KIT
- 1 FTS24134 REAR LONG ARM KIT
- 1 FTS24131 LONG TRAVEL BOX KIT
- 2 FTS811182 FRONT DIRT LOGIC 2.25 NON RESI
- 2 FTS811092 REAR DIRT LOGIC 2.25 NON RESI

K4062DL - W/ DIRT LOGIC RESI SHOCKS

(50)(120)(153)(154)

- 1 FTS24164 FRONT & REAR LONG TRAVEL COILS
- 1 FTS24132 FRONT LONG ARM KIT
- 1 FTS24134 REAR LONG ARM KIT
- 1 FTS24131 LONG TRAVEL BOX KIT
- 2 FTS801182 FRONT DIRT LOGIC 2.25 W/RESI
- 2 FTS801092 REAR DIRT LOGIC 2.25 W/RESI

CRAWLER[™] 5 INCH

LONG TRAVEL SPRINGS

5" CRAWLER[™] LONG TRAVEL SYSTEMS

W/ STOCK FENDERS

USE 37/12.50R17 TIRE W/ 17X9 WHEELS W/ 4.5" BS W/ MINOR TRIMMING
 USE 37/12.50R18 TIRE W/ 18X9 WHEELS W/ 4.5" BS W/ MINOR TRIMMING
 USE 37/12.50R20 TIRE W/ 20X9 WHEELS W/ 5" BS W/ MINOR TRIMMING

W/ TUBE FENDERS

USE 37/12.50R17 TIRE W/ 17X9 WHEELS W/ 4.5" BS W/ NO TRIMMING
 USE 40/13.50R17 TIRE W/ 17X9 WHEELS W/ 4.5" BS W/ CUTTING

2-DOOR MODELS

K4072M - W/ STEALTH SHOCKS

(50)(120)(151)(152)

1 FTS24143 FRONT & REAR LONG TRAVEL COILS
 1 FTS24132 FRONT LONG ARM KIT
 1 FTS24134 REAR LONG ARM KIT
 1 FTS24131 LONG TRAVEL BOX KIT
 2 FTS6016 FRONT STEALTH MONOTUBE
 2 FTS6349 REAR STEALTH MONOTUBE

4-DOOR MODELS

K4074M - W/ STEALTH SHOCKS

(50)(120)(153)(154)

1 FTS24154 FRONT & REAR LONG TRAVEL COILS
 1 FTS24132 FRONT LONG ARM KIT
 1 FTS24134 REAR LONG ARM KIT
 1 FTS24131 LONG TRAVEL BOX KIT
 2 FTS6016 FRONT STEALTH MONOTUBE
 2 FTS6349 REAR STEALTH MONOTUBE

K4072DL - W/ DIRT LOGIC NON RESI SHOCKS

(50)(120)(151)(152)

1 FTS24143 FRONT & REAR LONG TRAVEL COILS
 1 FTS24132 FRONT LONG ARM KIT
 1 FTS24134 REAR LONG ARM KIT
 1 FTS24131 LONG TRAVEL BOX KIT
 2 FTS810222 FRONT DIRT LOGIC 2.25 NON RESI
 2 FTS811102 REAR DIRT LOGIC 2.25 NON RESI

K4074DL - W/ DIRT LOGIC NON RESI SHOCKS

(50)(120)(153)(154)

1 FTS24154 FRONT & REAR LONG TRAVEL COILS
 1 FTS24132 FRONT LONG ARM KIT
 1 FTS24134 REAR LONG ARM KIT
 1 FTS24131 LONG TRAVEL BOX KIT
 2 FTS810222 FRONT DIRT LOGIC 2.25 NON RESI
 2 FTS811102 REAR DIRT LOGIC 2.25 NON RESI

K4073DL - W/ DIRT LOGIC RESI SHOCKS

(50)(120)(151)(152)

1 FTS24143 FRONT & REAR LONG TRAVEL COILS
 1 FTS24132 FRONT LONG ARM KIT
 1 FTS24134 REAR LONG ARM KIT
 1 FTS24131 LONG TRAVEL BOX KIT
 2 FTS800222 FRONT DIRT LOGIC 2.25 W/RESI
 2 FTS801102 REAR DIRT LOGIC 2.25 W/RESI

K4075DL - W/ DIRT LOGIC RESI SHOCKS

(50)(120)(153)(154)

1 FTS24154 FRONT & REAR LONG TRAVEL COILS
 1 FTS24132 FRONT LONG ARM KIT
 1 FTS24134 REAR LONG ARM KIT
 1 FTS24131 LONG TRAVEL BOX KIT
 2 FTS800222 FRONT DIRT LOGIC 2.25 W/RESI
 2 FTS801102 REAR DIRT LOGIC 2.25 W/RESI

FOOTNOTES: 50. INSTALLATION REQUIRES WELDING.

120. EXHAUST MODIFICATION REQUIRED ON ALL 2012-16 JEEP WRANGLERS OR ORDER LOOP DELETE PIPE (FTS94060).

151. REQUIRES DRIVESHAFTS 2 DOOR MODEL 07-11 FRONT (FTS94057) REAR (FTS94051).

152. REQUIRES DRIVESHAFTS 2 DOOR MODEL 12-16 FRONT (FTS94057) REAR (FTS94058).

153. REQUIRES DRIVESHAFTS 4 DOOR MODELS 07-11 FRONT (FTS94057) REAR (FTS94052).

154. REQUIRES DRIVESHAFTS 4 DOOR MODEL 12-16 FRONT (FTS94057) REAR (FTS94059).

TRAIL SHORT ARM SYSTEM OVERVIEW

Utilizing the factory link arm mounts Fabtech's Trail short arm suspensions are built for aggressive offroad use while providing a smooth and quiet highway ride. Each system has features and benefits that address all variants of off highway travel use including rock crawling, aggressive trail use and overland expeditions.

The Trail system replaces the four lower link arms due to their vulnerability to offroad obstacles. Link arms come with large poly urethane bushings on one end with internal threads on the other to accept the ground breaking Fabtech 5 Ton Joint™ for longevity and a quiet ride.

- Long Travel or Standard coil springs option
- Properly designed link arms reduce bushing wear while providing maximum articulation and travel without interference to under vehicle components
- Massive Fabtech 5 Ton Joint™ with lifetime warranty
- 1.75" OD .250 thick wall Link Arms guaranteed not to bend
- Excellent drive ability both on and offroad

MORE TECH
SEE PAGE 10

TRAIL SHORT ARM LINK DESIGN

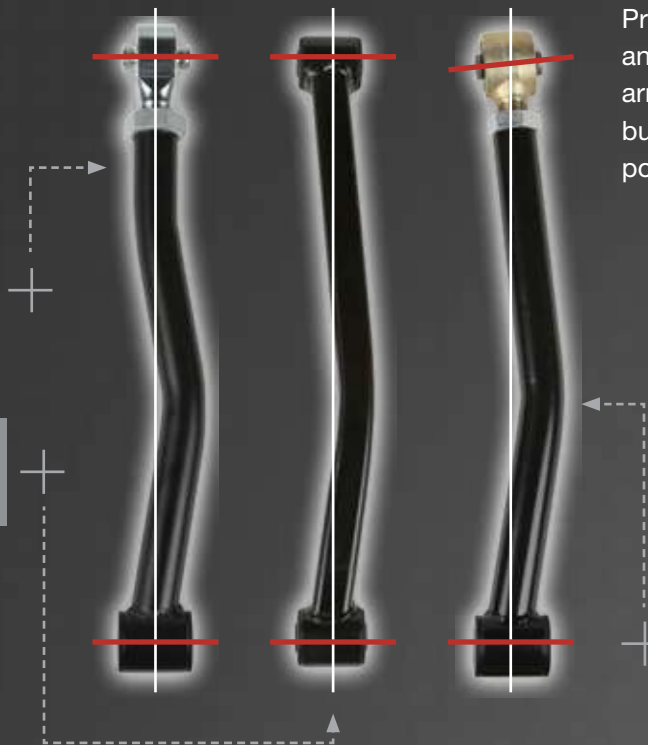

FABTECH
Correct parallel joint angles with double bend link for tire clearance

FACTORY
Correct parallel joint angles

Proper factory pivot cross bolt angle are parallel on Fabtech short arm links eliminating premature bushing wear resulting in poor handling.

MORE TECH
SEE PAGE 11

OTHERS INCORRECT LINK DESIGN
Joint angles not parallel

5 TON JOINT™



Ultra heavy duty Link Arm joints that are quiet and come with a lifetime warranty against wearing out. Guaranteed.

MORE TECH
SEE PAGE 11

TRAIL

COIL SPRINGS



TRAIL LONG TRAVEL SYSTEMS

System includes dual rate Long Travel coil springs that provide factory load carrying capacity with a smooth ride. The flexible coil design offers an extended travel range for aggressive rock crawling with great highway manners.

MORE TECH
SEE PAGE **14**



1ST STAGE

2ND STAGE

TRAIL & TRAIL II SYSTEMS

These systems utilize Fabtech's Standard coil springs that are a single rate design and provide great all around suspension performance. Factory load carrying capacities are retained in these quality springs.

MORE TECH
SEE PAGE **15**



3" TRAIL STANDARD SPRINGS



3" TRAIL SYSTEMS INCLUDE

- Lower Short Arm Links Front & Rear
- Standard Coil Springs Front & Rear
- Track Bar Brackets Front & Rear
- Sway Bar Links Front
- Pitman Arm
- Brake Line Drop Bracket Rear
- E Brake Bracket
- Bump Stop Extensions Front
- Bump Stop Brackets Rear
- Available with Dirt Logic 2.25, Stealth or Performance shocks
- Optional Upper Links available

TRAIL SYSTEM

STANDARD COIL SPRINGS - DIRT LOGIC NON RESI SHOCKS

3" TRAIL SYSTEMS

W/ STOCK FENDERS

USE 35/12.50R17 TIRE W/ 17X9 WHEELS W/ 4.5" BS W/ MINOR TRIMMING
 USE 35/12.50R18 TIRE W/ 18X9 WHEELS W/ 4.5" BS W/ MINOR TRIMMING
 USE 325/65R18 TIRE W/ 18X9 WHEELS W/ 4.5" BS W/ MINOR TRIMMING
 USE 35/12.50R20 TIRE W/ 20X9 WHEELS W/ 5" BS W/ MINOR TRIMMING
 USE 325/60R20 TIRE W/ 20X9 WHEELS W/ 5" BS W/ MINOR TRIMMING

W/ TUBE FENDERS

USE 37/12.50R17 TIRE W/ 17X9 WHEELS W/ 4.5" BS W/ CUTTING
 USE 37/12.50R18 TIRE W/ 18X9 WHEELS W/ 4.5" BS W/ CUTTING
 USE 37/12.50R20 TIRE W/ 20X9 WHEELS W/ 5" BS W/ CUTTING

2-DOOR MODELS

K4089 - W/ PERFORMANCE SHOCKS

(148)(155)(156)

- 1 FTS24161 FRONT & REAR STANDARD COILS
- 1 FTS24128 FRONT & REAR SHORT ARM LOWER LINKS
- 1 FTS24183 STANDARD BOX KIT
- 2 FTS7236 FRONT PERFORMANCE SHOCK
- 2 FTS7265 REAR PERFORMANCE SHOCK

K4089M - W/ STEALTH SHOCKS

(148)(155)(156)

- 1 FTS24161 FRONT & REAR STANDARD COILS
- 1 FTS24128 FRONT & REAR SHORT ARM LOWER LINKS
- 1 FTS24183 STANDARD BOX KIT
- 2 FTS6021 FRONT STEALTH MONOTUBE
- 2 FTS6265 REAR STEALTH MONOTUBE

K4089DL - W/ DIRT LOGIC NON RESI SHOCKS

(148)(155)(156)

- 1 FTS24161 FRONT & REAR STANDARD COILS
- 1 FTS24128 FRONT & REAR SHORT ARM LOWER LINKS
- 1 FTS24183 STANDARD BOX KIT
- 2 FTS810582 FRONT DIRT LOGIC 2.25 NON RESI
- 2 FTS811092 REAR DIRT LOGIC 2.25 NON RESI

4-DOOR MODELS

K4090 - W/ PERFORMANCE SHOCKS

(148)(157)(158)

- 1 FTS24162 FRONT & REAR STANDARD COILS
- 1 FTS24128 FRONT & REAR SHORT ARM LOWER LINKS
- 1 FTS24183 STANDARD BOX KIT
- 2 FTS7236 FRONT PERFORMANCE SHOCK
- 2 FTS7265 REAR PERFORMANCE SHOCK

K4090M - W/ STEALTH SHOCKS

(148)(157)(158)

- 1 FTS24162 FRONT & REAR STANDARD COILS
- 1 FTS24128 FRONT & REAR SHORT ARM LOWER LINKS
- 1 FTS24183 STANDARD BOX KIT
- 2 FTS6021 FRONT STEALTH MONOTUBE
- 2 FTS6265 REAR STEALTH MONOTUBE

K4090DL - W/ DIRT LOGIC NON RESI SHOCKS

(148)(157)(158)

- 1 FTS24162 FRONT & REAR STANDARD COILS
- 1 FTS24128 FRONT & REAR SHORT ARM LOWER LINKS
- 1 FTS24183 STANDARD BOX KIT
- 2 FTS810582 FRONT DIRT LOGIC 2.25 NON RESI
- 2 FTS811092 REAR DIRT LOGIC 2.25 NON RESI

TRAIL II 3 INCH

STANDARD SPRINGS

3" TRAIL II SYSTEMS INCLUDE

- Lower Short Arm Links Front & Rear
- Standard Coil Springs Front & Rear
- Adjustable Track Bar Front
- Sway Bar Links Front

- Track Bar Bracket w/ Support Rear
- Brake Lines Front & Rear
- E Brake Bracket
- Bump Stop Extensions Front
- Bump Stop Brackets Rear
- Available with Dirt Logic 2.25, Stealth or Performance shocks
- Optional Upper Links available

3" TRAIL II SYSTEMS

W/ STOCK FENDERS

USE 35/12.50R17 TIRE W/ 17X9 WHEELS W/ 4.5" BS W/ MINOR TRIMMING
 USE 35/12.50R18 TIRE W/ 18X9 WHEELS W/ 4.5" BS W/ MINOR TRIMMING
 USE 325/65R18 TIRE W/ 18X9 WHEELS W/ 4.5" BS W/ MINOR TRIMMING
 USE 35/12.50R20 TIRE W/ 20X9 WHEELS W/ 5" BS W/ MINOR TRIMMING
 USE 325/60R20 TIRE W/ 20X9 WHEELS W/ 5" BS W/ MINOR TRIMMING

W/ TUBE FENDERS

USE 37/12.50R17 TIRE W/ 17X9 WHEELS W/ 4.5" BS W/ CUTTING
 USE 37/12.50R18 TIRE W/ 18X9 WHEELS W/ 4.5" BS W/ CUTTING
 USE 37/12.50R20 TIRE W/ 20X9 WHEELS W/ 5" BS W/ CUTTING

2-DOOR MODELS

K4051 - W/ PERFORMANCE SHOCKS

(148)(155)(156)

- | | | |
|---|----------|------------------------------------|
| 1 | FTS24161 | FRONT & REAR STANDARD COILS |
| 1 | FTS24128 | FRONT & REAR SHORT ARM LOWER LINKS |
| 1 | FTS24129 | 1.75"-5" CHROMOLY FRONT TRACK BAR |
| 1 | FTS24130 | STANDARD BOX KIT |
| 2 | FTS7236 | FRONT PERFORMANCE SHOCK |
| 2 | FTS7265 | REAR PERFORMANCE SHOCK |

4-DOOR MODELS

K4052 - W/ PERFORMANCE SHOCKS

(148)(157)(158)

- | | | |
|---|----------|------------------------------------|
| 1 | FTS24162 | FRONT & REAR STANDARD COILS |
| 1 | FTS24128 | FRONT & REAR SHORT ARM LOWER LINKS |
| 1 | FTS24129 | 1.75"-5" CHROMOLY FRONT TRACK BAR |
| 1 | FTS24130 | STANDARD BOX KIT |
| 2 | FTS7236 | FRONT PERFORMANCE SHOCK |
| 2 | FTS7265 | REAR PERFORMANCE SHOCK |

K4051M - W/ STEALTH SHOCKS

(148)(155)(156)

- | | | |
|---|----------|------------------------------------|
| 1 | FTS24161 | FRONT & REAR STANDARD COILS |
| 1 | FTS24128 | FRONT & REAR SHORT ARM LOWER LINKS |
| 1 | FTS24129 | 1.75"-5" CHROMOLY FRONT TRACK BAR |
| 1 | FTS24130 | STANDARD BOX KIT |
| 2 | FTS6021 | FRONT STEALTH MONOTUBE |
| 2 | FTS6265 | REAR STEALTH MONOTUBE |

K4052M - W/ STEALTH SHOCKS

(148)(157)(158)

- | | | |
|---|----------|------------------------------------|
| 1 | FTS24162 | FRONT & REAR STANDARD COILS |
| 1 | FTS24128 | FRONT & REAR SHORT ARM LOWER LINKS |
| 1 | FTS24129 | 1.75"-5" CHROMOLY FRONT TRACK BAR |
| 1 | FTS24130 | STANDARD BOX KIT |
| 2 | FTS6021 | FRONT STEALTH MONOTUBE |
| 2 | FTS6265 | REAR STEALTH MONOTUBE |

K4051DL - W/ DIRT LOGIC NON RESI SHOCKS

(148)(155)(156)

- | | | |
|---|-----------|------------------------------------|
| 1 | FTS24161 | FRONT & REAR STANDARD COILS |
| 1 | FTS24128 | FRONT & REAR SHORT ARM LOWER LINKS |
| 1 | FTS24129 | 1.75"-5" CHROMOLY FRONT TRACK BAR |
| 1 | FTS24130 | STANDARD BOX KIT |
| 2 | FTS810582 | FRONT DIRT LOGIC 2.25 NON RESI |
| 2 | FTS811092 | REAR DIRT LOGIC 2.25 NON RESI |

K4052DL - W/ DIRT LOGIC NON RESI SHOCKS

(148)(157)(158)

- | | | |
|---|-----------|------------------------------------|
| 1 | FTS24162 | FRONT & REAR STANDARD COILS |
| 1 | FTS24128 | FRONT & REAR SHORT ARM LOWER LINKS |
| 1 | FTS24129 | 1.75"-5" CHROMOLY FRONT TRACK BAR |
| 1 | FTS24130 | STANDARD BOX KIT |
| 2 | FTS810582 | FRONT DIRT LOGIC 2.25 NON RESI |
| 2 | FTS811092 | REAR DIRT LOGIC 2.25 NON RESI |

FOOTNOTES: 148. EXHAUST SPACER (FTS24126) REQUIRED ON ALL 2012-16 JEEP WRANGLERS.

155. HEAVY OFFROAD USE REQUIRES DRIVESHAFTS 2 DOOR MODEL 07-11 FRONT (FTS94057) REAR (FTS94051).

156. HEAVY OFFROAD USE REQUIRES DRIVESHAFTS 2 DOOR MODEL 12-16 FRONT (FTS94057) REAR (FTS94058).

157. HEAVY OFFROAD USE REQUIRES DRIVESHAFTS 4 DOOR MODELS 07-11 FRONT (FTS94057) REAR (FTS94052).

158. HEAVY OFFROAD USE REQUIRES DRIVESHAFTS 4 DOOR MODEL 12-16 FRONT (FTS94057) REAR (FTS94059).

3" TRAIL LONG TRAVEL SPRINGS

3" / 5" TRAIL LONG TRAVEL SYSTEMS INCLUDE

- Lower Short Arm Links Front & Rear
- Long Travel Coil Springs Front & Rear
- Lower Long Travel Shock Brackets Front
- Track Bar Brackets Front & Rear
- Sway Bar Links Front & Rear
- Pitman Arm
- Brake Lines Front & Rear
- E Brake Bracket
- Bump Stop Extensions Front
- Bump Stop Brackets Rear
- Available with Dirt Logic 2.25 or Stealth shocks
- Optional Upper Links available

3" TRAIL LONG TRAVEL SYSTEMS

W/ STOCK FENDERS

USE 35/12.50R17 TIRE W/ 17X9 WHEELS W/ 4.5" BS W/ MINOR TRIMMING
USE 35/12.50R18 TIRE W/ 18X9 WHEELS W/ 4.5" BS W/ MINOR TRIMMING
USE 325/65R18 TIRE W/ 18X9 WHEELS W/ 4.5" BS W/ MINOR TRIMMING
USE 35/12.50R20 TIRE W/ 20X9 WHEELS W/ 5" BS W/ MINOR TRIMMING
USE 325/60R20 TIRE W/ 20X9 WHEELS W/ 5" BS W/ MINOR TRIMMING

2-DOOR MODELS

K4053M - W/ STEALTH SHOCKS

(50)(148)(151)(152)

1 FTS24163 FRONT & REAR LONG TRAVEL COILS
1 FTS24128 FRONT & REAR SHORT ARM LOWER LINKS
1 FTS24131 LONG TRAVEL BOX KIT
2 FTS6016 FRONT STEALTH MONOTUBE
2 FTS6265 REAR STEALTH MONOTUBE

K4053DL - W/ DIRT LOGIC NON RESI SHOCKS

(50)(148)(151)(152)

1 FTS24163 FRONT & REAR LONG TRAVEL COILS
1 FTS24128 FRONT & REAR SHORT ARM LOWER LINKS
1 FTS24131 LONG TRAVEL BOX KIT
2 FTS811182 FRONT DIRT LOGIC 2.25 NON RESI
2 FTS811092 REAR DIRT LOGIC 2.25 NON RESI

K4054DL - W/ DIRT LOGIC RESI SHOCKS

(50)(148)(151)(152)

1 FTS24163 FRONT & REAR LONG TRAVEL COILS
1 FTS24128 FRONT & REAR SHORT ARM LOWER LINKS
1 FTS24131 LONG TRAVEL BOX KIT
2 FTS801182 FRONT DIRT LOGIC 2.25 W/RESI
2 FTS801092 REAR DIRT LOGIC 2.25 W/RESI

W/ TUBE FENDERS

USE 37/12.50R17 TIRE W/ 17X9 WHEELS W/ 4.5" BS W/ CUTTING
USE 37/12.50R18 TIRE W/ 18X9 WHEELS W/ 4.5" BS W/ CUTTING
USE 37/12.50R20 TIRE W/ 20X9 WHEELS W/ 5" BS W/ CUTTING

4-DOOR MODELS

K4055M - W/ STEALTH SHOCKS

(50)(148)(153)(154)

1 FTS24164 FRONT & REAR LONG TRAVEL COILS
1 FTS24128 FRONT & REAR SHORT ARM LOWER LINKS
1 FTS24131 LONG TRAVEL BOX KIT
2 FTS6016 FRONT STEALTH MONOTUBE
2 FTS6265 REAR STEALTH MONOTUBE

K4055DL - W/ DIRT LOGIC NON RESI SHOCKS

(50)(148)(153)(154)

1 FTS24164 FRONT & REAR LONG TRAVEL COILS
1 FTS24128 FRONT & REAR SHORT ARM LOWER LINKS
1 FTS24131 LONG TRAVEL BOX KIT
2 FTS811182 FRONT DIRT LOGIC 2.25 NON RESI
2 FTS811092 REAR DIRT LOGIC 2.25 NON RESI

K4056DL - W/ DIRT LOGIC RESI SHOCKS

(50)(148)(153)(154)

1 FTS24164 FRONT & REAR LONG TRAVEL COILS
1 FTS24128 FRONT & REAR SHORT ARM LOWER LINKS
1 FTS24131 LONG TRAVEL BOX KIT
2 FTS801182 FRONT DIRT LOGIC 2.25 W/RESI
2 FTS801092 REAR DIRT LOGIC 2.25 W/RESI

TRAIL 5 INCH

LONG TRAVEL SPRINGS

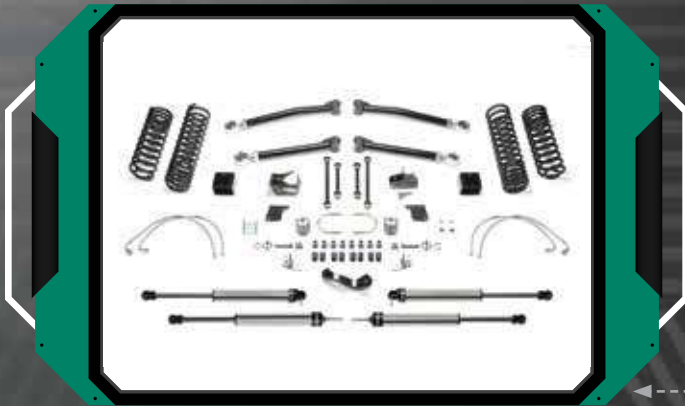

TRAIL LONG TRAVEL SYSTEM

LONG TRAVEL COIL SPRINGS - DIRT LOGIC NON RESI SHOCKS

5" TRAIL LONG TRAVEL SYSTEMS

W/ STOCK FENDERS

USE 37/12.50R17 TIRE W/ 17X9 WHEELS W/ 4.5" BS W/ MINOR TRIMMING
 USE 37/12.50R18 TIRE W/ 18X9 WHEELS W/ 4.5" BS W/ MINOR TRIMMING
 USE 37/12.50R20 TIRE W/ 20X9 WHEELS W/ 5" BS W/ MINOR TRIMMING

2-DOOR MODELS

K4068M - W/ STEALTH SHOCKS

(50)(151)(152)

- 1 FTS24143 FRONT & REAR LONG TRAVEL COILS
- 1 FTS24128 FRONT & REAR SHORT ARM LOWER LINKS
- 1 FTS24131 LONG TRAVEL BOX KIT
- 2 FTS6016 FRONT STEALTH MONOTUBE
- 2 FTS6349 REAR STEALTH MONOTUBE

K4068DL - W/ DIRT LOGIC NON RESI SHOCKS

(50)(151)(152)

- 1 FTS24143 FRONT & REAR LONG TRAVEL COILS
- 1 FTS24128 FRONT & REAR SHORT ARM LOWER LINKS
- 1 FTS24131 LONG TRAVEL BOX KIT
- 2 FTS810222 FRONT DIRT LOGIC 2.25 NON RESI
- 2 FTS811102 REAR DIRT LOGIC 2.25 NON RESI

K4069DL - W/ DIRT LOGIC RESI SHOCKS

(50)(151)(152)

- 1 FTS24143 FRONT & REAR LONG TRAVEL COILS
- 1 FTS24128 FRONT & REAR SHORT ARM LOWER LINKS
- 1 FTS24131 LONG TRAVEL BOX KIT
- 2 FTS800222 FRONT DIRT LOGIC 2.25 W/RESI
- 2 FTS801102 REAR DIRT LOGIC 2.25 W/RESI

W/ TUBE FENDERS

USE 37/12.50R17 TIRE W/ 17X9 WHEELS W/ 4.5" BS W/ NO TRIMMING
 USE 40/13.50R17 TIRE W/ 17X9 WHEELS W/ 4.5" BS W/ CUTTING

4-DOOR MODELS

K4070M - W/ STEALTH SHOCKS

(50)(153)(154)

- 1 FTS24154 FRONT & REAR LONG TRAVEL COILS
- 1 FTS24128 FRONT & REAR SHORT ARM LOWER LINKS
- 1 FTS24131 LONG TRAVEL BOX KIT
- 2 FTS6016 FRONT STEALTH MONOTUBE
- 2 FTS6349 REAR STEALTH MONOTUBE

K4070DL - W/ DIRT LOGIC NON RESI SHOCKS

(50)(153)(154)

- 1 FTS24154 FRONT & REAR LONG TRAVEL COILS
- 1 FTS24128 FRONT & REAR SHORT ARM LOWER LINKS
- 1 FTS24131 LONG TRAVEL BOX KIT
- 2 FTS810222 FRONT DIRT LOGIC 2.25 NON RESI
- 2 FTS811102 REAR DIRT LOGIC 2.25 NON RESI

K4071DL - W/ DIRT LOGIC RESI SHOCKS

(50)(153)(154)

- 1 FTS24154 FRONT & REAR LONG TRAVEL COILS
- 1 FTS24128 FRONT & REAR SHORT ARM LOWER LINKS
- 1 FTS24131 LONG TRAVEL BOX KIT
- 2 FTS800222 FRONT DIRT LOGIC 2.25 W/RESI
- 2 FTS801102 REAR DIRT LOGIC 2.25 W/RESI

FOOTNOTES: 50. INSTALLATION REQUIRES WELDING.

148. EXHAUST SPACER (FTS24126) REQUIRED ON ALL 2012-16 JEEP WRANGLERS.

151. REQUIRES DRIVESHAFTS 2 DOOR MODEL 07-11 FRONT (FTS94057) REAR (FTS94051).

152. REQUIRES DRIVESHAFTS 2 DOOR MODEL 12-16 FRONT (FTS94057) REAR (FTS94058).

153. REQUIRES DRIVESHAFTS 4 DOOR MODELS 07-11 FRONT (FTS94057) REAR (FTS94052).

154. REQUIRES DRIVESHAFTS 4 DOOR MODEL 12-16 FRONT (FTS94057) REAR (FTS94059).

3" SPORT STANDARD SPRINGS

3" SPORT SYSTEMS INCLUDE

- Standard Coil Springs Front & Rear
- Track Bar Bracket Rear
- Sway Bar Links Front
- Brake Line Drop Bracket Rear
- E Brake Bracket
- Urethane Bump Stops Front
- Bump Stop Brackets Rear
- Available with Dirt Logic 2.25, Stealth or Performance shocks



SPORT SYSTEM

- DIRT LOGIC NON RESI SHOCKS

The Sport system provides increased ride height with four coil springs for light offroad use and daily highway use. The included alignment cams provide adjustability to reset the caster for the 3" lift. As a great entry level suspension it can be upgraded as you go with Fabtech's Short Arm Links for increased strength and durability.

3" SPORT SYSTEMS

W/ STOCK FENDERS

USE 35/12.50R17 TIRE W/ 17X9 WHEELS W/ 4.5" BS W/ MINOR TRIMMING
 USE 35/12.50R18 TIRE W/ 18X9 WHEELS W/ 4.5" BS W/ MINOR TRIMMING
 USE 325/65R18 TIRE W/ 18X9 WHEELS W/ 4.5" BS W/ MINOR TRIMMING
 USE 35/12.50R20 TIRE W/ 20X9 WHEELS W/ 5" BS W/ MINOR TRIMMING
 USE 325/60R20 TIRE W/ 20X9 WHEELS W/ 5" BS W/ MINOR TRIMMING

W/ TUBE FENDERS

USE 37/12.50R17 TIRE W/ 17X9 WHEELS W/ 4.5" BS W/ CUTTING
 USE 37/12.50R18 TIRE W/ 18X9 WHEELS W/ 4.5" BS W/ CUTTING
 USE 37/12.50R20 TIRE W/ 20X9 WHEELS W/ 5" BS W/ CUTTING

2-DOOR MODELS

K4047 - W/ PERFORMANCE SHOCKS

(148)(155)(156)

1 FTS24095 COMPONENT BOX W/ PERFORMANCE SHOCKS

K4047M - W/ STEALTH SHOCKS

(148)(155)(156)

1 FTS24103 COMPONENT BOX W/ STEALTH SHOCKS

K4047DL - W/ DIRT LOGIC SHOCKS

(148)(155)(156)

1 FTS24107 COMPONENT BOX W/ DIRT LOGIC SHOCKS

K4083DL - W/ DIRT LOGIC RESI SHOCKS

(148)(155)(156)

1 FTS24139 COMPONENT BOX W/ DIRT LOGIC RESI SHOCKS

4-DOOR MODELS

K4048 - W/ PERFORMANCE SHOCKS

(148)(157)(158)

1 FTS24097 COMPONENT BOX W/ PERFORMANCE SHOCKS

K4048M - W/ STEALTH SHOCKS

(148)(157)(158)

1 FTS24104 COMPONENT BOX W/ STEALTH SHOCKS

K4048DL - W/ DIRT LOGIC SHOCKS

(148)(157)(158)

1 FTS24108 COMPONENT BOX W/ DIRT LOGIC SHOCKS

K4084DL - W/ DIRT LOGIC RESI SHOCKS

(148)(157)(158)

1 FTS24140 COMPONENT BOX W/ DIRT LOGIC RESI SHOCKS

FOOTNOTES: 148. EXHAUST SPACER (FTS24126) REQUIRED ON ALL 2012-16 JEEP WRANGLERS.

155. HEAVY OFFROAD USE REQUIRES DRIVESHAFTS 2 DOOR MODEL 07-11 FRONT (FTS94057) REAR (FTS94051).

156. HEAVY OFFROAD USE REQUIRES DRIVESHAFTS 2 DOOR MODEL 12-16 FRONT (FTS94057) REAR (FTS94058).

157. HEAVY OFFROAD USE REQUIRES DRIVESHAFTS 4 DOOR MODELS 07-11 FRONT (FTS94057) REAR (FTS94052).

158. HEAVY OFFROAD USE REQUIRES DRIVESHAFTS 4 DOOR MODEL 12-16 FRONT (FTS94057) REAR (FTS94059).

SPORT II 3 INCH

STANDARD SPRINGS



SPORT II SYSTEM
- PERFORMANCE SHOCKS

3" SPORT II SYSTEMS INCLUDE

- Standard Coil Springs Front & Rear
- Adjustable Track Bar Front
- Track Bar Bracket & Support Rear
- Alignment Cams
- Sway Bar Links Front
- Brake Line Drop Bracket Rear
- E Brake Bracket
- Bump Stop Extensions Front
- Bump Stop Brackets Rear
- Available with Dirt Logic 2.25, Stealth or Performance shocks

3" SPORT II SYSTEMS

W/ STOCK FENDERS

USE 35/12.50R17 TIRE W/ 17X9 WHEELS W/ 4.5" BS W/ MINOR TRIMMING
 USE 35/12.50R18 TIRE W/ 18X9 WHEELS W/ 4.5" BS W/ MINOR TRIMMING
 USE 325/65R18 TIRE W/ 18X9 WHEELS W/ 4.5" BS W/ MINOR TRIMMING
 USE 35/12.50R20 TIRE W/ 20X9 WHEELS W/ 5" BS W/ MINOR TRIMMING
 USE 325/60R20 TIRE W/ 20X9 WHEELS W/ 5" BS W/ MINOR TRIMMING

2-DOOR MODELS

K4085 - W/ PERFORMANCE SHOCKS

(148)(155)(156)

- 1 FTS24161 FRONT & REAR COIL KIT - 2 DOOR
- 1 FTS24129 1.75"-5" CHROMOLY FRONT TRACK BAR
- 1 FTS24178 COMPONENT BOX
- 2 FTS7236 FRONT PERFORMANCE SHOCK
- 2 FTS7265 REAR PERFORMANCE SHOCK

K4085M - W/ STEALTH SHOCKS

(148)(155)(156)

- 1 FTS24161 FRONT & REAR COIL KIT - 2 DOOR
- 1 FTS24129 1.75"-5" CHROMOLY FRONT TRACK BAR
- 1 FTS24178 COMPONENT BOX
- 2 FTS6061 FRONT STEALTH SHOCK
- 2 FTS6265 REAR STEALTH SHOCK

K4085DL - W/ DIRT LOGIC SHOCKS

(148)(155)(156)

- 1 FTS24161 FRONT & REAR COIL KIT - 2 DOOR
- 1 FTS24129 1.75"-5" CHROMOLY FRONT TRACK BAR
- 1 FTS24178 COMPONENT BOX
- 2 FTS810582 FRONT DIRT LOGIC 2.25 NON RESI
- 2 FTS811092 REAR DIRT LOGIC 2.25 NON RESI

W/ TUBE FENDERS

USE 37/12.50R17 TIRE W/ 17X9 WHEELS W/ 4.5" BS W/ CUTTING
 USE 37/12.50R18 TIRE W/ 18X9 WHEELS W/ 4.5" BS W/ CUTTING
 USE 37/12.50R20 TIRE W/ 20X9 WHEELS W/ 5" BS W/ CUTTING

4-DOOR MODELS

K4086 - W/ PERFORMANCE SHOCKS

(148)(157)(158)

- 1 FTS24162 FRONT & REAR COIL KIT - 4 DOOR
- 1 FTS24129 1.75"-5" CHROMOLY FRONT TRACK BAR
- 1 FTS24178 COMPONENT BOX
- 2 FTS7236 FRONT PERFORMANCE SHOCK
- 2 FTS7265 REAR PERFORMANCE SHOCK

K4086M - W/ STEALTH SHOCKS

(148)(157)(158)

- 1 FTS24162 FRONT & REAR COIL KIT - 4 DOOR
- 1 FTS24129 1.75"-5" CHROMOLY FRONT TRACK BAR
- 1 FTS24178 COMPONENT BOX
- 2 FTS6061 FRONT STEALTH SHOCK
- 2 FTS6265 REAR STEALTH SHOCK

K4086DL - W/ DIRT LOGIC SHOCKS

(148)(157)(158)

- 1 FTS24162 FRONT & REAR COIL KIT - 4 DOOR
- 1 FTS24129 1.75"-5" CHROMOLY FRONT TRACK BAR
- 1 FTS24178 COMPONENT BOX
- 2 FTS810582 FRONT DIRT LOGIC 2.25 NON RESI
- 2 FTS811092 REAR DIRT LOGIC 2.25 NON RESI

1.75" SPACER

INCH.



For those that want a minimal lift height with fast and easy installation this polyurethane spacer kit is perfect. This kit with tube fenders allows installation of 35" tires keeping the vehicle's center of gravity low with increased ground clearance at the axles.

1.75" SPACER KIT

W/ STOCK FENDERS

USE 295/70R17 TIRE W/ 17X9 WHEELS W/4.5" BS W/ MINOR TRIMMING
USE 325/60R18 TIRE W/ 18X9 WHEELS W/4.5" BS W/ MINOR TRIMMING
USE 305/55R20 TIRE W/ 20X9 WHEELS W/4.5" BS W/ MINOR TRIMMING

W/ TUBE FENDERS

USE 35/12.50R17 TIRE W/ 17X8 WHEELS W/ 5" BS W/ MINOR TRIMMING
USE 35/12.50R18 TIRE W/ 18X9 WHEELS W/ 5" BS W/ MINOR TRIMMING
USE 325/65R18 TIRE W/ 18X9 WHEELS W/ 5" BS W/ MINOR TRIMMING
USE 35/12.50R20 TIRE W/ 20X9 WHEELS W/ 5" BS W/ MINOR TRIMMING
USE 325/60R20 TIRE W/ 20X9 WHEELS W/ 5" BS W/ MINOR TRIMMING

2 & 4-DOOR MODELS

K4087 - W/O SHOCKS

1 FTS24180 COMPONENT BOX ONLY

K4088M - W/ STEALTH SHOCKS

1 FTS24182 COMPONENT BOX W/ STEALTH SHOCKS

K4088 - W/ PERFORMANCE SHOCKS

1 FTS24181 COMPONENT BOX W/ PERFORMANCE SHOCKS

FOOTNOTES: 148. EXHAUST SPACER (FTS24126) REQUIRED ON ALL 2012-16 JEEP WRANGLERS.
155. HEAVY OFFROAD USE REQUIRES DRIVESHAFTS 2 DOOR MODEL 07-11 FRONT (FTS94057) REAR (FTS94051).
156. HEAVY OFFROAD USE REQUIRES DRIVESHAFTS 2 DOOR MODEL 12-16 FRONT (FTS94057) REAR (FTS94058).
157. HEAVY OFFROAD USE REQUIRES DRIVESHAFTS 4 DOOR MODELS 07-11 FRONT (FTS94057) REAR (FTS94052).
158. HEAVY OFFROAD USE REQUIRES DRIVESHAFTS 4 DOOR MODEL 12-16 FRONT (FTS94057) REAR (FTS94059).

SPACER 3 INCH



3" SPACER KIT
STEALTH SHOCKS

This kit utilizes the factory coil springs with 3" tall spacers to obtain lift while keeping the stock ride. Kit includes front and rear track bar brackets that recenters the axles under the vehicle for the increased ride height. An economical and correct way to lift a JK for 35" tires with all the proper bracketry included.

3" SPACER SYSTEMS INCLUDE

- Coil Spring Spacers Front & Rear
- Track Bar Brackets Front & Rear
- Pitman Arm
- Sway Bar Links Front
- Bump Stop Extensions Front
- Bump Stop Brackets Rear
- Available with Dirt Logic 2.25, Stealth or Performance shocks



3" SPACER KIT - PERFORMANCE SHOCKS
35/12.50R17 TIRE W/ 17X9 WHEELS W/ 5" BS

3" SPACER KIT

W/ STOCK FENDERS

USE 35/12.50R17 TIRE W/ 17X9 WHEELS W/ 4.5" BS W/ MINOR TRIMMING
 USE 35/12.50R18 TIRE W/ 18X9 WHEELS W/ 4.5" BS W/ MINOR TRIMMING
 USE 325/65R18 TIRE W/ 18X9 WHEELS W/ 4.5" BS W/ MINOR TRIMMING
 USE 35/12.50R20 TIRE W/ 20X9 WHEELS W/ 5" BS W/ MINOR TRIMMING
 USE 325/60R20 TIRE W/ 20X9 WHEELS W/ 5" BS W/ MINOR TRIMMING

W/ TUBE FENDERS

USE 37/12.50R17 TIRE W/ 17X9 WHEELS W/ 4.5" BS W/ CUTTING
 USE 37/12.50R18 TIRE W/ 18X9 WHEELS W/ 4.5" BS W/ CUTTING
 USE 37/12.50R20 TIRE W/ 20X9 WHEELS W/ 5" BS W/ CUTTING

2 & 4-DOOR MODELS

K4037 - W/ PERFORMANCE SHOCKS

(148)(155)(156)(157)(158)

- 1 FTS24080BK COMPONENT BOX
- 2 FTS7236 FRONT PERFORMANCE SHOCKS
- 2 FTS7182 REAR PERFORMANCE SHOCKS

K4037DL - W/ DIRT LOGIC SHOCKS

(148)(155)(156)(157)(158)

- 1 FTS24080BK COMPONENT BOX
- 2 FTS810582 FRONT DIRT LOGIC 2.25 NON RESI
- 2 FTS811092 REAR DIRT LOGIC 2.25 NON RESI

K4037M - W/ STEALTH SHOCKS

(148)(155)(156)(157)(158)

- 1 FTS24080BK COMPONENT BOX
- 2 FTS6021 FRONT STEALTH SHOCKS
- 2 FTS6265 REAR STEALTH SHOCKS

ACCESSORIES

[COILOVER CONVERSIONS]

The front and rear Dirt Logic 2.5 Coilover conversion provides outstanding high speed damping with the ability to crawl at low speed with maximum articulation for big rocks.

- Front Coilover positioned at centerline of axle to prevent premature link bushing wear
- Rear system subframe strengthens frame for longevity
- Allows for 12" of usable wheel and articulation travel



3" FRONT COILOVER CONVERSION SYSTEM

- 1 FTS24185 FRONT COILOVER MOUNTS
- 1 FTS24137 FRONT DIRT LOGIC 2.5 COILOVERS W/RESI

5" FRONT COILOVER CONVERSION SYSTEM

- 1 FTS24136 FRONT COILOVER MOUNTS
- 1 FTS24106 FRONT DIRT LOGIC 2.5 COILOVERS W/RESI

3" REAR COILOVER CONVERSION SYSTEM (160)

- 1 FTS24109 REAR COILOVER MOUNTS
- 1 FTS24153 REAR DIRT LOGIC 2.5 COILOVERS W/RESI

5" REAR COILOVER CONVERSION SYSTEM (160)

- 1 FTS24109 REAR COILOVER MOUNTS
- 1 FTS24127 REAR DIRT LOGIC 2.5 COILOVERS W/RESI

Rear heavy capacity coilover springs provide approx. 150-200lbs. extra weight carrying capacity.

5" HEAVY CAPACITY COILOVER SPRINGS - PAIR

- 1 FTS24179 REAR - 2 & 4 DOOR

[DIRT LOGIC SHOCKS]



Dirt Logic 2.25 features a stainless steel body for maximum corrosion resistance. Race quality componentry and vehicle specific valving provides an outstanding ride quality.

3" STANDARD SYSTEMS

2 FTS810582 FRONT DIRT LOGIC 2.25 NON RESI
2 FTS811092 REAR DIRT LOGIC 2.25 NON RESI

2 FTS800582 FRONT DIRT LOGIC 2.25 W/RESI
2 FTS801092 REAR DIRT LOGIC 2.25 W/RESI

3" LONG TRAVEL SYSTEMS

2 FTS811182 FRONT DIRT LOGIC 2.25 NON RESI
2 FTS811092 REAR DIRT LOGIC 2.25 NON RESI

2 FTS801182 FRONT DIRT LOGIC 2.25 W/RESI
2 FTS801092 REAR DIRT LOGIC 2.25 W/RESI

5" SYSTEMS

2 FTS810222 FRONT DIRT LOGIC 2.25 NON RESI
2 FTS811102 REAR DIRT LOGIC 2.25 NON RESI

2 FTS800222 FRONT DIRT LOGIC 2.25 W/RESI
2 FTS801102 REAR DIRT LOGIC 2.25 W/RESI

[PERFORMANCE SHOCKS]



3" STANDARD SYSTEMS

2 FTS7236 FRONT PERFORMANCE SHOCK
2 FTS7265 REAR PERFORMANCE SHOCK

FOOTNOTES: 160. REQUIRES MAGNAFLOW EXHAUST.
2 DOOR PN 15236. 4 DOOR PN 15237.

[STEALTH SHOCKS]



The Stealth monotube shock is built with a 46mm diameter high flow piston and is valved specifically for Jeep JK's with oversized tires.

3" STANDARD SYSTEMS

2 FTS6021 FRONT STEALTH SHOCK
2 FTS6265 REAR STEALTH SHOCK

3" LONG TRAVEL SYSTEMS

2 FTS6016 FRONT STEALTH SHOCK
2 FTS6265 REAR STEALTH SHOCK

5" SYSTEMS

2 FTS6016 FRONT STEALTH SHOCK
2 FTS6349 REAR STEALTH SHOCK

[SHOCK MOUNTS]



FRONT LOWER SHOCK MOUNT RELOCATION BRACKETS

1 FTS2411 FOR USE WITH 3" LONG TRAVEL



HIGH CLEARANCE REAR LOWER SHOCK MOUNTS

1 FTS2411 SHOCK MOUNTS

ACCESSORIES

[STEERING STABILIZERS]

Provides increased damping for the steering system of the vehicle to reduce tire shake caused by large tires both on and offroad.



STEERING STABILIZER KIT - HI CLEARANCE

1 FTS24169 DIRT LOGIC 2.25 NON RESI SHOCK

STEERING STABILIZER KIT - HI CLEARANCE

1 FTS24168 STEALTH MONOTUBE SHOCK

STEERING STABILIZER - HI CLEARANCE

1 FTS24112 BRACKETS ONLY

STEERING STABILIZER - FACTORY POSITION

1 FTS8024 PERFORMANCE TWIN TUBE SHOCK

STEERING STABILIZER - FACTORY POSITION

1 FTS6605 STEALTH MONOTUBE SHOCK

STEERING STABILIZER - FACTORY POSITION

1 FTS240911 DIRT LOGIC 2.25 NON RESI SHOCK



DUAL STEERING STABILIZER KIT

1 FTS8053 STEALTH MONOTUBE SHOCKS

[DIRT LOGIC BUMP STOPS]

For aggressive high speed offroad driving Dirt Logic 2.25 bump stops will provide increased damping to the suspension at full compression. Two styles of front bump stop kits for use with either factory coil springs or Dirt Logic Coilover conversion. The rear kit is for custom fabrication requiring frame modification and welding.



FRONT DIRT LOGIC 2.25 BUMP STOP KIT (159)

1 FTS24155 OE POSITION



FRONT DIRT LOGIC 2.25 BUMP STOP KIT

1 FTS24186 USE WITH 3" COILOVER CONVERSION

1 FTS240892 USE WITH 5" COILOVER CONVERSION

REAR DIRT LOGIC 2.25 BUMP STOP ONLY

1 FTS840042 4" TRAVEL

REAR WELD ON BUMPSTOP CAN ONLY

1 FTS90079 REAR WELD ON BUMPSTOP CAN

[COIL SPRINGS]



FRONT

REAR

3" STANDARD COIL SPRING KIT

1 FTS24161 FRONT & REAR - 2 DOOR

3" STANDARD COIL SPRING KIT

1 FTS24162 FRONT & REAR - 4 DOOR



FRONT

REAR

3" DUAL RATE LONG TRAVEL COIL SPRING KIT

1 FTS24163 FRONT & REAR - 2 DOOR

3" DUAL RATE LONG TRAVEL COIL SPRING KIT

1 FTS24164 FRONT & REAR - 4 DOOR

3" DUAL RATE LONG TRAVEL COIL SPRINGS - PAIR

1 FTS24174 FRONT - 2 & 4 DOOR

3" DUAL RATE LONG TRAVEL COIL SPRINGS - PAIR

1 FTS24165 REAR - 2 DOOR

3" DUAL RATE LONG TRAVEL COIL SPRINGS - PAIR

1 FTS24166 REAR - 4 DOOR

5" DUAL RATE LONG TRAVEL COIL SPRING KIT

1 FTS24143 FRONT & REAR - 2 DOOR

5" DUAL RATE LONG TRAVEL COIL SPRING KIT

1 FTS24154 FRONT & REAR - 4 DOOR

5" DUAL RATE LONG TRAVEL COIL SPRINGS - PAIR

1 FTS24175 FRONT 2 & 4 DOOR

5" DUAL RATE LONG TRAVEL COIL SPRINGS - PAIR

1 FTS24145 REAR - 2 DOOR

5" DUAL RATE LONG TRAVEL COIL SPRINGS - PAIR

1 FTS24146 REAR - 4 DOOR

FOOTNOTES: 159. REMOVAL OF FACTORY BUMPSTOP REQUIRED.

ACCESSORIES

TRACK BARS & BRACKETS



Constructed of 1-3/4" OD Chromoly tubing with 3/4" PTFE lined heim end and vulcanized bushing.

1.75"-5" FRONT TRACK BAR

1 FTS24129 FRONT ADJUSTABLE CHROMOLY



Constructed of 1.5" OD Chromoly tubing with 3/4" PTFE lined heim end and vulcanized bushing.

1.75"-5" REAR TRACK BAR

1 FTS24167 REAR ADJUSTABLE CHROMOLY



3"-5" FRONT TRACK BAR BRACKETS

1 FTS24113 FRONT WELD ON



3"-5" REAR TRACK BAR BRACKETS

1 FTS24114 REAR WELD ON



3"-5" FRONT TRACK BAR BRACKETS

1 FTS24125 FRONT BOLT ON W/SUPPORT



3"-5" REAR TRACK BAR BRACKETS

1 FTS24115 REAR BOLT ON W/SUPPORT

[LINK ARMS]



LINK ARMS W/5 TON JOINTS (PAIR)

3"-5" LIFT / 1.250" OD X .120" WALL DOM TUBING

1 FTS24123 SHORT ARM FRONT UPPER LINKS



LINK ARMS W/5 TON JOINTS (PAIR)

3"-5" LIFT / 1.75" OD X .250" WALL DOM TUBING

1 FTS24117 SHORT ARM FRONT LOWER LINKS



LINK ARMS W/5 TON JOINTS (PAIR)

3"-5" LIFT / 1.50" OD X .120" WALL DOM TUBING

1 FTS24116 SHORT ARM REAR UPPER LINKS



LINK ARMS W/5 TON JOINTS (PAIR)

3"-5" LIFT / 1.75" OD X .250" WALL DOM TUBING

1 FTS24122 SHORT ARM REAR LOWER LINKS



LINK ARMS W/5 TON JOINTS (PAIR)

3"-5" LIFT / 1.75" OD X .250" WALL DOM TUBING

1 FTS24128 SHORT ARM FRONT & REAR LOWER LINKS



LINK ARMS W/POLY BALL JOINTS (PAIR)

3"-5" LIFT / 1.250" OD X .120" WALL DOM TUBING

1 FTS24118 SHORT ARM FRONT UPPER LINKS



LINK ARMS W/POLY BALL JOINTS (PAIR)

3"-5" LIFT / 1.75" OD X .250" WALL DOM TUBING

1 FTS24120 SHORT ARM FRONT LOWER LINKS



LINK ARMS W/POLYURETHANE BUSHINGS (PAIR)

3"-5" LIFT / 1.50" OD X .120" WALL DOM TUBING

1 FTS24133 SHORT ARM REAR UPPER LINKS



LINK ARMS W/POLY BALL JOINTS (PAIR)

3"-5" LIFT / 1.75" OD X .250" WALL DOM TUBING

1 FTS24121 SHORT ARM REAR LOWER LINKS

ACCESSORIES

[LINK ARM JOINTS]

Ultra heavy duty joint with quiet ride. Lifetime warranty against wearing out. Guaranteed.



LARGE 5 TON JOINT™

1 FTS50412 1" BALL - 1.5" DIAMETER THREAD



SMALL 5 TON JOINT™

1 FTS50413 7/8" BALL - 1.25" DIAMETER THREAD

Traditional style joint with urethane bushings and steel inner ball construction



LARGE POLY BALL

1 FTS50397 1" BALL - 1.5" DIAMETER THREAD



SMALL POLY BALL

1 FTS50124 7/8" BALL - 1.25" DIAMETER THREAD

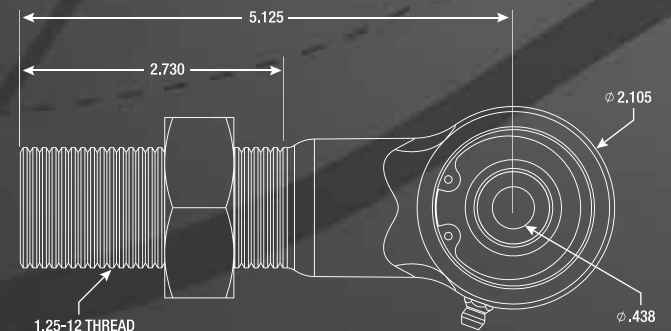
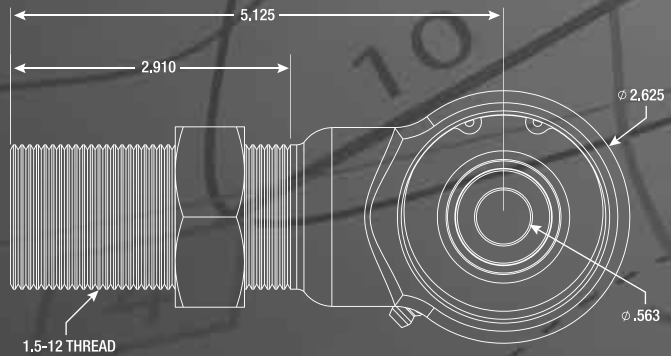
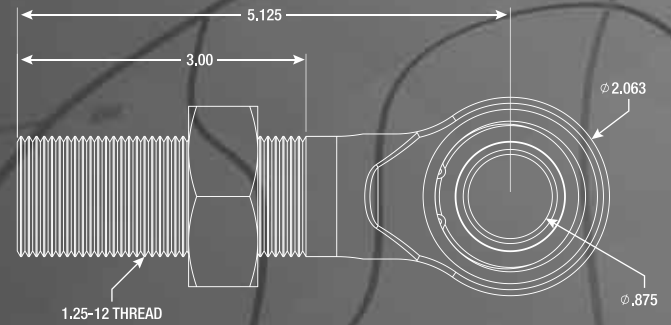
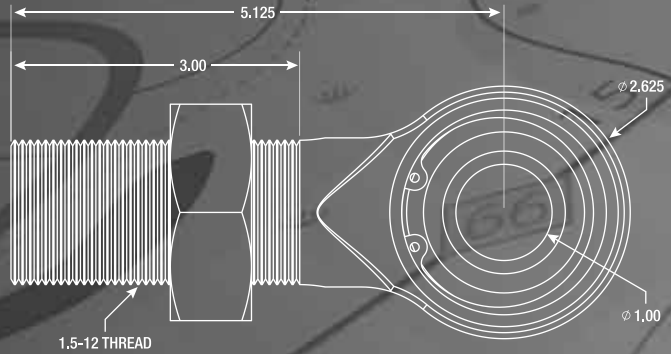

[POLY BALL JOINT REBUILD KITS]



LARGE POLY BALL JOINT REBUILD

1 FTS94009 COMPLETE KIT



SMALL POLY BALL JOINT REBUILD

1 FTS94010 COMPLETE KIT



LARGE POLY BALL BUSHINGS

1 FTS90110 LARGE POLY BALL BUSHINGS ONLY



SMALL POLY BALL BUSHINGS

1 FTS90109 SMALL POLY BALL BUSHINGS ONLY

[MISALIGNMENTS]



5 TON JOINT™ - LARGE

1 FTS50415 1" MISALIGNMENTS - PAIR



5 TON JOINT™ - SMALL

1 FTS50414 7/8" MISALIGNMENTS - PAIR

[BRAKE LINES]

DOT Compliant. Front & Rear 23".



1 FTS94061 FRONT & REAR EXTENDED BRAKE LINE KIT W/RETURN SPRINGS

1 FTS94062 FRONT EXTENDED BRAKE LINE KIT W/RETURN SPRINGS

1 FTS94063 REAR EXTENDED BRAKE LINE KIT W/RETURN SPRINGS

ACCESSORIES

[SWAY BAR LINKS]



3"-5" FRONT SWAY BAR LINKS

1 FTS24158 SWAY BAR LINK KIT - FIXED



3"-5" FRONT SWAY BAR LINKS & DISCONNECT

1 FTS94056 SWAY BAR LINKS & DISCONNECT KIT



3"-5" REAR SWAY BAR LINKS

1 FTS24159 SWAY BAR LINK KIT - FIXED

[DRIVESHAFTS]



1 FTS94057 FRONT DRIVESHAFT - 2007-16 (2 & 4 DOOR)



1 FTS94058 REAR DRIVESHAFT - 2012-16 (2 DOOR)

1 FTS94051 REAR DRIVESHAFT - 2007-11 (2 DOOR)



1 FTS94059 REAR DRIVESHAFT - 2012-16 (4 DOOR)

1 FTS94052 REAR DRIVESHAFT - 2007-11 (4 DOOR)

[GUSSETS]



FRONT AXLE UPPER LINK MOUNT GUSSET

1 FTS24156 GUSSET KIT - WELD ON



For use with rear Coilover system.

REAR UPPER LINK POCKET GUSSET

1 FTS24110 GUSSET KIT - WELD ON

[EXHAUST SPACERS]



1 FTS24126 EXHAUST SPACER



1 FTS94060 EXHAUST LOOP DELETE

[ALIGNMENT CAMS]



ADJUSTABLE ALIGNMENT CAM KIT - FRONT

1 FTS50297 ADJUSTABLE ALIGNMENT CAM KIT

[PITMAN ARM]



1 FTS50294 DROPPED PITMAN ARM - 3"-5" LIFT