



DUAL VOLTAGE ICE BOX

CONVERSION SYSTEM

120 VOLTS A.C. & 12/24 VOLTS D.C.

MODELS

SCQT-4408F-U1-L

SCQT-4408F-U1-I

OWNER'S GUIDE

SAWAFUJI ELECTRIC CO.,LTD.

General :

This appliance is designed to convert a sailboat ice box to a mechanically refrigerated box. The conversion unit is available in a 40 watt system and can operate on both A.C. and D.C. power supplies. Unlike a standard self contained refrigerator, the cooling plate is separated from the compressor / condenser unit by flexible refrigerant lines. The conversion requires installing the cooling plate in the ice box and installing the compressor / condenser unit in a well ventilated location within the 3.6m of available refrigerant tubing.

CAUTION

- Never store gasoline or other flammable vapors and liquids as these sometimes cause explosion.
- Do not touch evaporator and metal parts of cabinet inside by wet hand. Sometimes, it may cause frostbite to your hand.
- Do not remove modify all the electrical live parts to avoid electric shock and trouble of your refrigerator.

Specification

Model	SCQT-4408F-U1-L	SCQT-4408F-U1-I
Input rating	AC120V	0.7A
	DC12/24V	2.5A/1.3A
Refrigerant	HFC-134a	
Weight	Approx. 12kg	

A.

Identification of parts – unpack the conversion unit and check for damaged or missing parts.

	SCQT-4408F-U1-L	SCQT-4408F-U1-I
Exterior Dimensions [mm]	359(W) × 242(L) × 148(H)	
Dimensions of Evaporator [mm]	406(L1) × 215(L2) × 270(H)	523(L1) × 225(H)
Length of Suction Tube [m]	3.6	
Length of A.C. Cord [m]	1.6	
Length of D.C. Cord [cm]	15	
Length of Thermostat Cord [m]	1.0	
Thermostat Box: Exterior Dimensions [m]	84(H) × 50(W) × 40(D)	
Accessories: Evaporator Standoff	6 pieces	4 pieces

B.

Required Tools :

6.4mm dia Drill and Assorted Bits
32mm dia Hole Saw
21mm and 24mm Wrenches or 2 Adjustable Wrenches
Phillips and Straight Screwdrivers
Wire Cutters and/or Wire Strippers
Electrician Tape and Wire Connectors
Tube of Silicone

C.

Location of Components :

Before the installation work is begun, the layout of the entire system should be considered, with particular attention to the following points :

- Location and position of the cooling plate.
- Point of tubing exit from ice box.
- Thermostat mounting position.
- Route of refrigerant tubing.
- Location of compressor/condenser unit.

There are two basic positions which are acceptable for the cooling plate as shown in Fig. 3(a). Positions shown in Figs. 3(b),(c) or 3(f) will result in unacceptable cooling performance. For top opening boxes, the position as shown in Fig.3(a) is the most common. It is preferable to install the cooling plate(s) as high in the box as possible to obtain good circulation of cold air and more uniform temperatures. Placement of the compressor/condenser is very important, since ventilation is a major consideration. The unit depends upon the convection air around it to remove its heat.

DO NOT PLACE THE COMPRESSOR/CONDENSER IN A CONFINED SPACE WHICH RECEIVES

NO VENTILATION.

Availability of space for the compressor/condenser is usually found beneath or behind the companion way, lazaretto, quarter berth or settee.

At times, the engine compartment may be considered but many times not recommended because of the heat produced from the engine. The important point is that the space must be well ventilated. If the location is closed to air movement, it may be possible to

cut openings in panels and, if necessary, provide louvered panels (available at marine supply).

The best venting arrangement in a confined space is to provide an opening below, or low on the side, and an opening at the top, or high on the side.

The size of the lower and upper openings should be an equivalent of 650 square cm minimum free opening for each.

See Fig 4. Allow several inches on each side and top of the unit for accessibility and ventilation.

Before the compressor/condenser location is selected, measure the exact route of the refrigerant tubing to insure the unit is within reach.

Also, the top of the compressor/condenser unit must not be installed higher than 50 cm above the cooling plate to insure sufficient circulation of refrigerant oil.

Before deciding on the compressor/condenser location, there should be assurance that the electrical wiring will be accessible to the unit, both A.C. and D.C. supplies.

D. Installation

For the purpose of keeping a sufficient circulation of refrigeration oil;

*Altitude of compressor to evaporator

Set the evaporator within 50cm in altitude to the compressor head if the evaporator is installed at higher position than the compressor.

IMPORTANT DIRECTIONS FOR TUBE BENDING

① ORIGINAL STATE (AS RECEIVED)

- The copper suction tube is clamped at the nearest point to the Evaporator. (Refer to Figure 1, Point A.)
- The tube is bent in a tight U-shape at Point "B". (Refer to Figure 1, Point B.)
- The remaining part of the tube to the connecting coupler is rolled in a large diameter "L". (Refer to Figure 1, "L".)

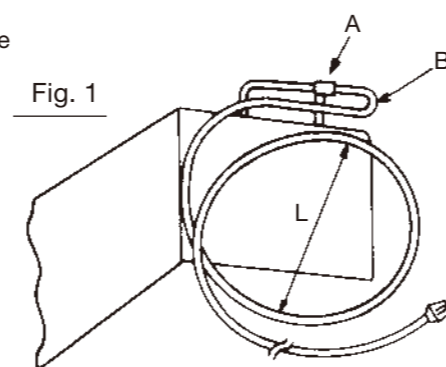

② DIRECTIONS FOR UNCOILING SUCTION TUBE

- Carefully straighten the coiled tube indicated by "L" so that the tube position is similar to the position shown in Figure 2.

- When the Evaporator is installed into the cabinet, retain the tight U-shape bend indicated at point "B". The tube section at "C" must not be moved or altered so as to protect the connector to the Evaporator as indicated by point "D".

- In case the installation requires the tube to be run in Direction "E", then use Figure 2 as a guide.

On the other hand, if the tube is to be run in another direction (G, F, H, I), carefully bend the tube at point "K".

For reference, the type of bend for various directions (G, F, H, I) is shown where "K" is the point of bending.

In case of "G" direction.

In case of "F" direction.

In case of "H" direction.

In case of "I" direction.

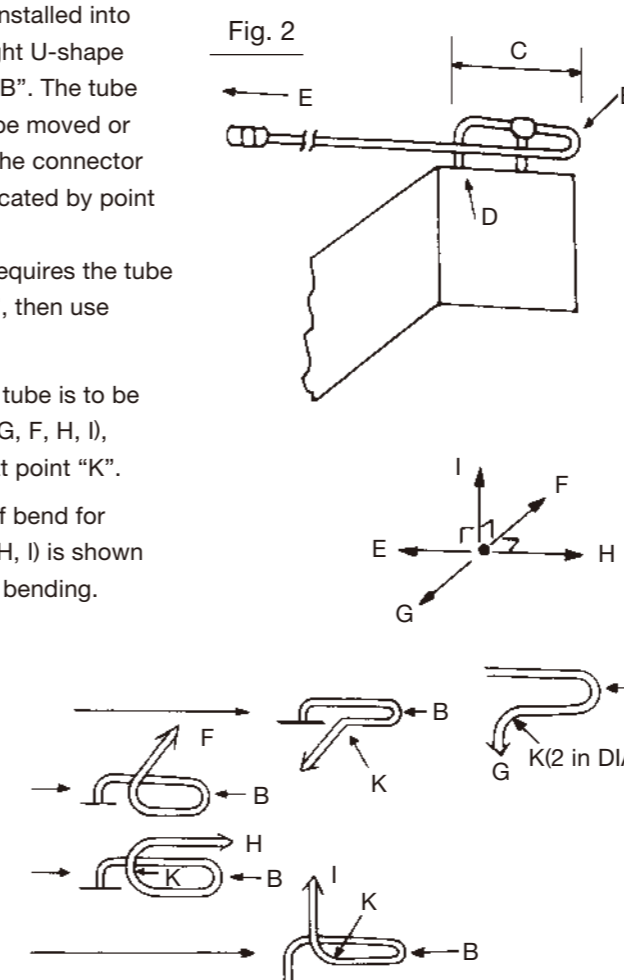

Important : In making the tube bend at point "K", a tube bending tool should be used. If not available, the tube can be hand bent using a wooden or metal cylindrical shape of approximately 50-65mm diameter.

IN CASE OF "G" DIRECTION

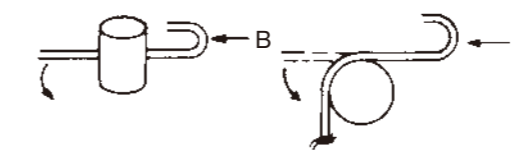

Caution : Use extreme care in hand bending so as not to kind, flatten or damage the copper tube.

- Insert the evaporator in storage compartment and secure it (with screws provided) on the vertical side wall of the compartment using the evaporator standoff. (Fig. 2).
Do not kink or excessively bend tubing since this can not only cause damage but can restrict free flow of refrigerant.
Cover the suction tube with insulation material, such as neoprene sponge, tube or fiberglass tape, outside of the refrigerating box.
Caution : The refrigerant quick connect couplings must be kept clean and dry. Do not remove dust caps and plugs until ready to make the connections.
- The compressor/condenser case can be easily mounted to the floor mounting brackets and by use of screws or bolts, (Fig 6) Place unit to insure accessibility and good circulation (see paragraph on location).
- Set the thermostat box side wall of the refrigerating box, within reach, referring to (Fig. 7) Turn the thermostat control knob to the "off" position.

E.

With the power supplies off, make the electrical connections, referring to (Fig. 9). Refer to **WIRE SIZE** table for recommended D.C. wire sizes.

Important : The D.C. wire connection should be made to a dedicated 12/24 volts supply with a circuit breaker. This 12/24 volts must be a battery -not a converter or battery charger.
See (Fig. 10).

F. Connection of Refrigerant Couplings

- Remove dust caps and plugs if used, making sure that components synthetic seals are intact. It is best to complete connection to the lower coupling before making the next connection.
- Wipe off coupling seals and threaded surfaces with a clean cloth to prevent the inclusion of dirt or any foreign material in the system.
- Lubricate rubber seal in made half with a thin coat of oil. Thread coupling halves together by hand to insure proper mating of threads.

Note : one set of couplings connects to the mating set on the compressor/condenser unit. The threads are such that the two lines cannot be reversed.

At this point make sure two proper sized wrenches are available, since the tightening should be done rapidly to minimize any refrigerant loss (you may hear a brief "hiss" as the joint is tightened).

CAUTION : Always turn the female coupling and hold the male coupling with the second wrench.

Use proper size wrenches (on coupling body hex and union nut) and tighten until coupling bodies "bottom" or definite resistance is felt.
Using a maker or ink pen, mark a line lengthwise from the coupling hex to the bulkhead. Then tighten an additional 1/6 to 1/4 turn.
The misalignment of the line will show the degree of tightening.
The final turn is necessary to insure that the knife edge metal seal bites into the brass seat of the coupling halves, forming the leakproof joint. If torque wrench is used, the following torque values are recommended.

Coupling Size : No. 6; Torque : 230kgf. cm-270kgf. cm

After all couplings are tight, leak check the joint with a soap solution.

G. Connecting to Power Source :

Your refrigerator can be operated on A.C. (120 volts) from the wall socket or D.C. (12/24 volts) from a battery. 12/24 volts D.C. Operation in Your Boat, Trailer, Camper, Etc.

The car battery voltage varies with the type of car you own. Most cars and boats use a 12 volts system. Your refrigerator needs a 12/24 volts battery. See (Fig. 10) If the battery voltage is too high (for example 32 volt) your refrigerator can not cool On the other hand, its cooling power will decrease if the voltage is lower than 12 volts.

Set the thermostat control knob to "OFF". Connect two (2) wires from the battery, REFERRING TO PLUS/MINUS (+/-) INDICATIONS.

CAUTION

CONNECT REFRIGERATOR DIRECT TO BATTERY

The battery must have a charging means available, such as a generator, converter or the alternator. If not, the battery will discharge in a short period of time. Any switches, lead wires or other electrical equipment should not be common with wiring between your refrigerator and battery, because this equipment often generates high voltage pulses and causes transistor trouble in the power – supply. See (Fig. 10).

On D.C. operation, connecting the D.C. supply properly to the refrigerator is important. You will note that one lead wire is marked (+) positive and the other (-) negative.

If the polarity be reversed, The unit does not operate and does not light thermostat lamp, check the fuse located in D.C. lead and the polarity of the D.C. power supply.

If it still does not operate, this is an indication that other problem exist in the inverter, and the unit should be checked by an authorized distributor. To reduce the radio interference and induction of a high surge voltage from the outside, twisting of the lead wire is important. See (Fig. 11).

H. Operational Check :

After completing the final installation details, an operational check can be made by watching the thermostat control knob to "ON" and turning the temperature control dial from 1 to 5 until the compressor starts. After a few minutes, the cooling plates should feel cold indicating circulation of refrigerant. Check on both A.C. and D.C. operation.

NOTE : Built in relay switches automatically to correct power supply.

- Suppose the refrigerator is operating on 120 volts A.C. (shore-power connection on boat dock, etc.) and then the power source is disconnected by a switch or by pulling the plug, the relay automatically switches the refrigerator over to the 12/24 volts D.C. power source and continues to operate the compressor, providing, of course, the leads are connected to the battery.
- If the refrigerator is operating normally on a 12/24 volts battery, then, when 120 volts A.C. power is switched on or by just plugging in the A.C. power cord, the relay switches the compressor over to A.C. operation. This will save on power consumption and keep your battery in good condition. Refrigerating temperature can be controlled by means of the temperature control dial. The interior temperature drops as the dial position is changed from "1" to "5". In this way, interior temperatures can be regulated freely within the range of 7.2°C to 0°C. To switch off your refrigerator, move the thermostat control knob to "OFF". The dial does not turn clockwise beyond "1" and "5".
For efficient operation, regulate the temperature according to the types of foods stored.
- MAINTENANCE OF BATTERY IS IMPORTANT**
If the charge of your battery is not sufficient, a decline in the cooling performance of your refrigerator can be expected. If 120 V, electric power supply is available, A.C. operation is recommended to keep your battery in good condition. A.C. power is AUTOMATICALLY applied, if your vehicle's 120 volts electric system is connected to the outside 120 V power supply.
- NEVER EMPLOY A "QUICK CHARGER" TO YOUR BATTERY UNLESS THERMOSTAT POWER SWITCH HAS BEEN TURNED TO "OFF".**

e. NEVER USE A COMMERCIAL 12/24 VOLTS D.C. TO 120VOLTS A.C., INVERTER OR CONVERTER for operating your refrigerator on A.C., since these devices do not hold the required constant frequency.

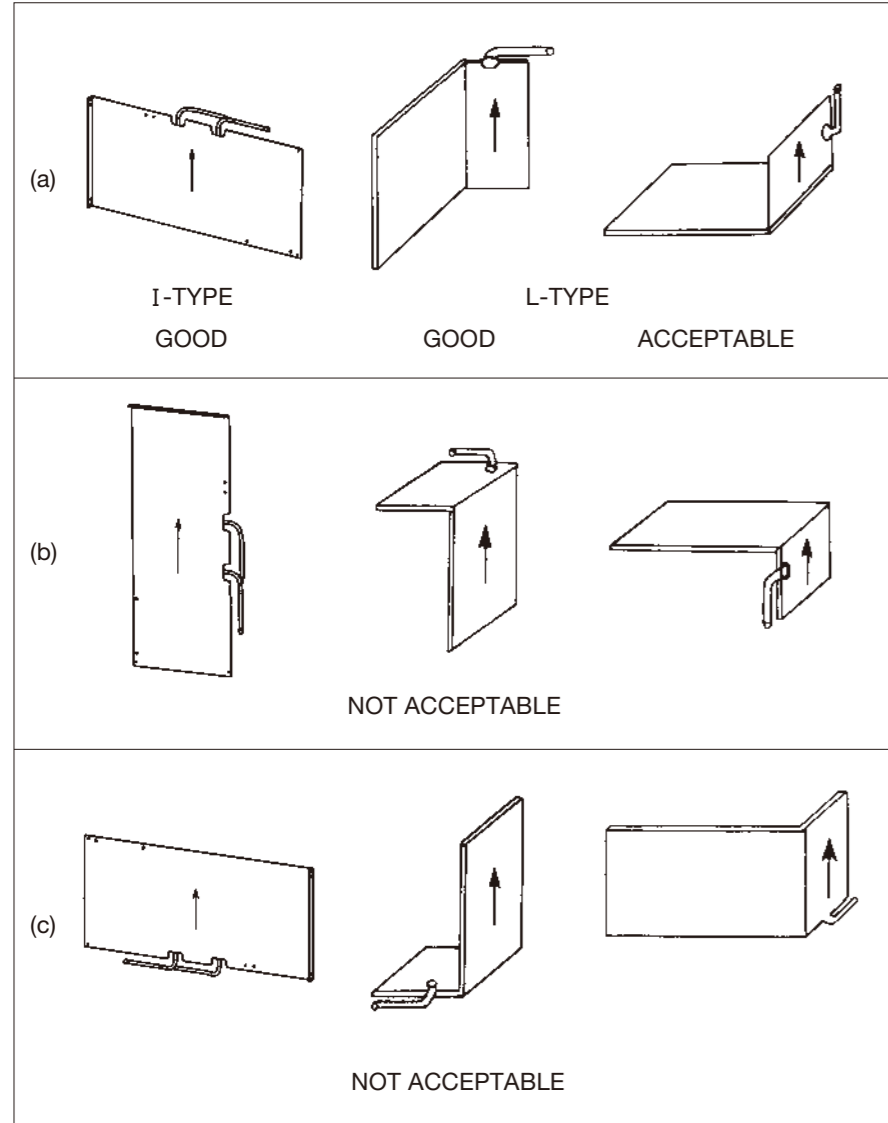

Fig. 3

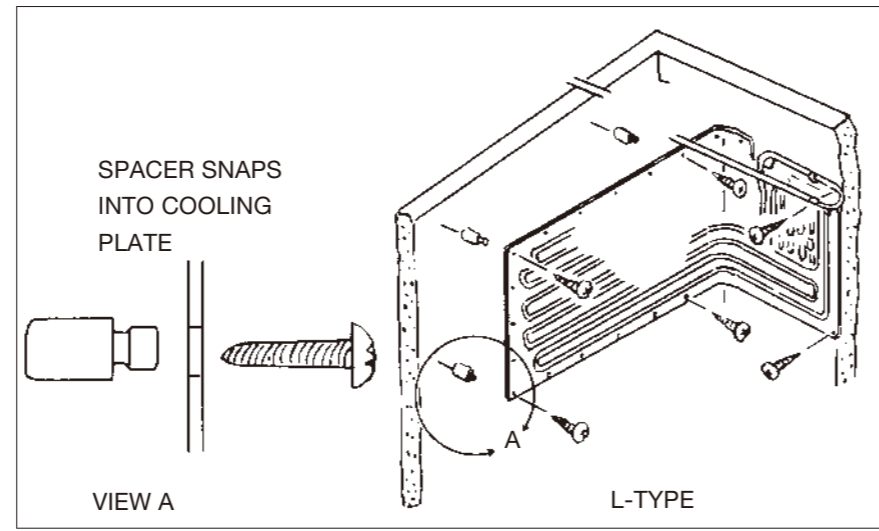

Fig. 5

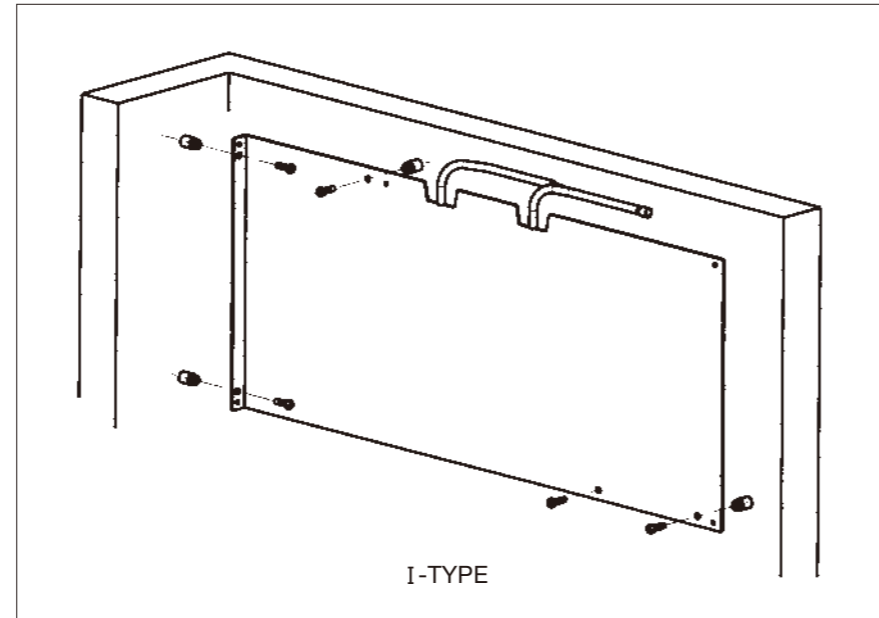

Fig. 6

WIRE SIZE tables for field supplied D.C. cord (to battery)

Length of Field Supplied Wire	WIRE SIZE
Less than 1.8m	SWG #16 (AWG #14)
1.8m to 3.6m	SWG #16 (AWG #14)
3.6m to 6m	SWG #14 (AWG #12)

Fig. 9

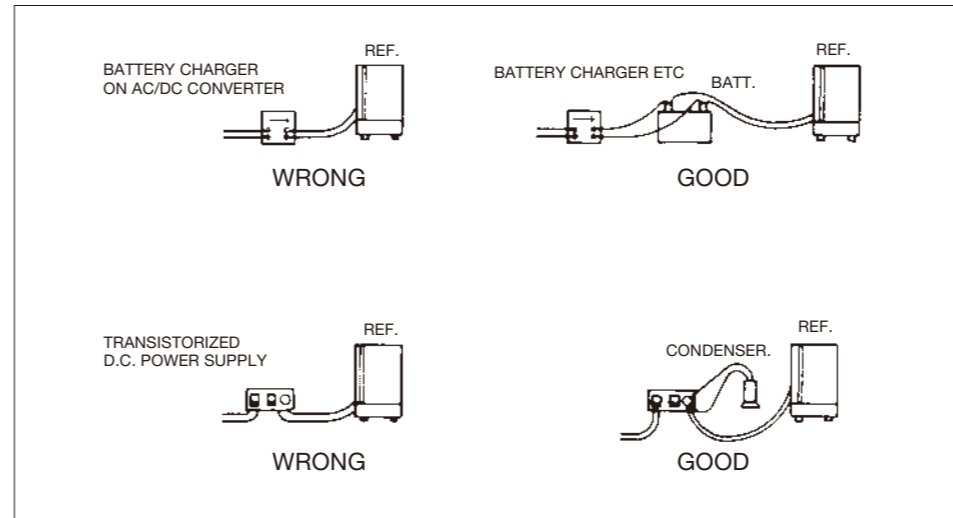

Fig. 10

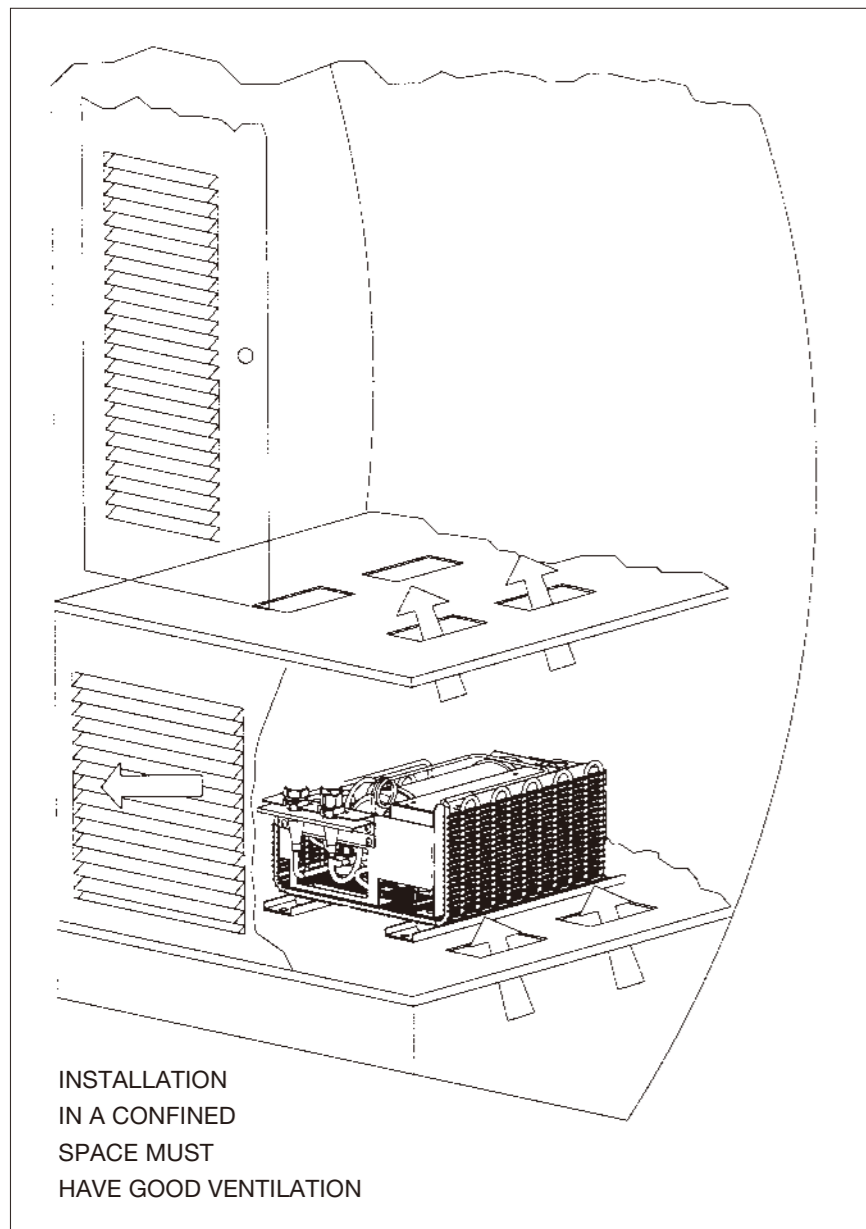

Fig. 4

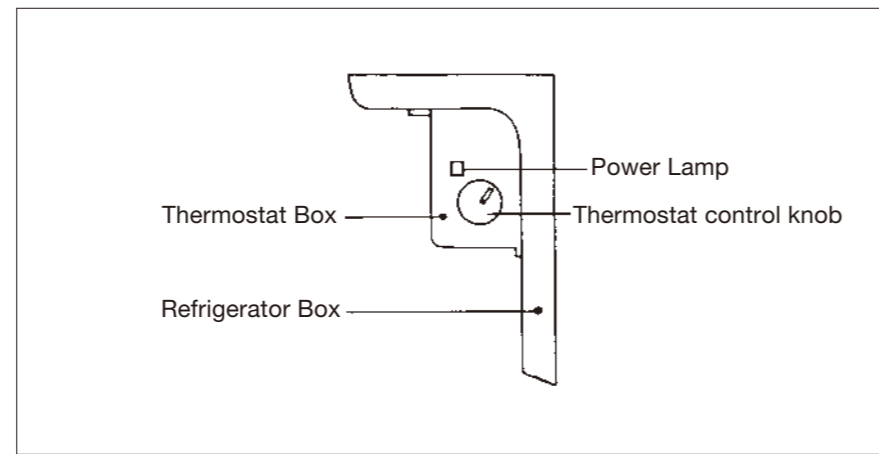

Fig. 7

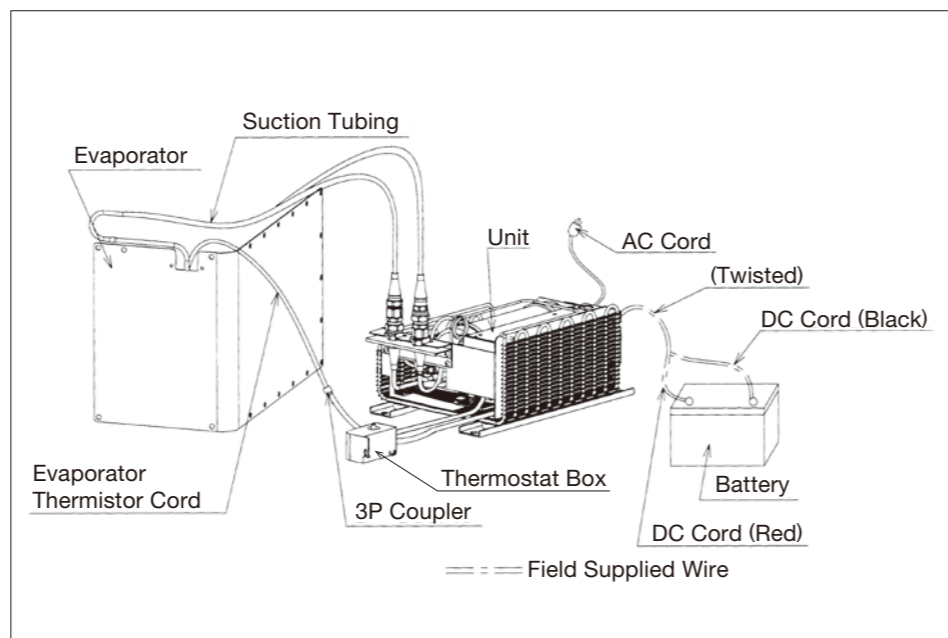

Fig. 8

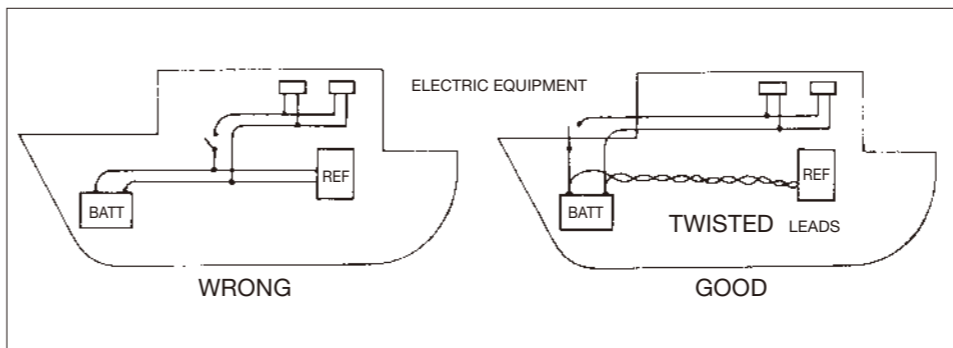

Fig. 11

Technical data

Model	SCQT-4408F-U1-L	SCQT-4408F-U1-I
Max. cooling capacity with 50mm PU insulation thickness.	100 litres 0 °C or less	50 litres 0 °C or less

It is data in ambient-air-temperature regularity of 30 °C, and an unloaded condition.

● Please be sure to install the machinery on a level surface. When the machinery is installed at a tilt, unusual sound may occur.

● When tilted, Unusual sound from compressor may occur in the vibration from the outside. This is not unusual. Neither performance nor a function is influenced.