

INSTALLATION INSTRUCTIONS



NO POWER TOOLS

- Do not use power tools to install this product.
- No Battery operated screws guns.
- The use of power tools during installation may void the product warranty.
- Do not overtighten.

INSTALLATION INSTRUCTIONS

- 1 • Open hood.
 - Remove 6 upper fixing nuts located behind grill as shown.
 - Loosen 4 side fixing nuts located behind grill as shown. Do not remove nuts fully. **WARNING : GRILL MAY BECOME DETACHED AND FALL FORWARD.**
- 2 • Remove protective film from **PROTECTOR/DEFLECTOR**.
 - Position one end of **PROTECTOR/DEFLECTOR** between grill and hood.
 - Rotate **PROTECTOR/DEFLECTOR** into final position between grill and hood. Ensure **PROTECTOR/DEFLECTOR** is fully located.
- 3 • Replace six upper fixing nuts and tighten.
 - Tighten the four side nuts previously loosened.

To Remove: Reverse above procedure.
To Clean: Use mild detergent and water solution. (Do **NOT** use solvents).
 Avoid the use of automatic "Brush Style" car washes.
 When closing the hood, do **NOT** pull on **PROTECTOR/DEFLECTOR**.

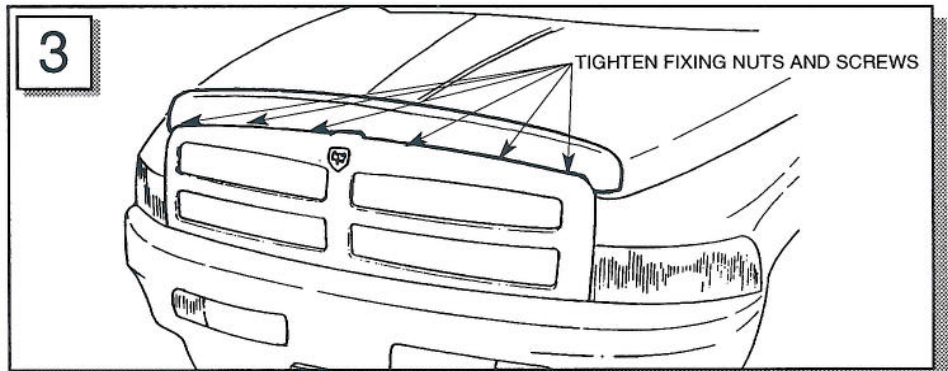
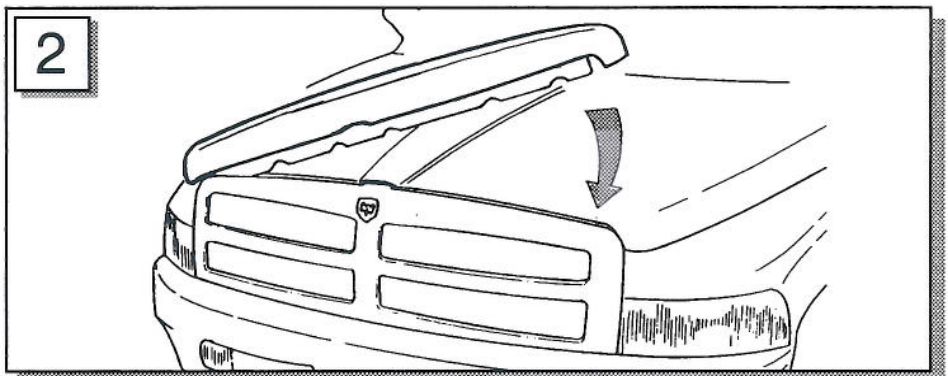
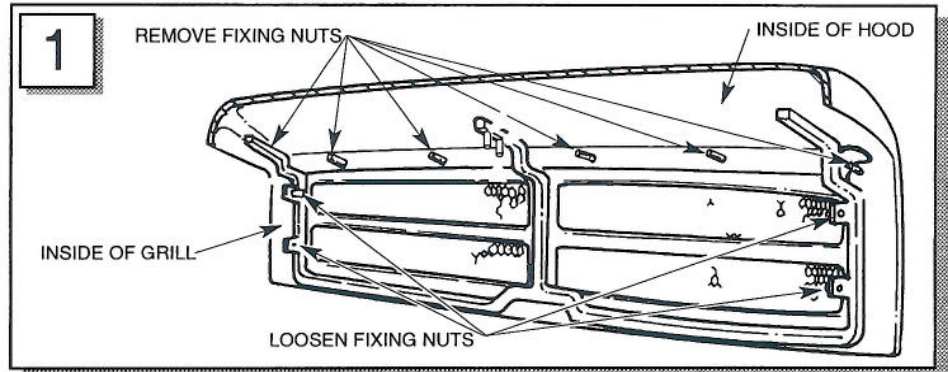

INSTALLATION INSTRUCTIONS



- Do not use power tools to install this product.
- No Battery operated screws guns.
- The use of power tools during installation may void the product warranty.
- Do not overtighten.

FENDER SECTION INSTALLATION INSTRUCTIONS

- 1 Apply dual-lok and bumpers to rear face of **PROTECTOR/DEFLECTOR** in positions shown.
 - 2 Open hood.
 - Trial fit **PROTECTOR/DEFLECTOR** on vehicle fender above headlights.
 - Ensure bottom of product aligns with bottom edge of fender above headlight. Front tag on **PROTECTOR/DEFLECTOR** is fixed between metal body panel and rubber trim using screws nuts and washers provided.
 - Remove rubber trim retaining plugs co-incident with holes in **PROTECTOR/DEFLECTOR**.
 - Note areas where dual-lok contacts fenders then remove **PROTECTOR/DEFLECTOR**.
 - 3 Clean installation areas on vehicle fender with alcohol wipes provided then wipe dry with a clean dry cloth.
 - 4 Peel liner from dual-lok.
 - 5 Secure **PROTECTOR/DEFLECTOR** to vehicle fenders using screws, nuts and washers provided, apply firm pressure on dual-lok sections for maximum adhesion.
- **Note:** To allow tape to cure do not remove **PROTECTOR/DEFLECTOR** for 48 hours.

To Remove: Gently pull on fender sections to release dual-lok.

To Clean: Use mild detergent and water solution. (Do **NOT** use solvents). Avoid the use of automatic "Brush Style" car washes.

WARNING: DO NOT INSTALL AT TEMPERATURES BELOW 10°C (50°F). IDEAL INSTALLATION TEMPERATURE IS BETWEEN 20°C - 40°C (70° - 105°F). WILL ADHERE SUCCESSFULLY AT TEMPERATURES BELOW 10°C AFTER INITIAL CURING. FULL TAPE STRENGTH IS ACHIEVED AFTER 72 HRS. IMPORTANT: ALLOW THE TAPE TO CURE FOR 4 HOURS BEFORE DRIVING VEHICLE.

