

IMPORTANT: PLEASE KEEP THIS INSTRUCTION MANUAL FOR FUTURE REFERENCE !



2012 Acura TL Mesh Overlay Grille

Part #: Complete 1402-0102-12 / "Black Ice" Part #1402-B102-12



TOOLS REQUIRED

Small door panel or thin release tool, automotive grade masking tape, 9 & 10mm socket and ratchet, long flat blade screwdriver, scissors, awl, 1/8", 5/16" & 3/8" drill bits, electric drill, vibrating saw or jig saw, small disc grinder, flat or semi-gloss black paint, extra long nosed pliers, razor blade or X-Acto knife, glass cleaner and soft clean cloths.

H 04 H1 R

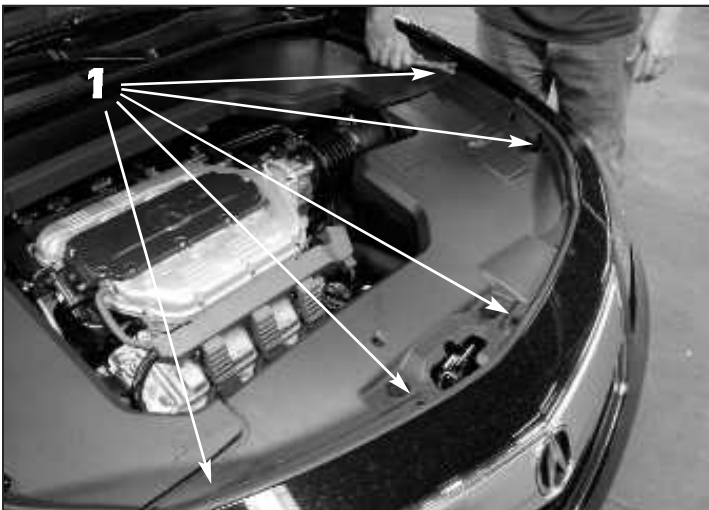

1. Remove the radiator support panel cover by lifting the panel straight up to release the clips or pull the panel straight up to release the clips and remove the cover (to be reinstalled).



2. Apply several layers of masking tape where the grille meets the lower portion of the bumper cover and where the upper portion of the bumper cover separates from the lower section (not shown).

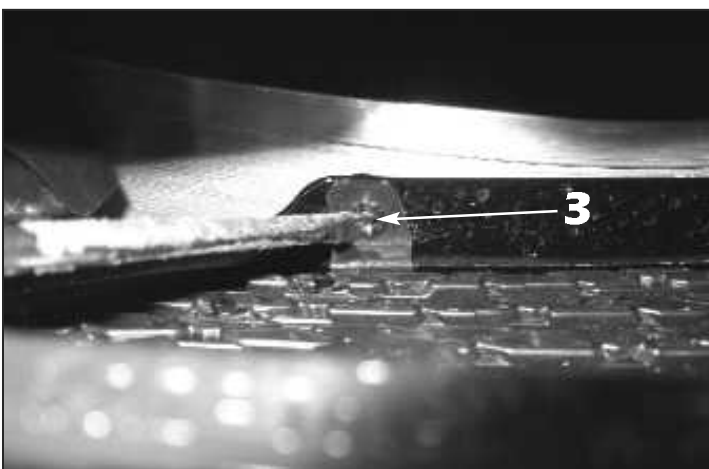

3. Pull the top edge of the grille forward until you can access the six (6) lower mounting push pins. Use a long flat blade screwdriver and push down on the center portion of the push pins until they release, then reach down and remove the push pins (save two for reinstallation). The two (2) outer pins secure the upper and lower portions of the bumper cover together.

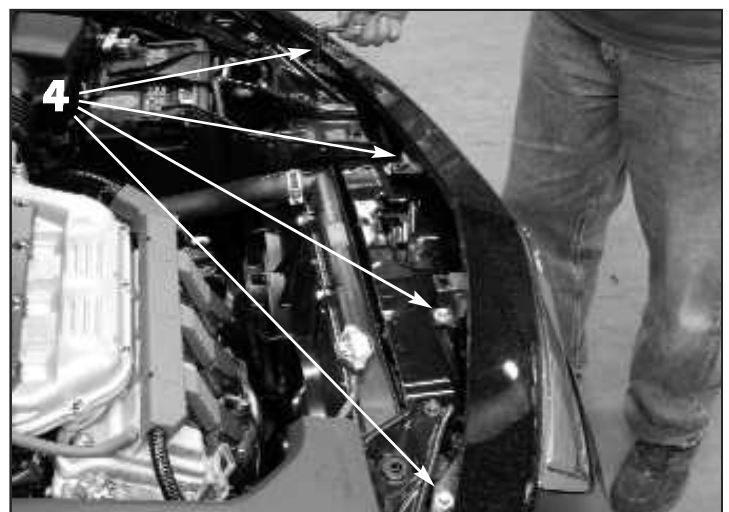

4. Remove the four (4) 10mm factory bolts.

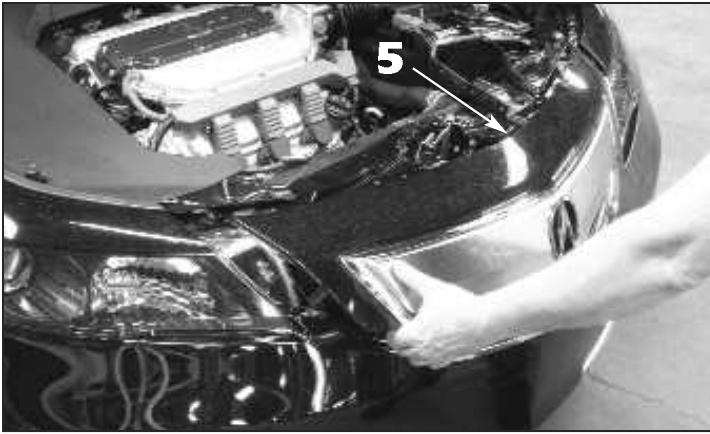

5. Once the lower push pins are removed, pull the grille straight out to remove.

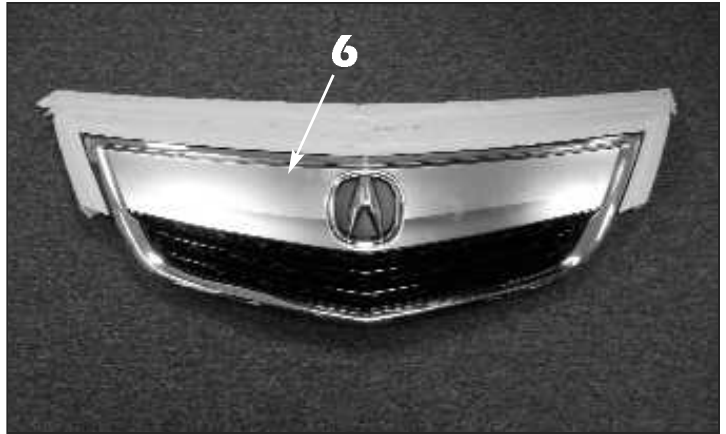

6. Apply protective masking tape to the painted grille surround.

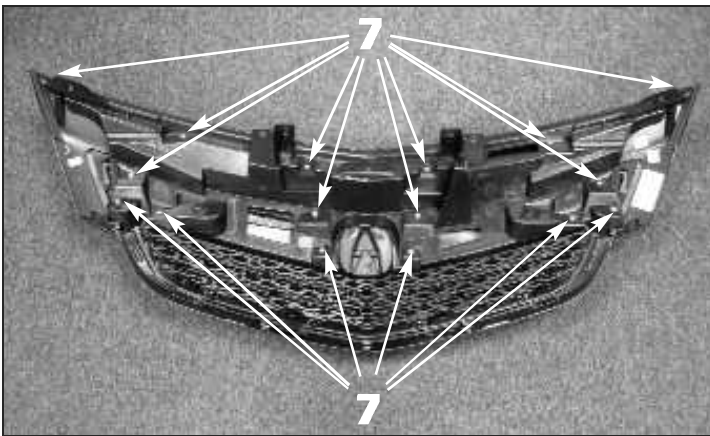

7. Remove all the factory torx screws securing the chrome trim to the front of the factory grille. Remove the wide satin chrome moulding. The narrow chrome frame is still held in place with mounting tabs.



8. Apply masking tape to the factory emblem.



9. Use a flat blade screwdriver to push on the centers of the mounting tabs around the sides and bottom of the factory grille to begin removal of the chrome moulding.

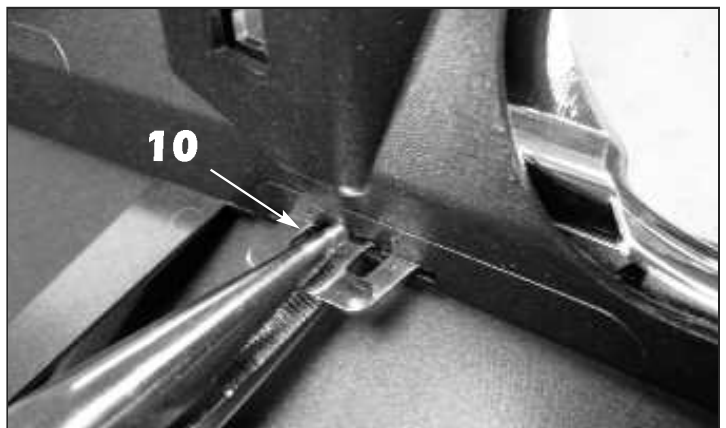

10. Use long nosed pliers to squeeze the mounting tabs will pushing outward to finish removing the factory chrome grille trim.

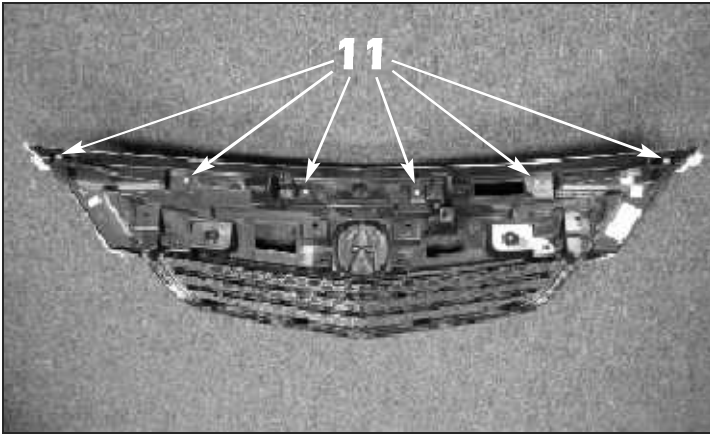

11. Reinstall the factory grille to the painted surround using the factory torx screws.

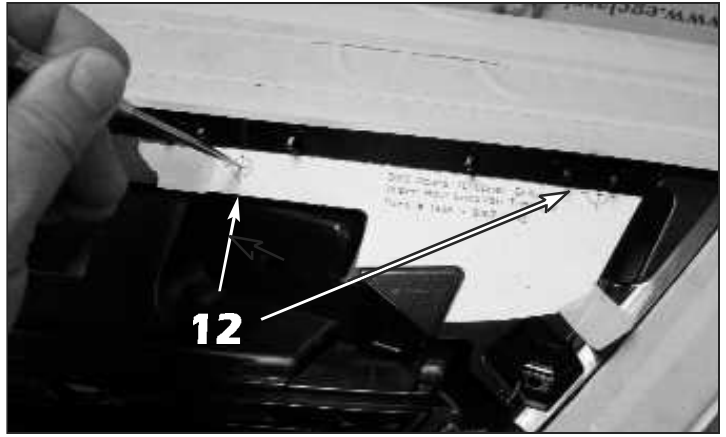

12. Cut out the supplied templates and align the upper grille upper hole location template into place, use masking tape to hold it in place, then use an awl or similar pointed tool to mark the grille at the hole locations.

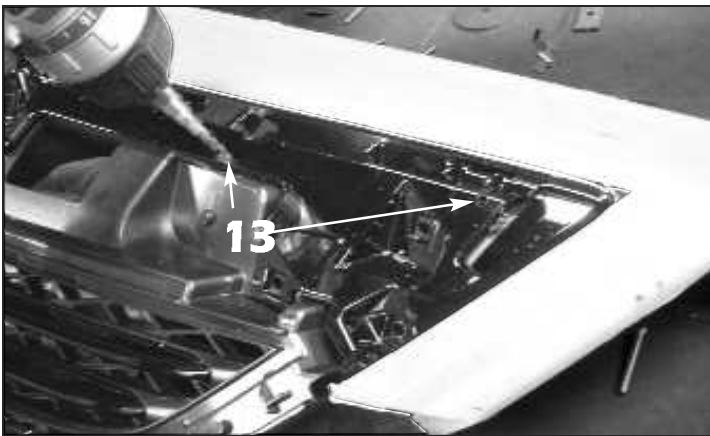

13. Use a 5/16" drill bit to drill through the marks made in the previous step.

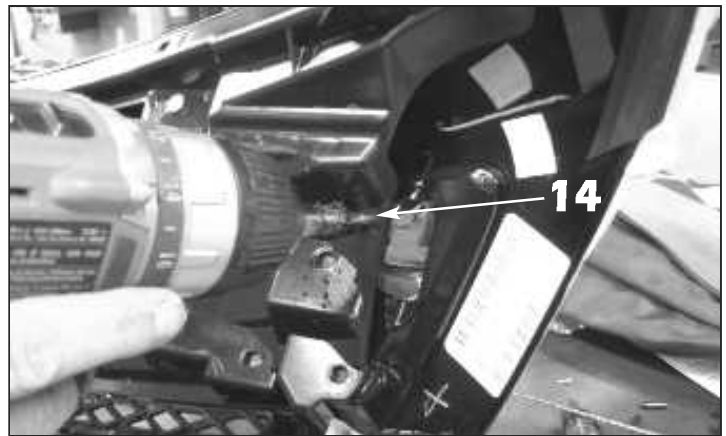

14. Turn the grille over a slightly enlarge the holes to 7/16". Enlarge the upper factory torx screw holes on both left and right sides of the factory emblem to 7/16".

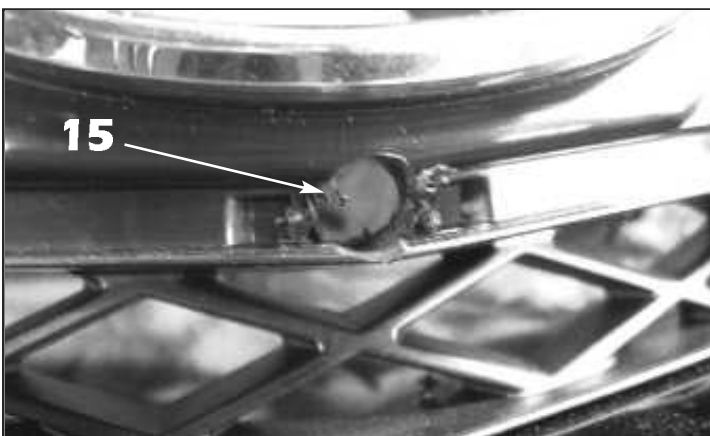

15. Locate the center recessed area directly underneath the factory emblem and drill through the center with a 5/16" drill bit.



16. Using a vibrating saw or jig saw, remove the lower portion of the factory grille, cutting even with the top of the mesh style openings. **Keep the saw away from the painted portion of the factory grille.**

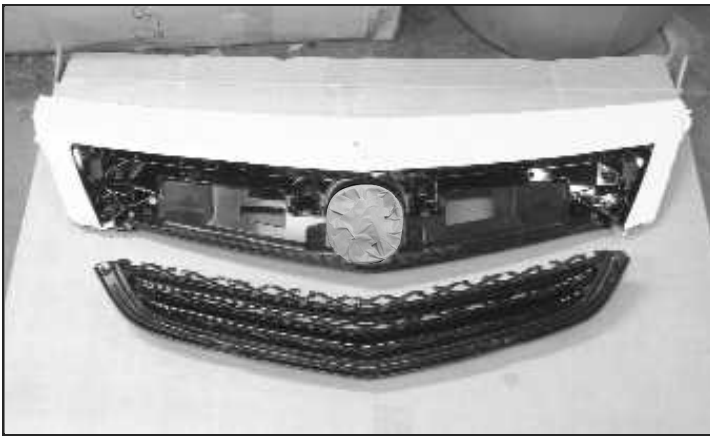

17. View showing the lower portion separated from the upper.

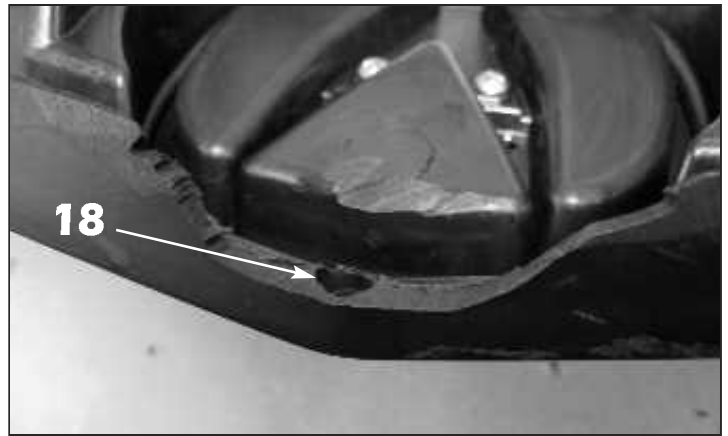

18. Use a disc grinder to smooth any rough edges across the bottom edge of the upper grille section. Make sure you grind down the lower back edge of the plastic until it is flush with the hole drilled in Step 15.

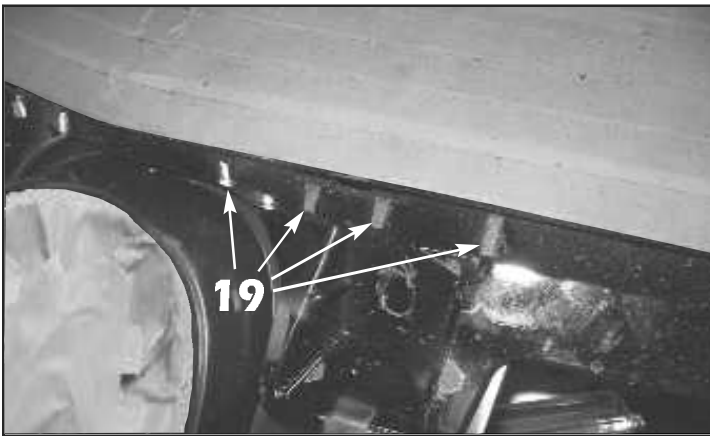

19. Use a disc grinder or long nosed pliers to remove the small raised sections across the top center portion of the upper grille section.

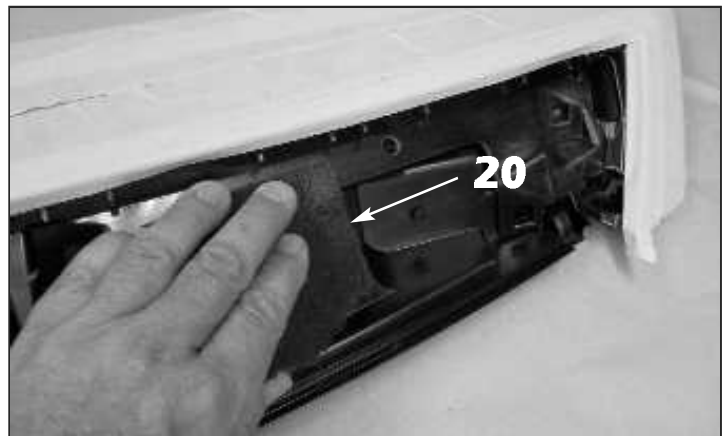

20. **For vehicles painted colors other than black or dark blue:** Use masking tape and tape 1/4" inside the grille opening and use a scotch brite pad to scuff the plastic to be painted.

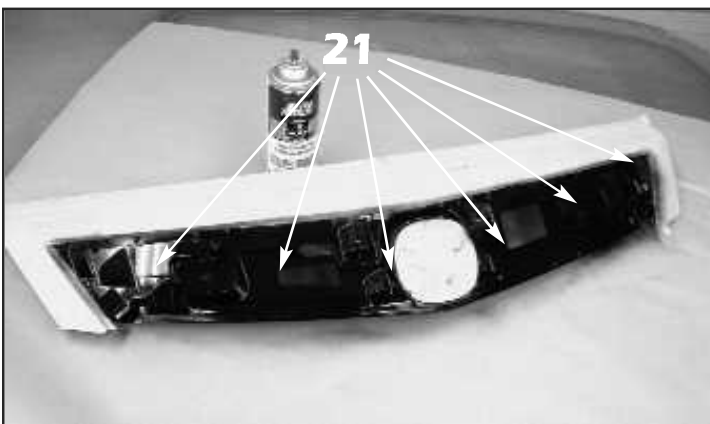

21. Apply semi-gloss black paint to the remaining portion of the factory grille. Allow the paint to dry before mesh grille assembly.

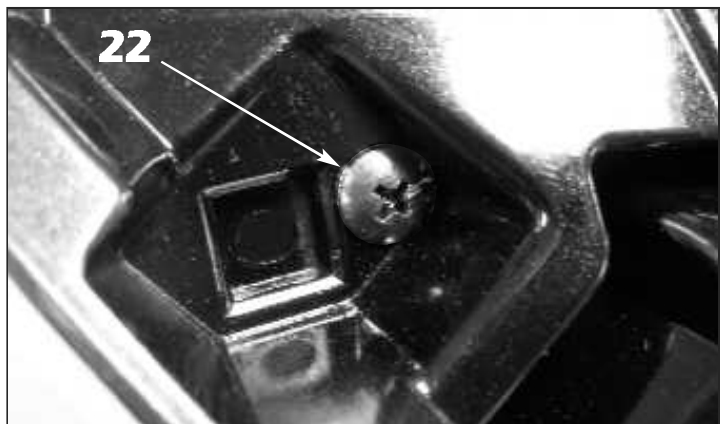

22. Drill a .125" (1/8") hole where shown and install the supplied #8 x 1/2" black truss head screws (one per side) to help secure the painted portion of the grille to the reinforcement at the lower outer corners.

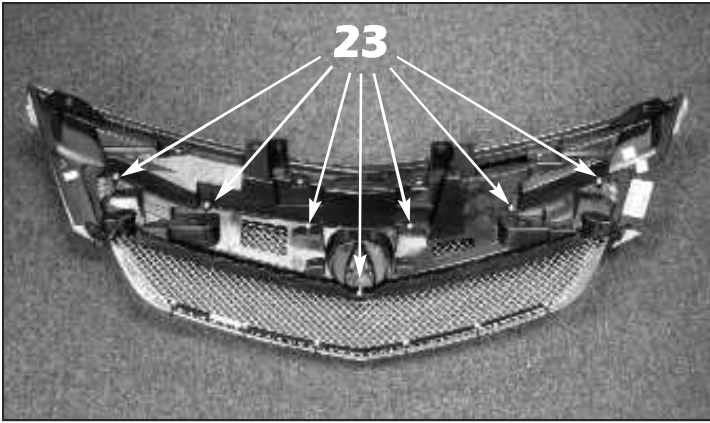

23. Attach the E&G grille to the upper grille section using the supplied small black plastic washers and #8-32 ESNA half nuts. Tighten until the surround is flush with the painted portion of the factory grille and just below the lower surface of the emblem.

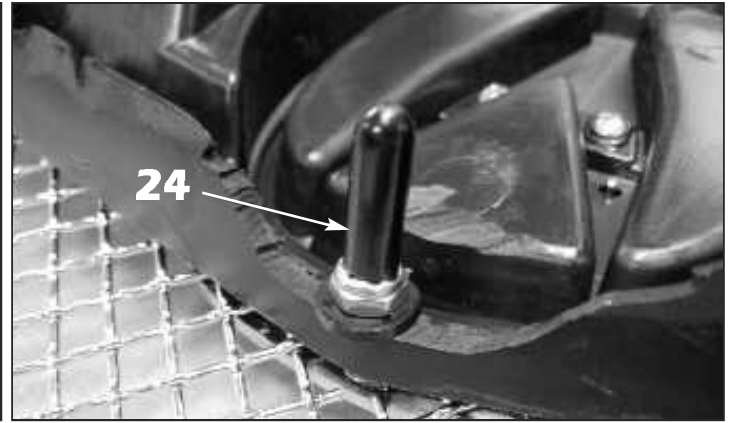

24. Install one of the black cap plugs over the stud below the emblem to help conceal it.

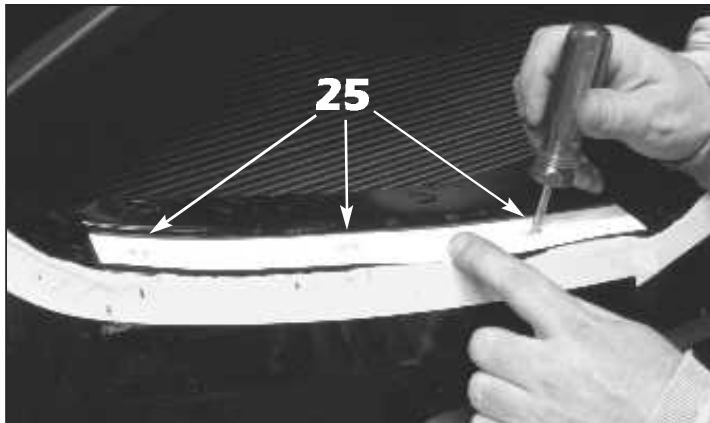

25. Measure and mark the center of the factory grille section. Cut out and align the upper grille lower hole location template and tape it into place. Use an awl or similar pointed tool to mark the hole locations, untape the template, flip it over and mark the holes on the opposite side.

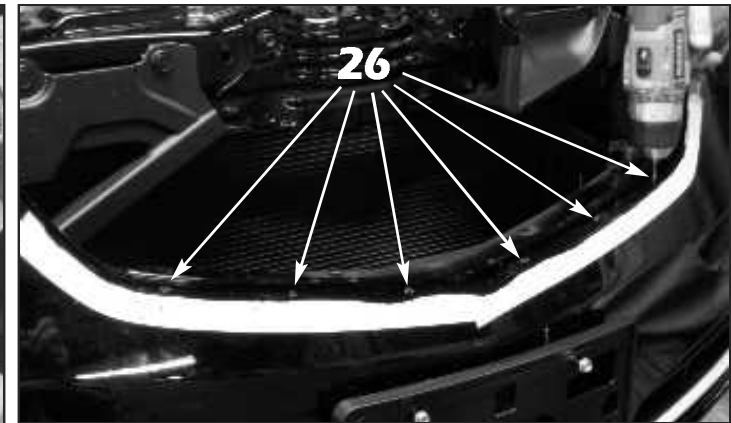

26. Drill through the marks made in the previous step and use the drill bit to connect the holes, making small mounting slots to allow for slight left to right adjustments.

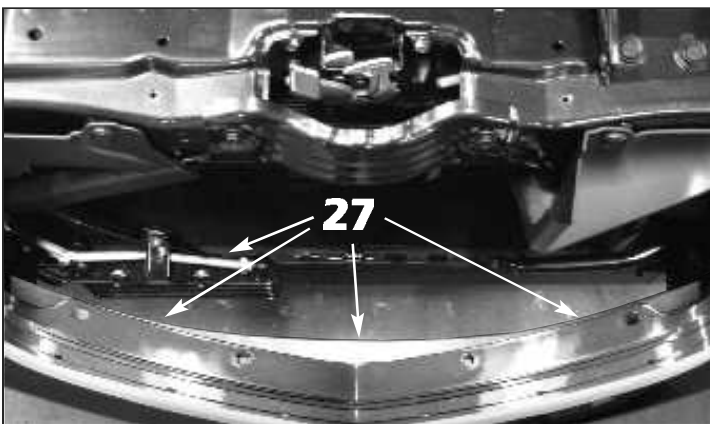

27. **For vehicles painted colors other than black or dark blue:** Use masking tape and tape even with the slots drilled in Step 26 and use a scotch brite pad to scuff the paint before applying black paint to everything inside the grille opening that would be visible through the mesh grille once it is installed.



28. Align the assembled grille onto the vehicle, making sure that after the lower mounting pins are aligned with the mounting slots, the edges of the upper painted factory grille section aligns with the bumper cover. You might have to push on the bumper cover from the back for them to fit together properly.

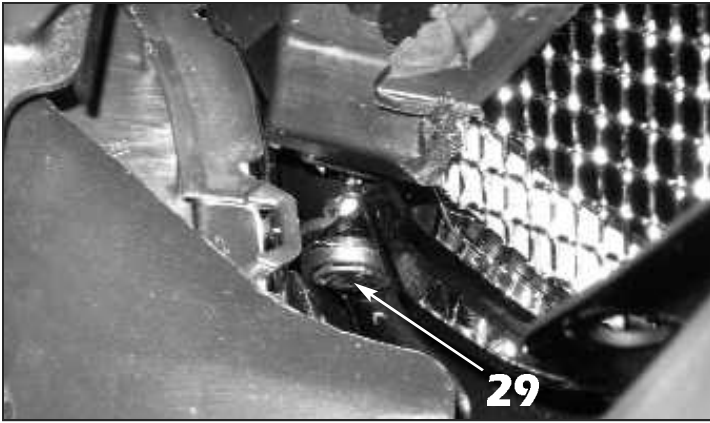

29. From underneath the vehicle, reinstall the outer factory push pins once the bumper cover sections are perfectly aligned. Use of extra long nosed pliers is recommended as clearance is at a premium.
 29a. Lower the vehicle and reinstall the upper 10mm hex bolts across the top of the grille (removed in step 4)

30. Remove the masking tape from the factory emblem and reinstall the radiator support panel cover (shown with optional brake duct covers - not included).

Fine Mesh Part #1402-0102-12		
Quantity:	Description:	Part Number:
1	Upper Grille Assembly	*****
1	Installation Hardware Kit	1402-1902-12
7	Small Black Plastic Washers	1999-0256-00
7	#8-32 ESNA Half Nuts	1999-0065-00
1	Upper Grille Upper Hole Template	1402-0067-12
1	Upper Grille Lower Hole Template	1402-0039-12
2	#8 x 1/2" Black truss Head Screws	3999-9035-00

Black Ice Fine Mesh Part #1402-B102-12		
Quantity:	Description:	Part Number:
1	Upper Grille Assembly	*****
1	Installation Hardware Kit	1402-1902-12
7	Small Black Plastic Washers	1999-0256-00
7	#8-32 ESNA Half Nuts	1999-0065-00
1	Upper Grille Upper Hole Template	1402-0039-12
1	Upper Grille Lower Hole Template	1402-0067-12
2	#8 x 1/2" Black truss Head Screws	3999-9035-00

E&G Classics Warranty Information:

E&G Classics, Inc. warrants its chrome parts and products to be free from defects in material, workmanship or finish for Thirty-Six (36) months from the date of shipment by E&G. This warranty is limited to the repair or replacement, at E&G Classics option, of the defective part or product. Full E&G Classics warranty information is available online @ www.egclassics.com. Just click on the product warranty icon.

For E&G Classic Product Returns:

Please contact the authorized E&G Classics Dealer where you purchased our product from in regards to any workmanship or warranty claims. All items returned to E&G Classics must have a return authorization number issued by us for inspection or a defective product and or warranty issue. All merchandise sent back to E&G Classics without proper paperwork or authorization will be rejected and returned.



