

IMPORTANT: PLEASE RETAIN THIS INSTRUCTION MANUAL FOR FUTURE REFERENCE

E&G Classics
2005-07 DODGE MAGNUM
"Heavy Metal" Mesh, "Dual Weave"
Mesh & QUARTER BY QUARTER "Z"
GRILLE INSTALLATION INSTRUCTIONS C20 G8R



-WILL NOT FIT SRT-8 MODELS-
 Due to the SRT-8 unique bumper cover.

"Z" Part # 1338-0185-05Q

Quantity	Description	Part No.
1 Set	"Quarter x Quarter" "Z" Inserts	Right 1338-018A-05Q Left 1338-018B-05Q
1	Hardware Kit (components listed below)	1338-0182-05Q
4	Top Retaining Brackets	1338-0057-05
4	Bottom Retaining Brackets	1338-0058-05
4	Black Nylon Retainers	5999-1952-00
4	1/8" x 3/8" Stainless Steel Rivets	1999-1929-00

"Heavy Metal" Part # 1338-0104-05

Quantity	Description	Part No.
1 Set	"Heavy Metal" Mesh Inserts	Right 1338-004A-05 Left 1338-004B-05
1	"Heavy Metal" Lower Mesh	1338-0041-05
1	Hardware Kit (components listed below)	1338-1902-05
4	Top Retaining Brackets	1338-0057-05
4	Bottom Retaining Brackets	1338-0058-05
4	Black Nylon Retainers	5999-1952-00
5	Lower Mesh Retaining Brackets	1338-0059-05
9	1/8" x 3/8" Stainless Steel Rivets	1999-1929-00

"Dual Weave" Part # 1338-0104-05D

Quantity	Description	Part No.
1 Set	"Dual Weave" Mesh Inserts	Right 1338-004A-05D Left 1338-004B-05D
1	"Dual Weave" Lower Mesh	1338-0041-05D
1	Hardware Kit (components listed below)	1338-1902-05
4	Top Retaining Brackets	1338-0057-05
4	Bottom Retaining Brackets	1338-0058-05
4	Black Nylon Retainers	5999-1952-00
5	Lower Mesh Retaining Brackets	1338-0059-05
9	1/8" x 3/8" Stainless Steel Rivets	1999-1929-00

IMPORTANT: The exposed edges of the stainless steel grille and mesh can be extremely sharp. Please handle with care.

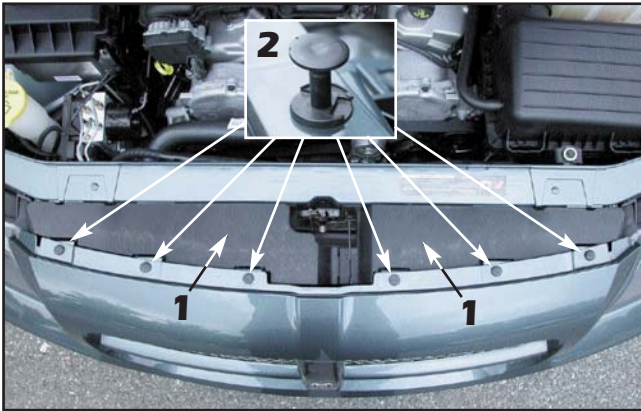

1. Open the hood and remove the upper core support covers by lifting them straight up to unclip.
2. Remove the six (6) factory push pins that retain the top of the bumper cover to the core support.



3. Pull the top of the bumper cover out for access to the factory grille inserts. Remove the upper factory clips from top of the grille inserts by prying them off with a small flat blade screw driver.

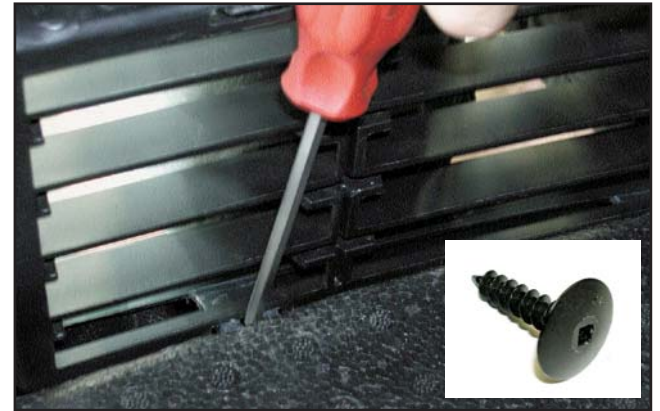

4. Use a phillips screw driver to remove the lower factory mounting screws and pry off the screw clips. There are two (2) large black plastic screws (see close-up) that retain the lower left and right sides of the factory grille inserts (one per insert). Remove the screws using a square drive bit (not shown).

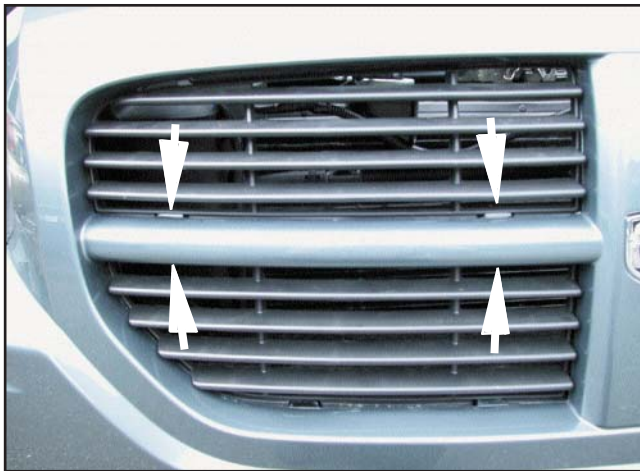

5. Squeeze the grille center bar mounting tabs together and push the insert inward to release it. Pull out on the bumper cover out far enough to extract the factory inserts. **Do not damage the styrofoam bumper cover!**



6. For vehicles painted other than black, use masking tape to cover the grille center bar and lower section. Paint the center and lower factory mounting tabs black to conceal them. Once the paint is dry, remove the masking tape.



7. Align the left and right mesh sections behind the factory grille openings. Be careful not to scratch the paint applied to the center and lower mounting tabs.



8. Install the black nylon retainers (push fasteners) into the lower mounting brackets. For the Heavy Metal Mesh and Quarter by Quarter "Z" grilles, install the push fastener into the offset hole closest to the front edge of the bracket. Align the brackets and install the push fasteners into the factory lower mounting holes.



9. Keeping the mesh grille tight against the opening, align the upper mounting brackets as shown and mark the mounting hole location onto the bumper cover.



10. Using a 1/8" drill bit, drill through the marks made in the previous step. **CAUTION! DO NOT LET THE DRILL CHUCK HIT THE STAINLESS STEEL MESH OR YOU COULD DAMAGE THE MESH!**

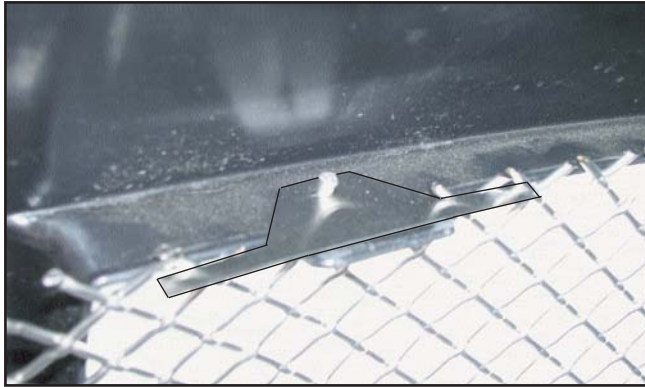

11. Install the upper mounting brackets as shown using the supplied stainless steel rivets. This photo shot from the inside showing the bracket attached to the top inside edge of the factory grille opening.

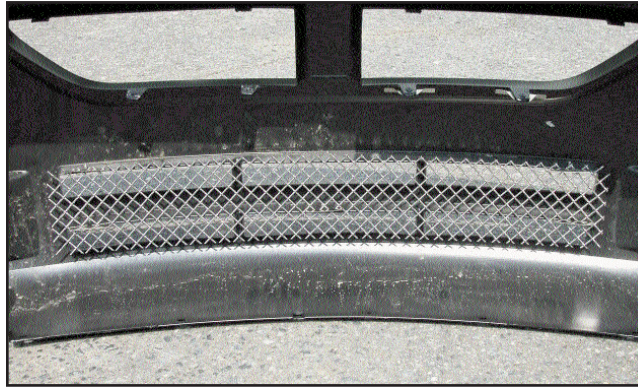

12. **Lower Grille Installation:** The following pictures were taken with the front end removed for photo clarity. You do not need to remove the bumper cover to install the lower grille.
13. Lower air deflector under the bumper cover for access to the lower grille opening. Align the mesh section into place, making sure the grille covers the entire opening.



14. Align and install the lower mesh mounting brackets using the same procedure outlined for the upper mesh sections. Two brackets will be used on each side (upper and lower positions as shown), with one bracket used at the lower center. Once the brackets are installed, reinstall the lower air deflector.



15. Finished installation.