

31054

TOYOTA 4RUNNER (EXCLUDES TRAIL EDITION)

GROSS LOAD CAPACITY WHEN USED AS A WEIGHT CARRYING HITCH: 3,500 LBS. TRAILER WEIGHT & 350 LBS. TONGUE WEIGHT.

GROSS LOAD CAPACITY WHEN USED AS A STRAIGHT LINE PULL: 9,000 LBS. MAX. LINE PULL.

*** DO NOT EXCEED VEHICLE MANUFACTURER'S RECOMMENDED TOWING CAPACITY. ***

Parts List			
ITEM	QTY	PART NUMBER	DESCRIPTION
1	2	3/8"	CONICAL TOOTHED WASHER
2	2	M10-1.25 x 35	HEX BOLT
3	2	1/2"	CONICAL TOOTHED WASHER
4	2	M12-1.25 x 35mm	HEX BOLT
5	2	5/8-11 x 1 3/4	CARRIAGE BOLT
6	2	5/8-11	HEX FLANGE NUT
7	2	CM-31054-SP	ROUND HOLE SPACER

TOOLS REQUIRED
RATCHET
10mm, 14mm, 17mm, 19mm & 15/16" SOCKETS
TORQUE WRENCH

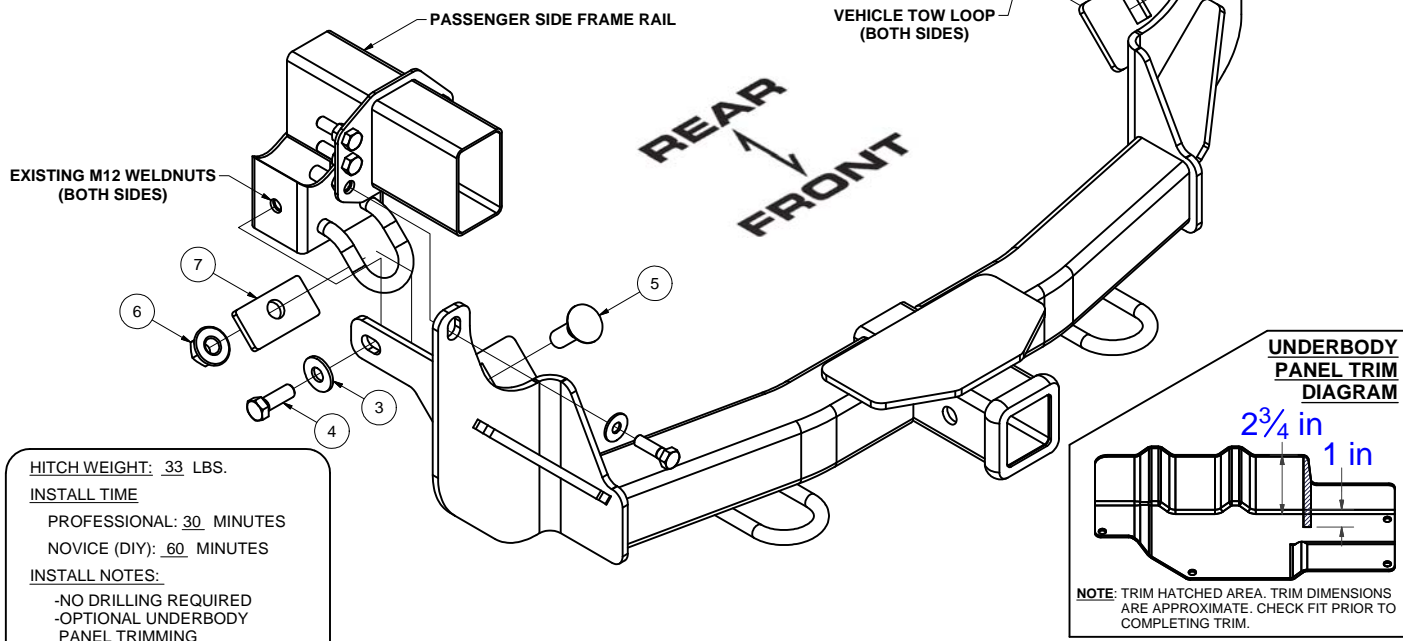
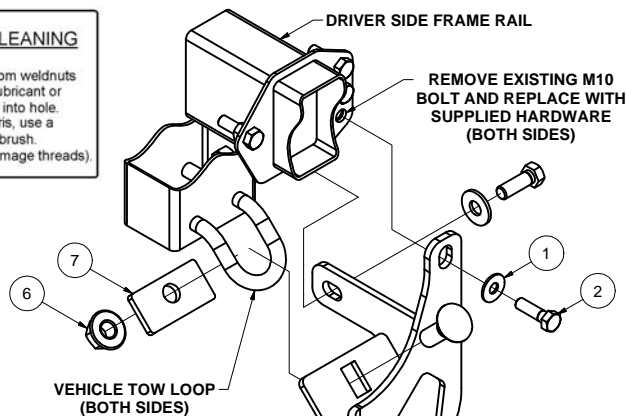
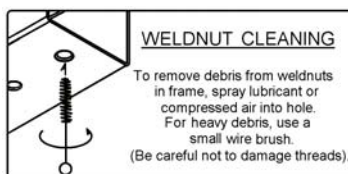

HITCH WEIGHT: 33 LBS.

INSTALL TIME

PROFESSIONAL: 30 MINUTES

NOVICE (DIY): 60 MINUTES

INSTALL NOTES:

- NO DRILLING REQUIRED
- OPTIONAL UNDERBODY PANEL TRIMMING

INSTALLATION STEPS

1. Remove driver and passenger side underbody panel by removing 5 fasteners from each. These will be returned to vehicle owner or trimmed and reinstalled in STEP 8.
2. Remove (1) hex bolt from the end of each frame rail (lowest outer bolt on each side) and return to vehicle owner. These will be replaced with the included M10 hardware.
3. Lift hitch into position, locating the vehicle tow loops under the hitch mounting plates.
4. Loosely insert the included M10 hex bolts with 3/8" conical tooth washers into weldnuts which bolts were removed from in STEP 2.
5. Loosely insert M12 bolts with 1/2" conical tooth washers into existing weldnuts on the outsides of frame rails.
6. Insert 5/8" carriage bolts through the hitch mounting plates and tow loops. Secure hitch to tow loops by attaching supplied spacers and 5/8" flange nuts to carriage bolts.
7. Torque all M10 fasteners to 37 ft-lbs, all M12 fasteners to 65 ft-lbs and all 5/8" fasteners to 150 lb-ft.
8. If trimming option is selected, trim underbody panels removed in STEP 1 and reinstall. See UNDERBODY PANEL TRIM DIAGRAM above.

PERIODICALLY CHECK THIS RECEIVER HITCH TO ENSURE THAT ALL FASTENERS ARE TIGHT AND THAT ALL STRUCTURAL COMPONENTS ARE SOUND.

Curt Manufacturing Inc., warrants this product to be free of defects in material and/or workmanship at the time of retail purchase by the original purchaser. If the product is found to be defective, Curt Manufacturing Inc., may repair or replace the product, at their option, when the product is returned, prepaid, with proof of purchase. Alteration to, misuse of, or improper installation of this product voids the warranty. Curt Manufacturing Inc.'s liability is limited to repair or replacement of products found to be defective, and specifically excludes liability for incidental or consequential loss or damage.

*****DO NOT EXCEED VEHICLE MANUFACTURER'S RECOMMENDED TOWING CAPACITY ***.**

FRONT MOUNTED ACCESSORIES

1) Do not exceed front axle Gross Weight Rating (GAWR). Consult owners manual or specification plate located on driver's door frame. Measure gross front axle weight by placing front wheels of loaded vehicle on a scale.

WARNING: Exceeding GAWR may overload the front axle and/or suspension. This could result in **accident, property damage and personal injury.**

- 2) Reposition front mounted license plate if obstructed.
- 3) Do not obstruct vehicle lights.
- 4) Allow free air flow into grille opening.
- 5) Rear wheel traction may be reduced. This could effect handling. Reduce speed and drive with caution.
- 6) Accessories extend front of vehicle. This may reduce approach angle. Use caution when parking and maneuvering.
- 7) Do not obstruct driver view.

VEHICLE RECOVERY AND WINCHING TIPS

1) Use OEM tow hooks, recovery eyes or a clevis mount for attachment of a tow strap or winch cable.

WARNING: NEVER use a ball and/or ball mount as an anchor point for tow strap or winch cable. Severe personal injury or death could result.

- 2) Observe winch manufacturer's recommendations, cautions and warnings.
- 3) Attach return cable to tow hook or recovery eye when using a snatch block (See figure 1).

CAUTION: Do not attach return cable to winch mount. This may overload winch mount and/or front mounted receiver.

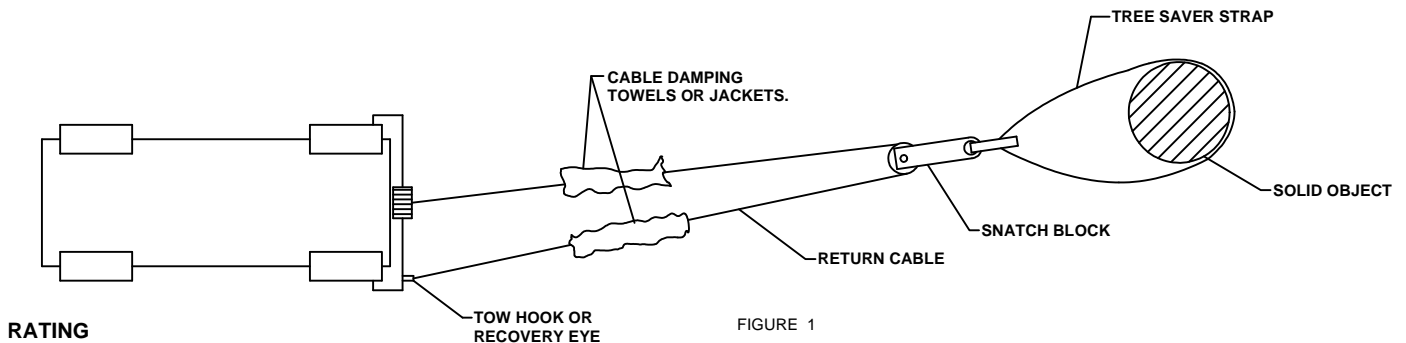

For **Maximum** line pull rating, winch cable must not exceed:

- 15 degree angle up or down from horizontal (See Figure 2).
- 45 degree angle left or right from straight ahead (See Figure 3).

CAUTION: Exceeding the maximum line pull rating may over load winch, winch mount, and/or front mounted receiver.

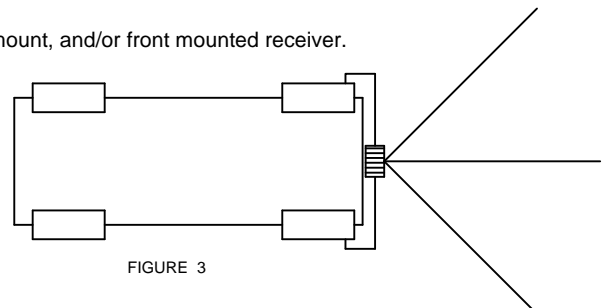
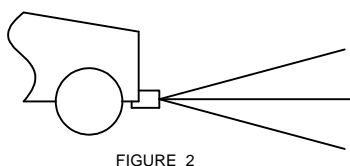

YEARS: 2010 - PRESENT

MAKE: TOYOTA

MODEL: 4RUNNER (EXCLUDES TRAIL EDITION)

STYLE: SUV

WARNING: NEVER EXCEED YOUR VEHICLE MANUFACTURER'S RECOMMENDED TOWING CAPACITY





WEIGHT CARRYING:
 TRAILER WEIGHT: 3,500 LBS.
 TONGUE WEIGHT: 350 LBS.

GROSS LOAD CAPACITY WHEN USED AS A STRAIGHT LINE PULL:
 9,000 LBS MAX.

INSTALLATION TIME: 30 MIN.

THE INSTALL TIME LISTED IS FOR PROFESSIONAL INSTALLERS. IF YOU ARE HESITANT TO UNDERTAKE THIS TASK ON YOUR OWN, CONTACT AN AUTHORIZED CURT INSTALLER FOR ADDITIONAL ASSISTANCE.





INSTALLATION REQUIRES:

 RATCHET	 10mm 14mm 17mm 19mm 15/16" SOCKET	 TORQUE WRENCH
 SAFETY GLASSES		

INSTALLATION TIPS:

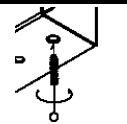
- BEFORE YOU BEGIN INSTALLATION, READ ALL INSTRUCTIONS THOROUGHLY.
- TO EASE INSTALLATION, 2 PEOPLE MAY BE REQUIRED.
- USING PROPER TOOLS WILL GREATLY IMPROVE THE QUALITY OF THE INSTALL AND REDUCE THE TIME REQUIRED.

LEVEL OF DIFFICULTY: MODERATE

EASY	MODERATE	CHALLENGING
	WELDNUT CLEANING MAY BE REQUIRED	
	REMOVE DRIVER AND PASSENGER UNDERBODY PANEL	
	OPTIONAL UNDERBODY PANEL TRIMMING	
	NO DRILLING REQUIRED	

VEHICLE PHOTO:



REPRESENTATIVE PHOTO

HITCH ILLUSTRATION:

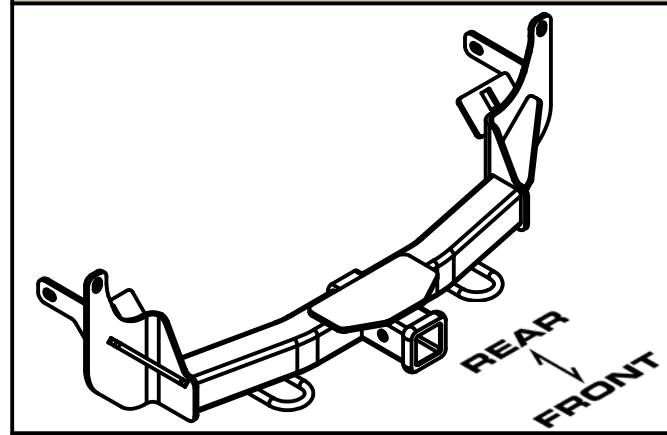

MAKE SURE YOUR HITCH MATCHES

PERIODICALLY CHECK THIS RECEIVER HITCH TO ENSURE ALL FASTENERS ARE TIGHT AND ALL STRUCTURAL COMPONENTS ARE SOUND

CURT Manufacturing Inc. warrants this product to be free of defects in material and/or workmanship at the time of retail purchase by the original purchaser. If the product is found to be defective, Curt Manufacturing Inc. may repair or replace the product at their option, when the product is returned, prepaid, with proof of purchase. Alteration to, misuse of, or improper installation of this product voids the warranty. Curt Manufacturing Inc.'s liability is limited to repair or replacement of products found to be defective, and specifically excludes liability for incidental or consequential loss or damage.

INSTALLATION WALKTHROUGH:

Parts List			
ITEM	QTY	PART NUMBER	DESCRIPTION
1	2	3/8"	CONICAL TOOTHED WASHER
2	2	M10-1.25 x 35	HEX BOLT
3	2	1/2"	CONICAL TOOTHED WASHER
4	2	M12-1.25 x 35mm	HEX BOLT
5	2	5/8-11 x 1 3/4	CARRIAGE BOLT
6	2	5/8-11	HEX FLANGE NUT
7	2	CM-31054-SP	ROUND HOLE SPACER

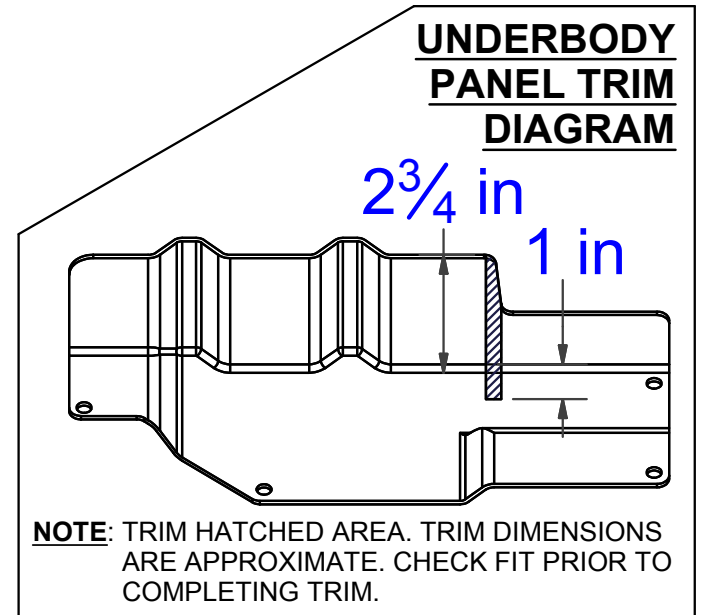
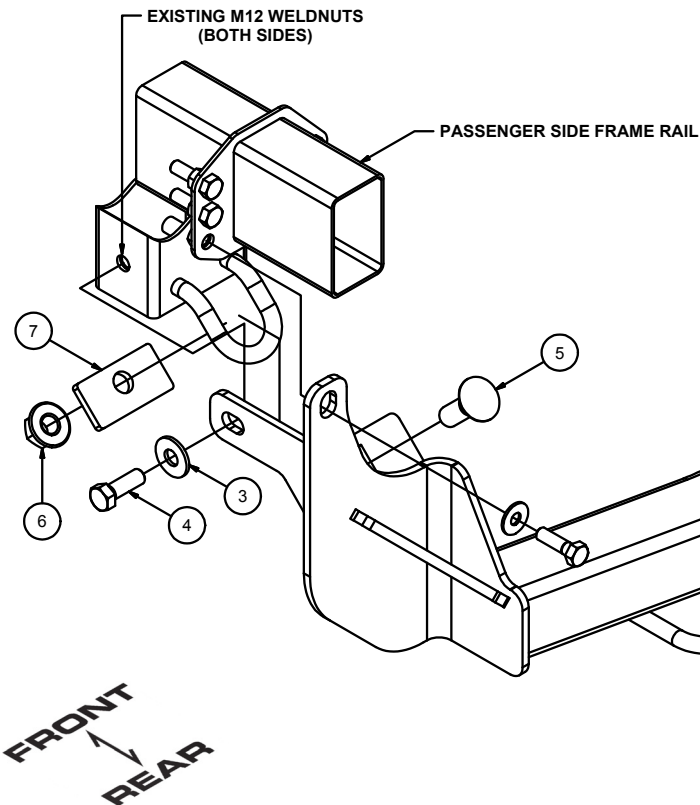
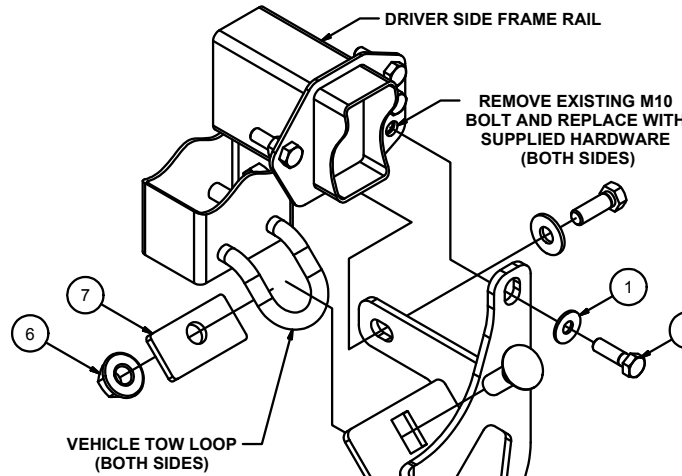
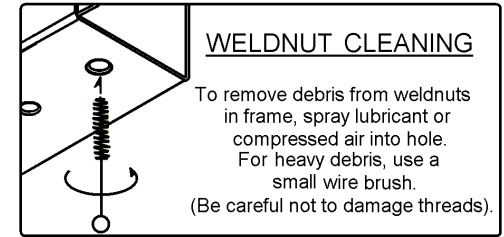

INSTALLATION WALKTHROUGH:

1. Remove driver and passenger side underbody panel by removing 5 fasteners from each. These will be returned to vehicle owner or trimmed and reinstalled in STEP 8.

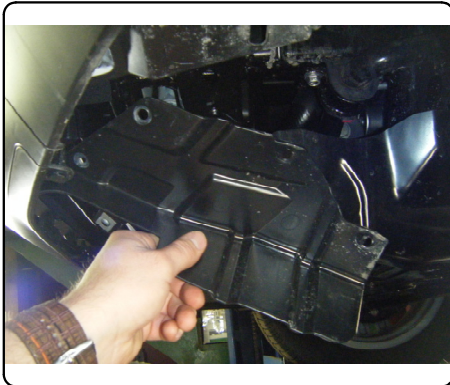

2. Remove (1) hex bolt from the end of each frame rail (lowest outer bolt on each side) and return to vehicle owner. These will be replaced with the included M10 hardware.

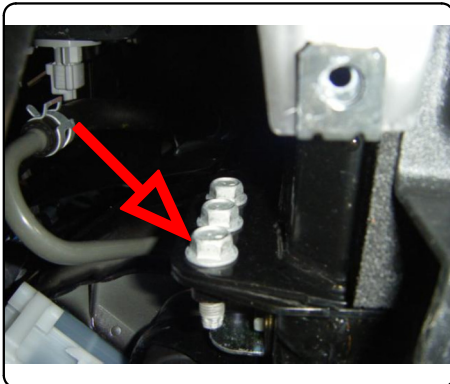

3. Lift hitch into position, locating the vehicle tow loops under the hitch mounting plates.

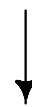

4. Loosely insert the included M10 hex bolts with 3/8" conical tooth washers into weldnuts which bolts were removed from in STEP 2.

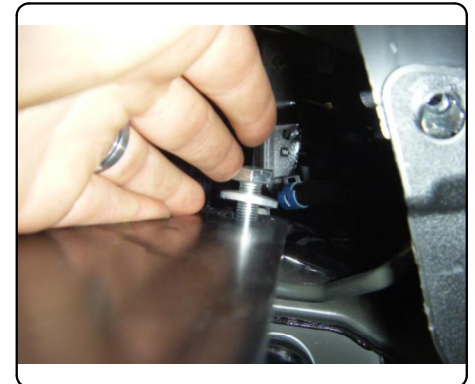
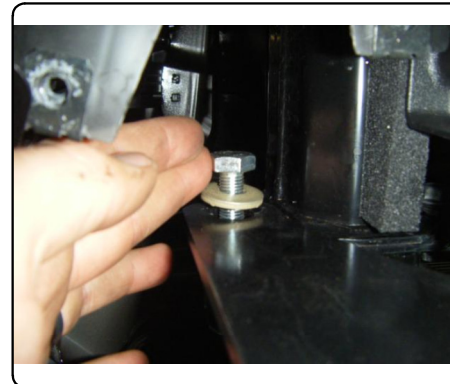

INSTALLATION WALKTHROUGH:

5. Loosely insert M12 bolts with 1/2" conical tooth washers into existing weldnuts on the outsides of frame rails.



6. Insert 5/8" carriage bolts through the hitch mounting plates and tow loops. Secure hitch to tow loops by attaching supplied spacers and 5/8" flange nuts to carriage bolts.

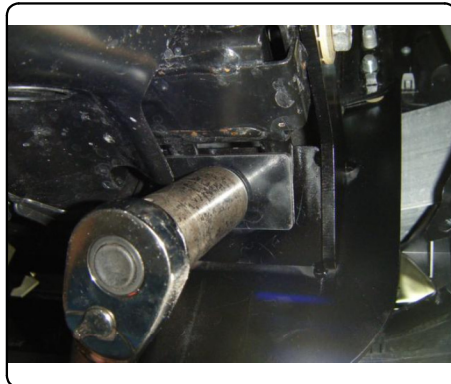

7. Torque all M10 fasteners to 37 ft-lbs, all M12 fasteners to 65 ft-lbs and all 5/8" fasteners to 150 lb-ft.

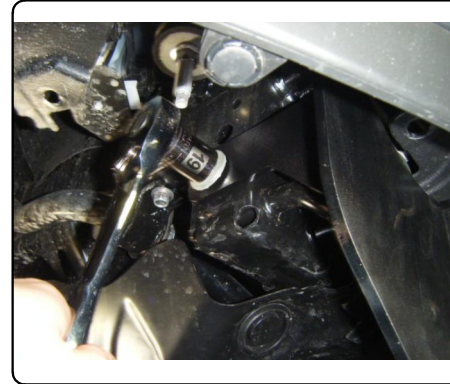

8. If trimming option is selected, trim underbody panels removed in STEP 1 and reinstall. See UNDERBODY PANEL TRIM DIAGRAM on page 2 and photo below.

