

# Installation Instructions

## Powerglide Pro Lever

### Part No. 70465

©2002 B&M Racing & Performance Products

The B&M Pro Lever is designed for use on aluminum Powerglide transmissions without the throttle lever and shaft. It is a two piece lever rather than the usual one piece lever. It has four holes for the cable swivel so that it can be used with B&M, Turbo Action or Hurst shifters.

The B&M Pro Lever must be used with either a manual valve body or with a trans brake. The lever can not be used with an automatic valve body since there is no provision for a throttle linkage lever.

The shaft portion of the lever is installed in the transmission in the normal Powerglide manner. The lever is then put over the end of the shaft with the lever pointing down (for a standard installation). The cable bracket for your particular shifter is bolted on, the cable is installed in the bracket and the swivel is screwed onto the cable. The swivel is then inserted into

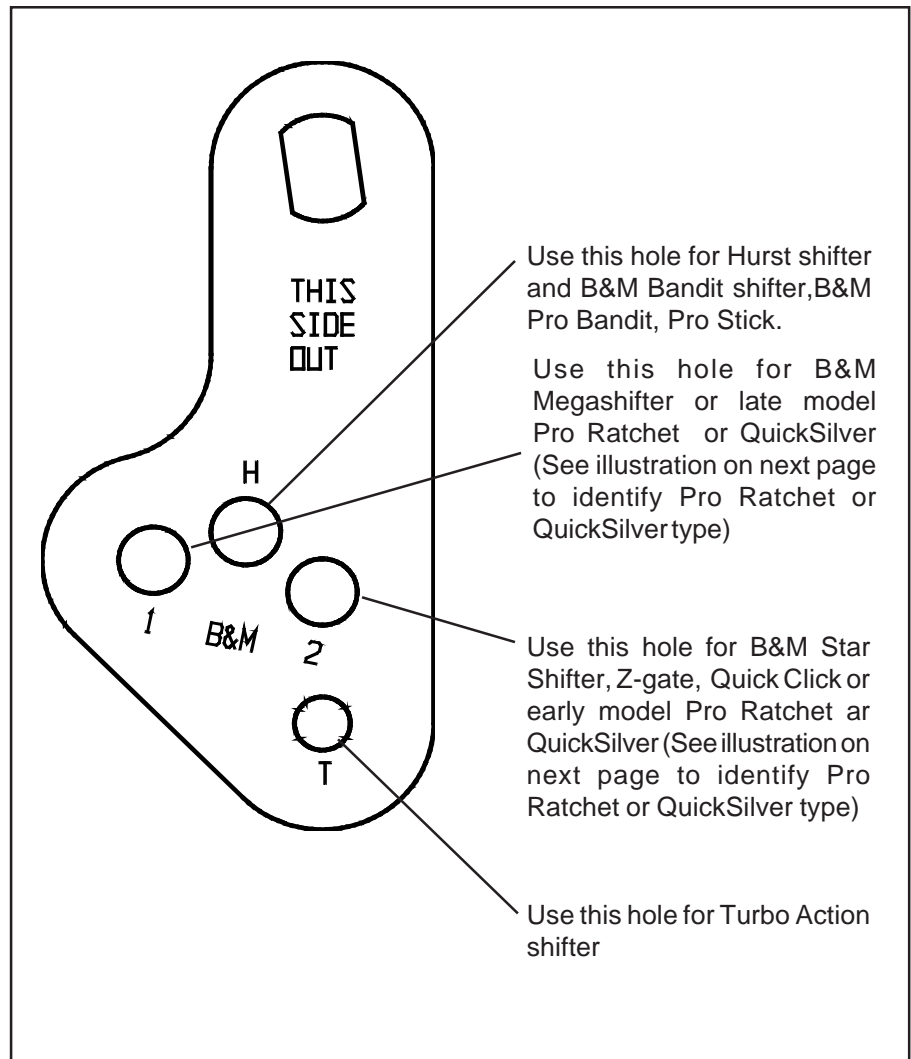

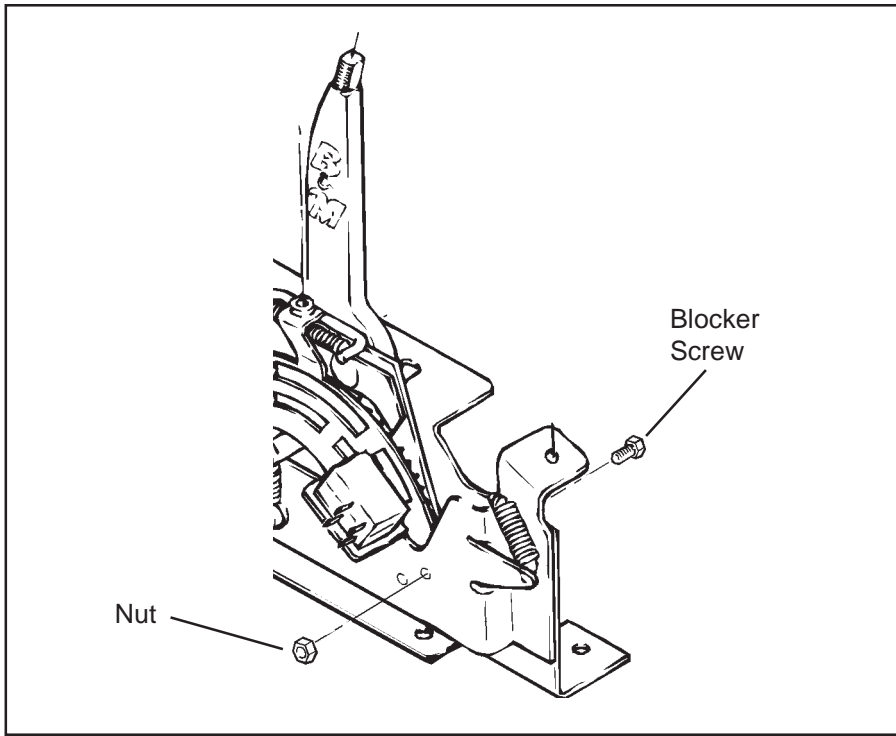

Late model Pro Ratchet or QuockSilver shifter

the correct hole on the lever as shown in the illustration on the first page. With B&M Shifters it is very important that the correct hole be used for the swivel, otherwise the shifter will not work correctly.

If the cable comes from the front (usually a rear engine car) the lever is installed pointing upwards. You will have to make a cable bracket for this installation.

There are two versions of the

B&M Pro Ratchet and QuickSilver shifters and they use different mounting holes for the cable swivel. If the swivel is put in the wrong hole, the shifter cannot be correctly adjusted. Early models of these two shifters use the hole marked "2" and late model shifter use the hole marked "1". The late models of these two shifters started production in late 1998. The late model shifters can be identified by the blocker screw and nut at the back of the shifter to limit the travel of the shifter for use on 3 speed or Powerglide transmissions. If your shifter has two holes punched in each of the side plates and has a blocker screw and nut installed in one of the holes it is a late model Pro Ratchet or QuickSilver and should use the hole in the lever marked "1". Otherwise use the hole marked "2". The illustration on this page shows the location of the blocker screw.