



Bestop

Replace - A - Top Installation Instructions

For: Chevrolet Tracker
1999 and newer

Part Number: 51366

***Do Not install this product
on any vehicle other than the
one listed above.***

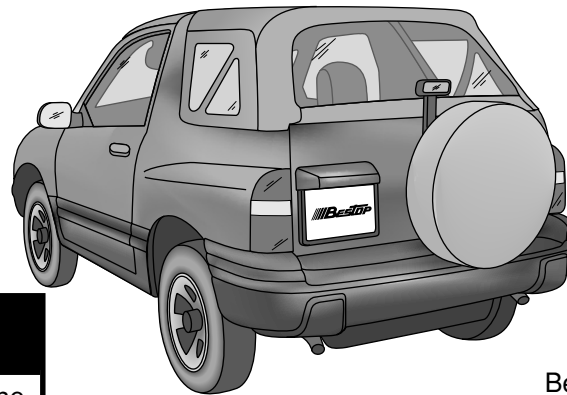

Installation Tips

Before you begin installing this top assembly, read all instructions thoroughly. After completing the installation, keep these instructions for further reference. Below are a few tips to make this installation easier.

For a smooth fit:

For ease in installation, the top should be installed at temperatures above 72° F. Below this temperature, the top may contract an inch or more, making it difficult to fit to the vehicle.

It is normal for a top to contract and wrinkle when stored in the shipping carton. Within a few days after the installation, the top will relax and the wrinkles will disappear.



WARNING

This product is designed to enhance the appearance of the vehicle and to shield the occupants from ordinary weather conditions. Do not rely in any way on the components of this product to contain occupants within the vehicle, or to protect against injury or death in the event of an accident. This top will not protect the occupants from falling objects. Never operate vehicle in excess of manufacturer's specifications.

WEAR SEAT BELTS AT ALL TIMES

Read and follow, precisely, all installation instructions provided when installing top. Failure to do so may result in a poor fitting top and could place occupants of the vehicle in a potentially dangerous situation.

Parts List

Front Deck	Qty - 1
Rear Deck	Qty - 1
Quarter Window, Rt.	Qty - 1
Quarter Window, Lt.	Qty - 1
Rear Window	Qty - 1

Tools Needed

3mm Allen Wrench



Caution

Safety glasses should be worn at all times while installing this product.

Top Installation

Step One

Remove the old top. Set aside the two 7/64 Allen Bolts in the front center pillar retainer aside to be used in installing the Replacement Top (see Step Three) and the Rear Window Retainer Bar (see Step Eleven).

Step Two

Orient the Front Deck with the snaps toward the front of the vehicle and the vinyl side up. Turn the deck over and lay it vinyl side down on the center pillar of the vehicle with the plastic retainer strip toward the front. Locate the center notch in the strip and align it with the arrow marking the center of the retainer along the front edge of the center pillar. Slip the plastic strip into the channel on the retainer.

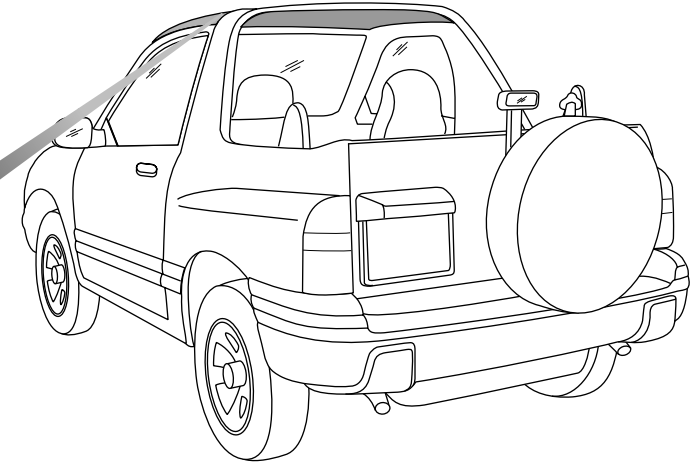
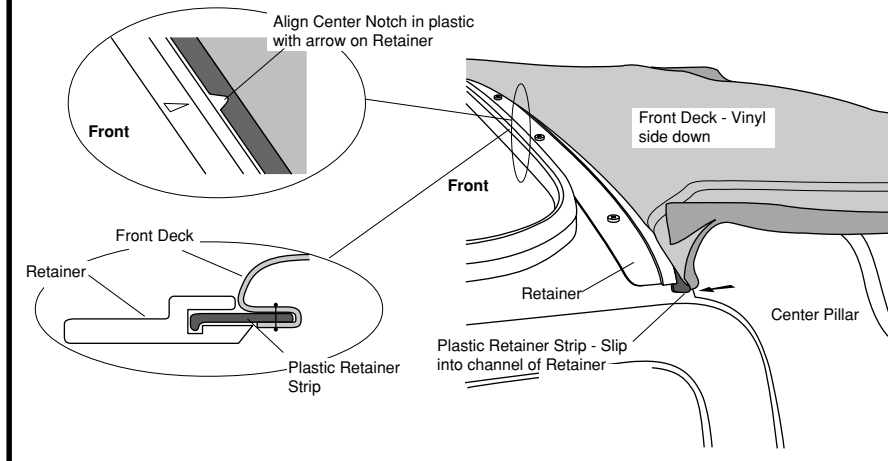

Step Three

Reinstall the 3mm Allen Bolt in the slot on each end of the Retainer on the center pillar.

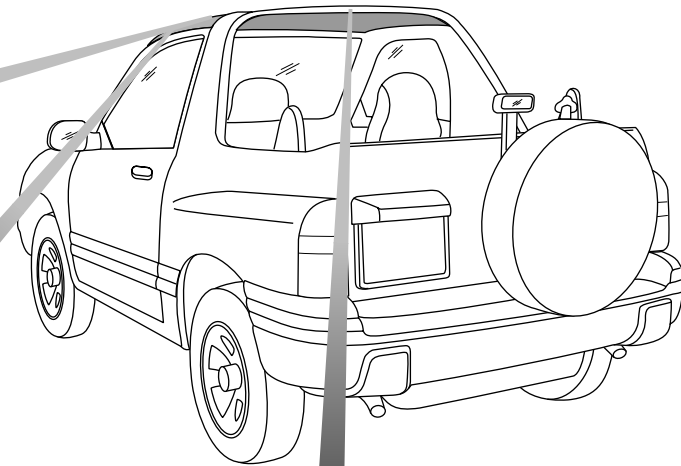
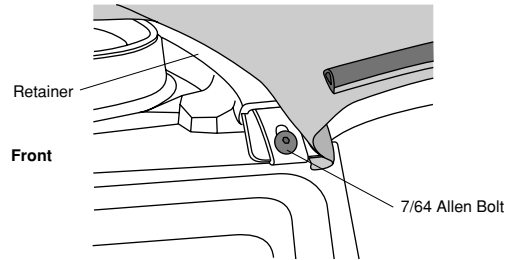

Step Four

Raise the Windshield Header Assembly and slip the front of the Front Deck over the front edge of the header, working the pockets in the top over the corners of the header. Snap the seven snaps on the top to the snaps on the header. The snaps on the header slide to align with the snaps on the top.

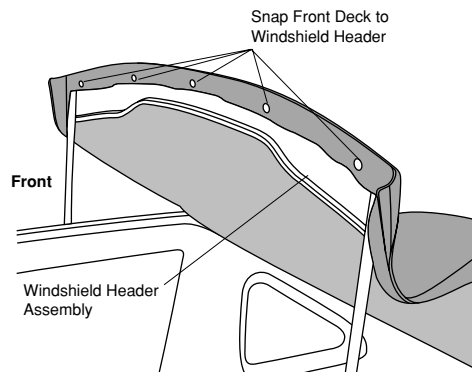

Step Five

Locate the flap with two tabs sewn inside the rear of the Front Deck. Snap the tabs on each side of the Dome Light.

The web strap sewn to the flap is used to tie the fabric out of the way when the Header is open. To use the strap, slip the end of the strap through the slot in the header and fasten the loop sewn to the end of the strap to the hook on the strap.

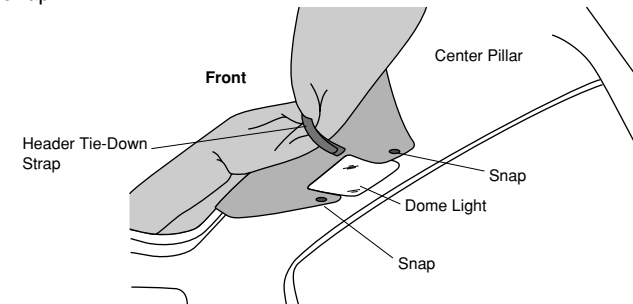

Step Six

Close the header to the windshield. Hook the latches to the header and close them to secure the front of the deck to the windshield.

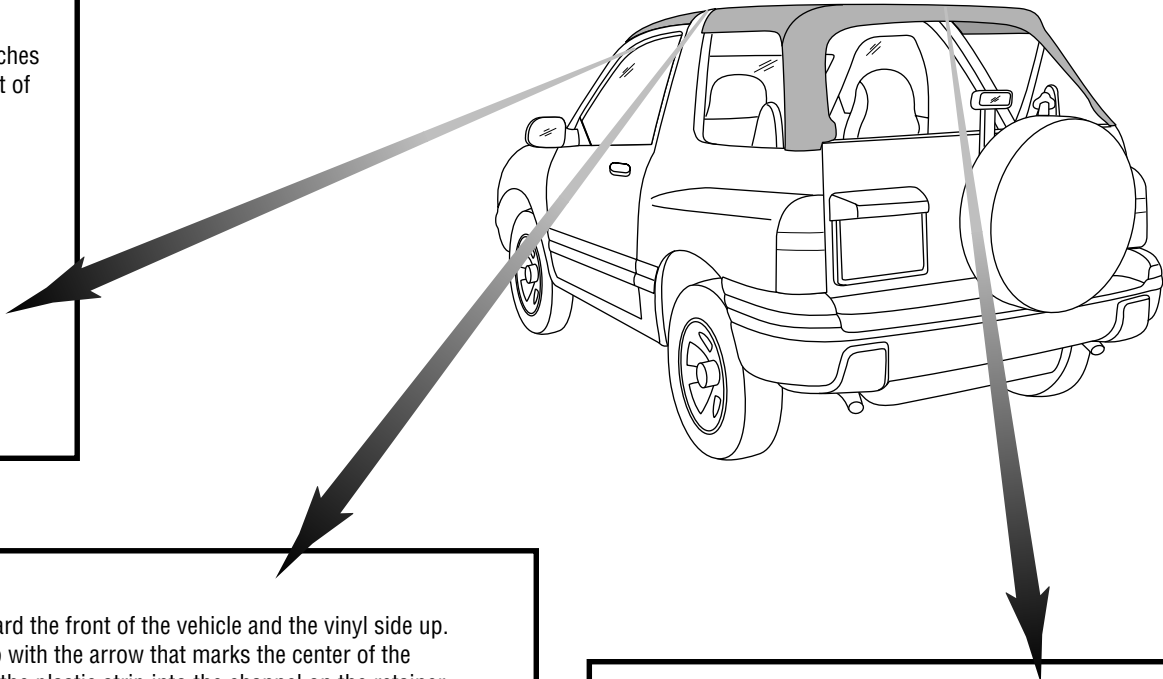
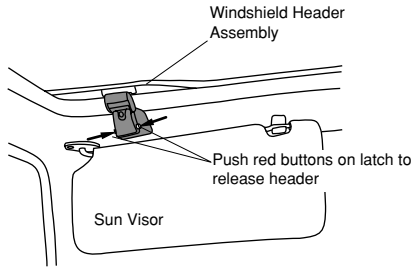

Step Seven

Orient the Rear Deck with the plastic strip toward the front of the vehicle and the vinyl side up. Align the notch in the center of the plastic strip with the arrow that marks the center of the retainer along the rear of the center pillar. Slip the plastic strip into the channel on the retainer.

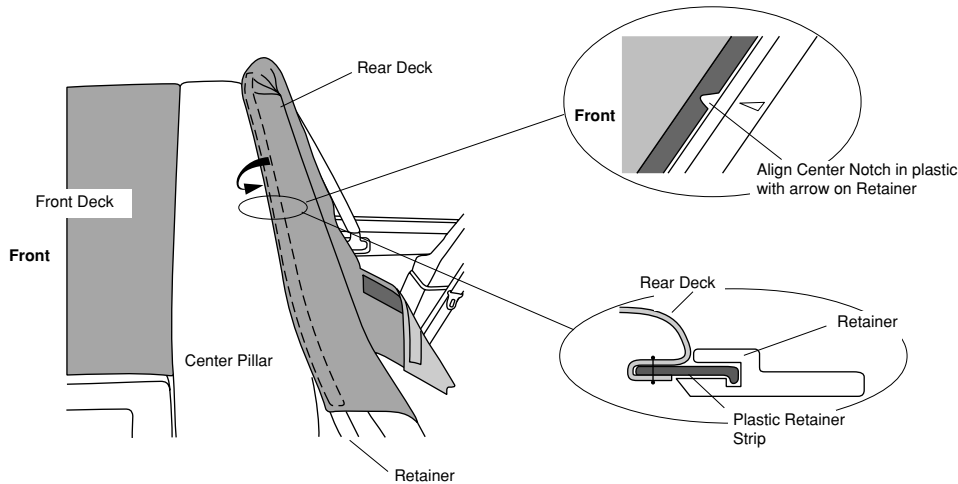

Step Eight

Raise the rear bow and slip it into the rear corners of the Rear Deck. Wrap the snap tabs sewn into the top above the rear window opening around the bow and snap them to the bow.

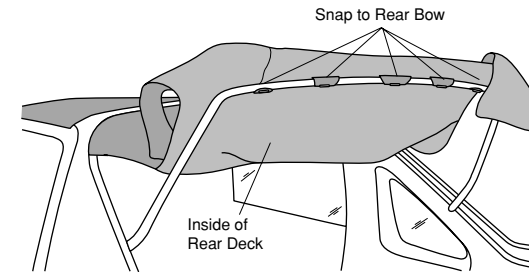

To Release the Bow Assembly

To release the bow assembly, push the button on the bow release and pull the latch away from the bow.

To lock the bows into the upright position, close the latch against the bow until it locks into place.

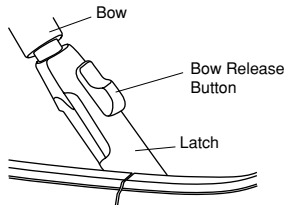

Bow in Upright Position

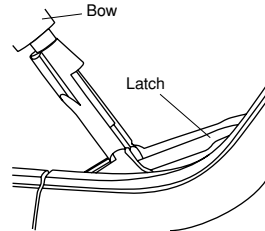

Bow in Released Position

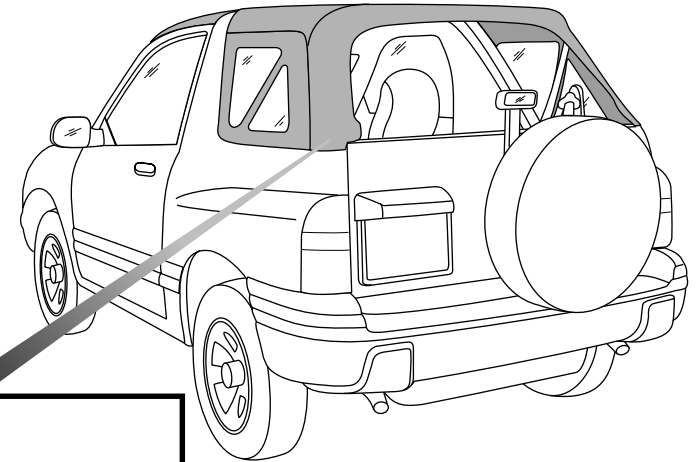

Step Nine

Make sure that the rear bow assembly is released and that the bow is in the released position.

Pull the rear legs of the deck down to the rear corners of the vehicle and locate the plastic strip sewn to the bottom of each leg. Slip the plastic into the corner retainer on the vehicle. The rear edge of the plastic should butt up against the stop on the retainer next to the tailgate opening and the front edge of the plastic should rest next to a pin in the retainer. If your vehicle does not have a pin in the retainer next to the front edge of the plastic strip, hook the plastic clip in the top over the edge of the retainer above the tailgate opening.

Lock the bows into the upright position.

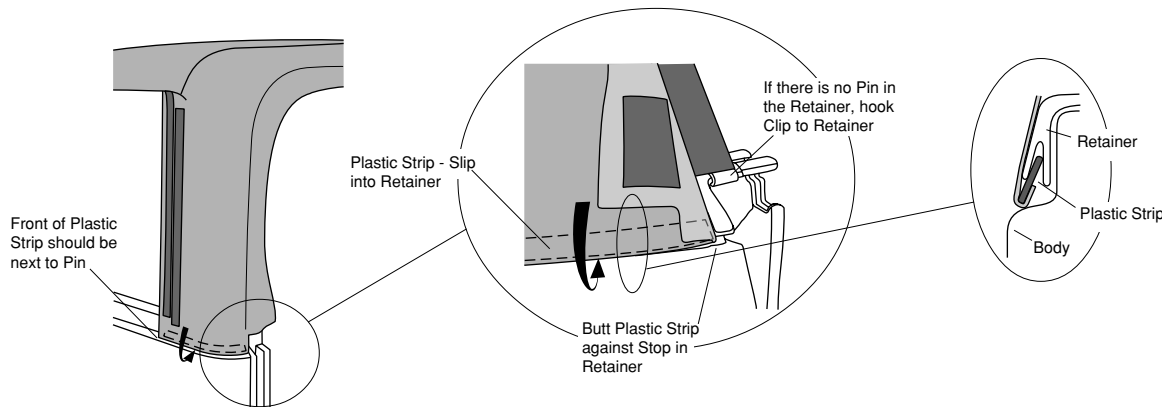

Step Ten

Orient the Quarter Windows with the zipper toward the top and rear of the panel. Start the zipper at the top front corner and close it a few inches. Slip the plastic strip along the front and bottom of the panel into the retainer on the vehicle. Close the zipper to the rear corner of the panel. Make sure that the panel is seated into the retainer for a smooth fit. Tuck the top edge of the panel under the deck and fasten the hook and loop strips along the top and rear of the panel.

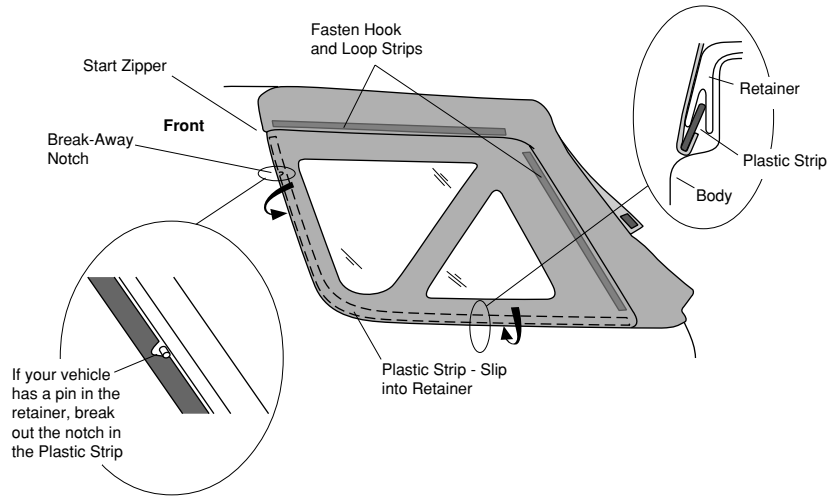

Note: The plastic strip along the front of the Quarter Window has a break-away notch. If your vehicle has a pin in the retainer that keeps the retainer from rolling into the channel, break out the notch and center it over the pin when setting the plastic strip into the retainer.

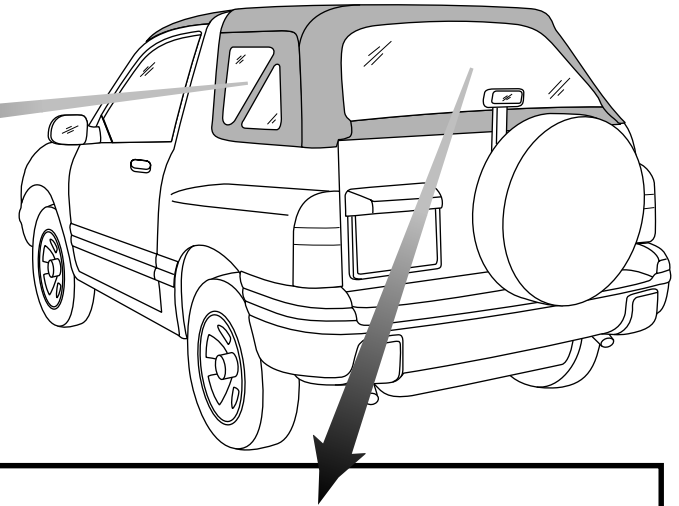

Step Eleven

Open the tailgate and orient the Rear Window with the zipper toward the top and the vinyl side out. Start the zipper on the passenger side of the vehicle and close it halfway to the other side. Slide the round channel in the Rear Window Retainer Bar onto the bottom edge of the window. Press the bar onto the ledge of the Rear Corner Retainers on each side of the tailgate opening. Close the zipper. Locate the loop flaps sewn on each side of the Rear Window, fold them over the ends of the zipper and fasten them to the hook sewn inside the top. Close the tailgate.

Detail of Rear Window Retainer Bar

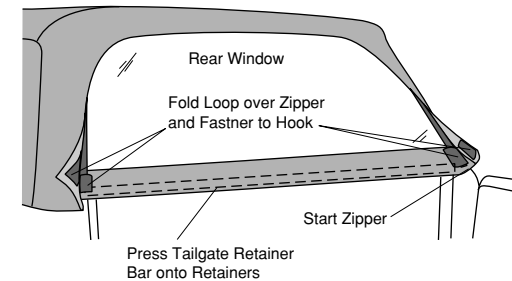
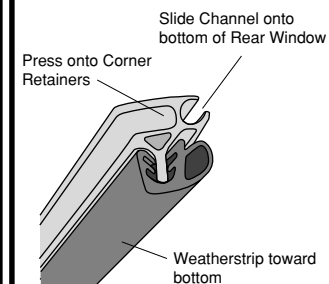

Care and Maintenance of your Bestop Top

Your top is made of the finest materials available. To keep it looking new and for the maximum possible wear, it will need periodic cleaning and maintenance.

Washing: The top fabric should be washed often using soap, warm water and a soft bristle brush. Rinse with clear water to remove all traces of soap.

Windows: Keep windows clean to avoid scratching. DO NOT use a brush on the windows! Wash with a watersoaked cloth or sponge and a mild dishwashing detergent. NEVER WIPE THE WINDOWS WHEN THEY ARE DRY. Be careful when cleaning snow or frost from the vinyl windows since they are easily scratched and may crack at low temperatures. DO NOT roll the sides or rear window in cold weather. The windows become stiff and will crack.

Zippers: Keeping the zipper cleaned and lubricated with a silicone lubricant will help prevent damage and keep the zippers in a smooth working condition. If a zipper opens behind the slider, the slider may have been spread apart. This problem can usually be repaired by using an ordinary pair of pliers to bring the sides back into parallel. Return slider to the end of the zipper in the normal Open position. Squeeze lightly at first and test the zipper. If the zipper continues to remain open squeeze more firmly with the pliers and try the zipper again. Repeat this procedure until the zipper operates correctly.

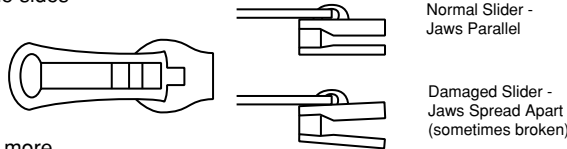

Water: Seeping through at the seams may be stopped by applying 3-M Scotchgard® on the inside of the seams. Rips in the fabric may be repaired with Bondex® iron on patches. Iron the patches to the Inside of the top, carefully following the Bondex® instructions.

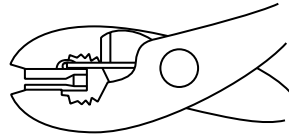

Snaps: Keep snaps cleaned and lubricated with silicone to help prevent snaps from sticking to the studs. If a snap does become stuck to a stud, use a screwdriver and GENTLY pry apart to prevent permanent damage to the snap or the top fabric.