

# USER GUIDE AND INSTALLATION MANUAL KEYLESS ENTRY SYSTEM

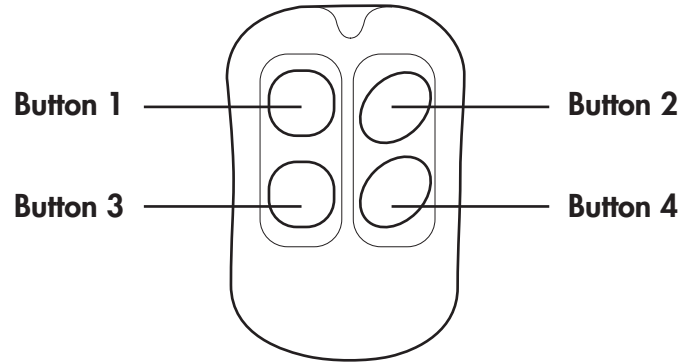

## KL550 5 channel system

Button	Function	Condition
1	Enable starter/ignition kill and lock door 1st channel output	Starter/ignition kill disabled
2	Disable starter/ignition kill and unlock door 2nd channel output	Starter/ignition kill enabled
3	3rd channel output	Anytime
4	4th channel output	Anytime
1+3	5th channel output	Anytime



Preprogrammed Remote Transmitter

## INTRODUCTION

### ABOUT YOUR DOOR LOCKING SYSTEM

All power door locking systems have switches to activate doors. These switches are usually located on the door or center console. In some cases (BMW) the switch is located inside the drivers door actuator. Your door lock switch will have at least 2 trigger wires, one for locking your doors called the LOCK wire, and one for unlocking your doors called the UNLOCK wire. Your switch will also have one sender wire. When the sender wire connects to a trigger wire your doors will activate (unlock or lock).

When you push your door lock switch to "lock", your sender wire connects with your lock wire, to lock your doors. When you push your door lock switch to "unlock", your sender wire connects with your unlock wire, to unlock your doors.

Negative and Positive triggers are the two main types of door locking systems. On a negative trigger system your sender wire is "-". When you give a "-" to the trigger wires they will activate your doors (unlock or lock). On a positive trigger system your sender wire is "+". When you give a "+" to the trigger wires they will activate your doors (unlock or lock).

### LOCATION OF WIRES

1. Open the Door
2. Locate the Power Door Lock Switch.
3. Remove the switch from the door so that you can gain access to the wires

Note: If your car has no door lock switch then you have central locking (BMW). Central locking systems have the unlock, lock, and sender wires built in to the drivers side door actuator (inside door). There is no need to remove the driver's door panel since these wires travel from the driver's door, through the door jam, to the interior of your vehicle. Test all wires coming from the drivers door for the lock, unlock, and sender wires. Wire according to the proper system.

## USER GUIDE

### CODE LEARNING

- a. Turn key to ON position, press valet button for 3 seconds. The parking lights will flash once to indicate code learning mode. Press any button in order to learn the desired remote. The parking lights and LED will flash once for confirmation, after each remote transmitter is learned. Up to 4 remote transmitters can be learned at this time.
- b. Turn key to OFF position or wait for 5 seconds and system will exit code learning.

### REMOTE DOOR LOCKING

- a. Press button 1. The parking lights will flash once. The starter/ignition kill circuit will be enabled and the lock output will pulse for 1 second or until button 1 is released.
- b. LED will begin flashing slowly.

### REMOTE DOOR UNLOCKING

- a. Press button 2. The parking lights will flash twice. The starter/ignition kill circuit will be disabled and the unlock output will pulse for 1 second or until button 2 is released.
- b. LED will be off.

### CH1 OUTPUT

Press button 1 to output channel 1 continuously until button 1 is released.

### CH2 OUTPUT

Press button 2 to output channel 2 continuously until button 2 is released.

### CH3 OUTPUT

Press button 3 to output channel 3 continuously until button 3 is released.

### CH4 OUTPUT

Press button 4 to output channel 4 continuously until button 4 is released.

### CH5 OUTPUT

Press buttons 1+3 to output channel 5 continuously until buttons 1+3 are released.

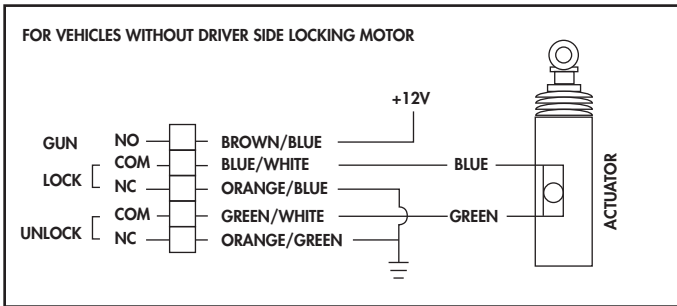

This system has a switch instead of an actuator in the drivers door. You will need to mount an actuator (GT series) in the drivers door to control your locks. Wiring diagram comes with actuator (GT series)

1. Install the fuse on the red wire then connect the BROWN/BLUE, and RED wires to a constant 12 volts.
2. From the keyless entry unit connect the ORANGE/BLUE, ORANGE/GREEN, and BLACK wires to metal ground.
3. Mount the actuator, and connect the BLUE/WHITE and GREEN/WHITE wires to the actuators green and blue wires.

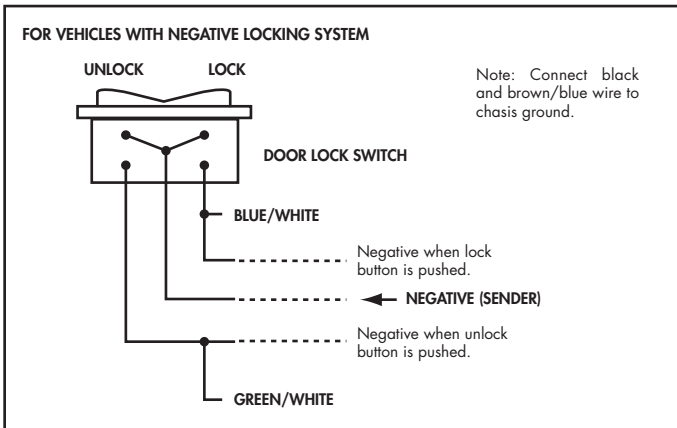

Testing (w/an airbag safe digital volt-ohm meter)

Connect the testlight wire to a ground (-), then probe all wires from your door lock switch to determine the lock, unlock, and sender wires.

1. If you come to a wire that LOCKS your doors when probed (-), then you have found the lock wire. Connect the BLUE/WHITE wire from the keyless entry unit to this wire.
2. If you come to a wire that UNLOCKS your doors when probed (-), then you have found the unlock wire. Connect the GREEN/WHITE wire from the keyless entry unit to this wire.
3. From the keyless entry unit connect the BROWN/BLUE wire to your sender wire. This wire will be a constant "+".
4. Install the fuse on the red wire then connect the RED wire to a constant 12 volts (+), and the BLACK wire to a body ground.

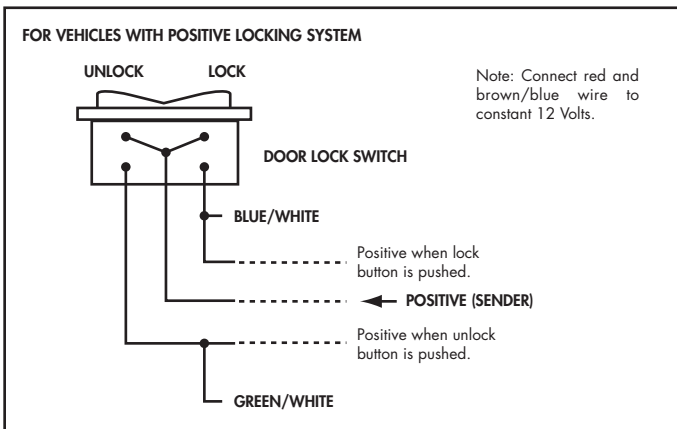

Testing (w/an airbag safe digital volt-ohm meter)

Connect the testlight wire to a 12 volts (+), then probe all wires from your door lock switch to determine the lock, unlock, and sender wires.

1. If you come to a wire that LOCKS your doors when probed (+), then you have found the lock wire. Connect the BLUE/WHITE wire from the keyless entry unit to this wire.
2. If you come to a wire that UNLOCKS your doors when probed (+), then you have found the unlock wire. Connect the GREEN/WHITE wire from the keyless entry unit to this wire.
3. From the keyless entry unit connect the BROWN/BLUE wire to your sender wire. This wire will be a constant "+".
4. Install the fuse on the red wire then connect the RED wire to a constant 12 volts (+), and the BLACK wire to a body ground.

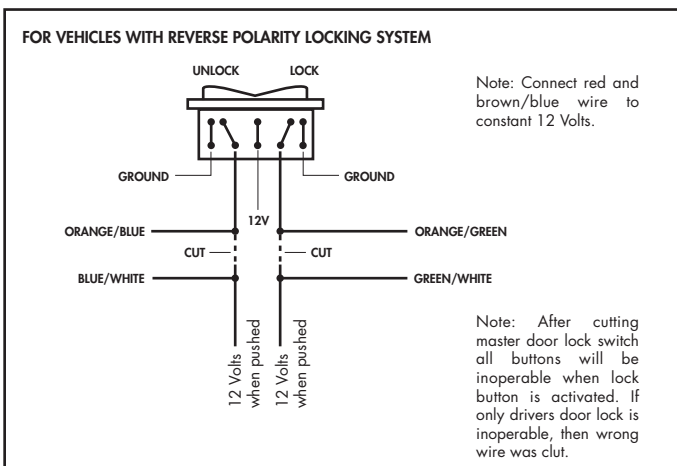

Similar to positive trigger, but will have 5 wires. 2 wires will be grounded, another 2 wires will be positive triggers, and 1 will have a constant 12 volts (sender wire).

1. Install the fuse on the red wire then connect the BROWN/BLUE, & RED wires to 12 volts.
2. From the keyless entry unit connect the BLACK wire to metal ground.
3. Cut the drivers door lock wire. This wire will have 12 volts when lock button is pushed.
4. Connect the ORANGE/BLUE wire to the switch's side of the lock wire.
5. Connect the BLUE/WHITE wire to the motor's side of the lock wire.
6. Cut the drivers unlock wire. This wire will have 12 volts when unlock button is pushed.
7. Connect the ORANGE/GREEN wire to the switch's side of the unlock wire.
8. Connect the GREEN/WHITE wire to the motor's side of the unlock wire.

# WIRING DIAGRAMS



## KL550 Polarity:

The BROWN/BLUE wire is used to adjust polarity for this system. The recommended configuration, which also reflects per the wiring diagram provided, is based on a negative trigger system, so this wire must be grounded. If configuring as a positive trigger system, provide a constant 12v source to the BROWN/BLUE wire, all outputs then become positive output triggers.

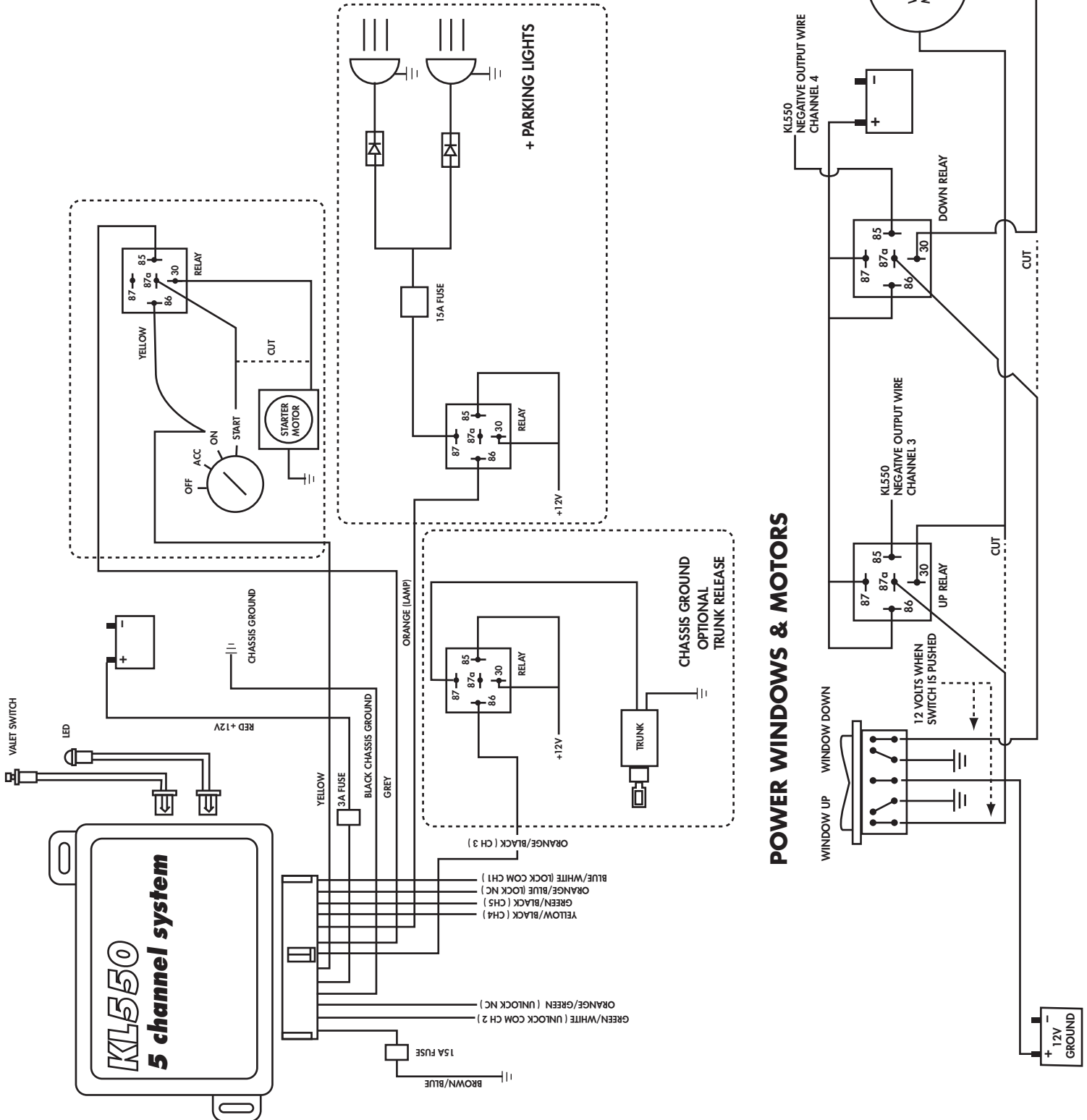

## POWER WINDOWS & MOTORS

